



İçindekiler

Index

Inhaltsverzeichnis



Genel Bilgiler <i>General Info.</i> Einführung	Sembollerin Açıklaması	<i>Key of Symbols</i>	Erklärung der Bezeichnungen	
	Ürün Yelpazesi	<i>Production Range</i>	Produktpalette	04
	M Serisi Redüktörlerin Genel Özellikleri	<i>General Specifications of M Series Gearboxes</i>	Allgemeine Eigenschaften Von M Serie Getrieben	06
	Teknik Tanımlamalar	<i>Technical Explanations</i>	Technische Erläuterungen	07
	Teknik Özellikler	<i>Technical Specifications</i>	Technische Informationen	07
	Aksesuarlar	<i>Accessories</i>	Zubehör	08
	Tip Tanımlaması	<i>Unit Designation</i>	Typenbezeichnungen	10
	Örnek Tip Tanımlamaları	<i>Sample Designations</i>	Typenbezeichnungsbeispiele	13
	Motor Büyüklüğüne Göre Geometrik Çevrim Oranı Komb.	<i>Geomet. Possible Combinations of Ratios According to Motor Size</i>	Geomet. Mögliche Kombi. von Übersetz. nach Motorbaugröße	14
	Servis Faktörü	<i>Service Factor</i>	Betriebsfaktor	16
	Yük Sınıflandırması	<i>Load Classification</i>	Belastungsart	17
	Redüktör Dönüş Yönleri	<i>Direction of Rotation</i>	Getriebedrehrichtungen	19
	Radyal Yükler	<i>Overhung Loads</i>	Querkräfte	20
	Radyal Yüklerin Hesabı	<i>Calculation Of Overhung Loads</i>	Berechnung der Querkräfte	21
	Eşdeğer Güç Hesabı	<i>Equivalent Power Calculation</i>	Äquivalente Leistung	22
	Eşdeğer Güç Hesabı Örneği	<i>Equivalent Power Cal. Example</i>	Beispiel für Äquivalente Leistung	23
	Redüktör Seçimi	<i>Gearbox Selection</i>	Getriebeauswahl	24
	Redüktör Seçim Formu	<i>Gearbox Selection Form</i>	Formular für Getriebeauswahl	26
	Yağlama	<i>Lubrication</i>	Schmierung	30
	Yağ Tipleri	<i>Oil Types</i>	Schmierstoffe	31
	Montaj Pozisyonları	<i>Mounting Positions</i>	Bauformen	32
	Montaj Şekilleri ve Yağ Tapaları	<i>Mounting Pos. and Oil plugs</i>	Bauform. und Ölverschlussschra.	33
	Yağ Miktarları	<i>Oil Quantities</i>	Ölmengen Tabellen	33
	AC Motorlar	<i>AC Motors</i>	Drehstrommotoren:	
Motorlar <i>Motors</i> Motor	a- Genel Özellikler	<i>a- General Spec. of AC Motors</i>	a-Eigensch. des Drehstrommotors	39
	b- Çalışma Türleri	<i>b-Modes of Operation</i>	b-Betriebsarten	40
	c- Koruma Sınıfı	<i>c- Protection Class</i>	c- Schutzarten	41
	d- İzolasyon Sınıfı	<i>d- Insulation Class</i>	d- Isolationsklasse	41
	e- Verim Sınıfları	<i>e- Efficiency Classes</i>	e- Energieeffizienzklassen	41

M0301-0315



İçindekiler

Index

Inhaltsverzeichnis



Frenler <i>Brakes</i> Bremsen	f- AC Frekans İntertörler	<i>f- AC Frequency Inverters</i>	f- AC Frequenz Umrichter	42
	DC Motorlar	<i>DC Motors</i>	DC Motoren	
	a- Genel Özellikler	<i>a- General Specif. of DC Motors</i>	a- Eigenschaften von DC Motoren	43
	b- DC Motorların Çalışma İlkeleri	<i>b- Operating principals of DC Motors</i>	b- Funktionsprinzip der DC Motoren	43
	c- DC Motor Çeşitleri	<i>c- Types of DC Motors</i>	c- Arten von DC Motoren	43
	d- DC Motorlarda Hız Kontr.	<i>d- Speed Control of DC motors</i>	d- Drehzahl Kontrolle DC Motoren	43
	Elektromanyetik Frenler	<i>Electromagnetic Brakes</i>	Elektromagnetische Bremsen	44
	Fren Çeşitleri	<i>Brake Types</i>	Bremsenarten	44
	Fren Bağlantı Şekli	<i>Connection Types</i>	Schaltungsarten	45
	Fren Seçimi	<i>Brake Selection</i>	Bremswahl	46
	Frenin Termik Kapasitesi	<i>The Thermal Capacity of Brake</i>	Therm. Kapazität der Bremsen	47
Güç Devir Tabl. <i>Perform. Tables</i> Leistung- Drehzahl Tabellen.	Motorlu Güç Devir Tabloları	<i>Geared Motors Performance Tables</i>	Getriebeleistung und drehzahl Übersicht	49
	Motorsuz Güç Devir Tabloları	<i>Gear Units Performance Tables</i>	Getriebe Leistung und Drehzahl-übersicht	315
Ölçü Sayfaları <i>Dimension Pages</i> Abmesungs Tabellen	MR, NR serileri	<i>MR, NR series</i>	MR, NR serien	101
	MN, NN serileri	<i>MN, NN series</i>	MN, NN serien	132
	MV, NV serileri	<i>MV, NV series</i>	MV, NV serien	172
	MT, NT serileri	<i>MT, NT series</i>	MT, NT serien	329
	MRF serileri	<i>MRF series</i>	MRF serie	202
	MNF serileri	<i>MNF series</i>	MNF serie	218
	MVF serileri	<i>MVF series</i>	MVF serie	242
	MTF serileri	<i>MTF series</i>	MTF serie	360
	NRB serileri	<i>NRB series</i>	NRB serie	258
	NNB serileri	<i>NNB series</i>	NNB serie	276
	NVB serileri	<i>NVB series</i>	NVB serie	296
	NTB serileri	<i>NTB series</i>	NTB serie	372



Genel Bilgiler

General Information

Einführung



Sembollerin Açıklaması

c_t: Anahtarın devreye girme zamanı katsayısı

f_s: Servis faktörü

F_{ama}: Çıkış milinde müsaade edilen eksenel yükler [kN]

F_{ame}: Giriş milinde müsaade edilen eksenel yükler [kN]

F_{qam}: Çıkış milinde izin verilen radyal yöndeki yükler [N]

F_{qem}: Giriş milinde izin verilen radyal yöndeki yükler [N]

F_{qa}: Çıkış miline gelen radyal yöndeki yükler [N]

F_{qe}: Giriş miline gelen radyal yöndeki yükler [N]

F_q: Radyal yöndeki yükler [N]

F_a: Eksenel yöndeki yükler [N]

i: Tahvil oranı

J_{ext}: Motor miline indirgenmiş toplam dış atalet momenti [kgm²]

M_2: Çıkış momenti [Nm]

M_a: Anma momenti [Nm]

n_1: Redüktör giriş mili devri [d/dak]

n_2: Redüktör çıkış mili devri [d/dak]

P_{eq}: Eşdeğer güç [kW]

P_e: Nominal güç (Bak. Güç-Devir Tabloları) [kW]

P_M: Tahrik edilecek makina için gerekli güç (Değişken yükler için eşdeğer güç alınır) [kW]

t: Zaman [s]

T_e: Eşdeğer moment [Nm]

Key of Symbols

c_t: Coefficient of switch on time.

f_s: Service factor

F_{ama}: Permissible axial loads which can be applied to output shafts [kN]

F_{ame}: Permissible axial loads which can be applied to input shafts [kN]

F_{qam}: Permissible overhung loads which can be applied to output shafts [N]

F_{qem}: Permissible overhung loads which can be applied to input shafts [N]

F_{qa}: Overhung loads applied to the output shaft [N]

F_{qe}: Overhung loads applied to the input shafts [N]

F_q: Overhung loads on output shaft [N]

F_a: Axial loads on output shaft [N]

i: Transmission ratio

J_{ext}: The total inertia of rotating parts at outside reduced at the motor shaft [kgm²]

M_2: Output torque [Nm]

M_a: Nominal torque [Nm]

n_1: Input speed of gearbox [rpm]

n_2: Output speed of gearbox [rpm]

P_{eq}: Equivalent power [kW]

P_e: Nominal power (given on performance tables) [kW]

P_M: Power consumption of the driven machine (for alternating power, refer to equivalent power) [kW]

t: Time [s]

T_e: Equivalent torque [Nm]

Erklärung der Bezeichnungen

c_t: Koeffizient der Tätigkeitszeit von Schalter

f_s: Betriebsfaktor

F_{ama}: Zulässige Axialkräfte auf Abtriebswelle [kN]

F_{ame}: Zulässige Axialkräfte auf Antriebswelle [kN]

F_{qam}: Zulässige Querkräfte auf Abtriebswelle [N]

F_{qem}: Zulässige Querkräfte auf Antriebswelle [N]

F_{qa}: Querkräfte auf Abtriebswelle [N]

F_{qe}: Querkräfte auf Antriebswelle [N]

F_q: Querkräfte auf Abtriebswelle [N]

F_a: Querkräfte auf Antriebswelle [N]

i: Übersetzungsverhältnis

J_{ext}: Die Gesamtträgheit der rotierende Teile von der Ausgangsseite reduziert auf Motorwelle [kgm²]

M_2: Ausgangsdrehmoment [Nm]

M_a: Nenndrehmoment [Nm]

n_1: Antriebsdrehzahl [U/min]

n_2: Abtriebsdrehzahl [U/min]

P_{eq}: Äquivalente Leistung [kW]

P_e: Getriebe Nennleistung (siehe Leistung- Drehzahl tabellen) [kW]

P_M: Leistung benötigt an der Abtriebswelle (Zur Berechnung bei variablen Leistungen äquivalente Leistung benutzen) [kW]

t: Zeit [s]

T_e: Minimales Drehmoment [Nm]



Genel Bilgiler

General Information

Einführung



Ürün Yelpazesi

Elinizdeki katalog sadece **M ve N serisi** ürünleri içermektedir.

- M ve N Serisi

Helisel alın dişliye sahip, giriş ve çıkış milleri aynı düzlem üzerinde ve birbirine paralel uzanan, üzerlerinde bulunan ayak veya flanş ile makina-ya sabitlenen redüktörlerdir. Dolu mil çıkışlıdır.

- D Serisi

Helisel alın dişliye sahip, giriş ve çıkış milleri aynı düzlem üzerinde, birbirine paralel ve belirli bir aralıkta yerleştirilmiş, iki yan yüzde bulunan bağlantı civataları, flanş veya tork kolu ile makina-ya sabitlenen redüktörlerdir. Delik milli veya mil çıkışlı olabilir.

- E Serisi

Sonsuz vida ve çark dişlili, belirli bir aralıkta ve birbirine dik konumlandırılmış giriş ve çıkış millerine sahip, çepçevre konumlandırılmış ayak bağlantıları, flanş veya tork kolu ile makina-ya sabitlenen redüktörlerdir. Delik milli veya mil çıkışlı olabilir.

- Y Serisi

Yatık tip redüktörler, ağır şartlarda çalışmak üzere dizayn edilmiş redüktör tipleridir. Bu tiplerde redüktör ile bunu tahrik eden mekanizma arasında değişik bağlantı şekilleri mevcuttur (Mekanik ve hidrolik kaplinler, çeşitli tip kayışlar ve zincirle tahrik gibi). Delik milli veya mil çıkışlı olabilir.

- K Serisi

Helisel alın dişli ve konik dişlilerden oluşan, birbirine dik ve belirli bir aralıkta konumlandırılmış giriş ve çıkış milline sahip, çepçevre sunulan ayaklar, flanş veya tork kolu ile makina-ya sabitlenen redüktörlerdir. E serisinden farklı olarak yüksek verime sahiptirler. Delik milli veya mil çıkışlı olabilir.

- H ve B Serisi

Helisel ve/veya konik dişliye sahip ağır hizmet tipi redüktörlerdir. Giriş ve çıkış milleri birbirine paralel veya dik olabilir. Her yönden bağlantı için ayak bağlantıları bulunur. Opsiyonel olarak flanş ile de bağlanabilir. Delik milli veya mil çıkışlı olabilir.

- T Serisi

T Serisi redüktörler helisel dişli iki kademe motorsuz delik milli redüktörlerdir. T Serisi redüktörler delik milli olması ve kompakt gövde yapısı sayesinde daha küçük hacimli alanlara montajı yapılabilmektedir.

- P ve R Serisi

P ve R Serisi redüktörler planet dişli redüktörlerdir. Endüstriyel ve mobil uygulamalarda kullanılırlar. Diğer redüktör tiplerine göre daha küçük hacimde daha büyük tork iletebilirler.

- VR Serisi

VR vinç redüktörleri M1 - M8 (1Dm - 5m) yük sınıflarına uygun olarak, çift veya sabit devirli frenli motorlarla üretilebilmektedir.

Production Range

*This catalogue is containing **M and N series** of gearboxes only.*

- M and N Series

M and N series of YILMAZ REDÜKTÖR are helical geared. The input and output shafts are parallel to each other and on the same plane. The gearbox can be connected to the machine by using the foot or flange on the gearbox. Has solid output shaft.

- D Series

D series are helical geared gearboxes with parallel input and output shafts. The shafts have a distance in between and located on the same plane. The gearbox can be assembled to the machine by using, the connection screws on the sides, flange or torque arm on the gearbox. Can have hollow or solid output shaft.

- E Series

E series gearboxes are with worm and worm-wheel. The input and output shafts are perpendicular to each other and have a distance in between. It can be assembled to the driven machine by the use of the foot, flange or torque arm on the gearbox. Can have hollow or solid output shaft.

- Y Series

Horizontal type gearboxes are designed to operate in heavy conditions. In these types there are a lot of combination forms between gearbox and driver (for example, mechanic and hydraulic couplings, various belt and chain drives etc.). Can have hollow or solid output shaft.

- K Series

These are gearboxes with helical and bevel gears. The input and output shafts are perpendicular to each other and have a distance in between. It can be assembled to the driven machine using the foot, flange or torque arm on the gearbox. They have high efficiency compared to E series. Can have hollow or solid output shaft.

- H and B Series

These gearboxes are helical or/and bevel geared industrial gearboxes. The input and output shafts can be arranged parallel or perpendicular to each other. The gearbox can be assembled by the use of the foot connections on each side. Flange connections are optional. Can have hollow or solid output shaft.

- T Series

T Series are gear units which are helical geared, two staged, hollow shaft mounted gear units and manufactured according to monoblock principal. T Series gearboxes have hollow shaft and compact housing so that T series can be mounted on smaller places.

- P and R Series

P and R Series gearboxes are planetary gearboxes. They are mostly used by industrial and mobile applications. Planetary gearboxes can transfer high torques in small volumes compared to other gearboxes.

- VR Serie

VR hoist drives are produced according to M1 - M8 (1Dm - 5m) load classification.

Produktpalette

Dieses Katalog umfasst nur die **M und N Serie** Getriebe.

- M und N Serie

Diese Modelle sind Stirnradgetriebe mit parallelen Antriebs- und Abtriebswelle auf einer Ebene. Die Getriebe werden mit Fuß- oder Flanschverbindung an die angetriebene Maschine angekoppelt. Hat Vollwelle am Ausgang.

- D Serie

Diese Getriebe sind Stirnradgetriebe mit paralleler Antriebs- und Abtriebswelle, die auf einer Ebene liegen und einen Abstand zueinander haben. Diese Getriebe wird seitlich mit Gewindelöchern am Maschine oder mit einer Flansch verbindet. Kann Voll- und Hohlwelle am Ausgang haben.

- E Serie

Diese Getriebe bestehen aus Schnecke und Schneckenrad. Die Antriebs- und Abtriebswellen sind senkrecht zueinander und haben einen bestimmten Abstand. Das Getriebe wird mit Fußbefestigung, Flanschverbindung oder mit Drehmomentstütze an die angetriebene Maschine montiert. Kann Voll- und Hohlwelle am Ausgang haben.

- Y Serie

Diese Getrieben sind für Einsatz unter schweren Bedingungen ausgelegt. Bei dieser Ausführung gibt es sehr viele verschiedene Verbindungsmöglichkeiten zwischen Antrieb und Getriebe (Zum Beispiel; mechanische und hydraulische Kupplungen, Riementrieb, Kettentrieb usw.). Kann Voll- und Hohlwelle am Ausgang haben.

- K Serie

Diese Getrieben bestehen aus Stirnräder und Kegelhäder. Die Antrieb und Abtriebswellen sind senkrecht und haben einen Abstand zueinander. Das Getriebe wird mit Fußbefestigung, Flanschverbindung oder Drehmomentstütze an die angetriebene Maschine montiert. Der Wirkungsgrad ist wesentlich höher als E Serie. Kann Voll- und Hohlwelle am Ausgang haben.

- H und B Serie

Diese Getriebe sind geeignet für industrielle Anwendungen und haben parallelen oder senkrechten Antrieb und Abtriebswelle auf einer Ebene. Das Getriebe kann mit Füßen, die auf jede Seite der Getriebe vorhanden sind, oder optional mit Flansch an die angetriebene Maschine montiert werden. Kann Voll- und Hohlwelle am Ausgang haben.

- T Serie

TSerien Getriebe sind zwei stufige, schrägverzahnte Hohlwellenflachgetriebe in Monoblockgehäuse. Die T Serie hat eine kompakte Gehäuse und ist serienmäßig mit Abgangshohlwelle hergestellt, so dass das Getriebe minimalen Platzbedarf hat.

- P und R Serie

P und R Serie sind Planetengetriebe, die vielseitig im Industrie und bei mobiler Anwendungen einsetzbar sind, mit Planetenzahnräder. Planetengetriebe können im Vergleich zu anderen Getrieben größere Drehmomente bei kleineren Bauvolumen übertragen.

- VR Serie

VR Krane und Hebezeuge werden geeignet zur Belastungsart M1 - M8 (1Dm - 5m) hergestellt.



Genel Bilgiler

General Information

Einführung



M ...

13 farklı büyüklükte;
Moment aralığı: 50 - 18.000 Nm
Devir aralığı: 0,1 - 500 d/dak
13 different sizes:
Torque range: 50 - 18.000 Nm
Speed range: 0,1 - 500 rpm
13 verschiedene Baugrößen:
Drehmomentbereich: 50 - 18.000 Nm
Drehzahlbereich : 0,1 - 500 U/min



N ...

13 farklı büyüklükte;
Moment aralığı: 50 - 18.000 Nm
Devir aralığı: 0,1 - 500 d/dak
13 different sizes:
Torque range: 50 - 18.000 Nm
Speed range: 0,1 - 500 rpm
13 verschiedene Baugrößen:
Drehmomentbereich: 50 - 18.000 Nm
Drehzahlbereich : 0,1 - 500 U/min



E ...

8 farklı büyüklükte;
Moment aralığı: 5 - 1.000 Nm
Devir aralığı: 0,1 - 400 d/dak
8 different sizes:
Torque range: 5 - 1.000 Nm
Speed range: 0,1 - 400 rpm
8 verschiedene Baugrößen:
Drehmomentbereich: 5-1.000 Nm
Drehzahlbereich : 0,1-400 U/min



K ...

7 farklı büyüklükte;
Moment aralığı: 200 - 15.000 Nm
Devir aralığı: 0,1 - 400 d/dak
7 different sizes:
Torque range: 200 - 15.000 Nm
Speed range: 0,1 - 400 rpm
7 verschiedene Baugrößen:
Drehmomentbereich: 200 - 15.000 Nm
Drehzahlbereich : 0,1 - 400 U/min



D ...

10 farklı büyüklükte;
Moment aralığı: 130 - 18.000 Nm
Devir aralığı: 0,1 - 350 d/dak
10 different sizes:
Torque range: 130 - 18.000 Nm
Speed range: 0,1 - 350 rpm
10 verschiedene Baugrößen:
Drehmomentbereich: 130 - 18.000 Nm
Drehzahlbereich : 0,1 - 350 U/min



Y ...

25 farklı büyüklükte;
Moment aralığı: 1200 - 43000 Nm
Devir aralığı: 2,6 - 990 d/dak
25 different sizes:
Torque range: 1200 - 43000 Nm
Speed range: 2,6 - 990 rpm
25 verschiedene Baugrößen:
Drehmomentber. :1200-43000 Nm
Drehzahlbereich : 2,6-990 U/min



H ...

13 farklı büyüklükte;
Moment aralığı: 2.500 - 150.000 Nm
Devir aralığı: 0,1 - 250 d/dak
13 different sizes:
Torque range: 2.500 - 150.000 Nm
Speed range: 0,1 - 250 rpm
13 verschiedene Baugrößen:
Drehmomentber. :2.500 - 150.000 Nm
Drehzahlbereich : 0,1 - 250 U/min



B ...

13 farklı büyüklükte;
Moment aralığı: 5.000 - 150.000 Nm
Devir aralığı: 0,1 - 115 d/dak
13 different sizes:
Torque range: 5.000 - 150.000 Nm
Speed range: 0,1 - 115 rpm
13 verschiedene Baugrößen:
Drehmomentber. :5.000-150.000 Nm
Drehzahlbereich : 0,1-115 U/min



P ...

10 farklı büyüklükte;
Moment aralığı: 1.000 - 50.000 Nm
Tahvil oranları: 3,5 - 3000 arası
10 different sizes:
Torque range: 1.000 - 50.000 Nm
Transmission ratio: 3,5 - 3000
10 verschiedene Baugrößen:
Drehmomentber. : 1.000 - 50.000 Nm
Übersetzung: 3,5 - 3000



R ...

10 farklı büyüklükte;
Moment aralığı: 1.000 - 50.000 Nm
Tahvil oranları: 3,5 - 3000 arası
10 different sizes:
Torque range: 1.000 - 50.000 Nm
Transmission ratio: 3,5 - 3000
10 verschiedene Baugrößen:
Drehmomentber. : 1.000 - 50.000 Nm
Übersetzung: 3,5 - 3000



T ...

10 farklı büyüklükte;
Moment aralığı: 200 - 18.000 Nm
Devir aralığı: 46 - 280 d/dak
10 different sizes:
Torque range: 200-18.000 Nm
Speed range: 46-280 rpm
10 verschiedene Baugrößen:
Drehmomentber. :200-18.000 Nm
Drehzahlbereich : 46-280 U/min



VR ...

VR vinç redüktörleri
M1 - M8 ,(1Dm - 5m) yük sınıfı
ISO 4301 / 1 ,(FEM 1.001 / III)
VR Hoist Drive Units
M1 - M8 ,(1Dm - 5m) load classification
ISO 4301 / 1 ,(FEM 1.001 / III)
VR Kran und Hebezeug Getriebe
M1 - M8 ,(1Dm - 5m) Belastungsart
ISO 4301 / 1 ,(FEM 1.001 / III)



Genel Bilgiler

General Information

Einführung



M Serisi Redüktörlerin Genel Özellikleri

YILMAZ REDÜKTÖR M serisi redüktörlerini rijitlik, sızdırmazlık, ses ve dişli mukavemetlerinde büyük avantajlar sağlayan bir prensip olan tekil gövde (monoblok) prensibine göre geliştirmiştir. Redüktörler içinde yataklamalar herhangi bir kapak veya gövdeye birleşimi olan parça üzerinde değil, direkt olarak gövdenin kendi üzerinde kalmaktadır. Gövde eksenlerinin tek operasyonda işlenmesi, yüksek imalat hassasiyeti sağlamaktadır. Yüksek teknolojiyle dişli toleranslarında elde ettiğimiz yüksek kalitelere GG20-22 malzemenin olan gövde cevap vermektedir. Bu prensip aynı zamanda rulman ve dişli ömürlerinde bir artış sağlamakta olup; yüksek radyal yükler taşınabilmektedir. Redüktör içinde kullanılan rulman, dişli ve mil hesaplamaları güncel standartlara dayanan profesyonel yazılımlar ile yapılmaktadır. Redüktör gövdesindeki ara perde gövde ana gövdeyle bir bütündür. Ara perde, dişlilerin her iki taraftan, dişliye en yakın noktadan yataklanmasını sağlar. Böylelikle millerin sehim ve salgılarının minimum düzeye inmesini sağlayarak sessiz redüktörlerin üretiminde rol oynamaktadır.

M serisi redüktörler kolay montaj ve esnek kullanım olanağına sahiptir. Redüktörlerin motor bağlantısı müşteri isteğine bağlı olarak standart akuple, IEC B5 veya B14'e uygun olabilir. Tüm modeller ayaklı veya flanşlı olarak, tek gövde içinde iki veya üç kademeli olarak sunulmaktadır. Redüktörler aynı güç ve devir değerleri için daha kompakt hale ve daha düşük eksen mil yüksekliklerine getirilmiştir. Tüm redüktörler modüler sistemde düşünülmüş olup, çiftli redüktörlerde ara bağlantılardaki değişiklikler minimum seviyeye indirilmiştir. Tüm toleranslar kalite güvence sistemi ile aktif kontrol altındadır.

YILMAZ REDÜKTÖR olarak tasarım prensibimiz;

- Yüksek teknoloji kullanmak
- Güvenilirlik,
- Yüksek güç yoğunluğu,
- Yüksek verim,
- Montaj uyumluluğu,
- Esnek çözümler

Dikkat Edilecek Hususlar !

- Bu katalogta verilen resimler görsel amaçlıdır ve şekilsel detaylar bağlayıcı değildir.
- YILMAZ REDÜKTÖR, ürünler ve kataloglar üzerinde, müşterileri bilgilendirmeksizin her türlü değişikliği yapma hakkına sahiptir.
- Ürünler teslim alındıktan sonra ürünle birlikte verilen kullanım kılavuzu okunmadan sistem devreye alınmamalıdır.
- Katalogta verilen yağ miktarları referans amaçlıdır. Gerçek yağ seviyesi için redüktör üzerinde bulunan yağ seviye tapası kullanılmalıdır. Yağ viskozitesi için, redüktör etiketine bakınız.
- Sipariş anında montaj pozisyonu bildirilmeyen M serisi redüktörler **M1**, N serisi redüktörler **M4** montaj pozisyonuna uygun sevk edilir. Etiketle yazan montaj pozisyonundan farklı bağlanan redüktörler garanti kapsamından çıkar. Bu katalogta verilen redüktör ağırlıkları ortalama ağırlık değerleridir. Tahvil oranına ve üzerinde bağlı olan aksesuara göre ağırlıklar farklılık gösterebilir.

General Specifications of M Series Gearboxes

YILMAZ REDÜKTÖR M series gearboxes has been developed according to the one part housing principle (monoblock) which has advantages in rigidity, oil leakage, noise level and gear strength. All bearings are supported by one part housing itself and not by cover plates or other parts which connects some other parts. Machining axes with one operation cycle gives high precision and very tight tolerances to axes. With high manufacturing technologies achieved high gear qualities have response with housing from GG20-22 material. This design ensures high bearing and gear lifetime at the mean time; high overhung loads can be taken. Calculations of bearings, gears and shafts used in the gearbox has been made with professional software, which are implemented according to up-to-date standards. The middle bearing support plate makes it possible to have optimum support for bearings used in three stage gearboxes. So run out and deformation by running on load is minimized which makes low noise gearbox production possible.

M series gearboxes have the ability of easy mounting and flexible usage. Motor connection of gearboxes can be offered according to customers request suitable to direct, IEC B5 or B14 connection. All models can be delivered foot or flange mounted with two or three stages in one housing. Gearboxes have lower axis height than the old models and compact for the same power and speed. All gearboxes has been designed modular so double gearboxes can be coupled with minimum change. Each tolerances on every part used in gearbox are actively controlled by our quality assurance system.

As we are YILMAZ REDÜKTÖR,our design principals are;

- Using high technology
- Reliability
- High power density
- High efficiency
- Mounting compatible
- Flexible solutions

Attention to the following points !

- Drawings are examples only and the details on the drawings or illustrations are not strictly binding.
- YILMAZ REDÜKTÖR reserve the right to make all kinds of changes in products and catalogues without any notice.
- Prior to commissioning, the operating instructions provided with the gearbox must be observed.
- Oil quantities given are guide values only. The exact quantity of oil should be checked by using the provided oil level plugs according mounting positions. For correct oil viscosity refer to the nameplate.
- If the mounting position is not informed upon ordering, the M series gear units are delivered according to **M1** and N series gear units are delivered according to **M4** mounting position. A different operation then the indicated mounting position on the name plate cancels the warranty. The weights given in this catalogue are mean values. Depending on the ratio and accessories the weights can differ.

Allgemeine Eigenschaften von M Serie Getrieben

YILMAZ REDÜKTÖR M Serie-Getriebe wurde nach dem Prinzip Blockgehäuse, welche Vor- teile beim Steifigkeit, Dichtheit, Geräusch und Zahnradfestigkeit hervorbringt, entwickelt. Alle Lagerungen sitzen auf nicht geteilte Oberfläche des Gehäuses, wo es keine Verbindung für Deckel oder ein anderes Teil gibt. Alle Achsen werden mit einer Aufspannung bearbeitet. Dieses Vorgehen erlaubt höchste Genauigkeit bei Achsentoleranzen. Mit hohen Fertigungstechnologien erreichte hohe Zahnqualitäten werden mit Gehäuse aus GG20-22 ergänzt. Diese Konstruktion sorgt für hohe Lager- und Zahnlebensdauer; so können hohe Querkräfte getragen werden. Berechnungen von Lagern, Getrieben und Wellen im Getriebe werden mit professioneller Software, die gemäß aktuellen Standards implementiert sind, durchgeführt. Die mittlere Trägerplatte ermöglicht eine optimale Unterstützung für Lager welches in der drei stufige Getriebe eingesetzt wird. So werden Rundlauffehler und Verformung unter Last minimiert, was Produktion von geräuscharmen Getrieben möglich macht.

M Serie-Getriebe sind leicht montierbar und einsetzbar. Motoranschluss von Getrieben kann nach Kundenwunsch geeignet zu direkte, IEC B5 oder B14-Verbindung angeboten werden. Alle Modelle können mit Fuß oder Flansch in zwei oder drei stufige Getriebegehäusen geliefert werden. Diese Getriebe haben niedrige Achsenhöhe als alte Modelle und sind kompakter für die gleiche Leistung und Geschwindigkeit. Alle Getriebe wurde modular konzipiert, sodass Doppel-Getriebe mit wenigem Aufwand gekoppelt werden kann. Jede Toleranzen auf jedem Teil in Getriebe werden aktiv durch Qualitätssicherungssystem überprüft.

Als YILMAZ REDÜKTÖR unsere Entwurfsprinzipien sind;

- Verwenden von hohen Fertigungstechniken
- Hohe Betriebssicherheit
- Leistungsdichte
- Hoher Wirkungsgrad
- Universale Montagemöglichkeit
- Sonderlösungen

Bitte folgende Punkte beachten !

- Die Abbildungen sind beispielhaft und nicht verbindlich.
- Alle Änderungen auf dem Katalog und an der Produkte bleiben vorbehalten und können ohne Kenntnisnahme erfolgen.
- Vor Inbetriebnahme ist die mit gelieferter Betriebsanleitung zu beachten.
- Angaben über Ölmengen sind unverbindlich. Maßgebend ist die Ölstandsschraube in der geeigneten Montageposition. Ölviskosität und Sorte muss den Angaben des Typenschildes entsprechen.
- Wenn die Bauform bei der Bestellung nicht angegeben ist, erfolgt die Lieferung in der Bauform **M1** für M Serie und **M4** für N Serie. Wenn die Getriebe anders als auf dem Namenschild benannte Bauform eingesetzt werden, verliert die Garantie ihre Gültigkeit. Die angegebenen Gewichte sind unverbindliche Mittelwerte ohne Zubehör; genauere Gewichte sind abhängig von Zubehör und Übersetzung.



Genel Bilgiler

General Information

Einführung



Teknik Tanımlamalar

- Çıkış Momenti (M_2): [Nm]

Motorun verdiği momentin tahvil oranı ve verimle ile çarpılarak elde edilen değerdir. Redüktörün çıkışından alınabilecek moment gösterir.

- Anma Momenti (M_a): [Nm]

Redüktörün $f_s=1$ şartı için mekanik olarak taşıdığı moment değeridir.

- Nominal Güç (P_n): [kW]

Nominal güç, redüktörün $f_s=1$ şartı için mekanik olarak taşıyabileceği güç değeridir. Redüktörlerin nominal güçleri, güç devir tablolarında verilmiştir.

- Çevrim oranı (i):

Redüktörün giriş devrinin çıkış devrine oranıdır. Yılmaz Redüktör M serisi redüktörlerde 3,5-23500 arasında değişen çevrim oranları mevcuttur.

- Eşdeğer Güç ve Moment

P_{eq} [kW], T_e [Nm]

Sabit devir altında ancak değişken yük değerlerinde çalışan redüktörlerde, sabit yük altında çalışma şartlarına eşdeğer gelen moment ve güç değerleridir. Hesaplama yöntemi sayfa 23'de verilmiştir.

- İhtiyaç güç (P_M): [kW]

Redüktörlerin kullanılacağı uygulamanın istenilen şekilde çalışabilmesi için ihtiyaç duyduğu güç değeridir.

- İhtiyaç moment (T): [Nm]

Redüktörün kullanılacağı uygulamanın çalışabilmesi için ihtiyaç duyduğu moment değeridir. Seçilen redüktör için her zaman çıkış momentini eşit yada daha düşük olmalıdır.

- Müsade Edilen Eksenel ve Radyal Yükler

Fqem, Fqam: [N]

Redüktörün giriş veya çıkış milinde müsade edilen eksenel ve radyal yüklerdir.

- Servis Faktörü (f_s):

Redüktörün çalıştığı şartlar ile uyumlu olması için gerekli olan emniyet katsayısıdır. $f_s=1$, düzgün ve sakin yüklerde, günlük sekiz saat, saatte 100 dur-kalk çalışmayı karşılar. Detaylar için redüktör seçim bölümüne bakınız.

Teknik Özellikler:

- Ses seviyesi:

Redüktörlerimizin ses seviyesi VDI 2159' da verilen redüktörler için müsade edilen ses seviyelerinin altındadır.

- Boya ve Korozyon Koruması:

Redüktörlerin standart rengi DIN1843'e göre RAL 7031 dir. İstek üzerine farklı renklerde boyanabilir. Nemli ve korozif bölgeler için istek üzerine farklı boya uygulanabilir.

Technical Explanations

- Output Torque (M_2): [Nm]

Multiplication of motor output torque with transmission ratio and efficiency gives the result of output torque at the output shaft of the gear unit.

- Nominal Torque (M_a): [Nm]

Nominal torque is the mechanical torque which the gearbox can resist under $f_s=1$ conditions.

- Nominal Power (P_n): [kW]

The nominal power is the power which gearbox can mechanically resist under $f_s=1$ condition. The nominal powers are given on the performance tables.

- Ratio (i):

Ratio between output shaft speed and input shaft speed. Available ratios of Yilmaz Redüktör M series are between 3,5 to 23500.

- Equivalent Power and Torque

P_{eq} : [kW], T_e [Nm]

For gearbox unit with constant speed but variable working conditions: This is the calculated power or torque which is equivalent to the values at working under constant working conditions.

- Required Power (P_M): [kW]

Required power for the applications which is able to drive the system.

- Required Torque (T): [Nm]

Required torque for applications. Required torque always must be equal or smaller than output torque for selected gearbox.

- Permissible Axial and Overhung Loads:

Fqem, Fqam [N]

Permissible axial and overhung load at the output or input shaft of gearboxes.

- Service Factor (f_s):

Service factor is a safety coefficient, which takes into account the different running conditions of the driven machine. $f_s=1$ is used for uniform loads 8 hours working per day and up to 100 cycle per hour.

Technical Specifications:

- Noise Level:

The noise level of our gearboxes is below the permitted values defined in VDI guidelines 2159 for gear units.

- Coating and Corrosion Protection:

The gearboxes are painted with RAL 7031 according DIN1843. Different colors are available upon request. Paintings for high humidity or chemically aggressive environments are available upon request.

Technische Erläuterungen

- Ausgangsmoment (M_2): [Nm]

Multiplikation von Ausgangsmoment des Motors mit Übersetzungsgrad und Division das Ergebnis mit Wirkungsgrad ergibt den Betrag von Ausgangsmoment der Getriebe.

- Nennmoment (M_a): [Nm]

Mechanisches Belastungsmoment der Getriebe unter dem Bedingung $f_s=1$.

- Nennleistung (P_n): [kW]

Die Nennleistung ist die mechanische Grenzfestigkeitsleistung für $f_s=1$. Kann von der Leistung-Drehzahltable abgelesen werden.

- Übersetzung (i):

Wird aus dem Verhältnis von Ausgang- zu Eingangswinkelgeschwindigkeit bestimmt. Gängige Übersetzungen von Yilmaz M Serie Getriebe liegt zwischen 3,5 bis 23500.

- Äquivalente Leistung und Moment

P_{eq} : [kW], T_e [Nm]

Für mit konstanten Drehzahl aber unter veränderlichen Betriebsbedingungen arbeitende Getriebe berechnete Leistung und Moment äquivalent zu Werten beim Arbeiten unter konstanten Betriebsbedingungen.

- Notwendige Leistung (P_M): [kW]

Für das Getriebe notwendige Leistung, um Arbeiten von Getriebe bei der für das Getriebe gedachten Anwendung zu gewährleisten.

- Notwendige Moment (T): [Nm]

Notwendige Moment für Anwendungen. Für den ausgewählte Getriebe soll das notwendige Moment gleich dem Ausgangsmoment oder kleiner als diesem Moment sein.

- Zulässige Axial- oder Querkräfte:

Fqem, Fqam [N]

Bei der Anwendungen während der Betrieb zulässige axiale oder radiale Eingangs- oder Ausgangsbelastungen.

- Betriebsfaktor (f_s):

Dieser Faktor f_s ist ein Sicherheitsfaktor, damit die Getriebe unter verschiedenen Bedingungen mit genügender Sicherheit arbeitet. $f_s=1$ gilt für gleichförmig Belastung, mit 8 Betriebsstunden pro Tag und bis zum 100 Schaltungen pro Stunde.

Technische Informationen:

- Geräuschpegel:

Geräuschstärken aller Getriebe bleiben unter die zulässigen Werte, die für die Getriebe in der VDI-Richtlinie 2159 festgelegt sind.

- Lackierung und Korrosionsschutz:

Die Getriebe werden mit der Farbe RAL 7031 nach DIN1843 lackiert. Auf Wunsch sind Sonderlackierungen möglich. Alle Getriebe können auf Wunsch auch in korrosionsgeschützter Ausführung für aggressive Umgebungen geliefert werden.



Genel Bilgiler General Information Einführung



- Yağlama:

M ve N Serisi redüktörler yağlama tablolarında verilen yağlar ile doldurulmaktadır. Yağ detayları için yağlama bölümüne bakınız.

- Aksesuarlar:

M ve N Serisi redüktörlerde aşağıdaki aksesuarlar kullanılabilir.

- IEC B5/B14 Motor bağlantı flanşları
- Çıkış Bağlantı Flanşları
- Geri dönüş kilidi
- Özel keçe çözümleri,
- Şeffaf yağ seviye göstergesi
- Elektromanyetik frenler

Diğer özel aksesuarlar için lütfen, YILMAZ REDÜKTÖR ile temasa geçiniz.

- Lubrication:

M and N series of gearboxes are filled with oils which is indicated on lubrication tables. For lubrication details please refer to the lubrication section.

- Accessories:

The following accessories can be applied to M and N series gearboxes.

- IEC B5/B14 Motor connection flange
- Output flanges
- Backstops
- Special sealing solutions.
- Transparent oil level indicator,
- Electromagnetic brakes.

For other accessories please contact, YILMAZ REDÜKTÖR.

- Schmierung:

M und N Serien Getriebe werden mit Ölen entsprechend der Schmierungstabellen, falls nicht anders vereinbart, geliefert. Für weitere Schmierungsangaben siehe Kapitel Schmierung.

- Zubehör:

Folgendes Zubehör kann für Getriebe der M und N Serien geliefert werden.

- IEC B5/B14 Motor Adapter,
- Abtriebsflansch,
- Rücklaufsperrn,
- Spezielle Dichtungssysteme,
- Transparente Ölstandsanzeige
- Elektromagnetische Bremsen

Für weiteres Zubehör kontaktieren Sie bitte mit, YILMAZ REDÜKTÖR.

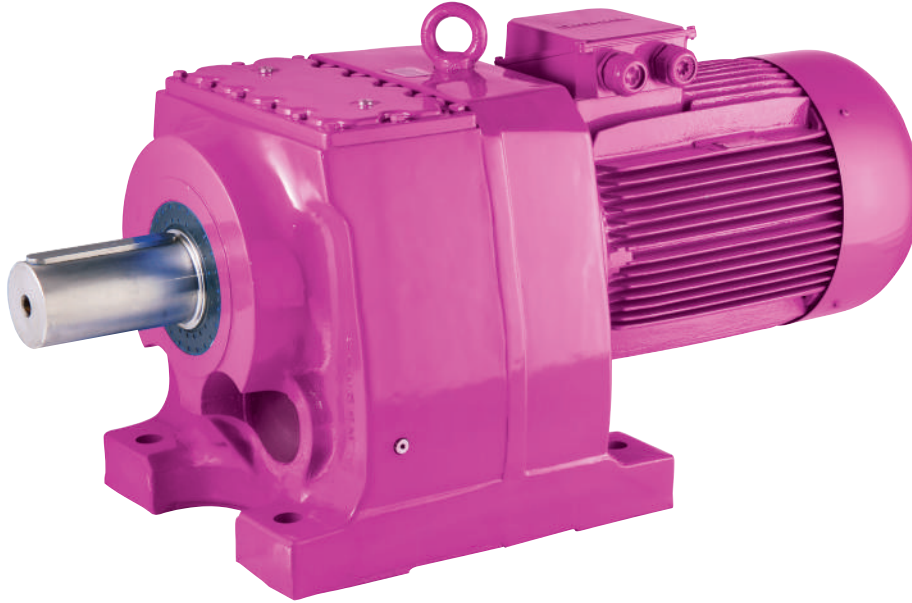



Genel Bilgiler
General Information
Einführung





Genel Bilgiler General Information Einführung



Tip Tanımlaması / Unit Designation / Typenbezeichnungen

M R 4 7 3 - 90S / 4 - L02

Fren / Brake / Bremse

L-220V **Fanlı** / With Fan / Mit Lüfter
P-24V **Fanlı** / With Fan / Mit Lüfter
S-220 V **Fansız** / Without Fan / Ohne Lüfter
Z-24 V **Fansız** / Without Fan / Ohne Lüfter

01-10 Nm **10-100 Nm**
02-25 Nm **20-200 Nm**
04-40 Nm **30-300 Nm**
05-50 Nm **40-400 Nm**

Kutup sayısı / Number of poles / Anzahl der Polen

Motor Büyüklüğü / Motor Size / Motorbaugröße

MR / NR ve MV / NV tipleri için / For MR / NR and MV / NV Types / Für die Typen
MR / NR und MV / NV

MN / NN tipleri için / For MN / NN types / Für die Typen
MN / NN

90S / 4

Kutup Sayısı / Pole Number / Anzahl der Polen

Gövde uzunluğu / Frame Length / Gehäuselänge
des Motors

Motor büyüklüğü / Motor size / Motorbaugröße

A06 :63 B5 **A09** : 90 B5 **A13**:132 B5 **A25**: 250 B5
B06 :63 B14 **B09** : 90 B14 **B13**:132 B14 **A28**: 280 B5
A07 :71 B5 **A10** :100 B5 **A16**:160 B5 **A31**: 315 B5
B07 :71 B14 **B10** :100 B14 **A18**:180 B5
A08 :80 B5 **A11** :112 B5 **A20**:200 B5
B08 :80 B14 **B11** :112 B14 **A22**:225 B5

Kademe Sayısı / Stage / Anzahl der Stufen

2 Kademe / 2 Stages / 2 stufig **5 Kademe / 5 Stages / 5 stufig**
3 Kademe / 3 Stages / 3 stufig **6 Kademe / 6 Stages / 6 stufig**
4 Kademe / 4 Stages / 4 stufig

Revizyon Numarası / Revision Number / Änderungsnummer

Gövde Büyüklük / Housing Size / Größe der Gehäuse

1...9

Giriş Tipi / Input Type / Eingangstyp

R :Motorlu / With Motor / Mit Motor

N :Motorsuz ve IEC B5/B14 Flanş Girişli / IEC B5 / B14 Flanged without Motor / Mit IEC B5/B14 Motorflansch ohne Motor

V :Motorlu ve IEC B5/B14 Flanş Girişli / IEC B5 / B14 Flanged with Motor / Mit Motor und IEC B5/B14 Motorflansch

T :Motorsuz Giriş Milli / With Solid Input Shaft / Eingang ohne Motor

Redüktör Tipi / Gearbox Type / Getriebe

M Serisi / M Serie / M Serie

N Serisi / N Serie / N Serie



Genel Bilgiler

General Information

Einführung



Tip Tanımlaması / Unit Designation / Typenbezeichnungen

MR...	Monoblok tip, helisel redüktörler, motorlu, ayaklı / Monoblock type helical geared motors, foot mounted / Stirradtriebemotoren mit Blockgehäuse, Ausführung mit Fuss
NR...	Monoblok tip, helisel redüktörler, motorlu, flanşlı / Monoblock type helical geared motors, flange mounted / Stirradtriebemotoren mit Blockgehäuse, Ausführung mit Flansch
MN...	Monoblok tip, helisel redüktörler, motorsuz, IEC B5/B14 flanşlı, ayaklı / Monoblock type helical geared units with IEC B5/B14 motor flange, foot mounted / Stirradgetriebe mit Blockgehäuse und IEC B5/B14 Motorflansch, Ausführung mit Fuss
NN...	Monoblok tip, helisel redüktörler, motorsuz, IEC B5/B14 flanşlı, çıkış flanşlı / Monoblock type helical geared units with IEC B5/B14 motor flange, flange mounted / Stirradgetriebe mit Blockgehäuse und IEC B5/B14-Flansch, Ausführung mit Flansch
MV...	Monoblok tip, helisel redüktörler, IEC B5/B14 flanşlı, motorlu, ayaklı / Monoblock type helical geared motors with IEC B5/B14 motor flange, foot mounted / Stirradtriebemotoren mit Blockgehäuse und IEC B5/B14-Flansch, Ausführung mit Fuss
NV...	Monoblok tip, helisel redüktörler, IEC B5/B14 flanşlı, motorlu, flanşlı / Monoblock type helical geared motors with IEC B5/B14 motor flange, flange mounted / Strinradtriebemotoren mit Blockgehäuse und IEC B5/B14, Ausführung mit Flansch
MT...	Monoblok tip, helisel redüktörler, motorsuz, mil girişli, ayaklı / Monoblock type helical geared units with solid input shaft, foot mounted / Stirradgetriebe mit Blockgehäuse und Eingangsvollwelle, Ausführung mit Fuss
NT...	Monoblok tip, helisel redüktörler, motorsuz, mil girişli, flanşlı / Monoblock type helical geared units with solid input shaft, flange mounted / Strinradgetriebe mit Blockgehäuse und Eingangsvollwelle, Ausführung mit Flansch
MRF...	Monoblok tip, helisel redüktörler, ayaklı, çıkış flanşlı, motorlu / <i>Monoblock type helical geared motors, foot mounted, with output flange</i> / Stirradtriebemotoren mit Ausgangsflansch, Ausführung mit Fuss
MNF...	Monoblok tip, helisel redüktörler, ayaklı, çıkış flanşlı, motorsuz, IEC B5/B14 flanşlı / <i>Monoblock type helical geared units, foot mounted, with IEC B5/B14 flange, with output flange</i> / Stirradtriebemotoren mit Ausgangsflansch und IEC B5/B14-Flansch, Ausführung mit Fuss
MVF...	Monoblok tip, helisel redüktörler, ayaklı, çıkış flanşlı, motorlu, IEC B5/B14 flanşlı / <i>Monoblock type helical geared motors, foot mounted, with IEC B5/B14 flange, with output flange</i> / Stirradtriebemotoren mit Ausgangsflansch und IEC B5/B14-Flansch, Ausführung mit Fuss
MTF...	Monoblok tip, helisel redüktörler, ayaklı, çıkış flanşlı, motorsuz, giriş milli / <i>Monoblock type helical geared units, foot mounted, with solid input shaft, with output flange</i> / Stirradgetriebe mit Ausgangsflansch und Eingangsvollwelle, Ausführung mit Fuss.
NRB...	Monoblok tip, helisel redüktörler, agitator boğazlı, motorlu / <i>Monoblock type helical geared motors, with agitator output flange</i> / Stirradtriebemotoren mit Blockgehäuse und Mischerflansch
NNB...	Monoblok tip, helisel redüktörler, agitator boğazlı, motorsuz, IEC B5/B14 flanşlı / <i>Monoblock type helical geared units, with agitator output flange with IEC B5/B14 flange</i> / Stirradgetriebe mit Blockgehäuse, IEC B5/B14- und Mischerflansch
NVB...	Monoblok tip, helisel redüktörler, agitator boğazlı, motorlu, IEC B5/B14 flanşlı / <i>Monoblock type helical geared motors, with agitator output flange with IEC B5/B14 flange</i> / Stirradtriebemotoren mit Blockgehäuse, IEC B5/B14- und Mischerflansch
NTB...	Monoblok tip, helisel redüktörler, agitator boğazlı, motorsuz, mil girişli / <i>Monoblock type helical geared units, with agitator output flange, with solid input shaft</i> / Stirradgetriebe mit Blockgehäuse, Eingangsvollwelle und Mischerflansch



Genel Bilgiler

General Information

Einführung

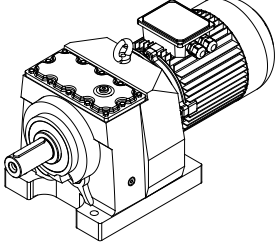
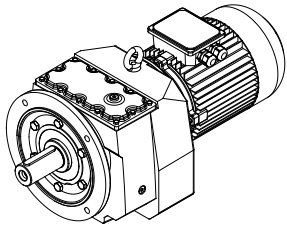
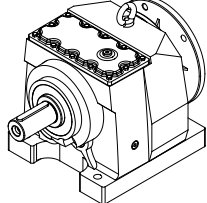
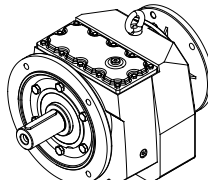
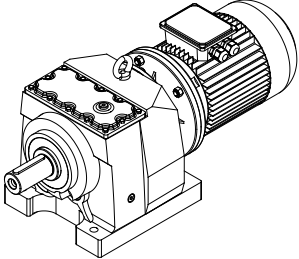
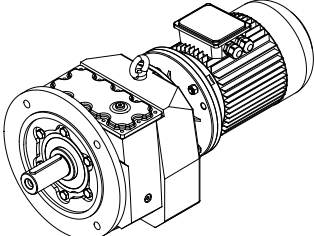
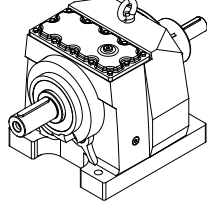
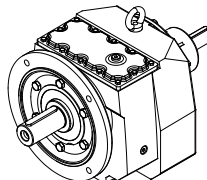
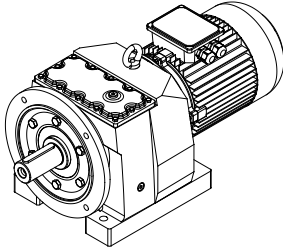
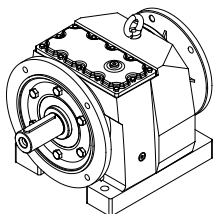
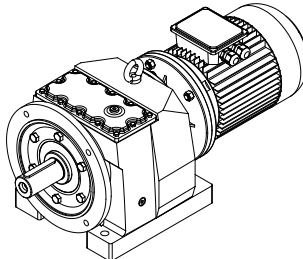
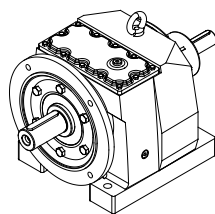
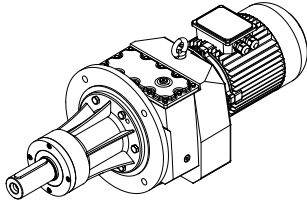
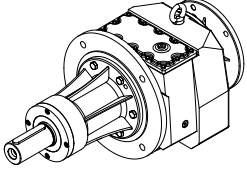
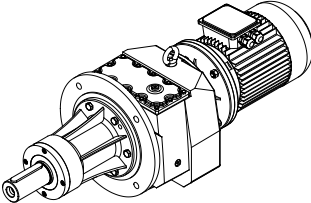
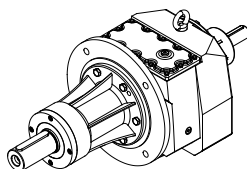

Tip Tanımlaması / Unit Designation / Typenbezeichnungen

 MR...	 NR...	 MN...	 NN...
 MV...	 NV...	 MT...	 NT...
 MRF...	 MNF...	 MVF...	 MTF...
 NRB...	 NNB...	 NVB...	 NTB...



Genel Bilgiler

General Information

Einführung



Örnek Tip Tanımlamaları

MR172 - 90S/4 - L05

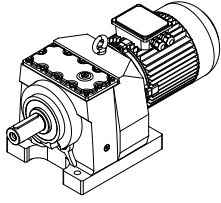

M.....: M serisi redüktör
R.....: Motor bağlantılı
1.....: Gövde büyüklük
7.....: Revizyon numarası
2.....: Kademe sayısı
90S.....: Motor büyüklüğü
4.....: Motor kutup sayısı
L05.....: Fren Tipi

MT373

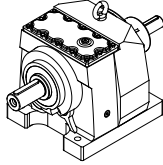

M.....: M serisi redüktör
T.....: Motorsuz giriş millî
3.....: Gövde büyüklüğü
7.....: Revizyon numarası
3.....: Kademe sayısı

MN473 - A11

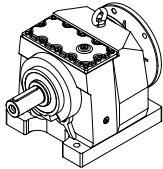

M.....: M serisi redüktör
N.....: Motorsuz ve IEC B5 giriş flanşlı
4.....: Gövde büyüklüğü
7.....: Revizyon numarası
3.....: Kademe sayısı
A11.....: 112 tip motor, B5 bağlantı flanşı

NRB473 - 100L/4

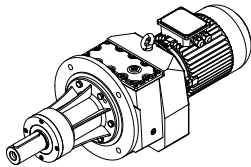

N.....: N serisi redüktör
R.....: Motorlu
B.....: Agitator boğazlı
4.....: Gövde büyüklüğü
7.....: Revizyon numarası
3.....: Kademe sayısı
100L.....: Motor büyüklüğü
4.....: Motor kutup sayısı

Sample Designations

MR172 - 90S/4 - L05

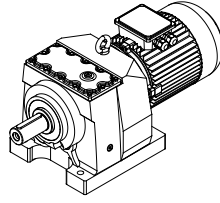

M.....: M series gearbox
R.....: With motor connection
1.....: Gear unit size
7.....: Revision number
2.....: Stage number
90S.....: Motor frame size
4.....: Number of poles
L05.....: Brake type

MT373

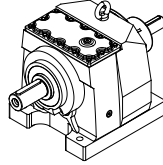

M.....: M series gearbox
T.....: Solid input shaft
3.....: Gear unit size
7.....: Revision number
3.....: Stage number

MN473 - A11

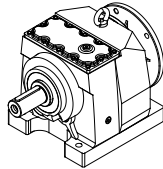

M.....: M series gearbox
N.....: IEC B5 flange without motor input
4.....: Gear unit size
7.....: Revision number
3.....: Stage number
A11.....: Motor type 112, B5 flange

NRB473 - 100L/4

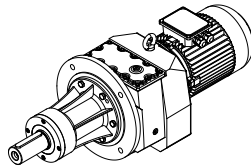

N.....: N series gearbox
R.....: With motor
B.....: Agitator flange
4.....: Gear unit size
7.....: Revision number
3.....: Stage number
100L.....: Motor size
4.....: Number of poles

Beispiele für Typenbezeichnung

MR172 - 90S/4 - L05

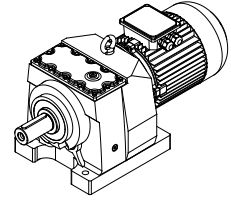

M.....: M Serie Getriebe
R.....: Motorverbindung
1.....: Größe der Gehäuse
7.....: Änderungsnummer
2.....: Stufenanzahl
90S.....: Motorbaugröße
4.....: Anzahl der Polen
L05.....: Bremse

MT373

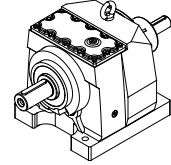

M.....: M Serie Getriebe
T.....: Vollwelleneingang ohne Motor
3.....: Größe der Gehäuse
7.....: Änderungsnummer
3.....: Stufenanzahl

MN473 - A11

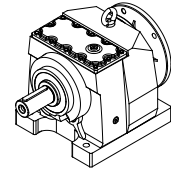

M.....: M Serie Getriebe
N.....: IEC B5 Flansch ohne Motor
4.....: Größe der Gehäuse
7.....: Änderungsnummer
3.....: Stufenanzahl
A11.....: Motortyp 112, B5 Motorflansch

NRB473 - 100L/4

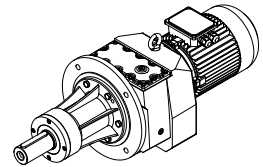

N.....: N Serie Getriebe
R.....: Mit Motor
B.....: Mischerhals
4.....: Größe der Gehäuse
7.....: Änderungsnummer
3.....: Stufenanzahl
100L.....: Motorbaugröße
4.....: Anzahl der Pole



Genel Bilgiler

General Information

Einführung



Motor Büyüklüğüne Göre Geometrik Mümkün Çevrim Oranları

Geometrically Possible Combinations of Ratios According to Motor Size

Geometrisch mögliche Kombinationen von Übersetzungen nach Motorbaugröße

Motor Büyüklüğü / Motor Size / Motorbaugröße

Tip Type Typ	Kademe Stages Stufen	63	71	80	90	100	112	132
MR002	2	3,62 - 11,14	3,62 - 11,14	3,62 - 11,14	3,62 - 11,14	-	-	-
MR003	3	13,61 - 45,18	13,61 - 45,18	13,61 - 32,02	13,61 - 32,02	-	-	-
MR102	2	3,94 - 15,95	3,94 - 15,95	3,94 - 15,95	3,94 - 15,95	-	-	-
MR103	3	17,33 - 50,51	17,33 - 50,51	17,33 - 50,51	17,33 - 50,51	-	-	-
MR172	2	3,38 - 20,92	3,38 - 20,92	3,38 - 20,92	3,38 - 20,92	3,38 - 18,28	3,38 - 6,60 11,08 - 12,66	-
MR173	3	26,10 - 99,21	26,10 - 99,21	26,10 - 99,21	26,10 - 99,21	26,10 - 87,60	26,10 - 30,26 49,81 - 57,76	-
MR202	2	3,50 - 23,01	3,50 - 23,01	3,50 - 23,01	3,50 - 23,01	3,50 - 20,10	3,50 - 13,92	-
MR203	3	23,23 - 68,03	23,23 - 68,03	23,23 - 68,03	23,23 - 68,03	23,23 - 24,77 36,02 - 59,43	36,02 - 41,16	-
MR272	2	3,16 - 25,89	3,16 - 25,89	3,16 - 25,89	3,16 - 25,89	3,16 - 21,43	3,16 - 16,07	-
MR273	3	19,00 - 138,55	19,00 - 138,55	19,00 - 138,55	19,00 - 138,55	19,00 - 121,03	19,00 - 83,83	-
MR275	5	149,02 - 1194,61	149,02 - 1194,61	149,02 - 1194,61	149,02 - 1194,61	-	-	-
MR276	6	1463,49 - 2920,17	1463,49 - 2920,17	1463,49 - 2920,17	1463,49 - 2920,17	-	-	-
MR282	2	-	4,20 - 6,25 9,61 - 30,37	4,20 - 6,25 9,61 - 30,37	4,20 - 6,25 9,61 - 30,37	3,15 - 25,23	3,15 - 19,06	3,15 - 14,31
MR283	3	-	18,33 - 27,80 41,96 - 137,91	18,33 - 27,80 41,96 - 137,91	18,33 - 27,80 41,96 - 137,91	18,33 - 114,14	18,33 - 85,60	18,33 - 27,80 41,96 - 63,65
MR284	4	158,52 - 431,18	158,52 - 431,18	158,52 - 431,18	158,52 - 431,18	-	-	-
MR285	5	376,94 - 1365,28	376,94 - 1365,28	376,94 - 1365,28	376,94 - 1365,28	-	-	-
MR286	6	1817,07 - 3214,82	1817,07 - 3214,82	1817,07 - 3214,82	1817,07 - 3214,82	-	-	-
MR372	2	-	13,53 - 23,33	13,53 - 23,33	13,53 - 23,33	3,28 - 23,33	3,28 - 20,62	3,28 - 16,20
MR373	3	-	18,68 - 20,64 29,47 ; 48,00 - 157,76	18,68 - 20,64 29,47 ; 48,00 - 157,76	18,68 - 20,64 29,47 ; 48,00 - 157,76	18,68 - 138,72	18,68 - 97,92	18,68 - 72,81
MR374	4	181,34 - 524,07	181,34 - 524,07	181,34 - 524,07	181,34 - 524,07	-	-	-
MR375	5	488,82 - 1561,78	488,82 - 1561,78	488,82 - 1561,78	488,82 - 1561,78	-	-	-
MR376	6	1217,14 - 4945,64	1217,14 - 4945,64	1217,14 - 4945,64	1217,14 - 4945,64	-	-	-
MR472	2	-	-	18,72 - 22,15	18,72 - 22,15	4,89 ; 8,47 - 22,15	4,89 ; 8,47 - 22,15	3,27 - 22,15
MR473	3	-	-	86,52 - 219,00	86,52 - 219,00	21,74 ; 30,93 - 157,90	18,04 - 139,54	18,04 - 109,64
MR474	4	-	229,46 - 674,46	229,46 - 674,46	229,46 - 674,46	229,46 - 295,98	229,46 - 259,55	-
MR475	5	726,85 - 2522,85	726,85 - 2522,85	726,85 - 2522,85	726,85 - 2522,85	726,85 - 1631,08	726,85 - 1386,75	-
MR476	6	2148,94 - 7458,85	2148,94 - 7458,85	2148,94 - 7458,85	2148,94 - 7458,85	2148,94 - 5141,34	2148,94 - 4822,33	-
MR572	2	-	-	-	-	17,07 - 27,00	17,07 - 27,00	4,95 - 27,00
MR573	3	-	-	-	-	26,54 - 167,32	22,64 - 134,45	22,64 - 118,95
MR574	4	-	144,37 - 574,90	144,37 - 574,90	144,37 - 574,90	144,37 - 402,12	144,37 - 194,15 301,59	144,37
MR575	5	620,62 - 2736,94	620,62 - 2736,94	620,62 - 2736,94	620,62 - 2736,94	-	-	-
MR576	6	2850,22 - 8091,82	2850,22 - 8091,82	2850,22 - 8091,82	2850,22 - 8091,82	-	-	-
MR672	2	-	-	-	-	-	20,74 - 23,18	5,08 - 5,73 10,62 - 23,18
MR673	3	-	-	-	-	-	110,55 - 196,61	30,20 - 174,89
MR674	4	-	-	-	215,97 - 500,39	215,97 - 500,39	215,97 - 442,20	-
MR675	5	-	730,46 - 2578,93	730,46 - 2578,93	730,46 - 2578,93	583,04 - 2578,93	583,04 - 1113,08	583,04 - 995,91
MR676	6	-	2863,86 - 17441,07	2863,86 - 17441,07	2863,86 - 17441,07	2863,86 - 7490,08	2863,86 - 5287,12	2863,86 - 3931,45
MR772	2	-	-	-	-	-	-	7,26
MR773	3	-	-	-	-	-	-	12,98 - 21,40 17,53 - 19,76 ; 34,89 - 39,33 68,15 - 208,82
MR774	4	-	-	-	190,96 - 594,92	190,96 - 594,92	190,96 - 594,92	190,96 - 467,43
MR775	5	-	641,40 - 4812,09	641,40 - 4812,09	641,40 - 4812,09	641,40 - 3103,85	641,40 822,02 - 1252,60	822,02 - 984,18
MR776	6	-	2916,59 - 23464,25	2916,59 - 23464,25	2916,59 - 23464,25	2916,59 - 8428,93	2916,59 - 5949,83	2916,59 - 4424,24
MR872	2	-	-	-	-	-	-	-
MR873	3	-	-	-	-	-	-	56,54 - 110,17
MR874	4	-	-	-	-	188,08 - 446,42	188,08 - 390,74	107,60 - 345,67
MR875	5	-	537,75 - 1924,32	537,75 - 1924,32	537,75 - 1924,32	495,97 - 1924,32	495,97 - 1700,56	495,97 - 1336,15
MR876	6	-	2108,33 - 17501,59	2108,33 - 13014,00	2108,33 - 13014,00	2108,33 - 11443,34	2108,33 - 3892,30	2108,33 - 2894,28
MR972	2	-	-	-	-	-	-	-
MR973	3	-	-	-	-	-	-	-
MR974	4	-	-	-	-	172,08 - 510,11	172,08 - 510,11	172,08 - 510,11
MR975	5	-	-	914,74 - 2027,97	914,74 - 2027,97	588,87 - 2027,97	588,87 - 2027,97	462,18 - 2027,97
MR976	6	-	-	2836,64 - 20051,59	2836,64 - 20051,59	2836,64 - 11064,86	2836,64 - 8620,11	2836,64 - 5357,43



Genel Bilgiler

General Information

Einführung



Motor Büyüklüğüne Göre Geometrik Mümkün Çevrim Oranları

Geometrically Possible Combinations of Ratios According to Motor Size
Geometrisch mögliche Kombinationen von Übersetzungen nach Motorbaugröße

Motor Büyüklüğü / Motor Size / Motorbaugröße

Tip Type Typ	Kademe Stages Stufen	160	180	200	225	250	280	315
MR002	2	-	-	-	-	-	-	-
MR003	3	-	-	-	-	-	-	-
MR102	2	-	-	-	-	-	-	-
MR103	3	-	-	-	-	-	-	-
MR172	2	-	-	-	-	-	-	-
MR173	3	-	-	-	-	-	-	-
MR202	2	-	-	-	-	-	-	-
MR203	3	-	-	-	-	-	-	-
MR272	2	-	-	-	-	-	-	-
MR273	3	-	-	-	-	-	-	-
MR275	5	-	-	-	-	-	-	-
MR276	6	-	-	-	-	-	-	-
MR282	2	-	-	-	-	-	-	-
MR283	3	-	-	-	-	-	-	-
MR284	4	-	-	-	-	-	-	-
MR285	5	-	-	-	-	-	-	-
MR286	6	-	-	-	-	-	-	-
MR372	2	3,28 - 13,53	-	-	-	-	-	-
MR373	3	21,65 - 25,27 35,25 - 41,16	-	-	-	-	-	-
MR374	4	-	-	-	-	-	-	-
MR375	5	-	-	-	-	-	-	-
MR376	6	-	-	-	-	-	-	-
MR472	2	3,27 - 18,72	3,27 - 15,35	-	-	-	-	-
MR473	3	18,04 - 84,46 ; 91,58	18,04 - 73,09	-	-	-	-	-
MR474	4	-	-	-	-	-	-	-
MR475	5	-	-	-	-	-	-	-
MR476	6	-	-	-	-	-	-	-
MR572	2	4,37 - 23,02	4,37 - 19,15	4,37 - 14,54	-	-	-	-
MR573	3	22,64 - 100,53	22,64 - 39,98 54,74 - 82,45	-	-	-	-	-
MR574	4	-	-	-	-	-	-	-
MR575	5	-	-	-	-	-	-	-
MR576	6	-	-	-	-	-	-	-
MR672	2	3,29 - 23,18	3,29 - 23,18	3,29 - 17,93	3,29 - 11,97	-	-	-
MR673	3	26,66 - 149,11	26,66 - 124,07	26,66 - 94,17	26,66 - 34,36 53,99 - 61,42	-	-	-
MR674	4	-	-	-	-	-	-	-
MR675	5	583,04 - 673,70	-	-	-	-	-	-
MR676	6	-	-	-	-	-	-	-
MR772	2	4,73 - 21,40	4,73 - 21,40	4,73 - 21,40	4,73 - 14,54	4,73 - 14,54	-	-
MR773	3	15,63 - 178,78	15,63 - 148,73	15,63 - 115,06	15,63 - 76,81	15,63 - 76,81	-	-
MR774	4	-	-	-	-	-	-	-
MR775	5	-	-	-	-	-	-	-
MR776	6	-	-	-	-	-	-	-
MR872	2	4,95 ; 5,99 - 10,09	4,95 ; 5,99 - 10,09	4,32 - 10,09	4,32 - 10,09	4,32 - 10,09	4,32 - 10,09	-
MR873	3	13,30 ; 16,09 - 20,28 27,39 - 110,17	13,30 ; 16,09 - 20,28 27,39 - 110,17	11,59 - 86,51	11,59 - 52,86	11,59 - 52,86	11,59 - 46,12	-
MR874	4	107,60 - 292,15	107,60 - 239,61	107,60 - 174,68	-	-	-	-
MR875	5	495,97 - 537,75	-	-	-	-	-	-
MR876	6	-	-	-	-	-	-	-
MR972	2	7,92 - 9,99 ; 12,86 - 16,23	7,92 - 9,99 ; 12,86 - 16,23	7,11 - 16,23	7,11 - 16,23	7,11 - 16,23	7,11 - 16,23	7,11 - 16,23
MR973	3	20,36 - 26,03 ; 33,08 - 42,30 54,80 - 186,95	20,36 - 26,03 ; 33,08 - 42,30 54,80 - 166,73	18,15 - 132,83	18,15 - 91,56	18,15 - 91,56	18,15 - 70,07	18,15 - 70,07
MR974	4	172,08 - 216,03	172,08 - 193,13	-	-	-	-	-
MR975	5	462,18 - 842,80	462,18 - 750,24	-	-	-	-	-
MR976	6	-	-	-	-	-	-	-



Genel Bilgiler General Information Einführung



Servis Faktörü

Servis faktörü (fs) redüktörün çalıştığı şartlar ile uyumlu olması için gerekli olan emniyet katsayısıdır. "fs =1" Düzgün ve sakin yüklerde, günlük sekiz saat ve saatte yüz start çalışmayı karşılar.

Aşağıdaki etkenlere bağlıdır:

- Günlük çalışma süresi
- Yük sınıfı
- Bir saatteki start sayısı
- Redüktör tahrik tipi
- Diğer gözlemler

Bu etkenleri göz önüne aldığımızda, gerekli servis faktörünü belirlemek için:

1. Makinanın günlük çalışma süresini tespit ediniz.
2. Makinanın ne türde yükler verdiğini tespit ediniz (Sayfa 17-18).

- U - Düzgün ve sabit yükler
- M - Orta darbeli yükler
- H - Ağır darbeli yükler

Yük sınıfının daha teknik seçimi için rotora indirgenmiş toplam atalet momenti formülünden faydalanabilirsiniz (Sayfa 18).

3. Saatteki start sayısını tespit ediniz.
4. İlk üç maddeye bağlı servis faktörünü aşağıdaki tablodan seçiniz.

5. fs Redüktörümüzün tahrik tipine bağlı olarak "k" katsayısı ile çarpılarak artırılır.

- k=1 :Elektrik motoru veya hidromotor
- k=1.25 :İçten yanmalı çok silindirli motor
- k=1.5 :İçten yanmalı tek silindirli motor

Service Factor

Service Factor (fs) is a safety coefficient, which takes into account the different running conditions of the driven machine. "fs=1" is used for uniform loads 8 hours working per day and up to 100 starts per hour.

Service factor depends on:

- Running time
- Nature of load
- Frequency of starting
- Driver type
- Other considerations

For the right selection of the needed service factor for your machine;

1. Determine the running time of driven machine.
2. Select the nature of load of driven machine (Page 17-18).

- U - Uniform loads
- M - Moderate loads
- H - Heavy shock loads

For a better selection, the nature of load can be calculated from the formulas given (page 18).

3. Determine frequency of starting
4. After determining the above mentioned factors, the service factor can be easily selected from the table given below.
5. The selected service factor must be multiplied with the factor "k" according to the driver type;

- k=1 :Electric motor or Hydrolicmotor
- k=1.25 :Multicylinder internal combustion engine
- k=1.5 :Single cylinder internal combustion engine

Betriebsfaktor

Der Betriebsfaktor (fs) ist ein Sicherheitsfaktor für die Getriebe, damit sie unter den Betriebsbedingungen sicher arbeiten. "fs =1" steht für gleichförmige Belastung, 8 Stunden pro Tag und bis zu 100 Schaltungen pro Stunde.

Betriebsfaktor ist abhängig von:

- Betriebsdauer
- Belastungsart
- Schalthäufigkeit
- Antriebsart
- Andere Faktoren

Um die richtigen Betriebsfaktor festzulegen;

1. Betriebsdauer der angetriebenen Maschine bestimmen.
2. Belastungsart der angetriebenen Maschine auswählen.

- U - Gleichförmig Belastung
- M - Ungleichförmig Belastung
- H - Stark Ungleichförmig Belastung

Um eine bessere Auswahl zu treffen, können die Belastungsarten mit den angegebenen Formeln (Seite 18) errechnet werden.

3. Schalthäufigkeit bestimmen.
4. Nach Bestimmen der oben angegebenen Werte, können die Betriebsfaktoren von der unten stehenden Tabelle entnommen werden.
5. Der ausgewählte Betriebsfaktor muß mit dem Faktor "k" abhängig von der Antriebsart multipliziert werden

- k=1 :Elektromotor oder Hydraulikmotor
- k=1.25 :Vielzylindermotor
- k=1.5 :Einzyldermotor

Günlük Çalışma Süresi
Operating Time hour / Day
Laufzeit Std. / Tag

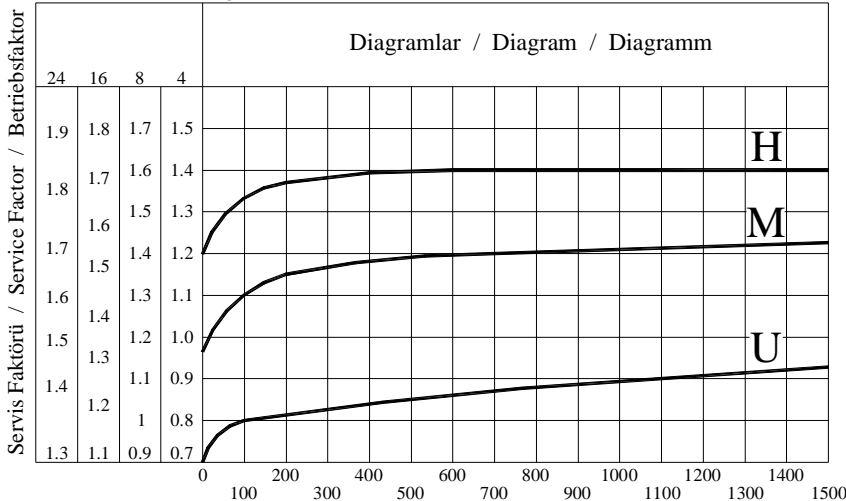

Start sayısı / Saat
Cycle / Hour
Schaltungen / Std.



Genel Bilgiler

General Information

Einführung



Yük Sınıflandırması

Krenler:

- U - Kaldırma Dişlileri
- Palanga Dişlileri
- M - Bomlu Vinç Dişlileri
- Yana Döndürme Dişlileri
- H - Yürütme Dişlileri

Pompalar:

- U - Santrifuj Pompalar (ince sıvı)
- M - Santrifuj Pompalar (yarı sıvı)
- H - Basınçlı Pompalar
- Dalgıç Pompalar

Taş ve Kil İşleme Makinaları:

- H - Çekiçli Değirmenler
- Döner Fırınlar
- Dövücü Değirmenler
- Kırıcılar
- Kürel Değirmenler
- Tuğla Presi
- Tüp Değirmenler

Tekstil Makinaları:

- M - Basma ve Boyama Makinaları
- Dokuma Tezgahları
- Hallac Makinaları
- Harman Makinaları
- Taneleme (Debegat) Tekneleri

Yağ Sanayi:

- M - Besleme Pompaları
- Döner Delme Teçhizatları

Yiyecek Sanayi:

- M - Kutu Bıçaklar
- Kutu Kaplama
- Mayalama Tekneleri
- H - Kenar Açma

Çamaşır Yıkama Makinaları:

- M - Döner Kurutucular
- Yıkama Makinaları

Hadde Makinaları:

- M - Hız Ayarlı Silindirler
- Sabit Silindirler
- Sarma Makaraları
- Tel Çekme
- H - Çubuk Kesme Makinaları
- Döner Tablalar (büyük)
- Kabuk Sıyırma Makinaları
- Plaka Haddeleme
- Silindir Haddeleme
- Soğuk Haddeleme

Load Classification

Cranes:

- U - Hoist Gears
- Lifting Gears
- M - Defrocking jib Gears
- Slowing Gears
- H - Travelling Gears

Pumps:

- U - Centrifugal Pumps (light liquids)
- M - Centrifugal Pumps (semi liquid)
- H - Pressure Pumps
- Plunger Pumps

Stone and Clay Working Machines:

- H - Hammer Mills
- Rotary Kilns
- Beater Mills
- Breakers
- Ball Mills
- Brick Presses
- Tup Mills

Textile Machines:

- M - Printing and Dyeing Machines
- Looms
- Willow
- Batchers
- Tanning Vats

Oil Industry:

- M - Pipeline Pumps
- Rotary Drilling Equipment

Food Industry:

- M - Cane Knives
- Cane Crushers
- Mach Tubs
- H - Cane Mills

Laundries:

- M - Tumblers
- Washing Machines

Metal Rolling Mills:

- M - Roller Adjustment Drives
- Roller Straightened
- Winding Machines
- Wire Drawing Benches
- H - Billet Shears
- Rotary Tables (heavy)
- Descaling Machines,
- Sheet Mills
- Manipulators
- Cold Rolling Mills

Belastungsart

Krananlagen:

- U - Einziehwerke
- Hubwerke
- M - Schwenkwerke
- Wippwerke
- H - Fahrwerke

Pumpen:

- U - Kreiselpumpen (leichte Flüssigkeit)
- M - Kreiselpumpen (zähe Flüssigkeit)
- H - Prebpumpen
- Plungerpumpen

Steine und ErdenBearbeitendeMasch.

- H - Hammermühlen
- Drehofen
- Schlagmühlen
- Brecher
- Kugelmühlen
- Ziegelpressen
- Rohrmühlen

Textilmaschinen:

- M - Drukerei
- Farbereimachinen
- Aufwickler
- Webstühle
- Gerbfasser
- Reibwolfe

Erdölgewinnung:

- M - Pipeline Pumpen
- Rotative Bohranlagen

Nahrungsmittelmachinen:

- M - Rohrschneiden
- Knetmaschinen
- Maichen
- H - Rohrmühlen

Waschereimaschinen:

- M - Trommeltrockner
- Waschmaschinen

Wälzwerke:

- M - Rollenrichtmaschinen
- Walzenantriebe
- Drahtzuge
- Haspeln
- H - Blechscheren
- Rollgänge (schwer)
- Knüppelscheren
- Schöpfscheren
- Stranggubanlagen
- Kaltwälzwerke



Genel Bilgiler

General Information

Einführung



İnşaat Makinaları:

- M - Beton Mikserleri
- Ağır Yük Asansörleri

Kağıt Makinaları:

- H - Islak Presler
- Kağıt Hamur Makinaları
- Kurutma Silindirleri
- Perdahlama Silindirleri

Kauçuk Makinaları:

- M - Kalenderler
- Mikserler
H - Extruderler
- Hamur Karma
- Silindirler

Kimya Sanayi:

- M - Agidatörler (yarı sıvı)
- Kurutma Merdaneleri
- Mikserler ve Silindirleri

Konveyörler:

- M - Bant Cepeli Konveyörler
- Çelik Bantlı Konveyörler
- Dökme Yüklü Kayışlı Konv.
H - Yük Asansörleri
- Parça Yüklü Kayışlı Konv.

Building Machines:

- M - Concrete Mixers
- Hoist

Paper Machines:

- H - Wet Presses
- Pulpers
- Drying Cylinders
- Glazing Cylinders

Rubber Machinery:

- M - Calenders
- Mixers
H - Extruders
- Pug Mills
- Rolling Mills

Chemical Industry:

- M - Aggidators (semi- liquid)
- Drying Drums.
- Mixers and Rolling Mills

Conveyors:

- M - Band Pocket Conveyors
- Steel Belt Conveyors
- Belt Conveyors
H - Hoists
- Bulk Belt Conveyors

Baumaschinen:

- M - Betonmischermaschinen
- Bauaufzüge

Papiermaschinen:

- H - Naßpressen
- Gautschen
- Trockenzyylinder
- Glattzyylinder

Kunststoffmaschinen:

- M - Kalender
- Mischer
H - Extruder
- Knetwerke
- Wälzwerke

Chemische Industrie:

- M - Rührwerke (leichte Flüssig.)
- Trockentrommeln
- Mischer und Wälzwerke

Förderanlagen:

- M - Gurtaschenbecherwerke
- Stahlbandförderer
- Gurtbandförderer (Schüttgut)
H - Schrägaufzüge
- Gurtbandförderer (Stückgut)

U	Uniform Yük Uniform Loads Gleichförmige Last	$F_i < 0,25$
M	Orta Darbeli Yük Moderate Loads Ungleichförmige Last	$F_i < 3$
H	Darbeli Yük Heavy Shock Loads Stark Ungleichförmige Last	$F_i < 10$

$$J'_{\text{ext}} = \frac{J_{\text{ext}}}{i^2}$$

$$F_i = \frac{J'_{\text{ext}}}{J_{\text{rotor}}}$$

J_{ext} : **Motor miline indirgenmiş toplam dış atalet momenti**
External moments of inertia reduced to the motor shaft
Externe massenträgheitsmomente reduziert auf motorwelle

i : **Tahvil oranı**
Transmission ratio
Übersetzung

J_{rotor} : **Motorun atalet momenti**
Moments of inertia to the motor
Massenträgheitsmoment



Genel Bilgiler

General Information

Einführung



Redüktör Dönüş Yönleri

M Serisi ürünlerimiz için kullanılan yön tanımlaması aşağıdaki gibidir. Aşağıdaki tanımlama kilitli redüktörler için de geçerlidir.

Direction of Rotation

M Series direction of rotation of Yılmaz products are defined as follows. The definitions are also valid for gear units with backstop.

Getriebedrehrichtungen

Die Drehrichtungen für M Serie Getriebe sind wie folgt definiert. Die Definition ist auch bei Getrieben mit Rücklaufsperre gültig.

	2-4-6 Kademe / 2-4-6 Stages / 2-4-6 stufig	3-5 Kademe / 3-5 Stages / 3-5 stufig
Saat Yönünde Clockwise im Uhrzeigersinn CW		
Saat Tersi Yönünde Counter Clockwise gegen Uhrzeigersinn CCW		

Giriş mili dönüş yönüne göre çıkış mili dönüş yönleri aşağıdaki gibidir.

Output shaft rotation directions according to the input shaft rotation directions are as follows.

Drehrichtungen der Abtriebswelle im Abhängigkeit von der Antriebswellen sind wie folgt;

2-4-6 Kademe / 2-4-6 Stages / 2-4-6 stufig	3-5 kademe / 3-5 Stages / 3-5 stufig



Genel Bilgiler

General Information

Einführung



Radyal Yükler

Çıkış miline gelebilecek radyal ve eksenel yükler yatak ömrüne göre belirlenmiş ve tablolar halinde verilmiştir. Bu tablolarda verilen F_{qam} güvenilir radyal yükü emniyet katsayısı 1 için ve yükün mil ortasını yüklediği durum için verilmiştir. Darbeli yüklerin olması ($f_s \neq 1$) durumunda izin verilen radyal yük değerleri servis faktörü kadar azaltılmalıdır. Verilen radyal ve eksenel yükler kuvvetin en kötü açı şartında etki ettiği durum için verilmiştir. Mil ucuna gelen kuvvetin açısına göre daha yüksek radyal yükler mümkündür (Firmamıza danışınız). Bağlantı şekline göre oluşan radyal yük F_q sayfa 21 de verilen formüller yardımı ile hesaplanır. Redüktör seçiminde ;

$$\begin{aligned} F_{qa} &\leq F_{qam} \\ F_{qe} &\leq F_{qem} \end{aligned}$$

şartı göz önünde tutulmalı. Eğer etkiyen radyal kuvvet milin orta noktasında değil ise verilen güvenilir değerler aşağıda verilen formül ile düzeltilmesi gerekir.

$$\begin{aligned} F_{qam}' &= F_{qam} \times \frac{t}{y+u} \\ F_{qem}' &= F_{qem} \times \frac{t}{y+u} \end{aligned}$$

"t", "y" Değerleri aşağıda verilmiştir. "u" Değeri görüldüğü gibi kuvvetin uygulama noktasıdır.

Overhung Loads

The permissible overhung loads are calculated by considering working life and is listed on the tables. The given permissible overhung loads F_{qam} are based on safety factor 1 and are valid for forces which are applied to the midpoint of the shaft.

For shock loading ($f_s \neq 1$) permissible radial loads must be divided with service factor. The listed permissible overhung loads are based on the worst loading direction. Higher overhung loads can be applied for different loading directions (Please ask if requested). The effective overhung load at the gearbox shaft F_q will be determined with the given formulas on page 21.

In Selection ;

$$\begin{aligned} F_{qa} &\leq F_{qam} \\ F_{qe} &\leq F_{qem} \end{aligned}$$

these formulas must be taken into consideration. If the load is not applied at the midpoint of the shaft; the given permissible load must be corrected with the following formulas.

$$\begin{aligned} F_{qam}' &= F_{qam} \times \frac{t}{y+u} \\ F_{qem}' &= F_{qem} \times \frac{t}{y+u} \end{aligned}$$

The values "t", "y" can be taken from the below table. The value "u" is the length of the application point as shown below.

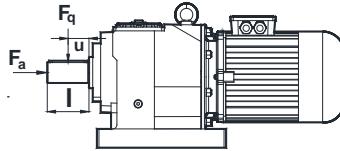

Querkräfte

Die in den nachfolgenden Tabellen angegebenen zulässigen Radialbelastungen F_{qam} gelten bei Kraftangriff auf die Mitte Wellenendes. Den Angaben liegt der Sicherheitsfaktor gleich 1 zu Grunde. Bei stoßartigen Belastungsfällen ist auch hier der entsprechende Betriebsfaktor ($f_s \neq 1$) zu berücksichtigen. Zulässige Axialkräfte F_{ama} oder F_{ame} wurden für den Fall mit schlechter Belastungsrichtung angegeben. Bei der Ermittlung der zulässige Querkräfte sind höhere Werte möglich (Bitte Rückfragen). Die auftretende Querkraft F_q ab der Getriebewelle wird wie in der nachfolgenden Formel bestimmt.

Bei dieser Auswahl;

$$\begin{aligned} F_{qa} &\leq F_{qam} \\ F_{qe} &\leq F_{qem} \end{aligned}$$

müssen die oben angegebenen Bedingungen berücksichtigt werden. Ist der Kraftangriff nicht auf Wellenmitte, so kann die zulässige Querkraft mit Hilfe der unten stehenden Formel auf jede beliebige Stelle umgerechnet werden.

$$\begin{aligned} F_{qam}' &= F_{qam} \times \frac{t}{y+u} \\ F_{qem}' &= F_{qem} \times \frac{t}{y+u} \end{aligned}$$

Die Werte "t" und "y" sind in den nachfolgenden Tabellen angegeben. Der Wert "u" ist die Stelle des Kraftangriffs wie auf der nächsten Seite angegeben.

Çıkış Milinde Radyal Kuvvet Hesabı Düzeltme Katsayıları

Overhung Load Correcting Values on Output Shaft
Querkraft auf Ausgangswelle Korrigierungszahlen

Tip Type Typ	MR002-003 NR002-003	MR102-103 NR102-103	MR172-173 NR172-173	MR202-203 NR202-203	MR272-273 NR272-273	MR282-283 NR282-283	MR372-373 NR372-373	MR472-473 NR472-473	MR572-573 NR572-573	MR672-673 NR672-673	MR772-773 NR772-773	MR872-873 NR872-873	MR972-973 NR972-973
t	90	108	109	140	141	158	170	214	256	291	314	404	440
y	70	83	84	110	106	123	130	164	196	226	244	299	334
l	40	50	50	60	70	70	80	100	120	130	140	210	210

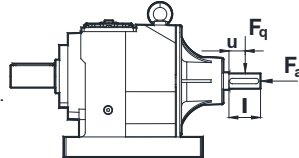

Giriş Milinde Radyal Kuvvet Hesabı Düzeltme Katsayıları

Overhung Load Correcting Values on Input Shaft
Querkraft auf Eingangswelle Korrigierungszahlen

Tip Type Typ	MT002-003 NT002-003	MT102-103 NT102-103	MT172-173 NT172-173	MT202-203 NT202-203	MT272-273 NT272-273	MT282-283 NT282-283	MT372-373 NT372-373	MT472-473 NT472-473	MT572-573 NT572-573	MT672-673 NT672-673	MT772-773 NT772-773	MT872-873 NT872-873	MT972-973 NT972-973
t	78	108	108	111	111	126	126	137	158	180	207	220	261
y	58	83	83	86	86	96	96	102	113	130	147	165	207
l	40	50	50	50	50	60	60	70	90	100	120	110	110



Genel Bilgiler

General Information

Einführung



Radyal Yüklerin Hesabı

Radyal Yük $F_q(N)$ 'nin hesaplanmasında, gerekli tahrik momenti M (Nm), kasnak veya dişli çapı D (mm) olmak üzere aşağıdaki formüller kullanılır.

1. Elastik Kaplin

Çalışma sırasında oluşan sapmalar kaplinin güvenlik sınırları içinde ise kuvvetler ihmal edilebilir.

2. Düz Dişli

(20° kavrama açılı)

$$F_q = \frac{2100 \times M_2}{D}$$

3. Küçük Hızlarda Zincir Dişli ($z > 17$)

$$F_q = \frac{2100 \times M_2}{D}$$

4. Triger Kayış

$$F_q = \frac{2500 \times M_2}{D}$$

5. V Kayış

$$F_q = \frac{5000 \times M_2}{D}$$

6. Gerdirme Makaralı Kayış

$$F_q = \frac{5000 \times M_2}{D}$$

Calc. Of Overhung Loads

Radial Load $F_q(N)$ is calculated with the following equations where required moment M (Nm) and hoop or gear diameter D (mm) is used.

1. Elastic Coupling

If Elastic Coupling is working in its reliable working area, the overhung loads can be neglected.

2. For Spur Gear (Pressure angle 20°)

$$F_q = \frac{2100 \times M_2}{D}$$

3. For Chain Drive With Low Speed ($z > 17$)

$$F_q = \frac{2100 \times M_2}{D}$$

4. For Trigger Belt

$$F_q = \frac{2500 \times M_2}{D}$$

5. For V Belt

$$F_q = \frac{5000 \times M_2}{D}$$

6. Flat Belt With Spanning Pulley

$$F_q = \frac{5000 \times M_2}{D}$$

Berechnung der Querkräfte

Der Fall der radialen Belastung $F_q(N)$ kann mit den angegebenen Gleichungen berechnet werden. Antriebsmoment M (Nm) und Zahnrad- oder Riemenscheiben Durchmesser D (mm).

1. Elastische Kupplung

Wenn die elastische Kupplung in ihren zulässige Arbeitstoleranz arbeitet, können die radialen Belastungen vernachlässigt werden.

2. Stirnradgetriebe (Angriffswinkel 20°)

$$F_q = \frac{2100 \times M_2}{D}$$

3. Kettenantrieb mit niedriger Geschwindigkeit ($z > 17$)

$$F_q = \frac{2100 \times M_2}{D}$$

4. Zahnriemenantrieb

$$F_q = \frac{2500 \times M_2}{D}$$

5. Keilriemenantrieb

$$F_q = \frac{5000 \times M_2}{D}$$

6. Flachriemenantrieb mit Spannungstrommel

$$F_q = \frac{5000 \times M_2}{D}$$





Genel Bilgiler

General Information

Einführung



Eşdeğer Güç Hesabı

Sabit devirde, ancak değişken momentlerde (güçlerde) çalışan redüktörler için eşdeğer tork altındaki, eşdeğer güç hesaplanabilir. Bu eşdeğer güç kullanılarak bilinen sabit güçteki redüktör seçim yöntemi kullanılarak seçim yapılabilir. Burada ağırlıklı torka göre eşdeğer anma torku belirlenmektedir. Hesaplanan bu güçte çalışan redüktör, teorik olarak, değişken yüklerde çalışan redüktör ile aynı emniyet değerine ve ömre sahiptir.

Bir çevrim boyunca oluşan değişken torklar, en yüksek torktan, en düşüğe doğru yatay zaman eksenini boyunca sıralanır (bakınız alttaki şekil). Bu şekile göre eşdeğer tork şu formül ile hesaplanır;

$$T_e = \left(\frac{\Delta t_1 \times T_1^{6.6} + \dots + \Delta t_n \times T_n^{6.6}}{t} \right)^{\frac{1}{6.6}}$$

Eğer T_n değerleri (en düşük tork), T_e 'nin 0,5 katının altında ise, bu tork dilimi yok sayılarak, işlem tekrarlanır;

Eğer $T_n < T_e \times 0.5$ ise

$$T_e = \left(\frac{\Delta t_1 \times T_1^{6.6} + \dots + \Delta t_{n-1} \times T_{n-1}^{6.6}}{t - \Delta t_n} \right)^{\frac{1}{6.6}}$$

Tüm T_n değerleri T_e 'nin 0,5 katının üzerinde ise, eşdeğer güç aşağıdaki gibi hesaplanır;

$$P_{eq} = P_N = \frac{T_e \times n}{9550}$$

Eşdeğer gücün bulunmasından sonra eşdeğer güç değeri kullanılarak, bu katalogta verilen redüktör seçimi bölümünde anlatılan adımlar uygulanarak redüktör seçimi tamamlanır.

Equivalent Power Rating Calculation

The equivalent power by an equivalent constant torque can be calculated for gearboxes working in constant speed but variable torques (or powers). Using this equivalent power it is possible to make a gearbox selection according to the usual gearbox selection method with constant torques. The equivalent torque will be determined according to the mean of dominating torques. The gearbox working in constant equivalent torque will theoretically have the same lifetime and safety compared to the variable torque one.

To calculate the equivalent torques, the variable torques in a cycle must be sorted from the maximal to the minimal on a horizontal time line (Check the graphic below). According to the graphic below the equivalent torque can be calculated with the following formula;

$$T_e = \left(\frac{\Delta t_1 \times T_1^{6.6} + \dots + \Delta t_n \times T_n^{6.6}}{t} \right)^{\frac{1}{6.6}}$$

If T_n (the lowest torque) is lower than 50 % of T_e , this torque part must be taken out of the torque graph and the calculation must be repeated;

If $T_n < T_e \times 0.5$ then

$$T_e = \left(\frac{\Delta t_1 \times T_1^{6.6} + \dots + \Delta t_{n-1} \times T_{n-1}^{6.6}}{t - \Delta t_n} \right)^{\frac{1}{6.6}}$$

If all T_n values are higher than 50% of T_e then the equivalent power can be calculated by the following formula;

$$P_{eq} = P_N = \frac{T_e \times n}{9550}$$

After the equivalent power is determined the selection of gearbox is made according to the selection procedures given on the gearbox selection part in this catalogue.

Berechnung Äquivalenter Leistung

Die äquivalente Leistung bei äquivalenten Drehmoment kann für Getrieben mit konstanten Drehzahl und variablen Momente berechnet werden. Mit dieser Leistung kann das Getriebe ausgelegt werden, wie bei konstanten Leistung. Man bestimmt hiermit also die maßgebende Belastung. Das ausgelegte Getriebe erreicht theoretisch dem gleichen Lebensdauer und hat die gleiche Sicherheit.

Für die Berechnung der äquivalenten Drehmoment müssen die einzelnen Drehmomentanteile auf eine Zeitachse von größten bis zu kleinsten angeordnet werden (siehe unteres Bild). Das äquivalente Drehmoment wird nach folgender Formel berechnet;

$$T_e = \left(\frac{\Delta t_1 \times T_1^{6.6} + \dots + \Delta t_n \times T_n^{6.6}}{t} \right)^{\frac{1}{6.6}}$$

Wenn T_n (niedrigstes Drehmoment) kleiner als 50% von T_e ist, muss dieser Anteil vernachlässigt werden und die Berechnung soll neu durchgeführt werden;

Wenn $T_n < T_e \times 0.5$ dann

$$T_e = \left(\frac{\Delta t_1 \times T_1^{6.6} + \dots + \Delta t_{n-1} \times T_{n-1}^{6.6}}{t - \Delta t_n} \right)^{\frac{1}{6.6}}$$

Wenn alle T_n Werte höher als 50% von T_e sind, dann wird die äquivalente Leistung nach folgender Formel berechnet;

$$P_{eq} = P_N = \frac{T_e \times n}{9550}$$

Nach Bestimmung der äquivalenter Leistung, erfolgt die Getriebeauslegung wie bei konstanter Leistung. Die Auswahlverfahren für konstante Leistung ist in diesem Katalog angegeben.

(Moment / Torque / Moment)

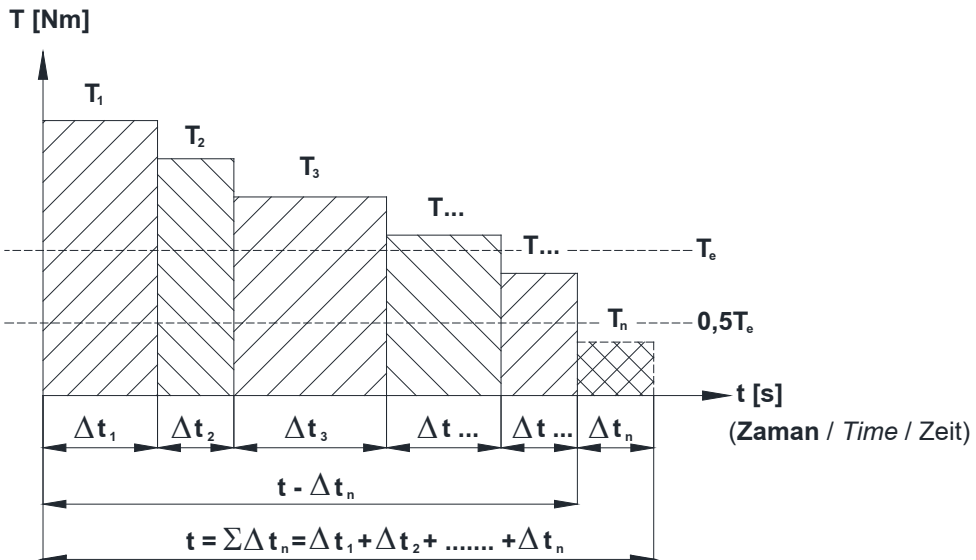



Genel Bilgiler

General Information

Einführung



Eşdeğer Güç Hesabı Örneği

Çift yönlü çalışan ham demir haddesi için aşağıdaki çalışma koşulları belirlenmiş;

Veriler:

Toplam bir iş çevrimi: 2 dak.

1. Yük kademesi: 48 kNm, 30 s
2. Yük Kademesi: 32 kNm, 22 s
3. Yük Kademesi: 28 kNm, 15 s
4. Yük Kademesi: 16 kNm, 10 s
5. Yük Kademesi: 5 kNm, 43 s

Makina sabit devri: 50 d/dak

Redüktör seçimine esas olacak eşdeğer yük aranmaktadır.

Çözüm:

Bir çevrimin toplam zamanı;

$$t = t_1 + t_2 + t_3 + t_4 + t_5 = 120 \text{ sn}$$

Eşdeğer Tork;

$$T_e = \left(\frac{30 \times 48^{6.6} + \dots + 43 \times 5^{6.6}}{120} \right)^{\frac{1}{6.6}}$$
$$= 39,2 \text{ kNm}$$

%50 eşdeğer tork;

$$0.5 \times T_e = 19.6 \text{ kNm}$$

Her bir tork dilimi bu değerin üzerinde olmalı

$$T_4, T_5 < 0.5 \times T_e$$

%50 torkun altındakileri çıkararak hesabı tekrarlayalım;

$$t' = t - t_4 - t_5 = 120 - 43 - 10 = 67 \text{ s}$$

$$T_e = \left(\frac{30 \times 48^{6.6} + \dots + 15 \times 28^{6.6}}{67} \right)^{\frac{1}{6.6}}$$
$$= 42,9 \text{ kNm}$$

Moment ve devir değerlerini kullanarak eşdeğer gücümüzü hesaplayalım ;

$$P_{eq} = \frac{T_e \times n}{9550} = \frac{42,9 \times 1000 \times 50}{9550} \cong 225 \text{ kW}$$

Yukarıdaki güç ve devir değeri kullanılarak bu katalogta anlatılan seçim presüdüğü ile redüktör seçimi yapılabilir.

Equivalent Power Rating Sample

The following data is given for a reversing blooming mill;

Torque steps:

Total one cycle time: 2 min.

1st torque part: 48 kNm, 30 s

2nd torque part: 32 kNm, 22 s

3th torque part: 28 kNm, 15 s

4th torque part: 16 kNm, 10 s

5th torque part: 5 kNm, 43 s

Machine constant speed: 50 rpm

The equivalent power, which is required for gear unit selection, is to determine.

Solution:

Total time in a cycle;

$$t = t_1 + t_2 + t_3 + t_4 + t_5 = 120 \text{ sn}$$

Equivalent Torque;

$$T_e = \left(\frac{30 \times 48^{6.6} + \dots + 43 \times 5^{6.6}}{120} \right)^{\frac{1}{6.6}}$$
$$= 39,2 \text{ kNm}$$

50% of Equivalent torque;

$$0.5 \times T_e = 19.6 \text{ kNm}$$

Every torque part must be lower then this value;

$$T_4, T_5 < 0.5 \times T_e$$

We are repeating the calculation by taking out the torque parts, which are below 50%;

$$t' = t - t_4 - t_5 = 120 - 43 - 10 = 67 \text{ s}$$

$$T_e = \left(\frac{30 \times 48^{6.6} + \dots + 15 \times 28^{6.6}}{67} \right)^{\frac{1}{6.6}}$$
$$= 42,9 \text{ kNm}$$

By using the equivalent torque and constant speed we calculate the equivalent power ;

$$P_{eq} = \frac{T_e \times n}{9550} = \frac{42,9 \times 1000 \times 50}{9550} \cong 225 \text{ kW}$$

Now by using the above calculated equivalent power and constant speed we can make the gearbox selection with the procedures described in this catalogue.

Beispiel für Äquivalente Leistung

Die nachfolgenden Angaben sind für eine Blechreversierwalze;

Drehmoment stufen:

Gesamte Zeit für einem Arbeitszyklus: 2 min.

Drehmomentanteil 1: 48 kNm 30 s

Drehmomentanteil 2: 32 kNm 22 s

Drehmomentanteil 3: 28 kNm 15 s

Drehmomentanteil 4: 16 kNm 10 s

Drehmomentanteil 5: 5 kNm 43 s

Maschine hat konstante Drehzahl: 50 U/min

Gesucht ist die äquivalente Leistung, die für die Getriebeauslegung nötig ist.

Lösung:

Gesamte Zeit für einem Arbeitszyklus;

$$t = t_1 + t_2 + t_3 + t_4 + t_5 = 120 \text{ sn}$$

Äquivalentes Drehmoment;

$$T_e = \left(\frac{30 \times 48^{6.6} + \dots + 43 \times 5^{6.6}}{120} \right)^{\frac{1}{6.6}}$$
$$= 39,2 \text{ kNm}$$

50% von äquivalenten Drehmoment;

$$0.5 \times T_e = 19.6 \text{ kNm}$$

Drehmomentanteile müssen größer als dieser Wert sein;

$$T_4, T_5 < 0.5 \times T_e$$

Wir wiederholen die Berechnung nochmals ohne die kleine Drehmomentanteile;

$$t' = t - t_4 - t_5 = 120 - 43 - 10 = 67 \text{ s}$$

$$T_e = \left(\frac{30 \times 48^{6.6} + \dots + 15 \times 28^{6.6}}{67} \right)^{\frac{1}{6.6}}$$
$$= 42,9 \text{ kNm}$$

Mit Hilfe von äquivalenten Drehmoment und konstanter Drehzahl berechnet man die äquivalente Leistung ;

$$P_{eq} = \frac{T_e \times n}{9550} = \frac{42,9 \times 1000 \times 50}{9550} \cong 225 \text{ kW}$$

Nach Bestimmung der äquivalente Leistung und konstanter Drehzahl, erfolgt die Getriebeauslegung dann wie die Getriebeauswahl gemäß dem in diesem Katalog beschriebenen Verfahren für konstante Leistung.



Genel Bilgiler

General Information

Einführung



Redüktör Seçimi

Bir redüktör seçiminde aşağıdaki yol izlenmelidir.

1. Çalışma şartlarına bağlı olarak servis faktörünü (fs) belirleyiniz. (Servis Faktörü Sayfa 16).
2. Makinanız için gerekli olan momenti belirleyiniz M_2 (redüktör gerekli çıkış momenti).
3. Makinanızın devrini belirleyiniz n_2 (redüktör gerekli çıkış devri).
4. Makinanızın güç ihtiyacını (Redüktör çıkış gücünü) " P_2 " hesaplayınız.

$$P_2 = \frac{M_2 \times n_2}{9550}$$

5. Redüktör ile makina arasında kullanılan bağlantı elemanına göre radyal yükü hesaplayınız. (Sayfa 20). Yukarıdaki verilere uygun olarak çıkış devri, değerlerine uyan servis faktörü ve radyal yükü bulduğunuzdan daha yüksek veya eşit olan redüktörü, güç-devir seçim tablolarından seçiniz. Helisel tip redüktörlerde verim yüksek olduğundan çıkış gücü verilmemiştir. Hesapladığınız güç değerini giriş gücü olarak kabul edip seçiminizi yapınız. Tablolarda verilen M_2 çıkış momentinin hesapladığınız M_2 den büyük olmasına dikkat ediniz. Eğer seçilen redüktörünki daha ufak ise bir üst motor gücüne geçiniz.

Örnek

1. Makina Cinsi:

Lastik bantlı konveyör , dökme yük taşıyor.

2. Makina için gerekli moment:

Makina için hesaplanan moment $M_2 = 470 \text{ Nm}$.

3. Makina gerekli çıkış devri:

$n_2 = 50 \text{ dev/dak}$.

4. Günlük çalışma süresi:

16 saat.

5. Saatte start sayısı:

Saatte 1 start

6. Makina ile bağlantı şekli:

Zincir dişli (çap -160 mm)

- Yük sınıflandırma tablosundan yük sınıfı M olarak seçilir (sayfa 17-18)

- Günlük çalışma süresi 16 saat Saatte start sayısı 1 ve yük sınıfı M'ye tekabül eden servis faktörü tablosundan, servis faktörü için $fs = 1.3$ değeri bulunur.(sayfa 16)

- Makinanızın güç ihtiyacı (Redüktör Çıkış Gücü) :

$$P_2 = \frac{M_2 \times n_2}{9550} = \frac{470 \times 50}{9550} = 2,46 \text{ kW}$$

Gearbox Selection

For the correct selection of the appropriate gear units follow this steps.

1. Determine service factor (fs) on the basis of running conditions (Page 16).
2. Determine the required Torque M_2 (required output torque of gearbox) for the driven machine.
3. Determine required speed (output speed of gearbox) for the driven machine.
4. Calculate the required power for your machine (Calculate power " P_2 " required at output side of gear reducer using the formula);

$$P_2 = \frac{M_2 \times n_2}{9550}$$

5. Calculate overhung load required at output shaft according to type of connection between gear unit and machine (Refer to directions and values given on page 20). After determining the above mentioned values, the gear reducer which corresponds to our requirements can be selected from the performance tables (the service factor and the permissible overhung load should be less than or equal to our requirement). For Helical gears the output power is not given on the performance tables because they have high efficiency and the output power can be taken as input power. The output torque should be checked if it meets to our requirements. If the output torque is low, search for a higher input power gearbox.

Example:

1. Machine Type:

Belt Conveyor (Bulk Load)

2. Required Torque:

Required Torque calculated for the driven machine is $M_2 = 470 \text{ Nm}$.

3. Required speed:

$n_2 = 50 \text{ rpm}$

4. Running time:

16 hours per day

5. Frequency of starting:

1 start per hour

6. Connection type between gear reducer

Chain drive (output dimension-160 mm)

- From the load classification table (on page 17-18), the load class M can be selected for the known application.

- The service factor can be selected as $fs = 1,3$ from the service factor table (page 16) by taking into consideration 16 hours running time, one start per hour, and load class M.

- Required power for your machine (Power at output side of gear reducer) :

$$P_2 = \frac{M_2 \times n_2}{9550} = \frac{470 \times 50}{9550} = 2,46 \text{ kW}$$

Getriebeauswahl

Für die korrekte Auswahl des Antriebes;

1. Den Betriebsfaktor(fs) in Abhängigkeit von den Betriebsbedingungen bestimmen.(Bezug auf Seite 16).
2. Die erforderte Drehmoment M_2 für die angetriebene Maschine (Abtriebsdrehmoment für die Getriebe) bestimmen.
3. Erforderte Drehzahl bestimmen (Abtriebsdrehzahl für die Getriebe).
4. Berechnen der erforderte Leistung der angetriebene Maschine (Die an der Abtriebswelle erforderte Leistung " P_2 ") mit der unten angegebenen Formel.

$$P_2 = \frac{M_2 \times n_2}{9550}$$

5. Die an der Getriebeabtriebswelle erforderte Querkraft in Abhängigkeit von Antriebsselement bestimmen (Bezug auf Seite 20). Nach Bestimmen der oben angegebenen Werte, die passende Getriebe kann von den angegebenen Leistungstabellen entnommen werden. Dabei soll darauf geachtet werden, dass der Betriebsfaktor und Querkraft stets unterhalb von angegebenen Werten liegt. Weil Stirnradgetrieben einen hohen Wirkungsgrad haben, sind die Abtriebsleistungen für Stirnradgetrieben nicht angegeben. Bei dieser Getrieben die erforderte Leistung kann als Antriebsleistung benutzt werden. Achten sie darauf, dass der Abtriebsmoment größer als die erforderte Drehmoment ist.

Beispiel:

1. Maschinentyp:

Gurtbandförderer (Schüttgut)

2. Erforderte Drehmoment:

Für die Maschine berechnete Drehmoment $M_2 = 470 \text{ Nm}$.

3. Erforderte Drehzahl:

$n_2 = 50 \text{ upm}$

4. Betriebsdauer:

16 stunden pro Tag

5. Schalthäufigkeit:

1 Start pro Stunde

6. Antriebselement für verbindung

Getriebe-Machine:Kettentrieb(Durchmesser-160 mm)

- Von den Belastungsart Tabellen(Seite 17-18) nimmt man Belastungsart M

- Für den Schaltungszahl 1 und die Laufzeit16 und für den passenden Belastungsart erhält man Betriebsfaktor $fs = 1,3$ von Tabelle auf Seite 16.

- Erforderte Leistung der angetriebe Maschine (Die an der Getriebeabtriebswelle erforderte Leistung)

$$P_2 = \frac{M_2 \times n_2}{9550} = \frac{470 \times 50}{9550} = 2,46 \text{ kW}$$



Genel Bilgiler General Information Einführung



- Zincir dişli uygulaması için (Sayfa 21) F_q değeri;

$$F_q = \frac{2100 \times M_2}{D} = \frac{2100 \times 470}{180} = 5484 \text{ N}$$

- Ortaya çıkan redüktör ihtiyacı

$$\begin{aligned} P_2 &\geq 2,46 \text{ kW} \\ M_2 &\geq 470 \text{ Nm} \\ fs &\geq 1,3 \\ n_2 &= 50 \text{ d/dak} \\ F_q &\geq 5484 \text{ N} \end{aligned}$$

Güç ve devir sayılarından,

MR373-100L/4a seçilir. (Sayfa 81)

$$\begin{aligned} P_2 &= 3 \text{ kW} > 2,46 \text{ kW} \\ M_2 &= 573 \text{ Nm} > 470 \text{ Nm} \\ fs &= 1,3 \\ n_2 &= 47 \text{ d/dak} \\ F_{qam} &= 6616 \text{ N} > 5484 \text{ N} \end{aligned}$$

- *For chain drive application the requested overhang load can be calculated from (page 21).*

$$F_q = \frac{2100 \times M_2}{D} = \frac{2100 \times 470}{180} = 5484 \text{ N}$$

- *The required gearbox is as follows:*

$$\begin{aligned} P_2 &\geq 2,46 \text{ kW} \\ M_2 &\geq 470 \text{ Nm} \\ fs &\geq 1,3 \\ n_2 &= 50 \text{ rpm} \\ F_q &\geq 5484 \text{ N} \end{aligned}$$

From the performance table,

MR373-100L/4a selected. (Page 81)

$$\begin{aligned} P_2 &= 3 \text{ kW} > 2,46 \text{ kW} \\ M_2 &= 573 \text{ Nm} > 470 \text{ Nm} \\ fs &= 1,3 \\ n_2 &= 47 \text{ rpm} \\ F_{qam} &= 6616 \text{ N} > 5484 \text{ N} \end{aligned}$$

- Für Kettentrieb die erforderte Querkraft (seite 21).

$$F_q = \frac{2100 \times M_2}{D} = \frac{2100 \times 470}{180} = 5484 \text{ N}$$

- Von den oben angegebenen Berechnungen die erforderte Getriebe ist wie folgt;

$$\begin{aligned} P_2 &\geq 2,46 \text{ kW} \\ M_2 &\geq 470 \text{ Nm} \\ fs &\geq 1,3 \\ n_2 &= 50 \text{ U/min} \\ F_q &\geq 5484 \text{ N} \end{aligned}$$

Von der Leistung- DrehzahlTabelle ,

wurde **MR373-100L/4a** gewählt. (Seite 81)

$$\begin{aligned} P_2 &= 3 \text{ kW} > 2,46 \text{ kW} \\ M_2 &= 573 \text{ Nm} > 470 \text{ Nm} \\ fs &= 1,3 \\ n_2 &= 47 \text{ U/min} \\ F_{qam} &= 6616 \text{ N} > 5484 \text{ N} \end{aligned}$$



Genel Bilgiler

General Information

Einführung



Redüktör Seçim Formu

Kullanıldığı Sektör.....
Kullanıldığı Yer.....
Gerekli Ortalama Devir.....d/dak

Makina ihtiyaç gücü:

-Normal..... kW
-En çok..... kW
-En az..... kW

Tahrik Şekli:

AC Motor []
AC Motor + Invertör []
DC Motor []
Hidromotor []
1-3 silindri içten yanmalı []
2-4 silindri içten yanmalı []

Motor Bağlantı Şekli (Elektrik Motorları):

IEC B5 Flanşlı []
NEMA Flanşlı []
B3 Ayaklı []

IEC veya NEMA flanş kodu.

Motor Gücü:

-Nominal..... kW

Motor Devri:

-Normal..... d/dak
-En çok..... d/dak
-En az..... d/dak

Motor Torku:

-Normal..... Nm
-En çok..... Nm
-En az..... Nm

Dönüş şekli:

saat yönü [] saat yönüne ters [] değişken []

Günlük çalışma süresi:

<4 [] 4-8 [] 8-16 [] >16 []

Saatteki start sayısı:

0-50 [] 50-100 [] 100-200 []
200-300 [] 300-500 [] 500-700 []
700-1000 [] >1000 []

Motor Redüktör Arası Tahvil Oranı.....

Kalkış için gerekli moment.....Nm

Saatteki pik moment adedi:

1-5 [] 6-30 [] 31-100 [] >100 []

Bir çevrimde aktif çalışma oranı (ED):

%100 [] %80 [] %60 [] 40% [] %20 []

Deniz seviyesinden yükseklik:

<1000 [] <2000 [] <3000 []
<4000 [] <5000 []

Montaj yeri:

Küçük kapalı oda (w<1m/sn) []
Kapalı oda (w<3m/sn) []
Büyük oda ve holler (w>=3m/sn) []
Tamamen açık ortam []

Çevre Şartları:

Normal [] Tozlu [] Nemli []
Korozif [] Kuru []

Çevre Sıcaklığı:

Ortalama..... °C
En Yüksek..... °C
En Düşük..... °C

Kilit İhtiyacı:

Var [] Yok []

Redüktör Giriş Opsiyonu:

R.. [] V.. [] N.. [] T.. []

Montaj Pozisyonu:

M1 [] M2 [] M3 [] M4 [] M5 [] M6 []

Giriş mili bağlantı şekli:

Elastik kaplin []
Fıçı tipi kaplin []
Rijit kaplin []
Hidrolik Kaplin []
Kayış kasnak []
Zincir dişli []
Pinyon dişli []
Bağlantı elemanı çapı.....mm
Radyal yükü.....N
Radyal yük "u" mesafesi.....mm
Aksiyal yükü (mile doğru +).....N

Çıkış mili bağlantı şekli:

Elastik kaplin []
Fıçı tipi kaplin []
Rijit kaplin []
Kayış kasnak []
Zincir dişli []
Pinyon dişli []
Bağlantı elemanı çapı.....mm
Radyal yükü.....N
Radyal yük "u" mesafesi.....mm
Aksiyal yükü (mile doğru +).....N

Çıkış Mili Özelliği:

Dolu Mil Kamalı []
Dolu Mil Kamasız []
Özel Mil []

Giriş Mili Özelliği:

Kamalı []
Kamasız düz mil []
Özel Mil []

Elektrik Gerilimi:

AC-Monofaze [] AC-Trifaze [] DC []
Voltaj.....Volt
Frekans.....Hz

Koruma Sınıfı:

IP55 [] IP65 [] Exproof []
Diğer IP.....

Ekler:

Yük diyagramı []
Proje []
İstenen ana boyutlar []
Teknik veriler []

Diğer Notlar:



Genel Bilgiler

General Information

Einführung



Gearbox Selection Form

Field of Industry.....
 Application.....
 Required Average Speed..... rpm

Required Power on Driven Machine:

-Normal..... kW
 -Maximum..... kW
 -Minimum..... kW

Driving Machine:

AC Motor []
 AC Motor + Inverter []
 DC Motor []
 Hydraulic Motor []
 Piston Engine with 1-3 cylinder []
 Piston Engine with 4-24 cylinder []

Motor Connection Type (Electric Motors):

IEC B5 Flange []
 NEMA Flange []
 B3 Foot Mounted []

IEC or NEMA Flange Code.....

Motor Power:

-Nominal.....kW

Motor Speed:

-Normal.....rpm
 -Maximum.....rpm
 -Minimum.....rpm

Motor Torque:

-Normal.....Nm
 -Maximum.....Nm
 -Minimum.....Nm

Direction of Rotation:

cw [] ccw [] variable []

Working hours per day:

<4 [] 4-8 [] 8-16 [] >16 []

Startings per cycle:

0-50 [] 50-100 [] 100-200 []
 200-300 [] 300-500 [] 500-700 []
 700-1000 [] >1000 []

Transmission ratio between motor and gear unit.....

Required Starting Torque.....Nm

Peak torques per hour:

1-5 [] 6-30 [] 31-100 [] >100 []

Effective working time in a cycle (ED):

%100 [] %80 [] %60 [] 40% []
 20% []

Altitude:

<1000 [] <2000 [] <3000 []
 <4000 [] <5000 []

Mounting Place:

Small closed room (w<1m/sn) []
 Closed room (w<3m/sn) []
 Big rooms and halls (w>=3m/sn) []
 Outdoor []

Ambient Conditions:

Normal [] Dusty [] Humid []
 Corrosive [] Dry []

Ambient Temperature:

Average.....°C
 Maximum.....°C
 Minimum.....°C

Backstop Required:

Yes [] No []

Gearbox input options:

R.. [] V.. [] N.. [] T.. []

Mounting Position:

M1 [] M2 [] M3 [] M4 [] M5 [] M6 []

Input Shaft Connection Type:

Elastic Coupling []
 Barrel Type Coupling []
 Hydraulic Coupling []
 Rigid Flange Coupling []
 Pulley []
 Chain Sprocket []
 Pinion []
 Diameter of Connection element.....mm
 Radial Load.....N
 "u" Distance of Radial Load.....mm
 Axial Load (Towards Shaft)N

Output Shaft Connection Type:

Elastic Coupling []
 Barrel Type Coupling []
 Rigid Flange Coupling []
 Pulley []
 Chain Sprocket []
 Pinion []
 Diameter of Connection Element.....mm
 Radial Load.....N
 "u" Distance of Radial Load.....mm
 Axial Load (Towards Shaft)N

Output Shaft Specification:

Solid Shaft with Keyway []
 Solid Shaft without Keyway []
 Special Shaft []

Input Shaft Specification:

Solid Shaft with Keyway []
 Solid Shaft without Keyway []
 Special Shaft []

Electrical Supply:

AC-1 Phase [] AC-3 Phase [] DC []
 Voltage.....Volt
 Frequency..... Hz

Protection Class:

IP55 [] IP65 [] Exproof []
 Other IP.....

Attachments:

Load Diagram []
 Project []
 Required Dimensions []
 Technical Specifications []

Notes:

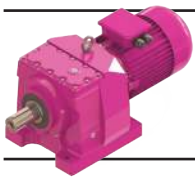

Genel Bilgiler

General Information

Einführung



Formular für Getriebeauswahl

Industriebereich.....
 Anwendung.....
 Erforderliche Drehzahl.....U/min

Erforderliche Leistung für die Maschine:

-Normal.....kW
 -Minimal.....kW
 -Maximal.....kW

Antriebsmaschine:

AC Motor []
 AC Motor mit Frequenzumrichter []
 DC Motor []
 Hydromotor []
 Kolbenmaschinen mit 1-3 Zylinder []
 Kolbenmaschinen mit 2-4 Zylinder []

Motorverbindungsart (Elektromotoren):

IEC B5 Flansch []
 NEMA Flansch []
 B3 Fussausführung []

IEC oder NEMA Flanschcode.....

Motorleistung:

-Nominal.....kW

Motordrehzahl:

-Normal.....U/min
 -Maximal.....U/min
 -Minimal.....U/min

Motordrehmoment:

-Normal.....Nm
 -Maximal.....Nm
 -Minimal.....Nm

Drehrichtung:

in Uhrzeigersinn [] gegen Uhrzeigersinn []
 veränderlich []

Betriebsdauer in Stunden pro Tag:

<4 [] 4-8 [] 8-16 [] >16 []

Anzahl der Anläufe pro Stunde:

0-50 [] 50-100 [] 100-200 []
 200-300 [] 300-500 [] 500-700 []
 700-1000 [] >1000 []

Übersetzung zwischen Motor und Antriebs-
 welle.....

Erforderliches Anlaufmoment.....Nm

Häufigkeit von Lastspitzen pro Stunde:

1-5 [] 6-30 [] 31-100 [] >100 []

Einschaltdauer je Stunde (ED):

%100 [] %80 [] %60 [] 40% [] %20 []

Höhenlage über Meeresspiegel (m):

<1000 [] <2000 [] <3000 []
 <4000 [] <5000 []

Betriebsort:

Kleine geschlossene Räume (w<1m/sn) []
 Geschlossene Räume (w<3m/sn) []
 Große Räume und Hallen (w>=3m/sn) []
 im Freien []

Umgebungsbedingungen:

Normal [] Staubig [] Feucht []
 Korrodierend [] Trocken [] Verklebend []

Umgebungstemperatur:

Mittelwert.....°C
 Maximal.....°C
 Minimal.....°C

Rücklaufsperre erforderlich:

Ja [] Nein []

Getriebeeingangsvarianten:

R.. [] V.. [] N.. [] T.. []

Montageposition:

M1 [] M2 [] M3 [] M4 [] M5 [] M6 []

Antriebswellenanschluss:

Elastische Kupplung []
 Trommelkupplung []
 Hydrokupplung []
 Starre Flanschkupplung []
 Keilriementrieb []
 Kettenrad []
 Ritzel []
 Durchmesser von Anschlusselement.....mm
 Querkraft.....N
 "u" Abstand von der Wellenschulter.....mm
 Axialkraft (in Richtung der Welle +)N

Abtriebswellenanschluss:

Elastische Kupplung []
 Trommelkupplung []
 Starre Flanschkupplung []
 Keilriementrieb []
 Kettenrad []
 Ritzel []
 Durchmesser von Anschlusselement.....mm
 Querkraft.....N
 "u" Abstand von der Wellenschulter.....mm
 Axialkraft (in Richtung der Welle +)N

Eigenschaften der Abtriebswelle:

Vollwelle mit Passfeder []
 Vollwelle ohne Passfeder []
 Sonderwelle []

Eigenschaften der Antriebswelle:

Vollwelle mit Paßfeder []
 Vollwelle ohne Paßfeder []
 Sonderwelle []

Spannungsversorgung:

AC-1 phasig [] AC-3 phasig [] DC []
 Spannung.....Volt
 Frequenz.....Hz

Schutzart:

IP55 [] IP65 [] Exproof []
 Andere IP.....



Genel Bilgiler

General Information

Einführung



Yağlama

Redüktörlerin uzun ömürlü olması ve iyi performansla çalışabilmesi için, kullanılan yağın seçimi doğru olmalı ve belirtilen zamanlarda değişimleri yapılmalıdır.

Yağın seçiminde devir, çevre sıcaklığı, re-düktör yağ sıcaklığı, çalışma koşulları ve yağ ömrü önem taşımaktadır. Redüktörler yağı doldurulmuş olarak sevkedilmektedir. Redüktörler uzun süre depolanacakları zaman veya çalışmaya başlanacağı zaman çalışma konumuna göre üstte kalan tapa sökülmeli ve re-düktörün beraberinde verilen havalandırma tapanı kullanılmalıdır. Bu re-düktörün iç basıncından dolayı oluşacak yağ sızmalarını önleyecektir.

Redüktörlerde standart olarak kullanılan yağlar yan sayfadaki tabloda verilmiştir. Redüktörünüzde kullanılan yağ tipi için lütfen etiketine bakınız. Siparişte belirtilmez ise M serisi re-düktörler **M1** ve N serisi re-düktörler **M4** pozisyonuna göre yağ miktarları ile doldurulur. Bu pozisyonlar dışındaki çalışma durumlarında tablolarda verilen yağ miktarlarına göre ilave veya eksiltme yapılmalıdır. Özel çalışma koşullarında firmamızla danışmanız tavsiye edilir.

Mineral yağlar her 10.000 çalışma saatinde, sentetik yağlar ise her 20.000 çalışma saatinde değiştirilmelidir. Ağır çevre koşullarında (ani ısı değişiklikleri, yüksek nemlilik v.b) yağ değiştirme periyotlarının kısaltılması tavsiye edilir. Mineral yağlar ile sentetik yağlar birbirine kesinlikle karıştırılmamalıdır. Değişirme işlemi bir çalışma periyodunun hemen peşinden ve yağ sıcakken yapılmalıdır. Bu şekilde bir değişirme, re-düktör içindeki partiküllerin yağa karışmış olarak bulunmasından dolayı iyi bir temizleme ve yağın rahat boşalması neticesini verecektir.

Lubrication

To work in perfect condition and to have long life for the gear box the lubricant must be chosen correctly and changed in time.

In selection of oil it is important to consider speed, ambient temperature, gear box oil temperature, working conditions and the life required from the lubricant. All units are filled with lubricant before shipping. Before the gearbox is stored for a long time or before starting up, the top plug (according to the working position) must be removed and the extra given vent plug must be replaced. This prevents excessive pressure which causes oil leakages.

*The lubricants for standard gear units are given on the table on next page. Please look at your gear units label for filled oil type. If it is not written on the gearbox selection form, the M type gearboxes are filled for mounting position of **M1** and N type gearboxes are filled for mounting position **M4**. For other mounting positions please refer to the table given on the next pages. For special working conditions please contact us.*

The mineral lubricant should be changed after every 10.000 service hours and the synthetic lubricant should be changed after every 20.000 working hours. If the operation conditions are very heavy (e.g. high temperature differences, high humidity) shorter intervals between changes are recommended. Mineral and synthetic oils must not be mixed up. By changing the lubricant complete cleaning is advised. The oil change should be done after a working period. Because oil is hot in this condition and impurities are mixed with it the changing of oil will be done in best result and the oil will drain easily.

Schmierung

Um eine lange Lebensdauer zu gewährleisten muss der Schmierstoff richtig ausgewählt werden.

Für die richtige Ölauswahl müssen Drehzahl, Umgebungs-temperatur, Belastungsart und Lebensdauer des Öls berücksichtigt werden. Die mitgelieferte Entlüftungsschraube ist vor Inbetriebnahme oder längeren Lagern gegen die Einfüllschraube auszutauschen, um einen Überdruck im Getriebe und damit eine Undichtigkeit des Getriebes zu vermeiden. Getriebe und Getriebemotoren sind bei Auslieferung betriebsfertig gefüllt.

Ohne besondere Bestellangaben werden die Getriebe grundsätzlich mit den auf der folgenden Seite in der grau unterlegten Spalte angegebenen Schmierstoffen gefüllt. Bitte im Getriebe verwendetes Öl von dem Namensschild ablesen. Die fußbefestigten Getriebe (M Serie) sind gefüllt für Bauform **M1** und die flanschbefestigten Getriebe (N Serie) für Bauform **M4**, wenn bei der Bestellung keine Angaben vorgegeben sind. Für andere Bauformen sind die auf der nächsten Seite angegebenen Füllmengen zu beachten.

Ein Schmierstoffwechsel sollte alle 10.000 Betriebsstunden durchgeführt werden. Für synthetische Produkte verdoppeln sich diese Fristen. Bei extremen Betriebsbedingungen, z.B. hohe Luftfeuchtigkeit, aggressiver Umgebung und hohen Temperatur-schwankungen sind kürzere Schmierstoffintervalle vorteilhaft. Es ist empfehlenswert, dem Schmierstoffwechsel mit einer gründlichen Reinigung des Getriebes zu verbinden. Synthetische und mineralische Schmierstoffe dürfen nicht miteinander vermischt werden. Das Ablassen des Öls soll unmittelbar nach dem Abschalten erfolgen, solange das Öl noch warm ist. In dieser Zustand ist das Öl mit den Schmutzpartikeln vermischt, so dass eine Entfernung des Altöls eine gute Reinigung benötigt.



Genel Bilgiler

General Information

Einführung



Yağ Tipleri / Oil Types / Schmierstoffe

Yağ Cinsi Lubricant Art des Schmier- stoffes	DIN 51517-3	Çevre Sıcaklığı [°C] Ambient Temp. [°C] Umgebungstemp. [°C]	ISO VG	Aral	Beyond Petroleum	Castrol	Klüber Lubrication	Mobil	Shell	Total
		Daldırma Yağlama Dip Lubrication Tauchschmierung								
Mineral Yağlar Mineral Oil Mineralöl	CLP	0 ... +50	680	Degol BG 680	Energol GR-XP 680	Alpha SP 680	Klüberoil GEM 1-680 N	Mobilgear XMP 680	Omala 680	Carter EP 680
		-5 ... +45	460	Degol BG 460	Energol GR-XP 460	Alpha SP 460	Klüberoil GEM 1-460 N	Mobilgear XMP 460	Omala F460	Carter EP 460
		-10 ... +40	320	Degol BG 320	Energol GR-XP 320	Alpha SP 320	Klüberoil GEM 1-320 N	Mobilgear XMP 320	Omala F320	Carter EP 320
		-15 ... +30	220	Degol BG 220	Energol GR-XP 220	Alpha SP 220	Klüberoil GEM 1-220 N	Mobilgear XMP 220	Omala F220	Carter EP 220
		-20 ... +20	150	Degol BG 150	Energol GR-XP 150	Alpha SP 150	Klüberoil GEM 1-150 N	Mobilgear XMP 150	Omala 150	Carter EP 150
		-25... +10	100	Degol BG 100	Energol GR-XP 100	Alpha SP 100	Klüberoil GEM 1-100 N	Mobilgear XMP 100	Omala 100	Carter EP 100
Sentetik Yağlar Synthetic Oil Synthetisches Öl	CLP PG	-10 ... +60	680	Degol GS 680	Energol SG-XP 680	-	Klübersynth GH 6 -680	Mobil Glygoyle 680	Tivela S 680	Carter SY 680
		-20 ... +50	460	Degol GS 460	Energol SG-XP 460	Aphasyn PG 460	Klübersynth GH 6 -460	Mobil Glygoyle 460	Tivela S 460	Carter SY 460
		-25 ... +40	320	Degol GS 320	Energol SG-XP 320	Aphasyn PG 320	Klübersynth GH 6 -320	Mobil Glygoyle 320	Tivela S 320	Carter SY 320
		-30 ... +30	220	Degol GS 220	Energol SG-XP 220	Aphasyn PG 220	Klübersynth GH 6 -220	Mobil Glygoyle 30	Tivela S 220	Carter SY 220
		-35 ... +20	150	Degol GS 150	Energol SG-XP 150	Aphasyn PG 150	Klübersynth GH 6 -150	Mobil Glygoyle 22	Tivela S 150	Carter SY 150
		-40 ... +10	100	-	-	-	Klübersynth GH 6 -100	Mobil Glygoyle 100	-	-
	CLP HC	-10 ... +60	680	-	-	-	Klübersynth GEM 4-680 N	Mobil SHC Gear 680	-	Carter SH 680
		-20 ... +50	460	Degol PAS 460	Energol EP-XF 460	Alphasyn T 460	Klübersynth GEM 4-460 N	Mobil SHC Gear 460	Omala HD 460	Carter SH 460
		-25 ... +40	320	Degol PAS 320	Energol EP-XF 320	Alphasyn T 320	Klübersynth GEM 4-320 N	Mobil SHC Gear 320	Omala HD 320	Carter SH 320
		-30 ... +30	220	Degol PAS 220	Energol EP-XF 220	Alphasyn T 220	Klübersynth GEM 4-220 N	Mobil SHC Gear 220	Omala HD 220	Carter SH 220
		-35 ... +20	150	Degol PAS 150	Energol EP-XF 150	Alphasyn T 150	Klübersynth GEM 4-150 N	-	Omala HD 150	Carter SH 150
		-40 ... +10	100	-	-	-	Klübersynth GEM 4-100 N	-	-	-
Gıda Uyumlu Yağ Food Grade Oil Lebensmittelöl	CLP NSF H1	-15 ... +25	320	-	-	Optileb GT 320	Klüberoil 4 UH1-320 N	Mobil SHC Cibus 320	Cassida Fluid GL-320	Nevastane SL 320
Çevre Dostu Yağ Biodegradable Oil Biologisch abbaubares Öl	CLP E	-25 ... +40	320	-	-	Tribol BioTop 1418-320	Klübersynth GEM 2-320	-	-	Carter Bio 320
Mineral Gresler [-20 +130 Çalışma Sıcaklığı °C] Mineral Grease [-20 +130 Working Temperature °C] Mineral-Fett [-20 +130 Betriebstemperatur °C]				Aralub HL3	Energol LS 3	Spheerol AP3	Centoplex 2 EP	Mobilux EP 3	Alvania RL3	Multis Complex EP 2
Sentetik Gresler [-30 +130 Çalışma Sıcaklığı °C] Synthetic Grease [-30 +130 Working Temperature °C] Synthetisches Fett [-30 +130 Betriebstemperatur °C]				-	Energol SY 2202	-	Petamo GHY 133 N	Mobiltemp SHC 100	Cassida RLS 2	Multis Complex SHD 220



Genel Bilgiler

General Information

Einführung



Montaj Pozisyonları / Mounting Positions / Bauformen

M Serisi

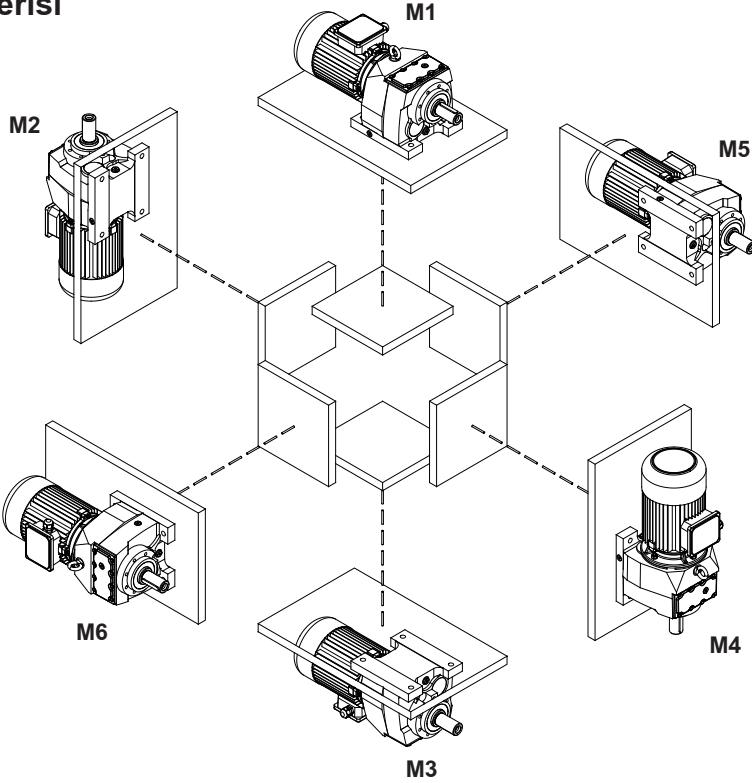

M1....M6 'ya kadar belirtilen montaj pozisyonları redüktörün duruş yönü referans alınarak belirlenmiştir. Montaj yüzeyleri bağlayıcı değildir.

Figured mounting positions of M1 to M6 are determined as reference of directional position of the gearbox. Mounting surfaces are not binding.

Dargestellte Montagepositionen M1 bis M6 wurden nach der Stehrichtung von Getriebe bestimmt. Montageoberflächen sind unverbindlich.

N Serisi

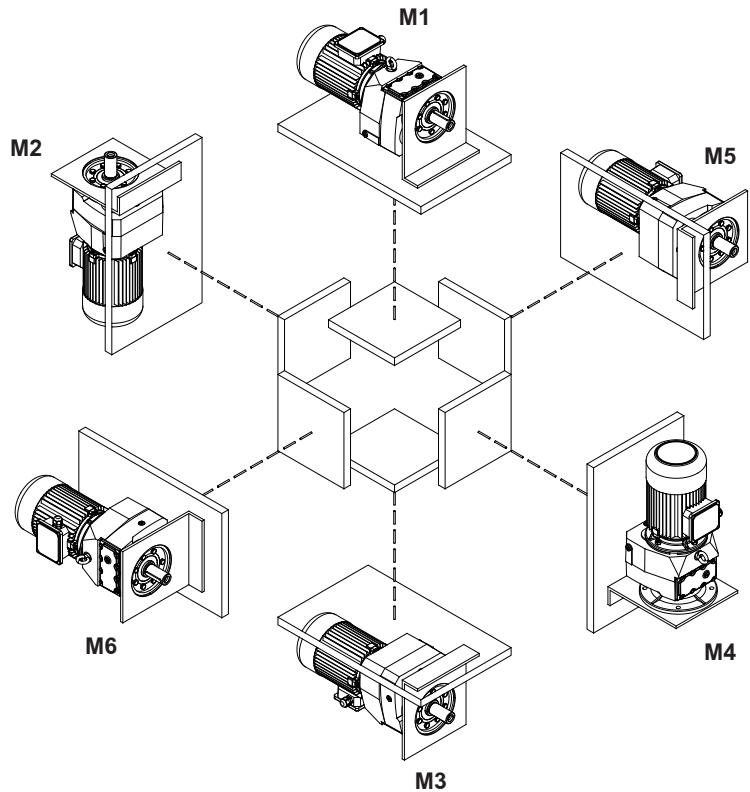

M1....M6 'ya kadar belirtilen montaj pozisyonları redüktörün duruş yönü referans alınarak belirlenmiştir. Montaj yüzeyleri bağlayıcı değildir.

Figured mounting positions of M1 to M6 are determined as reference of directional position of the gearbox. Mounting surfaces are not binding.

Dargestellte Montagepositionen M1 bis M6 wurden nach der Stehrichtung von Getriebe bestimmt. Montageoberflächen sind unverbindlich.



Genel Bilgiler

General Information

Einführung



M Serisi İki Üç Kademeli Helisel Dişli Redüktörler Yağ Seviye Tapaları

M Series Two -Three Stage Helical Gearboxes Oil Level Plugs

M Serie Zwei-Dreistufig Stirnradgetriebe Ölverschlußschrauben

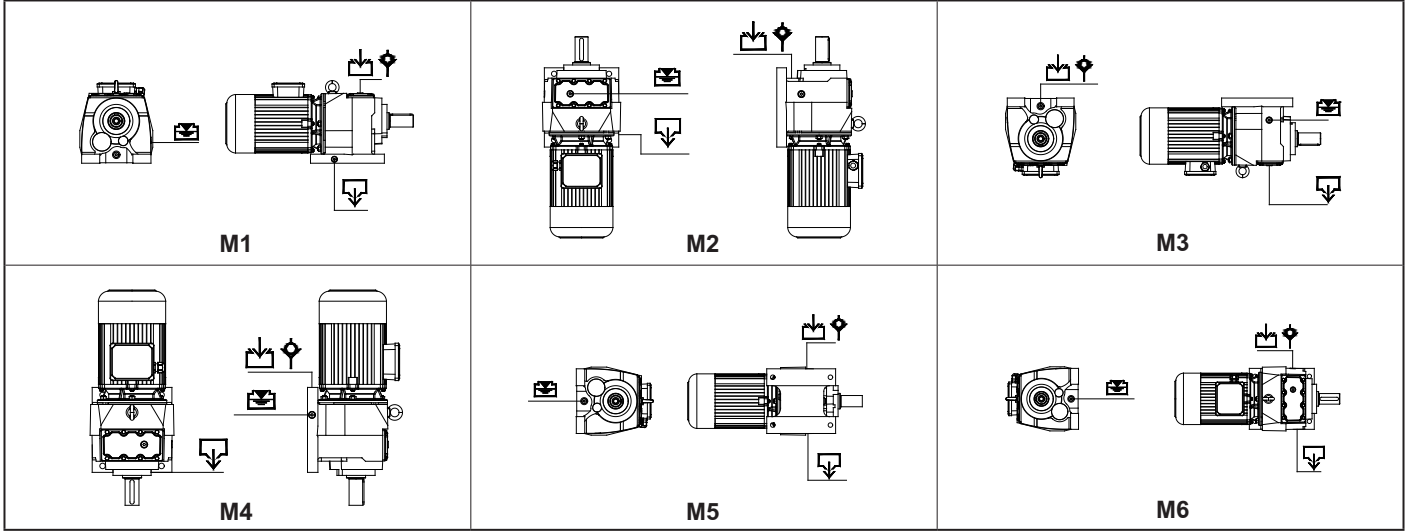

Yağ Miktarları (lt) / Oil Quantities (lt) / Ölmengen (lt)

Tip Type Typ	M Serisi 2-3 Kademe Yağ Miktarları M Series 2-3 Stages Oil Quantities Ölmengen von M Serie mit 2-3 Stufen					
	M1	M2	M3	M4	M5	M6
M002 / 003	0.4 / 0.35	0.6 / 0.55	0.5 / 0.5	0.6 / 0.55	0.5 / 0.4	0.5 / 0.4
M102 / 103	0.65 / 0.6	0.95 / 0.8	0.7 / 0.7	0.95 / 0.8	0.7 / 0.7	0.7 / 0.7
M172 / 173	0.7 / 0.65	0.95 / 0.9	0.8 / 0.8	0.95 / 0.9	0.8 / 0.7	0.8 / 0.7
M202 / 203	1.2 / 1.1	2.1 / 2	2 / 1.9	2.1 / 2	1.4 / 1.3	1.4 / 1.3
M272 / 273	1.1 / 1	2 / 1.7	1.9 / 1.5	2 / 1.7	1.3 / 1.2	1.3 / 1.2
M282 / 283	1.7 / 1.6	3 / 2.85	2.8 / 2.5	3 / 2.85	2.6 / 2.4	2.6 / 2.4
M372 / 373	2 / 1.9	3.4 / 3.3	3.1 / 3	3.4 / 3.3	2.8 / 2.6	2.8 / 2.6
M472 / 473	4.5 / 4	8 / 7.6	7.5 / 7	8 / 7.6	5.5 / 5	5.5 / 5
M572 / 573	7 / 6	12.8 / 11.7	11.5 / 10.5	12.8 / 11.7	8 / 7.5	8 / 7.5
M672 / 673	10 / 8.5	22.5 / 20	20 / 18	22.5 / 20	11 / 11	11 / 11
M772 / 773	20 / 18	35 / 32	30 / 28	35 / 32	22 / 20	22 / 20
M872 / 873	28 / 20	53 / 45	45 / 39	53 / 45	30 / 28	30 / 28
M972 / 973	53 / 50	90 / 87	82 / 80	90 / 87	70 / 65	70 / 65

Semboller :
Symbols :
Symbole :



:Yağ doldurma
:Oil filling
:Ölfüllung



:Yağ boşaltma
:Drain plug
:Ölauslass



:Yağ seviyesi
:Oil level
:Ölstand



:Havalandırma
:Vent Plug
:Entlüftungsschraube



Genel Bilgiler

General Information

Einführung



N Serisi İki Üç Kademeli Helisel Dişli Redüktörler Yağ Seviye Tapaları

N Series Two -Three Stage Helical Gearboxes Oil Level Plugs

N Serie Zwei-Dreistufig Stirnradgetriebe Ölverschlußschrauben

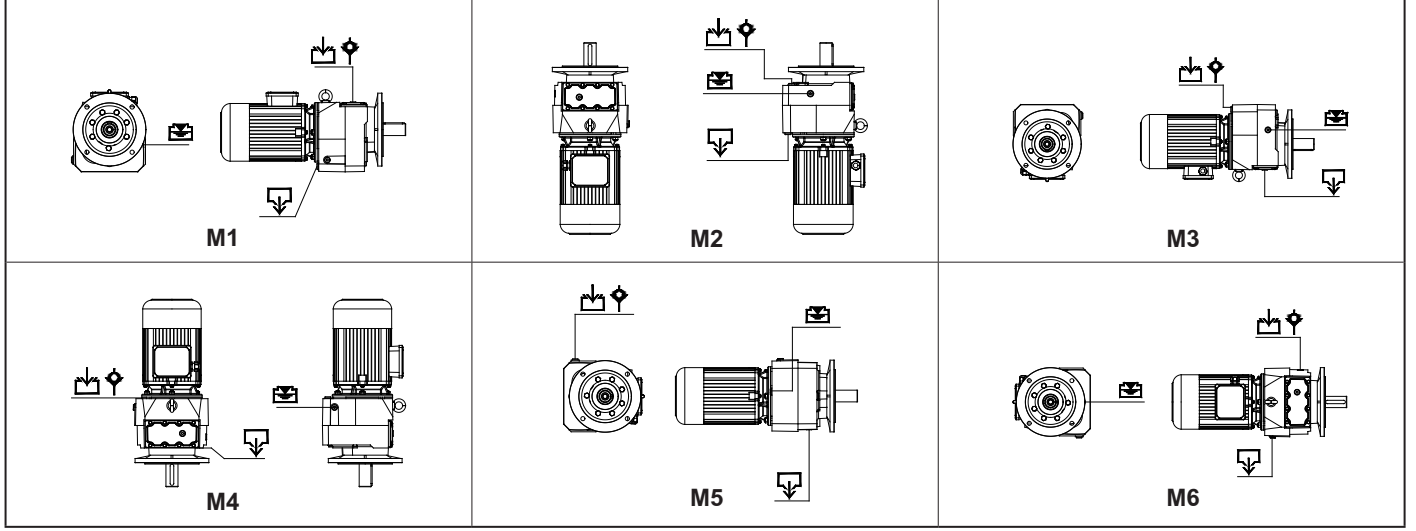

Yağ Miktarları (lt) / Oil Quantities (lt) / Ölmengen (lt)

Tip Type Typ	N Serisi 2-3 Kademe Yağ Miktarları N Series 2-3 Stages Oil Quantities Ölmengen von N Serie mit 2-3 Stufen					
	M1	M2	M3	M4	M5	M6
N002 / 003	0.4 / 0.35	0.6 / 0.55	0.5 / 0.5	0.6 / 0.55	0.5 / 0.4	0.5 / 0.4
N102 / 103	0.65 / 0.6	0.95 / 0.8	0.7 / 0.7	0.95 / 0.8	0.7 / 0.7	0.7 / 0.7
N172 / 173	0.7 / 0.65	0.95 / 0.9	0.8 / 0.8	0.95 / 0.9	0.8 / 0.7	0.8 / 0.7
N202 / 203	1.2 / 1.1	2.1 / 2	2 / 1.9	2.1 / 2	1.4 / 1.3	1.4 / 1.3
N272 / 273	1.1 / 1	2 / 1.7	1.9 / 1.5	2 / 1.7	1.3 / 1.2	1.3 / 1.2
N282 / 283	1.7 / 1.6	3 / 2.85	2.8 / 2.5	3 / 2.85	2.6 / 2.4	2.6 / 2.4
N372 / 373	2 / 1.9	3.4 / 3.3	3.1 / 3	3.4 / 3.3	2.8 / 2.6	2.8 / 2.6
N472 / 473	4.5 / 4	8 / 7.6	7.5 / 7	8 / 7.6	5.5 / 5	5.5 / 5
N572 / 573	7 / 6	12.8 / 11.7	11.5 / 10.5	12.8 / 11.7	8 / 7.5	8 / 7.5
N672 / 673	10 / 8.5	22.5 / 20	20 / 18	22.5 / 20	11 / 11	11 / 11
N772 / 773	20 / 18	35 / 32	30 / 28	35 / 32	22 / 20	22 / 20
N872 / 873	28 / 20	53 / 45	45 / 39	53 / 45	30 / 28	30 / 28
N972 / 973	53 / 50	90 / 87	82 / 80	90 / 87	70 / 65	70 / 65

Semboller :
Symbols :
Symbole :

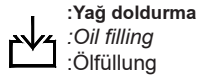

:Yağ doldurma
:Oil filling
:Ölfüllung

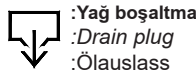

:Yağ boşaltma
:Drain plug
:Ölauslass

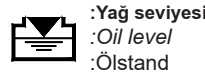

:Yağ seviyesi
:Oil level
:Ölstand



:Havalandırma
:Vent Plug
:Entlüftungsschraube



Genel Bilgiler

General Information

Einführung



M Serisi Dört Kademeli Helisel Dişli Redüktörler Yağ Seviye Tapaları

M Series Four Stage Helical Gearboxes Oil Level Plugs

M Serie Vierstufig Stirnradgetriebe mit Ölverschlußschrauben

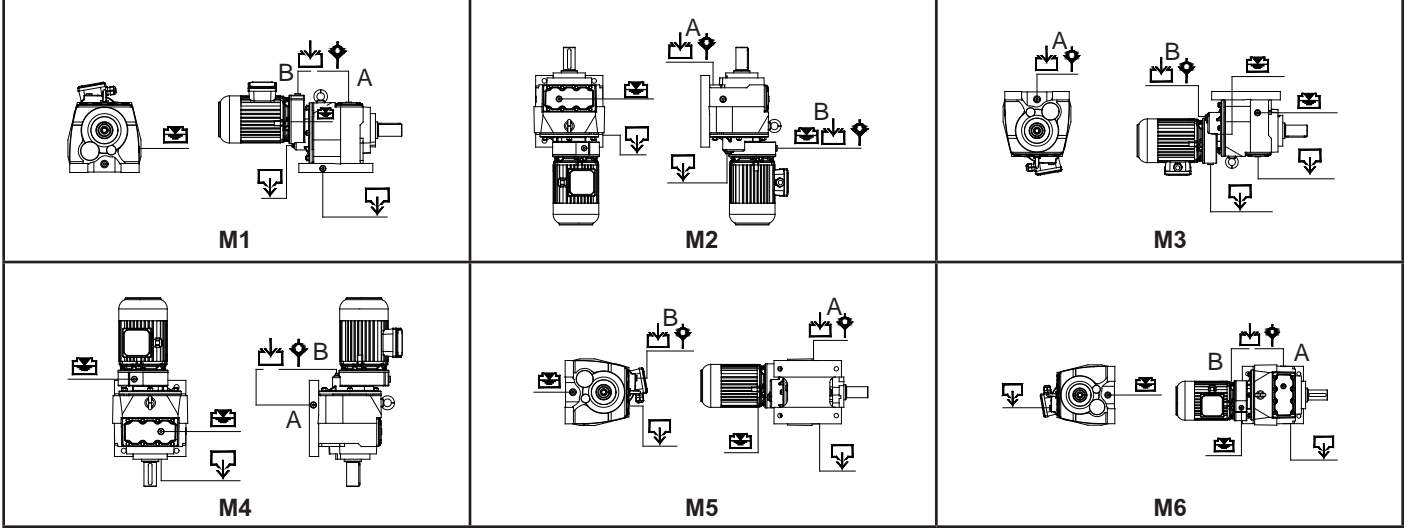

Yağ Miktarları (lt) / Oil Quantities (lt) / Ölmengen (lt)

Tip Type Typ	M Serisi 4 Kademe Yağ Miktarları M Series 4 Stages Oil Quantities Ölmengen von M Serie mit 4 Stufen					
	M1 A / B	M2 A / B	M3 A / B	M4 A / B	M5 A / B	M6 A / B
M284	1.6 / 0.25	2.85 / 0.25	2.5 / 0.25	2.85 / 0.25	2.4 / 0.25	2.4 / 0.25
M374	1.9 / 0.25	3.3 / 0.25	3 / 0.25	3.3 / 0.25	2.6 / 0.25	2.6 / 0.25
M474	4 / 0.4	7.6 / 0.4	7 / 0.4	7.6 / 0.4	5 / 0.4	5 / 0.4
M574	6 / 0.50	11.7 / 0.50	10.5 / 0.50	11.7 / 0.50	7.5 / 0.50	7.5 / 0.50
M674	8.5 / 0.90	20 / 0.90	18 / 0.90	20 / 0.90	11 / 0.90	10.5 / 0.90
M774	18 / 1	32 / 1	28 / 1	32 / 1	20 / 1	20 / 1
M874	20 / 2.15	45 / 2.15	39 / 2.15	45 / 2.15	28 / 2.15	28 / 2.15
M974	50 / 7	87 / 7	80 / 7	87 / 7	65 / 7	65 / 7

Semboller :
Symbols :
Symbole :



:Yağ doldurma
:Oil filling
:Ölfüllung



:Yağ boşaltma
:Drain plug
:Ölauslass



:Yağ seviyesi
:Oil level
:Ölstand



:Havalandırma
:Vent Plug
:Entlüftungsschraube



Genel Bilgiler

General Information

Einführung



N Serisi Dört Kademeli Helisel Dişli Redüktörler Yağ Seviye Tapaları

N Series Four Stage Helical Gearboxes Oil Level Plugs

N Serie Vierstufig Stirnradgetriebe mit Ölverschlußschrauben

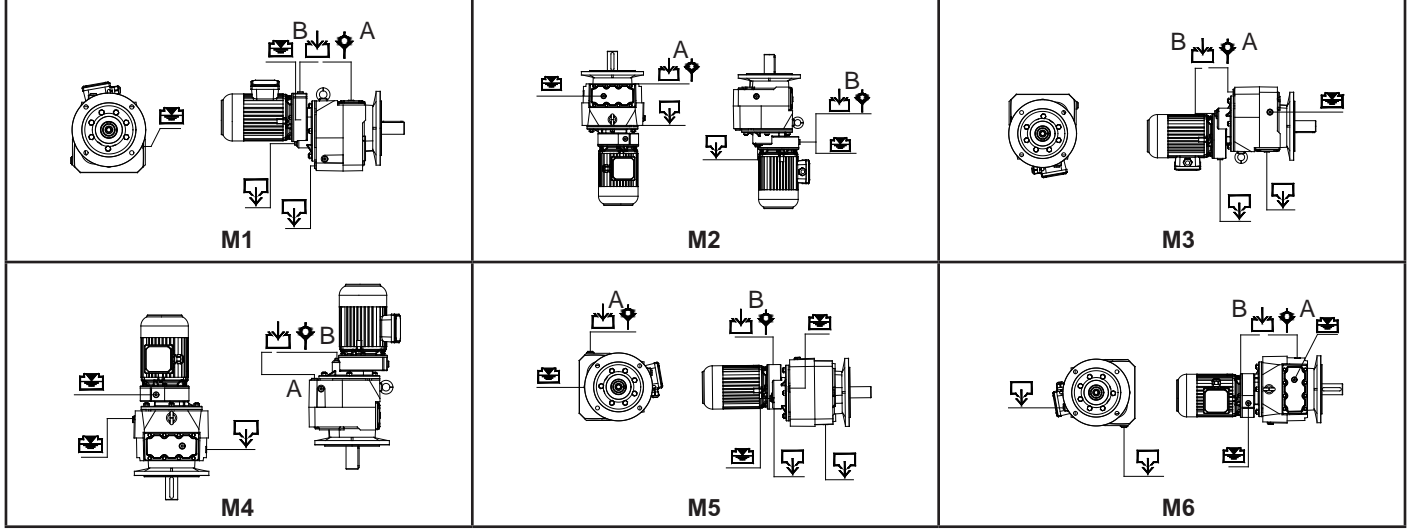

Yağ Miktarları (lt) / Oil Quantities (lt) / Ölmengen (lt)

Tip Type Typ	N Serisi 4 Kademe Yağ Miktarları N Series 4 Stages Oil Quantities Ölmengen von N Serie mit 4 Stufen					
	M1 A / B	M2 A / B	M3 A / B	M4 A / B	M5 A / B	M6 A / B
N284	1.6 / 0.25	2.85 / 0.25	2.5 / 0.25	2.85 / 0.25	2.4 / 0.25	2.4 / 0.25
N374	1.9 / 0.25	3.3 / 0.25	3 / 0.25	3.3 / 0.25	2.6 / 0.25	2.6 / 0.25
N474	4 / 0.4	7.6 / 0.4	7 / 0.4	7.6 / 0.4	5 / 0.4	5 / 0.4
N574	6 / 0.50	11.7 / 0.50	10.5 / 0.50	11.7 / 0.50	7.5 / 0.50	7.5 / 0.50
N674	8.5 / 0.90	20 / 0.90	18 / 0.90	20 / 0.90	11 / 0.90	10.5 / 0.90
N774	18 / 1	32 / 1	28 / 1	32 / 1	20 / 1	20 / 1
N874	20 / 2.15	45 / 2.15	39 / 2.15	45 / 2.15	28 / 2.15	28 / 2.15
N974	50 / 7	87 / 7	80 / 7	87 / 7	65 / 7	65 / 7

Semboller :

Symbols :

Symbole :



:Yağ doldurma

:Oil filling

:Ölfüllung



:Yağ boşaltma

:Drain plug

:Ölauslass



:Yağ seviyesi

:Oil level

:Ölstand



:Havalandırma

:Vent Plug

:Entlüftungsschraube



Genel Bilgiler

General Information

Einführung



M Serisi Beş-Altı Kademeli Helisel Dişli Redüktörler Yağ Seviye Tapaları

M Series Five-Six Stage Helical Gearboxes Oil Level Plugs

M Serie Fünf-Sechsstufig Stirnradgetriebe Ölverschlußschrauben

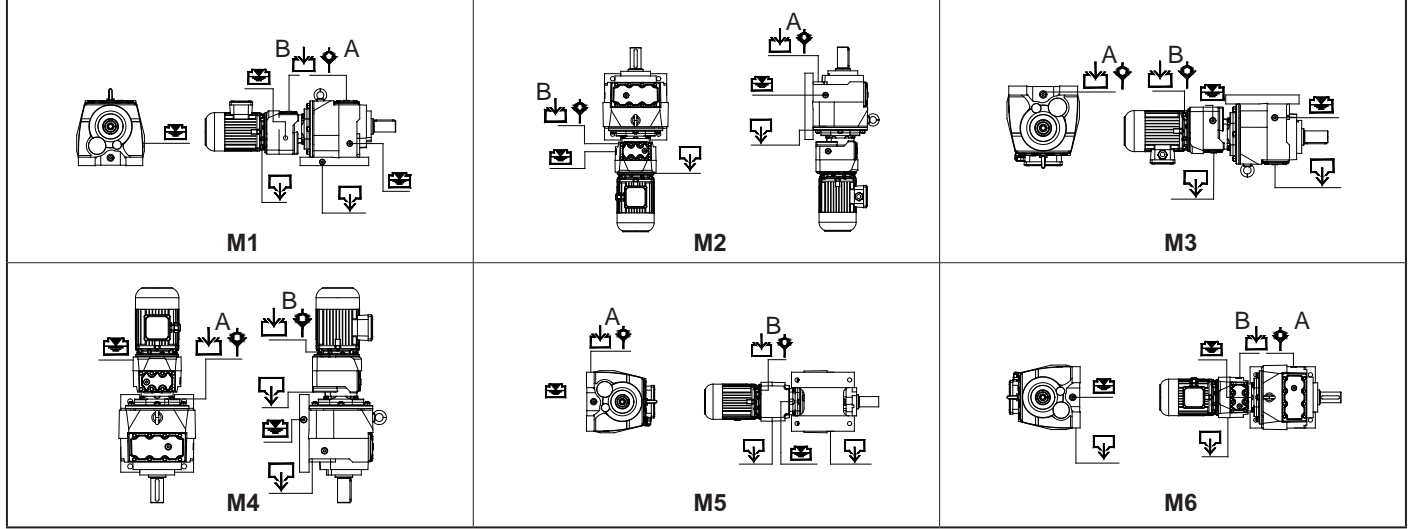

Yağ Miktarları (lt.) / Oil Quantities. (lt) / Ölmenngen (lt.)

Tip Type Typ	M Serisi 5-6 Kademe Yağ Miktarları M Series 5-6 Stages Oil Quantities Ölmenngen von M Serie mit 5-6 Stufen					
	M1 A / B	M2 A / B	M3 A / B	M4 A / B	M5 A / B	M6 A / B
M275	1 / 0.4	1.7 / 0.6	1.5 / 0.5	1.7 / 0.6	1.2 / 0.5	1.2 / 0.5
M285	1.6 / 0.7	2.85 / 0.95	2.5 / 0.7	2.85 / 0.95	2.4 / 0.7	2.4 / 0.7
M375	1.9 / 0.7	3.3 / 0.95	3 / 0.7	3.3 / 0.95	2.6 / 0.7	2.6 / 0.7
M475	4 / 1.2	7.6 / 2.1	7.01 / 2.1	7.6 / 2.1	5 / 1.4	5 / 1.4
M575	6 / 1.2	11.7 / 2.1	10.5 / 2	11.7 / 2.1	7.5 / 1.4	7.5 / 1.4
M675	8.5 / 2	20 / 3.4	18 / 3.1	20 / 3.4	11 / 2.8	10.5 / 2.8
M775	18 / 2	32 / 3.4	28 / 3.1	32 / 3.4	20 / 2.8	20 / 2.8
M875	20 / 2	45 / 3.4	39 / 3.1	45 / 3.4	28 / 2.8	28 / 2.8
M975	50 / 4.5	87 / 8	80 / 7.5	87 / 8	65 / 5.5	65 / 5.5
M276	1 / 0.4	1.7 / 0.55	1.5 / 0.5	1.7 / 0.55	1.2 / 0.4	1.2 / 0.4
M286	1.6 / 0.6	2.85 / 0.8	2.5 / 0.7	2.85 / 0.8	2.4 / 0.7	2.4 / 0.65
M376	1.9 / 0.6	3.3 / 0.8	3 / 0.7	3.3 / 0.8	2.6 / 0.7	2.6 / 0.65
M476	4 / 1.1	7.6 / 2	7 / 1.9	7.6 / 2	5 / 1.3	5 / 1.3
M576	6 / 1.1	11.7 / 2	10.5 / 1.9	11.7 / 2	7.5 / 1.3	7.5 / 1.3
M676	8.5 / 1.9	20 / 3.3	18 / 3	20 / 3.3	11 / 2.6	10.5 / 2.6
M776	18 / 1.9	32 / 3.3	28 / 3	32 / 3.3	20 / 2.6	20 / 2.6
M876	20 / 1.9	45 / 3.3	39 / 3	45 / 3.3	28 / 2.6	28 / 2.6
M976	50 / 4	87 / 7.6	80 / 7	87 / 7.6	65 / 5	65 / 5

Semboller :
Symbols :
Symbole :



:Yağ doldurma
:Oil filling
:Ölfüllung



:Yağ boşaltma
:Drain plug
:Ölauslass



:Yağ seviyesi
:Oil level
:Ölstand



:Havalandırma
:Vent Plug
:Entlüftungsschraube



Genel Bilgiler

General Information

Einführung



N Serisi Beş-Altı Kademeli Helisel Dişli Redüktörler Yağ Seviye Tapaları

N Series Five-Six Stage Helical Gearboxes Oil Level Plugs

N Serie Fünf-Sechsstufig Stirnradgetriebe Ölverschlußschrauben

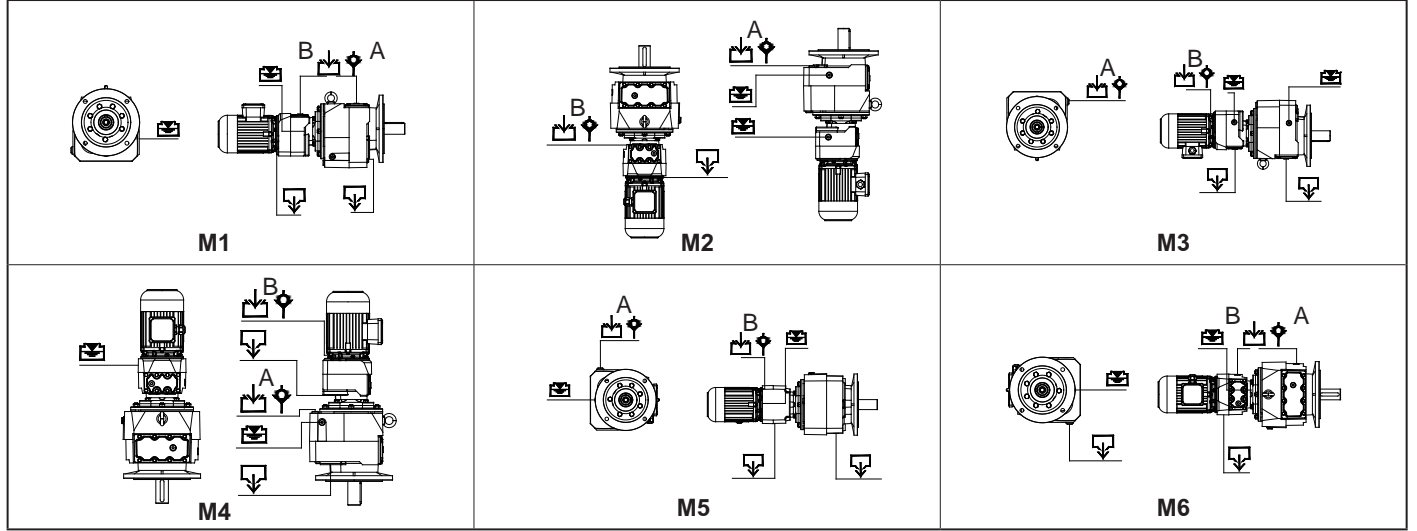

Yağ Miktarları (lt.) / Oil Quantities. (lt) / Ölmengen (lt.)

Tip Type Typ	N Serisi 5-6 Kademe Yağ Miktarları N Series 5-6 Stages Oil Quantities Ölmengen von N Serie mit 5-6 Stufen					
	M1 A / B	M2 A / B	M3 A / B	M4 A / B	M5 A / B	M6 A / B
N275	1 / 0.4	1.7 / 0.6	1.5 / 0.5	1.7 / 0.6	1.2 / 0.5	1.2 / 0.5
N285	1.6 / 0.7	2.85 / 0.95	2.5 / 0.7	2.85 / 0.95	2.4 / 0.7	2.4 / 0.7
N375	1.9 / 0.7	3.3 / 0.95	3 / 0.7	3.3 / 0.95	2.6 / 0.7	2.6 / 0.7
N475	4 / 1.2	7.6 / 2.1	7.01 / 2.1	7.6 / 2.1	5 / 1.4	5 / 1.4
N575	6 / 1.2	11.7 / 2.1	10.5 / 2	11.7 / 2.1	7.5 / 1.4	7.5 / 1.4
N675	8.5 / 2	20 / 3.4	18 / 3.1	20 / 3.4	11 / 2.8	10.5 / 2.8
N775	18 / 2	32 / 3.4	28 / 3.1	32 / 3.4	20 / 2.8	20 / 2.8
N875	20 / 2	45 / 3.4	39 / 3.1	45 / 3.4	28 / 2.8	28 / 2.8
N975	50 / 4.5	87 / 8	80 / 7.5	87 / 8	65 / 5.5	65 / 5.5
N276	1 / 0.4	1.7 / 0.55	1.5 / 0.5	1.7 / 0.55	1.2 / 0.4	1.2 / 0.4
N286	1.6 / 0.6	2.85 / 0.8	2.5 / 0.7	2.85 / 0.8	2.4 / 0.7	2.4 / 0.65
N376	1.9 / 0.6	3.3 / 0.8	3 / 0.7	3.3 / 0.8	2.6 / 0.7	2.6 / 0.65
N476	4 / 1.1	7.6 / 2	7 / 1.9	7.6 / 2	5 / 1.3	5 / 1.3
N576	6 / 1.1	11.7 / 2	10.5 / 1.9	11.7 / 2	7.5 / 1.3	7.5 / 1.3
N676	8.5 / 1.9	20 / 3.3	18 / 3	20 / 3.3	11 / 2.6	10.5 / 2.6
N776	18 / 1.9	32 / 3.3	28 / 3	32 / 3.3	20 / 2.6	20 / 2.6
N876	20 / 1.9	45 / 3.3	39 / 3	45 / 3.3	28 / 2.6	28 / 2.6
N976	50 / 4	87 / 7.6	80 / 7	87 / 7.6	65 / 5	65 / 5

Semboller :

Symbols :

Symbole :



:Yağ doldurma

:Oil filling

:Ölfüllung



:Yağ boşaltma

:Drain plug

:Ölauslass



:Yağ seviyesi

:Oil level

:Ölstand



:Havalandırma

:Vent Plug

:Entlüftungsschraube



Genel Bilgiler

General Information

Einführung



MOTORLAR

AC Motorlar

a- Genel Özellikler:

Basit konstrüksiyonlu, bakım gerektirmez, güvenilirliği yüksek ve uygun fiyatlı olmaları nedeni ile trifaze asenkron motorlar en çok kullanılan motor cinsidir. Bu motorların çalışma karakteristikleri moment-hız eğrisi ile belirlenir. Aşağıda bu karakteristik eğrisine bir örnek verilmiştir.

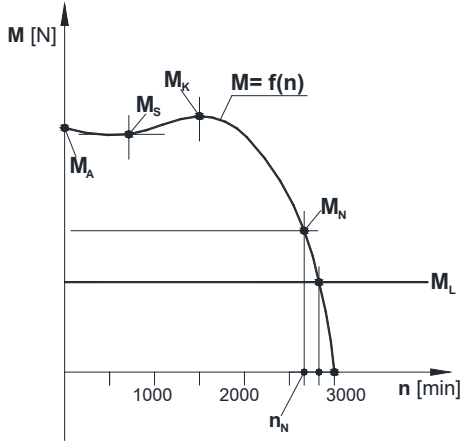

Motorun her start yapılmasında bu eğriye uygun hareket eder ve yük momenti M_L ile bu eğrinin çakıştığı nokta, motorun çalışma anındaki moment ve devirini verir.

Statorun manyetik alanı senkron hızla n_s döner. Kutuplar arasındaki faz kayması 3 fazlı motorlarda 120° 'dir.

$$n_s = 120 \times \frac{f}{p_s}$$

f.....: şebeke frekansı [Hz]
p_s.....: statorun kutup sayısı

Rotorun değişken manyetik alanı rotorun statorun manyetik alanının dönüşü yönünde dönmeye başlamasını sağlar. Rotor bu hareketinde statorun manyetik alanını takip eder ama hiçbir zaman yakalayamaz. Rotor statorun manyetik alanının hızından yavaş döner. Rotorun bu hızına baz hız n_N denir. Yükün azalması rotorun hızının artmasını sağlar, aynı zamanda sapma azalır olur. Sapma aşağıdaki gibi belirlenmiştir:

$$s = \frac{n_s - n_N}{n_s} \times 100$$

Sapmanın miktarına göre motorun nominal değerlerinde şu farklılıklar olabilir.

Sapma s: $\pm 20\%$
Kalkış Akımı.....: $\pm 20\%$
Kalkış Momenti.....: $-15/+25\%$
Kütle Atalet Momenti.....: $\pm 10\%$
Verim (37 kW'a kadar).....: $-0,15 (1-\eta)$

MOTORS

AC Motors

a- General Specifications:

On account of its simple and maintenance free construction, good reliability and price, the three phase squirrel cage motor is one of the most frequently employed electric motors. The run up behavior of a three phase squirrel cage motor is described by the torque-speed characteristic curve. An example is shown below.

M_A : Start momenti / Starting torque / Anlaufmoment

M_S : Demeraj momenti / Pull-up torque / Anziehungsmoment

M_K : Frenleme momenti / Pull-out torque / Bremsungsmoment

M_N : Motorun ilettiği moment / Motor rated torque / Treibmoment

M_L : Yük momenti / Load torque / Lastmoment

The motor follows this torque characteristics up to its stable operating point every time, when it is switched on. Operating point is that point, where the moment speed curve intersects with load torque M_L line.

The magnetic field in the stator rotates at a synchronous speed n_s . Phase shift of each pole is 120° at 3 phase motors.

$$n_s = 120 \times \frac{f}{p_s}$$

f.....: supply frequency [Hz]
p_s.....: number of stator poles

Because of the alternating magnetic field in the rotor, the rotor starts running in the same direction of the stator flux and tries to catch up with the rotating flux. The rotor never catches up the stator field. The rotor runs slower than the speed of the stator field. This speed is called the base speed n_N .

A decrease in load will cause the rotor to speed up or decrease slip. The slip is defined as follows:

$$s = \frac{n_s - n_N}{n_s} \times 100$$

According to the slip, the nominal values of the electric motor can alter as follows:

Slip s: $\pm 20\%$
Starting current: $\pm 20\%$
Starting torque: $-15/+25\%$
Moment of inertia.....: $\pm 10\%$
Efficiency (up to 37 kW).....: $-0,15 (1-\eta)$

MOTOREN

Drehstrommotoren:

a- Allgemeine Eigenschaften

Wegen die wartungsarme und leichte Konstruktion, hohe Sicherheit bei Nutzung und günstige Preise werden die asynchrone Drehstrommotoren am meisten benutzt. Motoranlaufverhalten wird mit Moment-Drehzahl-Kurve charakterisiert. Ein Beispiel ist unten angegeben.

Der Drehstrommotor läuft diese Kurve bei jeder Anlauf, bis dem stabilen Betriebspunkt erreicht wird. Betriebspunkt ist der Zustand, bei dem die Moment-Drehzahl-Kurve sich mit der Linie von erforderlichen Moment M_L schneidet.

Magnetisches Feld von Stator dreht sich mit synchroner Geschwindigkeit n_s . Phasenverschiebung von den Polen ist 120° bei 3phasigen Drehstrommotoren.

$$n_s = 120 \times \frac{f}{p_s}$$

f.....: Frequenz der Spannung [Hz]
p_s.....: Anzahl der Polen von Stator

Durch das magnetische Wechselfeld in den Rotor, beginnt der Rotor sich in der gleichen Richtung des Statorflusses zu drehen und versucht diese Bewegung aufzuholen. Der Rotor kann den Statorfeld nie aufholen. Die Rotorgeschwindigkeit nennt man Basisgeschwindigkeit n_N . Eine Abnahme der Belastung bewirkt, dass der Rotor sich beschleunigt und der Schlupf sich verringert. Der Schlupf wird wie folgt definiert:

$$s = \frac{n_s - n_N}{n_s} \times 100$$

Für die nominale Werte der Drehstrommotoren sind folgende Abweichungen zulässig:

Schlupf s: $\pm 20\%$
Anzugsstrom: $\pm 20\%$
Anzugsmoment: $-15/+25\%$
Massentägheitsmoment: $\pm 10\%$
Wirkungsgrad (bis 37 kW).....: $-0,15 (1-\eta)$



Genel Bilgiler

General Information

Einführung



b- Çalışma Türleri

Katalogta verilen tüm redüktörlerin motorları S1 çalışma türüne uygun verilmektedir. Diğer çalışma türleri aşağıdaki tabloda gösterilmiştir.

b-Modes of Operation

All motors of the catalogue have been laid out for duty S1 (continuous operation). Other duty types are given on the following table.

b-Betriebsarten

Die im Katalog angeführten Motoren sind für Betriebsart S1 (Dauerbetrieb) ausgelegt. Andere Betriebsarten sind unten angegeben.

Çalışma Türü Operation Betriebsarten	Açıklama Explanation Erläuterung	Yük Grafiği Load Graphic Lastverläufe
S1	Sabit yükte sürekli çalışma <i>Continuous operation under constant load</i> Dauerbetrieb mit konstanter Belastung	
S2	Sabit yükte kısa süreli çalışma <i>Short-time duty under constant load</i> Kurzbetrieb mit konstanter Belastung	
S3	Yolvermede sıcaklık artımı olmadan periyodik çalışma <i>Periodic duty without influence of start-up on temperature</i> Aussetzbetrieb ohne Einfluss des Anlaufes auf die Temperatur	
S4	Yolvermede sıcaklık artımı olan periyodik çalışma <i>Periodic duty with influence of start up on temperature</i> Aussetzbetrieb mit Einfluss des Anlaufes auf die Temperatur	
S5	Yolvermede ve frenlemede sıcaklık artımlı periyodik çalışma <i>Periodic duty with influence of startup and braking on temp.</i> Aussetzbetrieb mit Einfluss des Anlaufes / Bremsung auf die Temp.	
S6	Sürekli orta darbeleri çalışma <i>Continuous operation with intermittent loading</i> Durchlaufbetrieb mit Aussetzungsbelastung	
S7	Elektriksel frenlemeli sürekli orta darbeleri çalışma <i>Continuous operation with intermittent loading and braking</i> Ununterbrochener Betrieb mit Anlauf und Bremsung	
S8	Devir ve yük değişimli sürekli çalışma <i>Continuous operation duty type with related load-speed changes</i> Ununterbrochener periodischer Betrieb mit Drehzahländerung	



Genel Bilgiler

General Information

Einführung



c- Koruma Sınıfı:

Yılmaz Redüktörde standart olarak IP55 (IEC 34-5) koruma sınıfı motorlar kullanılmaktadır. Diğer koruma sınıfları istendiğinde firmamıza danışınız.

d- İzolasyon Sınıfı:

Yılmaz Redüktörde kullanılan standart izolasyon sınıfı F (IEC 317-8) dir. İstek üzerine H sınıfı yapılabilmektedir.

e- Verim Sınıfları:

Üç fazlı az gerilim asenkron motorların verim sınıfı ölçümü IEC 60034-2-1:2007 normu ile belirlenmiştir. Yeni IE verim sınıfı 0,75 kW'tan 375 kW'a kadar güç aralığında çalışan AC motorlar için geçerlidir. EFF verim sınıfından farklı olarak IE verim sınıfı 6 kutup sayılı motorlar içinde kullanılabilir. Aşağıda verim sınıfları sıralanmıştır. Bölgeler dışında verim sınıfı zorunlulukları ülkelere göre de farklılık gösterebilir. Lütfen firmamıza danışınız. Başka ürünlere entegre olmuş ve bu nedenle motorun veriminin bağımsız belirlenemediği sistemlerde (redüktör pompa gibi) verim sınıflandırması geçerli değildir.

c- Protection Class:

Yılmaz Redüktör uses IP55 (IEC 34-5) protection class electric motors for standard products. If different kind of protection class is requested please contact us.

d- Insulation Class:

Yılmaz Redüktör uses F (IEC 317-8) insulation class electric motors for standard products. H insulation class is available upon request.

e- Efficiency Classes:

The method for measuring the efficiency of low voltage three-phase asynchronous motors was revised with the new IEC 60034-2-1:2007 standard. The new IE classes is valid for AC Motors in power range from 0,75 to 375 kW. Unlike the EFF classes IE classes can be used for 6-pole AC motors. Below is the table of efficiency classes. The instructions for efficiency classes can differ from country to country. Please contact with us for more information. For the motors, which are fully integrated into a product (for example gear, pump) so their energy efficiency can not be recognized independently, the requirements of efficiency are not valid in Europe.

c- Schutzarten:

Yılmaz Redüktör Getriebemotoren werden serienmäßig mit Schutzart IP55 (IEC34-5) ausgeführt. Für andere Schutzarten bitte rückfragen.

d- Isolationsklasse:

Yılmaz Redüktör Getriebemotoren werden serienmäßig in Wärmeklasse F (IEC317-8) ausgeführt. H Wärmeklasse ist möglich auf Kundenwunsch.

e- Energieeffizienzklassen:

Die Methode für Messung die Effizienz von drei phasigen gering Spannung Asynchronmotoren hat neu mit IEC 60034-2-1:2007 Norm festgelegt. Die neue IE-Klassen gelten für alle Drehstrommotoren im Leistungsbereich von 0,75 bis 375 kW. Anders als EFF-Klassen die IE-Klassen können auch für 6-polige Drehstrommotoren verwendet werden. Unten steht die Tabelle der Effizienzklassen. Die Richtlinien für Effizienzklassen können sich je nach dem Land unterscheiden. Bitte mit unserem Firma Kontakt aufnehmen. Für die Motoren, die vollständig in ein Produkt (zum Beispiel Getriebe, Pumpe) eingebaut sind und deren Energieeffizienz nicht unabhängig von diesem Produkt erfasst werden kann, gelten in Europa die Anforderungen der Effizienzklassen nicht.

Verim Sınıfları Efficiency Classes Energieeffizienzklassen		4 Kutuplu Motor Verim Değeri Hesabi Calculating Efficiency Values of Motors with 4 Poles Berechnung der Wirkungsgrade von Elektromotoren mit 4 Polen	
IE1	EFF 2	Standart Verim Standart Efficiency Standarte Energieeffizienz	A=0,5234 B=-5,0499 C=17,4180 D=74,3171
IE2	EFF 1	Yüksek Verim High Efficiency Hohe Energieeffizienz	A=0,0278 B=-1,9247 C=10,4395 D=80,9761
IE3	-	Premium Verim Premium Efficiency Premium Energieeffizienz	A=0,0773 B=-1,8951 C=9,2984 D=83,7025
IE4	-	Süper Premium Verim Super Premium Efficiency Super Premium Energieeffizienz	-

$$\eta_{Mn} = A \times [\log_{10}(P_L)] + B \times [\log_{10}(P_L)]^2 + C \times \log_{10}(P_L) + D$$

P_L :Anma Yüğü [kW] / Nominal Load [kW] / Nennlast [kW]

η_{Mn} :Nominal verim / Nominal Efficiency / Sollwirkungsgrad

4 Kutuplu Motor Verim Değeri Efficiency Values of Motor with 4 poles Sollwirkungsgrad des Motors mit 4 Polen	Anma Yüğü [kW] Nominal Load [kW] Nennlast [kW]	Verim Sınıfı / Efficiency Class / Energieeffizienzklasse		
		IE1	IE2	IE3
	0,75	72,1 %	79,6 %	82,5 %
	1,5	77,2 %	82,8 %	85,3 %
	3	81,5 %	85,5 %	87,7 %
	7,5	86 %	88,7 %	90,4 %
	15	88,7 %	90,6 %	92,1 %
	22	89,9 %	91,6 %	93 %
	37	91,2 %	92,7 %	93,9 %
	45	91,7 %	93,1 %	94,2 %
	75	92,7 %	94 %	95 %
	90	93 %	94,2 %	95,2 %
	330	94 %	95,1 %	96 %



Genel Bilgiler General Information Einführung



f- AC Frekans İnvörtörler

Doğru Akımı (DC), alternatif akıma (AC) çeviren elektronik çeviricilere İnvörtör denilmektedir. AC motorlar için elektronik hız kontrol cihazları genellikle AC giriş akımını doğrultucu diyotlarla DC akıma çevirir ve daha sonra çevirici diyotlar vasıtasıyla bu akımı tekrar AC akıma çevirir. Doğrultucu diyotlar ile çevirici diyotlar arasındaki bağlantı DC-bağ olarak tanımlanmaktadır. DC kontrol cihazının (genellikle İnvörtör olarak isimlendirilir) elektriksel blok şeması aşağıda verilmiştir.

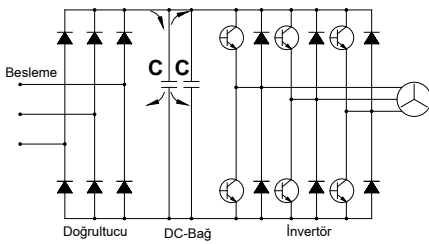

Tam dalga doğrultucuları besleyen üç faz besleme akımı DC-bağ kapasitörlerine iletilir. Kapasitörler voltajdaki dalgalanmaları azaltır ve kısa süreli ağıdaki akım kesintilerinde enerji sağlar. Kapasitörlerdeki voltaj kontrolsüzdür ve gelen AC akımın pik akım değerlerine bağlıdır. DC akım tekrar AC akıma, Puls genişliği modülasyonu (PWM) kullanılarak çevrilir. İstlenen dalga formu, sabit bir frekansta (Puls frekansında), çıkış transistörlerinin (İzole edilmiş geçit Bipolar transistörleri; IGBT'ler) açılıp kapatılması ile oluşturulur. IGBT'lerin açma kapama zamanlarının değişimi ile istenen akım oluşturulabilir. Çıkış voltajı bir seri kare dalga pulslardır ve motor sargılarının İndüktansı ile sinusoidal bir motor akımı oluşur. Puls genişliği modülasyonu aşağıda gösterilmiştir.

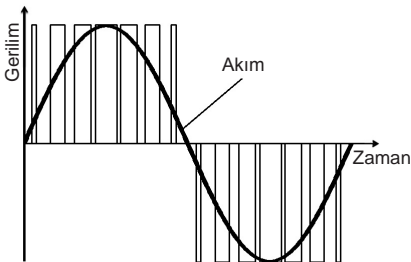

f- AC Frequency Inverters

An electronic converter is a device which converts Direct Current (DC) to Alternating Current (AC) is known as an inverter. Electronic speed controllers for AC motors usually convert the AC supply to DC using a rectifier, and then convert it back to a variable frequency, variable voltage AC supply using an inverter bridge. The connection between the rectifier and inverter is called the DC link. The block diagram of a speed controller (often called an inverter) is shown below.

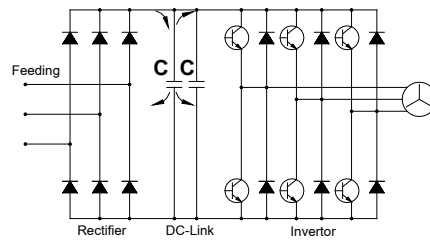

The three phase supply is fed into a full wave rectifier which supplies the DC link capacitors. The capacitors reduce the voltage ripple (especially on single supplies) and supply energy for short mains breaks. The voltage on the capacitors is uncontrolled and depends on the peak AC supply voltage. The DC voltage is converted back to AC using Pulse Width Modulation (PWM). The desired waveform is built up by switching the output transistors (Insulated Gate Bipolar Transistors; IGBTs) on and off at a fixed frequency (the switching frequency). By varying the on and off time of the IGBTs the desired current can be generated. The output voltage is still a series of square wave pulses and the inductance of the motor windings results in a sinusoidal motor current. Pulse Width Modulation is shown in the figure below.

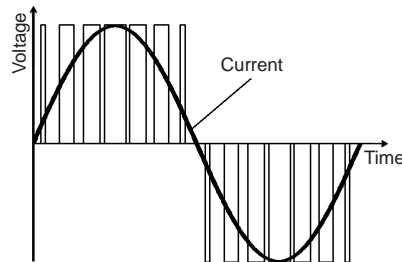

f- AC Frequenz Umrichter

Ein elektronischer Wandler, der den Gleichstrom (DC) in Wechselstrom (AC) umwandelt, wird als Umrichter bezeichnet. Ein Frequenzumrichter benutzt einen ungesteuerten Eingangsgleichrichter, um die Netzspannung in Gleichspannung umzuwandeln. Diese wird dann in den Zwischenkreiskondensatoren gespeichert. An diesem Gleichspannungszwischenkreis ist ein Wechselrichter angeschlossen. Dieser Wechselrichter erzeugt am Ausgang eine variable Frequenz und eine variable Spannung. Der Anschluss zwischen dem Gleichrichter und dem Wechselrichter nennt man Gleichstromverbindung. Das Blockschaltbild von diesem System wurde unten dargestellt:

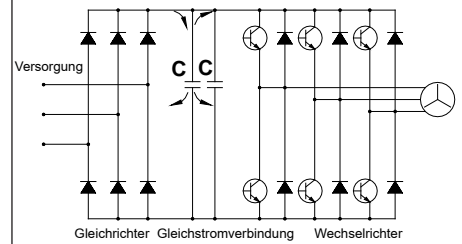

Auch bei dreiphasiger Versorgung wird die gleichrichtete Netzspannung den Zwischenkreiskondensatoren zugeführt. Die Kondensatoren reduzieren die Oberwelligkeit der Spannung (was besonders bei einphasiger Versorgung entscheidend ist) und liefern Energie, die kurze Unterbrechungen der Netzstromversorgung ermöglicht. Die Spannung der Kondensatoren ist vom Spitzenwert der Wechselspannung abhängig. Die Gleichspannung wird im Wechselrichter durch Pulsweitenmodulation (PWM) in Wechselspannung umgewandelt. Die gewünschte Wellenform wird durch Ein- und Ausschalten der Ausgangstransistoren (IGBT's Isolierte Gate Bipolar Transistoren) mit einer festen Frequenz (der Pulsfrequenz) erzeugt. Der gewünschte Strom kann durch die Variation der Ein- und Ausschaltzeit der Ausgangstransistoren generiert werden. Die Ausgangsspannung ist dadurch eine Reihe von Spannungsimpulsen, die in Verbindung mit der Induktivität der Motorspulen zu einem sinusförmigen Motorstrom führt. Die Pulsweitenmodulation wird wie folgt dargestellt

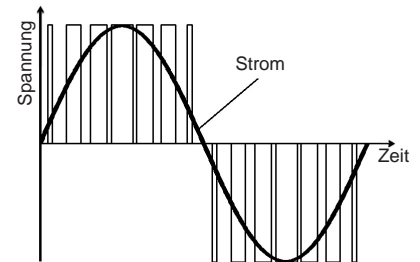



Genel Bilgiler

General Information

Einführung



DC MOTORLAR

a- Genel Özellikler

DC motorlar, elektronik parçalardaki gelişmeler nedeni ile yeni uygulama alanları bulmuştur. Daha önce çok pahalı olan ve ekonomik olmayan kontrol sistemlerinin yerini ucuz ve kompakt güç kontrol üniteleri almıştır. Yol vermenin kontrol altına alınabildiği, tork ve akım izlenebilirliği, aşırı yüklenmeye karşı elektronik koruma sağlanabilmesi ve daha birçok pahalı olmayan uygulamalar DC motorlarını cazip kılmaya başlamıştır.

b- DC Motorların Çalışma İlkeleri

DC motorlar için DC çıkış veren bir doğrultucuya ihtiyaç vardır. Motor armatür sargıları, alan sargıları, komutasyon sargıları ve kompanse sargılar olmak üzere rotorda ve statorda bulunan sargılardan oluşur. Rotora voltaj ve akım karbon fırçalar ve komutator sargılarla ulaştırılır. Bu karbon fırçalar aşındığından DC motorlar belirli periyotlarla bakıma alınmalıdır. İyi kontrol edilebilir özelliklerinden dolayı DC motorlar otomasyon teknolojisinde sıkça kullanılmaktadır.

c- DC Motor Çeşitleri

Temel olarak Şönt (Shunt) ve seri sargılı DC motorlar bulunmaktadır. Bu sargıların çeşidine göre moment eğrisi değişmektedir.

d- DC Motorlarda Hız Kontrolü

Bu motorlarda devir değişimi DC voltajın değiştirilmesi ile yapılır. Şönt sarımlı DC motorların sıfır yük ile maximum yük arasındaki davranışı AC motorlara benzer. Devir artan yükte beraber düşer. Bu devir farkı ufak güçlü motorlarda büyük, büyük güçlü motorlarda ise ufaktır. Fakat bu hız farkı DC doğrultucu cihazda armatür voltajı ($I \times R$) ile oynanarak kompanse edilebilir. Hassas hız kontrol gereksinimi olduğunda, tako jeneratörler kullanılabilir. DC motorların gücü aşağıdaki formülden hesaplanır;

$$P_g = U \times I = \frac{P_c}{\eta}$$

P_g : Giriş gücü W
 P_c : Çıkış gücü W
U : Armatür gerilimi V
I : Armatür akımı A
 η : Motor verimi

DC MOTORS

a- General Specifications of DC Motors

DC drive systems have found new possible applications with the development of the electronic components sector. What was previously extremely expensive and in some cases not economically feasible is nowadays realized by miniaturized power converter technology. Additional functions such as guided startup after a predetermined time, torque and current monitoring with electronic protection against overloading, and many inexpensive special applications have made DC drive systems more attractive.

b- Operating principles of the DC Motors

The DC motor requires, a converter with DC output. The motor includes windings, such as armature, field, commutation and compensation windings, which are arranged in the stator as well as on rotor. Voltage and current are supplied to the rotor via the carbon brushes and the commutator. The carbon brushes are wearing parts therefore a DC motor requires maintenance at service intervals. While its good control properties, the DC motor is an essential item in automation technology.

c- Types of DC Motors

Depending on the wiring of the exciting winding or field winding, two basically different variants are regards torque speed characteristics may be distinguished.

d- Speed Control of DC motors

In DC motors the speed is adjusted by altering the DC voltage. DC shunt wounded motors behave similar to three phase induction motors between no load operation and maximum load. The speed drops with increasing loading of the motor. This difference is greater in small motors and smaller in larger motors. The speed difference can be compensated in the DC converter device by adjusting ($I \times R$). If great control accuracy is required, a speed control with measurement of the actual values by a tachogenerator can be used. The power of DC motor;

$$P_g = U \times I = \frac{P_c}{\eta}$$

P_g : Input Power W
 P_c : Output Power W
U : Armature Voltage V
I : Armature Current A
 η : Motor efficiency

DC MOTOREN

a- Eigenschaften von DC Motoren

Mit den Entwicklungen bei elektronischen Komponenten haben DC Motoren neue Anwendungsbereiche gefunden. Regelungssysteme, die früher sehr teuer und im manchen Anwendungsfällen ungünstig waren, sind jetzt kompakt und günstig. Bei den DC Motoren ist kontrolliertes Anlauf, Moment- und Stromüberwachung mit Überlastschutz möglich. Es gibt viele günstige Sonderanwendungen für diese Motoren. Wegen oben genannten Eigenschaften werden die DC Motoren immer mehr bei unterschiedlichen Anwendungen benutzt.

b- Funktionsprinzip der DC Motoren

Bei DC Motoren ist eine Kommutatorwicklung im Rotor angeordnet, während der magnetische Fluss vom Stator erzeugt wird. Dies kann wiederum mittels einer Erregerwicklung oder durch Permanentmagnete geschehen. Wie bei der Synchronmaschine wird durch das Erregerfeld in der Ankerwicklung eine Wechsellspannung, die bei der Gleichstrommaschine jedoch durch den mechanischen Kommutator und die darauf schleifenden Bürsten in eine Gleichspannung umgeformt wird, induziert.

c- Arten von DC Motoren

Es gibt zwei verschiedene Wicklungen, nämlich Shunt- und Serial-Wicklung. Das Drehmoment-Drehzahl-Verhältnis ist für beide Wicklungen unterschiedlich.

d- Drehzahl Kontrolle für DC Motoren

Drehzahl von DC Motoren kann man mit Steuerung der DC Spannung ändern. DC Motoren mit Shunt Wicklungen ist ähnlich zu drei phasen AC Motoren zwischen maximalen Last und ohne Last. Drehzahl wird mit der Last reduziert. Mit kleineren Motoren wird dieser Differenz höher mit größeren Motoren kleiner. Der Drehzahlunterschied kann geregelt werden mit ($I \times R$) Veränderung. Wenn eine genaue Kontrolle gebraucht, soll ein Tachogenerator benutzt werden. Leistung des DC Motors;

$$P_g = U \times I = \frac{P_c}{\eta}$$

P_g : Eingangsleistung W
 P_c : Ausgangsleistung W
U : Ankerspannung V
I : Ankerstrom A
 η : Wirkungsgrad des Motors



Genel Bilgiler

General Information

Einführung



Elektromanyetik Frenler

Bu tip frenlerin iki sürtünme yüzeyi vardır. Fren torku, voltaj uygulanmadığı zaman yayların kuvveti ile oluşturulur. Fren elektromanyetik alanın oluşumu ile serbest kalır. Bobinin beslenmesi ile mıknatıslanan balata baskı pulu, elektromıknatısa doğru çekilir. Bu hareket yayları baskı altına alır ve rotor mili üzerine takılan çoklu kama üzerinde aksiyal yönde serbest hareket edebilen balata serbest kalır. Akım kesildiğinde yayların baskısıyla, balata baskı pulu fren balatasına doğru itilir ve bu hareket rotoru frenler.

Fren Çeşitleri

a) Soğutmasız tip frenler

Motor fanı çıkarılıp motor kapağı arkasına akuple edilerek kullanılan frenler; genellikle sıkça açılıp kapanmayan ve kısa zaman aralıklarında çalışan sistemlerde tercih edilir.

b) Soğutmalı tip frenler

Motor fanı çıkarılıp motor kapağı arkasına akuple edilen ve motorun mili uzatılarak fren ve motorun arkasına alınan fan sayesinde daimi bir hava sirkülasyonu sağlanarak kullanılan frenlerdir. Genellikle uzun süreli çalışan ve kapalı mekanlarda kullanılan sistemlerde tercih edilirler.

c) Manuel kol sistemli frenler

Çalışma sistemi olarak her iki fren tipinde de kullanılabilir (soğutmalı veya soğutmasız). Özel durumlarda (elektrik kesilmesi; mekanik problemler) üzerinde bulunan bir kol vasıtası ile sistemi yay baskısından kurtararak serbest kalmasını sağlayan frenlerdir. Genellikle manuel olarak sistemin açılması gereken yerlerde (otomatik giriş kapıları, dış cepe boyama asansörleri v.b.) tercih edilir.

Fren çalışma voltajları

Elektromanyetik frenler 230V AC veya 400V AC beslemeli olarak sipariş edilebilir. Frenler DC fren olmaları nedeni ile besleme ile fren bobini arasında fren tipine bağlı olarak, yarım dalga, tam dalga doğrultucular veya trafolar kullanılır. Özel olarak belirtilmedikçe 230V beslemeli ve yarım dalga doğrultuculu frenler kullanılmaktadır. Özel durumlar için YILMAZ Redüktöre danışınız.

a) 230V AC ile beslenen frenler

Motor klemens kutusundan alınan 230V'luk AC besleme fren tipine bağlı olarak yarım dalga veya tam dalga doğrultucu ile fren bobininin voltajına düşürülür. Fren bobin DC voltajı etiketi üzerinde belirtilmiştir.

b) 400V AC ile beslenen DC frenler

Motor klemens kutusundan alınan 400V'luk AC besleme, yarım dalga doğrultucu ile fren bobininin voltajına düşürülür. Fren bobininin DC voltajı etiket üzerinde belirtilmiştir.

c) 24V DC Frenler

Kullanılan fren momentinin büyüklüğüne göre besleme transformatörü seçilir. Şebekeden veya motorun klemens kutusundan alınan besleme voltajı transformatörde 29 V'a çevrilen gerilim tam dalga doğrultuculardan geçerek 24V DC'ye çevrilir ve fren bobini beslenir.

Electromagnetic Brakes

This type of brakes has two friction surfaces. Brake torque is generated by springs when no voltage is applied. The brake is electromagnetically released. On exciting the electromagnet means of the current, the armature plate is pulled towards the electromagnet itself, thrust loading the pressure spring and enabling the friction disc which is axially movable on the key, to turn freely. When current fails, the pressured springs drive the armature plate towards the disc, thus braking the motor shaft.

Brake Types

a) Brakes without cooling

This type of brakes are assembled on the back cover of the electric motor. There is no fan on the backside. This brake type is mostly preferred in short working times and short working cycles.

b) Fan cooled brakes

This type of brakes are assembled on the back cover of electric motor by removing the electric motor fan. A fan is coupled to the backside of the brake by extending the rotor shaft of the electric motor. Fan cooled brakes are preferred in long working times and closed places without airflow.

c) Brakes with hand release

This brakes can be released by help of an arm. It can be applied to both of the above mentioned brakes and used in special cases (fail of electric current, mechanical problems etc.) These brakes are mostly preferred if operation (releasing) without a current is needed (automatic controlled doors, gates, building wall painting elevators etc.).

Working Voltages

Electromagnetic brakes can be ordered with 230V AC or 400V AC supply voltage. The coil of brakes needs DC voltage and therefore depending on brake type a half wave, a full wave rectifier or transformer should be used between supply and coil voltage. As standard the brakes will be delivered with 230V supply voltage and half wave rectifier, if there is no special request. For special cases please contact YILMAZ Redüktör.

a) Brakes with 230V supply voltage

230V AC supply voltage from the motor terminal box will be reduced to the coil voltage depending on the brake type with half-wave or full-wave rectifier. DC brake coil voltage is indicated on the label.

b) Brakes with 400V supply voltage

400V AC supply voltage from the motor terminal box will be reduced to the coil voltage with half-wave rectifier. DC brake coil voltage indicated on the label.

c) 24V DC Brakes

The transformer's size is selected according to value of brake torque. The current is taken from the electric motor terminal box or from the electric panel and is transformed to 29V DC current. This current is transferred to 24V DC current with full-wave rectifier and supplies brake coil.

Elektromagnetische Bremsen

Die Bremse hat zwei Reibflächen und arbeitet nach dem Ruhestromprinzip. Im stromlosen Zustand wird das Bremsmoment durch den Druck der Feder erzeugt, während die Bremse beim Betrieb elektromagnetisch losgelassen wird. Durch die Erregung der Elektromagneten wird die Ankerscheibe zu den Elektromagneten gezogen und die Feder zusammengedrückt. Dadurch kann sich die Bremsenscheibe, die axial beweglich auf dem Mitnehmer angeordnet ist, frei drehen. Wird der Strom unterbrochen, drücken die Feder die Ankerscheibe gegen die Bremsenscheibe und halten die Motorwelle an.

Bremsearten:

a) Bremsen ohne Kühlung

Diese Bremsen sind für Kurzlaufzeiten geeignet. Die Lüfterhaube und Lüfter des Motors ist ausgebaut und die Bremse ist an dem Ende der Motorwelle befestigt.

b) Bremsen mit Kühlung

Diese Bremsen sind für lange Laufzeiten und kleine, abgedeckte Räume geeignet. Durch die Verlängerung der Motorwelle wurde Lüfter hinter dem Bremse und dem Motor verbunden. Somit wurde eine konstante Lüftung ermöglicht.

c) Bremsen mit Hebelarm

Diese Bremsenart kann mit oder ohne Kühlung verwendet werden. Diese Bremsen sind bei der speziellen Fälle, wie keine Spannung an der Leitung, mechanische Probleme usw., anwendbar. Die Bremse wird mit einem Hebelarm manuell betätigt. Diese Bremsen werden am meisten an den Stellen, wo die Lüftung ohne Spannung erfolgen soll, benutzt (automatische Türe, Wandaufzüge).

Betriebsspannungen

Elektromagnetische Bremsen können mit 230V AC oder 400V AC Versorgungsspannung bestellt werden. Die Wicklungen der Bremsen brauchen Gleichspannung und deswegen abhängig von Bremsenart zwischen Versorgungsspannung und Wicklungsspannung soll Halbwellen-, Vollweggleichrichter oder Transformator verwendet werden. Als Standard die Bremsen werden mit 230V Versorgungsspannung und Halbwellengleichrichter geliefert.

a) Bremsen mit 230V Versorgungsspannung

230V AC Versorgungsspannung von Klemmenkasten wird auf die Wicklungsspannung abhängig von der Bremsentyp mit Halbwellen- oder Vollweggleichrichter reduziert. Wicklungsspannung ist auf dem Etikett angegeben.

b) Bremsen mit 400V Versorgungsspannung

400V AC Versorgungsspannung von Klemmenkasten wird auf die Wicklungsspannung mit Halbwellengleichrichter reduziert. Wicklungsspannung ist auf dem Etikett angegeben.

c) 24 V DC Bremsen

Die Spannung wird von den Klemmkasten des Motors oder Elektrischrank entnommen. Diese Spannung wird zuerst mittels Transformator zu 24 V reduziert. Danach wird diese Spannung mit Hilfe von Gleichrichter zu Gleichstromspannung umgewandelt. Die Größe des Transformators ist abhängig von der Größe des Bremsmoments.



Genel Bilgiler

General Information

Einführung



d) Şok ikazlı trafolar

Büyük güçteki ve momentteki frenlerin manyetik doyuma ulaşmaları uzun zaman alır. Şok ikazlı trafolar frenin yay baskısını yenmede gecikmesini engellemek için kullanılır ve zaman rölesi yardımı ile çok kısa bir süre normal besleme voltajının iki katı ile (48V DC) beslenip sistemin ani açılmasını sağlar. Bu sayede gecikmeli açılmada ortaya çıkacak sürtünmeyi engellemeye yarayan bir trafo şeklindedir.

Fren bağlantı şekli

a) Gecikmeli frenleme

Genellikle sistemin yavaş ve kaydırılarak durması gereken yerlerde tercih edilen bağlantı şeklidir. Vinç yürütme motorlarındaki sarsıntıyı önlemek için gecikmeli bağlantı şekli kullanılır. Frenler fabrika çıkışında gecikmeli bağlantıya uygun ayarlanır.

b) Ani frenleme

Genellikle sistemin enerjisi kesildiği anda ani olarak durdurulması gereken sistemlerde kullanılan bağlantı şeklidir. Vinç kaldırma sistemleri, asansör motorlarında kullanılan bağlantı şeklidir.

d) Shock voltage supply transformer

Brakes which consist of high power and torques take long time to get in electromagnetic field. Shock voltage supply transformers with time relay are aiming to overcome spring pressure delaying for brakes. Also this transformers provide to open system suddenly by feeding double(48V DC) voltage in a short time and preventing to frictional losses occurring in delayed opening.

Connection Types

a) Delayed Braking

Generally this type of connection uses in slow and sliding brake intended systems. Delayed connection type using to prevent shock loadings in crane driving systems. Brakes are setting up to delayed connection if any other types are not specified by customer

b) Sudden Braking

This type of connections are mostly used in systems when short braking times are needed. The braking torque will be produced as soon as the current fails. These brakes are mostly used in hoisting of lifting units and elevators.

d) Trafos mit Schock-Spannung

Diese Transformatoren werden bei großen Bremsen mit hohen Momenten verwendet. Da die große Bremsen eine lange Zeit braucht, um die erforderliche magnetische Feld zu erzeugen, wird an der Bremse kurz 48V Gleichstromspannung angelegt, um die Zeit zur Bildung von magnetischem Feld zu kürzen. Dies ermöglicht kürzere Reibungszeiten beim Start.

Schaltungsarten:

a) Verspätetes Bremsen

Diese Schaltung wird benutzt, wenn ein langsames und gleitendes Bremsen erforderlich ist. Am meisten wird es bei Fahrtriebemotoren von Aufzügen verwendet. Wenn keine Angabe bei der Bestellung gegeben wird, werden die Bremsen mit verspäteter Schaltung geliefert.

b) Schnelles Bremsen:

Allgemein verwendet man diese Schaltung bei Bedarf an plötzlichen Bremsen in dem Augenblick, in dem das System keine Energie mehr erhält. Diese Schaltungsart wird meist bei Kräne und Motoren von Aufzüge verwendet.

Gecikmeli Frenleme / Delayed Running Brake / Verspätete Bremsung
(230 V)

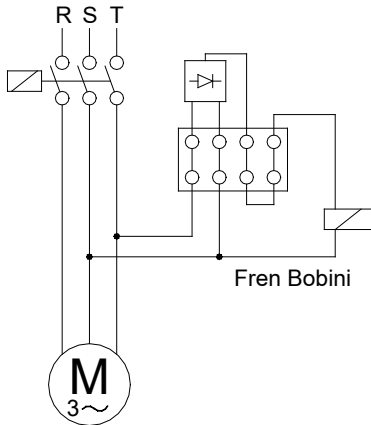

Ani Frenleme / Sudden Brake / Plötzliche Bremsung
(230 V)

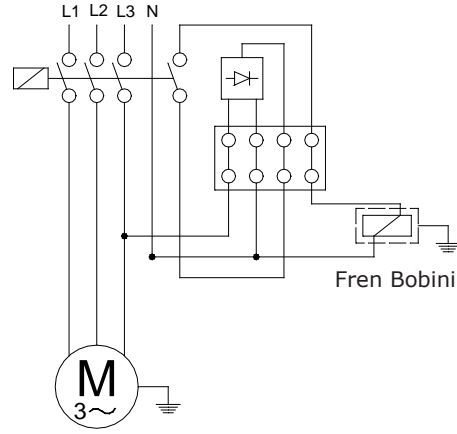

Gecikmeli Frenleme / Delayed Running Brake / Verspätete Bremsung
(24 V)

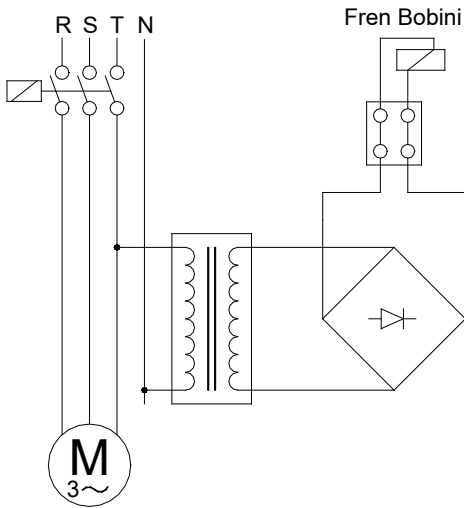

Ani Frenleme / Sudden Brake / Plötzliche Bremsung
(24 V)

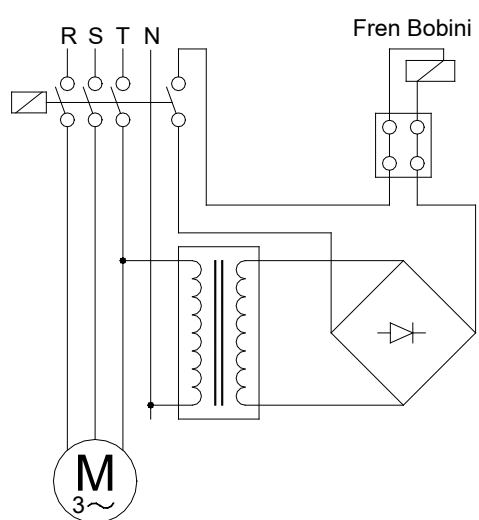



Genel Bilgiler

General Information

Einführung



Fren Seçimi:

Doğru bir fren seçimi için aşağıdaki parametreler bilinmelidir.

- I_{tot} [kg.m²] : Motor miline indirgenmiş toplam atalet momenti
- n_0 [d/dak] : Maksimum motor devir sayısı
- t_f [s] : İstenilen en uzun frenleme zamanı
- c_t : Anahtarın devreye girme zamanı katsayısı (ortalama 0,995).
- M_L [Nm] : Sistemin statik tork ihtiyacı.
- C_s : Emniyet katsayısı ($C_s \geq 2$ olmalı)

Gerekli fren momenti aşağıdaki şekilde hesaplanır:

a) M_L Statik yük torku, motor dönüş yönünde (motorun dönüşüne yardımcı olarak, yükün indirilmesi veya hızlandırıcı sabit yük momenti hali):

$$M_{fc} = \frac{(2\pi \times n_0 \div 60) \times I_{tot}}{t_f \times c_t} + M_L$$

b) M_L Statik yük torku, motor aksi dönüş yönünde (motorun dönüşüne engel olarak, yükün yukarı kaldırılması veya frenleyici sabit yük/direnç momenti hali):

$$M_{fc} = \frac{(2\pi \times n_0 \div 60) \times I_{tot}}{t_f \times c_t} - M_L$$

Yukarıda bulunan sonuç C_s katsayısı ile çarpılarak ($C_s \geq 2$), fren momenti seçilir;

$$M_f = M_{fc} \times C_s$$

Yaklaşım Yolu ile Fren Seçimi:

Eğer yalnızca motorun gücü ve en yüksek devri biliniyor ise :

W [Watt]: Motorun nominal gücü

$$M_f = \frac{W}{\left(\frac{2\pi \times n_0}{60}\right)} \times C_s \quad (C_s \geq 2)$$

Standart Frenler / Standard Brakes / Standart Bremsen

Fren statik momenti [Nm] Brake Static Torque [Nm] Statische Bremskraft [Nm]	4,5	8	12	16	35	60	80	150	200
Fren Dinamik Momenti [Nm] Brake Dynamic Torque [Nm] Dynamische Bremskraft [Nm]	3,6	6,4	9,6	12,8	28	48	64	120	160
Maksimum Motor Hızı [d/dak] Maximum Motor Speed [rpm] Maximale Motordrehzahl [U/min]	3000	3000	3000	3000	3000	3000	3000	1500	1500
Giriş Gücü [W] Input Power [W] Antriebsleistung [W]	15	20	25	30	45	50	55	60	65

Brake Selection:

To select a brake correctly the following data are necessary;

- I_{tot} [kg . m²] : The total inertia of rotating parts reduced at the motor shaft
- n_0 [rpm] : Maximum motor speed.
- t_f [s] : The maximum admitted time of the braking.
- c_t : Coefficient of switch on time (average 0,995).
- M_L [Nm] : Required static torque of system.
- C_s : Safety coefficient ($C_s \geq 2$)

The necessary braking torque calculates below;

a) The static load torque M_L , same direction of motor rotation (Descent of a load or steady resisting torque which favours the rotation of the motor)

$$M_{fc} = \frac{(2\pi \times n_0 \div 60) \times I_{tot}}{t_f \times c_t} + M_L$$

b) The static load torque M_L , opposes the rotation of the motor (Lifting of a load or steady resisting torque which opposes the rotation of the motor)

$$M_{fc} = \frac{(2\pi \times n_0 \div 60) \times I_{tot}}{t_f \times c_t} - M_L$$

The necessary braking torque will result from the following equation using C_s ($C_s \geq 2$);

$$M_f = M_{fc} \times C_s$$

Approximated Brake Selection

Its only the motor power and its maximum speed are known:

W [Watt]: Motor Nominal Power

$$M_f = \frac{W}{\left(\frac{2\pi \times n_0}{60}\right)} \times C_s \quad (C_s \geq 2)$$

Bremswahl:

Um die richtige Bremse auszuwählen, braucht man unten aufgelistete Variablen;

- I_{tot} [kg . m²] : Die Gesamtträgheit der rotierenden Teile (siehe Anwendungsbeispiele)
- n_0 [U/min] : Die höchste Drehzahl des Motors
- t_f [s] : Die längste zulässige Bremszeit
- c_t : Reduktionskoeffizient der Tätigkeitszeit (gemittelt 0,995).
- M_L [Nm] : Vom system benötigtes, statisches Drehmoment.
- C_s : Sicherheitskoeffizient ($C_s \geq 2$)

Die benötigte Bremskraft wird wie folgt berechnet:

a) konstantes Belastungsmoment M_L , das die Motordrehung fördert (konstante Erhöhung der Motorgeschwindigkeit oder Herunterlassen der Last)

$$M_{fc} = \frac{(2\pi \times n_0 \div 60) \times I_{tot}}{t_f \times c_t} + M_L$$

b) konstantes Belastungsmoment M_L , das sich entgegen der Motordrehung widersetzt (konstante Verminderung der Motorgeschwindigkeit oder Aufheben der Last)

$$M_{fc} = \frac{(2\pi \times n_0 \div 60) \times I_{tot}}{t_f \times c_t} - M_L$$

Wenn die Bremskraft mit dem Sicherheitskoeffizient C_s ($C_s \geq 2$) multipliziert wird, erhält man die erforderliche Bremskraft;

$$M_f = M_{fc} \times C_s$$

Abschätzung zur Bremswahl

Wenn man nur die Motorleistung und die höchste Drehzahl kennt, kann die Bremskraft mit der folgenden Formel annähernd berechnet werden:
W [Watt] : Nennleistung des Motors

$$M_f = \frac{W}{\left(\frac{2\pi \times n_0}{60}\right)} \times C_s \quad (C_s \geq 2)$$

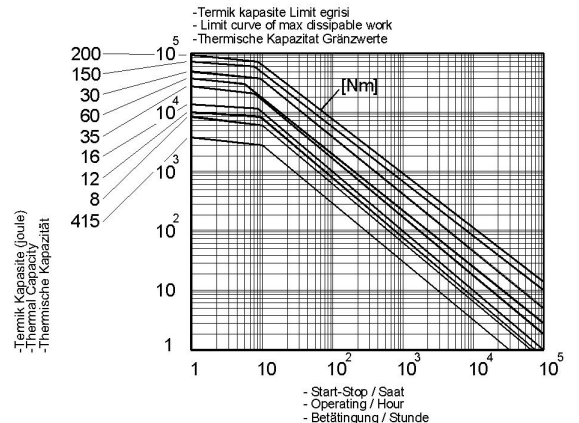



Genel Bilgiler

General Information

Einführung



Frenin Termik Kapasitesi

Yukarıdaki seçime ek olarak frenin termik kapasitesinin kontrol edilmesi gerekir. L (joule) olarak gerekli soğutma işi aşağıdaki formüller ile hesaplanır ve "Termik kapasite limit eğrisi" kullanılarak eğrinin altında kalıp kalmadığı kontrol edilir.

a) M_L Statik yük torku motor dönüş yönünde (motorun dönüşüne yardımcı olarak, yükün indirilmesi hali)

$$L = \frac{I_{tot} \times (2 \pi \times n_0 \div 60)^2}{2} \times \left(\frac{M_f}{M_f - M_L} \right)$$

b) M_L Statik yük torku motor aksi dönüş yönünde (motorun dönüşüne engel olarak, yükün kaldırılması hali):

$$L = \frac{I_{tot} \times (2 \pi \times n_0 \div 60)^2}{2} \times \frac{M_f}{M_f + M_L}$$

c) M_L Statik yük torku sabit, motor yönünde veya aksi yönde (kaldırma ve indirme harici hızlandırıcı veya frenleyici sabit bir yük momenti hali).

$$L = \frac{I_{tot} \times (2 \pi \times n_0 \div 60)^2}{2}$$

Fren Hava Boşluğunun Ayarı:

Frenin sürekli aynı performansın alınabilmesi için, fren balatasının aşınmasına bağlı olarak, fren hava boşluğu belirli zaman aralıklarında yeniden ayarlanmalıdır. Fren hava boşluğu ayar zaman aralığı ve ayarın yapılması için firmamıza danışınız.

Fren Seçim Örneği:

İstenilen en uzun frenleme zamanı: 0,5 sn.
Motor devri: 1400 d/dak
Motora indirgenmiş toplam atalet momenti: 0,08 kgm²

Gerekli çalışma momenti: 50 Nm

Yük Durumu: Yük motor dönüş yönü ile aynı (Vinçten yük indirilmesi: Saatte dur-kalk sayısı:30)

$$M_{fc} = \frac{(2 \pi \times 1400 \div 60)}{0,5 \times 0,995} + 50 = 73,6 \text{ Nm}$$

$$M_f = 73,6 \times 2 = 147,2 \text{ Nm}$$

Standart frenler tablosundan 150 Nm lik fren seçilebilir.

Gerekli termik kapasite;

$$L = \frac{0,08 \times (2 \pi \times 1400 \div 60)^2}{2} \times \left(\frac{147,2}{147,2 - 50} \right)$$

=1302,0 < 18000 Joule (150 Nm eğrisinden)
150 Nm lik fren uygun görülüyor.

The Thermal Capacity of Brake

The thermal capacity of the brake must also be checked after the above mentioned calculations heat dissipation energy L (joule) can be calculated from the following equation and must be checked if the result is under the limit curve shown on "Limit curve of may dissipated work".

a) The static load torque M_L , favours the rotation of the motor (Descent of a load which favours the rotation of the motor)

$$L = \frac{I_{tot} \times (2 \pi \times n_0 \div 60)^2}{2} \times \left(\frac{M_f}{M_f - M_L} \right)$$

b) The static load torque M_L , opposes the rotation of the motor (Lifting of a load which opposes the rotation of the motor)

$$L = \frac{I_{tot} \times (2 \pi \times n_0 \div 60)^2}{2} \times \frac{M_f}{M_f + M_L}$$

c) The static load torque M_L , is constant and opposes or favours the rotation of the motor (except lifting of a load)

$$L = \frac{I_{tot} \times (2 \pi \times n_0 \div 60)^2}{2}$$

Adjustment of the air-gap:

In order to obtain the same performance from the brake during its lifetime, the air-gap of the brake must be re-adjusted after a limited time of operation. For the air-gap and the time interval of the adjustment please contact us.

Selection Example:

The maximum admitted time for braking 0,5 s
Motor speed: 1400 rpm
Total inertia reduced at motor shaft: 0,08 kgm²

Required operating torque: 50 Nm

Nature of load: Load direction is same as motor direction (Unloading process: Start-stop time per hour :30)

$$M_{fc} = \frac{(2 \pi \times 1400 \div 60)}{0,5 \times 0,995} + 50 = 73,6 \text{ Nm}$$

$$M_f = 73,6 \times 2 = 147,2 \text{ Nm}$$

From the brake selection table a standard brake of 150 Nm is selected.

Necessary thermal capacity

$$L = \frac{0,08 \times (2 \pi \times 1400 \div 60)^2}{2} \times \left(\frac{147,2}{147,2 - 50} \right)$$

=1302,0 < 18000 Joule (from 150 Nm curve)
The selected brake with 150 Nm is suitable.

Thermische Kapazität der Bremsen

Nach den oben genannten Berechnungen muss die thermische Kapazität überprüft werden. Die Wärme, d.h. die gebrauchte Energie L, werden mit den folgenden Formeln berechnet. Die gerechnete Werte von Kapazitäten sollen unter dem Grenzkurve "Thermische Kapazität Grenzwerte" der gewählten Bremse liegen.

a) Konstantes Belastungsmoment M_L , das die Motordrehung fördert (Herunterlassen der Last)

$$L = \frac{I_{tot} \times (2 \pi \times n_0 \div 60)^2}{2} \times \left(\frac{M_f}{M_f - M_L} \right)$$

b) Konstantes Belastungsmoment M_L , das sich entgegen der Motordrehung widersetzt (Aufheben der Last)

$$L = \frac{I_{tot} \times (2 \pi \times n_0 \div 60)^2}{2} \times \frac{M_f}{M_f + M_L}$$

c) Konstantes Belastungsmoment M_L , das sich gegen der Motorbewegung widersetzt oder die Motorrotation fördert (Konstante Verminderung oder Erhöhung der Motorgeschwindigkeit, kein Herunterlassen oder Aufheben der Last)

$$L = \frac{I_{tot} \times (2 \pi \times n_0 \div 60)^2}{2}$$

Einstellung des Luftspaltes:

Um eine immer konstant bleibende Bremsfähigkeit zu erhalten, muss das Luftspalt nach einer bestimmten Arbeitszeit neu eingestellt werden. Für die Bestimmung des Luftspaltes und die Einstellzeiten bitten wir Sie um Rückfrage.

Beispiel für eine Auswahl:

Die höchste zulässige Bremszeit: 0,5 s
Motordrehzahl: 1400 U/min
Gesamträgheit der rotierenden Teile: 0,08 kgm²
Das auf das System wirkende Drehmoment: 50 Nm
Belastungsart: Drehmoment, das die Motorrotation fördert (Herunterlassen der Last)
Betätigungen pro Stunde: 30

$$M_{fc} = \frac{(2 \pi \times 1400 \div 60)}{0,5 \times 0,995} + 50 = 73,6 \text{ Nm}$$

$$M_f = 73,6 \times 2 = 147,2 \text{ Nm}$$

Eine Bremse von 150 Nm kann man auswählen.

Die thermische Kapazität;

$$L = \frac{0,08 \times (2 \pi \times 1400 \div 60)^2}{2} \times \left(\frac{147,2}{147,2 - 50} \right)$$

=1302,0 < 18000 Joule (von 150 Nm Kurve) Die ausgewählte 150 Nm Bremse ist ausreichend.

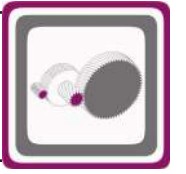

Güç ve Devir Tabloları

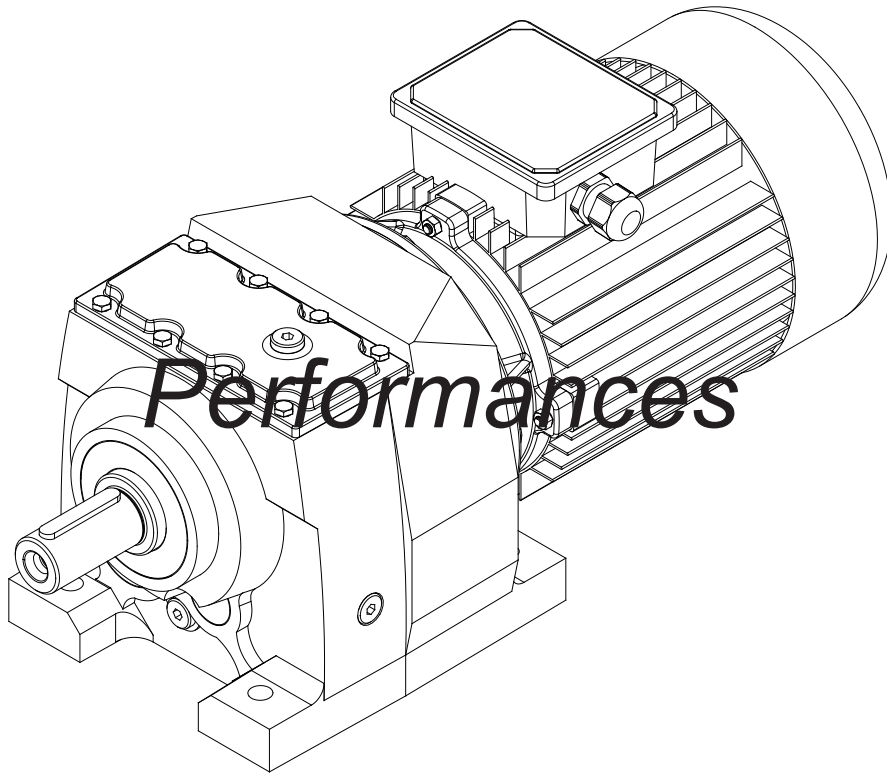

Leistung und Drehzahlübersicht



Motorlu Güç Devir Sayfaları

Geared Motors Performance Tables

Leistung und Drehzahlübersicht von Getriebemotoren



Güç	Çıkış Devri	Çıkış Momenti	Çevrim Oranı	Güv. Rad. Yük Çıkış	Servis Faktörü	Tipi	Anma Akımı	Ağırlık	Ölçü Sayfası	Fiyat Kodu
Power	Output Speeds	Output Torque	Ratio	Per.O. Loads (Output)	Service Factors	Type	Rated Current	Weight	Dim. Page	Price Ref.
Leistung P _g [kW] P _g [HP]	Abtriebswelle Drehzahlen n ₂ [r.p.m]	Abtriebswelle Drehmomente M ₂ [Nm]	Übersetzung i	Zul.Querkräfte (Abtrieb) F _{qam} [N]	Betriebsfaktor f _s	Typ	Nennstrom [A]	Gewicht ~ [kg]	Maße Seite	Preis No.
0,12 0,18	0,28	3161	4953,44	18719	0,9	MR576-63/4a	0,41	157	119	MR402
	0,32	2811	4402,68	20916	1,1	NR576-63/4a		151		NR402
	0,42	2157	3372,36	24268	1,4					
	0,49	1825	2850,22	25640	1,6					
	0,51	1786	2736,94	25789	1,7	MR575-63/4a	0,41	155	119	MR403
	0,61	1511	2313,18	26807	2,0	NR575-63/4a		149		NR403
	0,74	1239	1897,20	27712	2,4					
	0,84	1095	1675,43	28156	2,7					
	0,94	973	1489,14	28508	3,1					
	1,1	824	1259,61	28915	3,6					
	1,2	748	1140,65	29153	4,0					
	0,55	1648	2522,85	13992	0,9	MR475-63/4a	0,41	100	116	MR003
0,66	1378	2107,15	17772	1,1	NR475-63/4a		103		NR003	
0,70	1302	1990,76	18643	1,2						
0,81	1139	1738,98	20338	1,4						
0,86	1070	1631,08	21007	1,4						
1,0	910	1386,75	22317	1,7						
1,1	845	1285,79	22818	1,8						
1,2	792	1204,49	23218	2,0						
1,3	694	1053,93	23939	2,2						
1,5	617	934,94	24430	2,5						
0,90	1019	1561,78	7642	0,8	MR375-63/4a	0,41	76	113	MR004	
1,0	902	1380,71	10238	0,9	NR375-63/4a		78		NR004	
1,2	759	1161,33	12601	1,1						
1,4	646	987,33	14090	1,3						
1,7	554	845,97	15082	1,5						
1,8	501	765,58	15595	1,6						
2,1	443	676,02	16127	1,8						
2,2	414	631,45	16378	2,0						
2,6	351	533,70	16915	2,3						
2,7	352	524,07	16901	2,3	MR374-63/4a	0,41	55	112	MR005	
3,3	284	421,85	17401	2,9	NR374-63/4a		58		NR005	
3,8	249	369,93	17646	3,3						
1,2	789	1206,98	3708	0,8	MR285-63/4a	0,41	74	110	MR006	
1,4	664	1015,21	7884	0,9	NR285-63/4a		75		NR006	
1,6	565	863,11	9893	1,1						
1,9	484	739,53	11164	1,2						
2,1	439	669,25	11789	1,4						
2,4	375	573,81	12571	1,6						
2,8	322	491,50	13143	1,9						
3,2	290	431,18	13466	2,1	MR284-63/4a	0,41	74	109	MR007	
3,8	248	368,77	13836	2,4	NR284-63/4a		75		NR007	
4,3	218	323,39	14123	2,8						
1,7	541	827,44	5983	0,8	MR275-63/4a	0,41	41	107	MR008	
1,9	474	724,01	6562	0,9	NR275-63/4a		43		NR008	
2,3	392	598,70	7152	1,1						
2,8	328	499,32	7553	1,4						
3,3	275	418,57	7843	1,6						
3,9	236	358,33	8034	1,9						
4,2	219	332,52	8108	2,1						
5,6	166	252,20	8350	2,7						



Motorlu Güç Devir Sayfaları

Geared Motors Performance Tables

Leistung und Drehzahlübersicht von Getriebemotoren

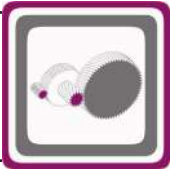

Güç	Çıkış Devri	Çıkış Momenti	Çevrim Oranı	Güv. Rad. Yük Çıkış	Servis Faktörü	Tipi	Anma Akımı	Ağırlık	Ölçü Sayfası	Fiyat Kodu
Power	Output Speeds	Output Torque	Ratio	Per.O. Loads (Output)	Service Factors	Type	Rated Current	Weight	Dim. Page	Price Ref.
Leistung P _g [kW] P _g [HP]	Abtriebswelle Drehzahlen n ₂ [r.p.m]	Abtriebswelle Drehmomente M ₂ [Nm]	Übersetzung i	Zul.Querkräfte (Abtrieb) F _{qam} [N]	Betriebsfaktor f _s	Typ	Nennstrom [A]	Gewicht ~ [kg]	Maße Seite	Preis No.
0,12 0,18	6,5	142	215,91	8.446	3,2	MR275-63/4a	0,41	41	107	MR008
	6,8	135	205,95	8.474	3,3	NR275-63/4a		43		NR008
	7,8	119	180,21	8.540	3,8					
	9,4	98	149,02	8.615	4,0					
	10	105	138,55	8.588	4,0	MR273-63/4a	0,41	30	106	MR009
	12	91	121,03	8.640	4,0	NR273-63/4a		32		NR009
	13	86	113,52	8.656	4,0					
	14	75	99,21	5723	2,7	MR173-63/4a	0,41	30	104	MR010
	16	66	87,60	5524	3,0	NR173-63/4a		32		NR010
	17	62	81,82	5417	3,2					
	20	52	69,16	5159	3,8					
	24	44	57,76	4891	4,0					
	28	38	49,81	4679	4,0					
	31	34	45,18	2844	2,4	MR003-63/4a	0,41	12	102	MR011
	35	30	40,04	2862	2,7	NR003-63/4a		13		NR011
	44	24	32,02	2894	3,4					
	49	21	28,38	2906	3,8					
	58	18	24,13	2773	4,0					
	66	16	21,26	2655	4,0					
	68	16	20,66	2626	4,0					
	73	15	19,17	2558	4,0					
	77	14	18,20	2515	4,0					
	83	13	16,89	2450	4,0					
	95	11	14,67	2337	4,0					
	103	10	13,61	2277	4,0					
	126	9	11,14	2137	4,0	MR002-63/4a	0,41	11	102	MR012
	142	8	9,87	2050	4,0	NR002-63/4a		12		NR012
161	7	8,70	1963	4,0						
166	6	8,45	1942	4,0						
179	6	7,84	1892	4,0						
188	6	7,45	1860	4,0						
203	5	6,91	1812	4,0						
233	5	6,00	1727	4,0						
251	4	5,57	1684	4,0						
307	3	4,56	1574	4,0						
359	3	3,90	1493	4,0						
387	3	3,62	1455	4,0						
0,18 0,25	0,11	13102	8345,18	71858	1,0	MR876-71/6a	0,61	605	128	MR013
	0,12	11333	7233,00	81412	1,1	NR876-71/6a		620		NR013
	0,14	9902	6313,78	87961	1,3					
	0,16	8741	5569,66	92611	1,5					
	0,18	7781	4954,95	96036	1,7					
	0,20	6974	4438,59	98943	1,9					
	0,23	6125	3892,30	101645	2,1					
	0,26	5423	3441,02	103736	2,4					
	0,31	4571	2894,28	106104	2,8					
	0,37	3893	2460,65	107857	3,3					
	0,15	9332	5949,83	43189	0,9	MR776-71/6a	0,61	258	125	MR404
	0,17	8263	5260,00	47843	1,0	NR776-71/6a		320		NR404
	0,19	7732	4812,09	49999	1,0	MR775-71/6a	0,61	255	125	MR405
	0,21	6850	4263,81	53064	1,2	NR775-71/6a		315		NR405



Motorlu Güç Devir Sayfaları

Geared Motors Performance Tables

Leistung und Drehzahlübersicht von Getriebemotoren

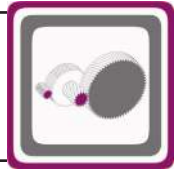

Güç	Çıkış Devri	Çıkış Momenti	Çevrim Oranı	Güv. Rad. Yük Çıkış	Servis Faktörü	Tipi	Anma Akımı	Ağırlık	Ölçü Sayfası	Fiyat Kodu
Power	Output Speeds	Output Torque	Ratio	Per.O. Loads (Output)	Service Factors	Type	Rated Current	Weight	Dim. Page	Price Ref.
Leistung P _g [kW] P _g [HP]	Abtriebswelle Drehzahlen n ₂ [r.p.m]	Abtriebswelle Drehmomente M ₂ [Nm]	Übersetzung i	Zul.Querkräfte (Abtrieb) F _{qam} [N]	Betriebsfaktor f _s	Typ	Nennstrom [A]	Gewicht ~ [kg]	Maße Seite	Preis No.
0,18 0,25	0,24	6132	3814,39	55325	1,3	MR775-71/6a	0,61	255	125	MR405
	0,29	5004	3103,85	58620	1,6	NR775-71/6a		315		NR405
	0,34	4319	2684,10	60366	1,9					
	0,39	3744	2324,10	61720	2,1					
	0,44	3277	2032,66	62744	2,4					
	0,50	2891	1791,91	63542	2,8					
	0,57	2567	1589,68	64179	3,1					
	0,63	2290	1417,41	64789	3,5					
	0,72	2027	1252,60	65282	3,9					
	0,31	4523	2863,86	25026	1,0	MR676-71/6a NR676-71/6a	0,61	238 247	122	MR406 NR406
	0,35	4159	2578,93	27204	1,0	MR675-71/6a	0,61	228	122	MR407
	0,41	3536	2196,86	30417	1,2	NR675-71/6a		242		NR407
0,48	3043	1888,53	32546	1,4						
0,55	2643	1638,93	34152	1,6						
0,63	2312	1432,74	35318	1,9						
0,71	2034	1259,54	36200	2,1						
0,81	1801	1113,08	36968	2,4						
0,90	1612	995,91	37525	2,7						
1,0	1418	874,56	38071	3,0						
1,2	1187	730,46	38688	3,6						
0,49	2889	2850,22	20466	1,0	MR576-63/4b NR576-63/4b	0,60	160 153	119	MR408 NR408	
0,51	2828	2736,94	20831	1,1	MR575-63/4b	0,60	152	119	MR409	
0,61	2392	2313,18	23153	1,3	NR575-63/4b		148		NR409	
0,74	1961	1897,20	25085	1,5						
0,84	1733	1675,43	26009	1,7						
0,94	1541	1489,14	26691	1,9						
1,1	1305	1259,61	27489	2,3						
1,2	1184	1140,65	27867	2,5						
1,6	954	574,90	28543	3,1	MR574-71/6a	0,61	135	118	MR410	
1,9	807	485,89	28992	3,7	NR574-71/6a		133		NR410	
2,2	670	402,12	29334	4,0						
0,81	1804	1738,98	11081	0,9	MR475-63/4b	0,60	111	116	MR016	
0,86	1693	1631,08	13214	0,9	NR475-63/4b		115		NR016	
1,0	1441	1386,75	17001	1,1						
1,1	1339	1285,79	18231	1,2						
1,2	1253	1204,49	19174	1,2						
1,3	1119	674,46	20517	1,4	MR474-71/6a	0,61	94	115	MR017	
1,5	1001	603,46	21579	1,5	NR474-71/6a		98		NR017	
1,7	880	529,93	22559	1,8						
2,0	736	442,61	23617	2,1						
2,2	696	418,16	23900	2,2						
2,6	577	346,07	24656	2,7						
3,0	494	295,98	25177	3,1						
1,4	1022	987,33	7515	0,8	MR375-63/4b	0,60	76	113	MR018	
1,7	877	845,97	10731	0,9	NR375-63/4b		81		NR018	



Motorlu Güç Devir Sayfaları

Geared Motors Performance Tables

Leistung und Drehzahlübersicht von Getriebemotoren



Güç	Çıkış Devri	Çıkış Momenti	Çevrim Oranı	Güv. Rad. Yük Çıkış	Servis Faktörü	Tipi	Anma Akımı	Ağırlık	Ölçü Sayfası	Fiyat Kodu
Power	Output Speeds	Output Torque	Ratio	Per.O. Loads (Output)	Service Factors	Type	Rated Current	Weight	Dim. Page	Price Ref.
Leistung P _g [kW] P _g [HP]	Abtriebswelle Drehzahlen n ₂ [r.p.m]	Abtriebswelle Drehmomente M ₂ [Nm]	Übersetzung i	Zul.Querkräfte (Abtrieb) F _{qam} [N]	Betriebsfaktor f _s	Typ	Nennstrom [A]	Gewicht ~ [kg]	Maße Seite	Preis No.
0,18 0,25	1,7	867	524,07	10899	0,9	MR374-71/6a	0,61	58	112	MR019
	2,1	698	421,85	13419	1,2	NR374-71/6a		61		NR019
	2,4	613	369,93	14433	1,3					
	2,7	558	524,07	15060	1,5	MR374-63/4b	0,60	55	112	MR020
	3,3	449	421,85	16080	1,8	NR374-63/4b		58		NR020
	3,8	394	369,93	16545	2,1					
	5,7	280	157,76	16612	2,9	MR373-71/6a	0,61	54	111	MR021
	6,5	246	138,72	15997	3,3	NR373-71/6a		57		NR021
	2,1	715	431,18	6617	0,8	MR284-71/6a	0,61	62	109	MR022
	2,4	611	368,77	9042	1,0	NR284-71/6a		65		NR022
	2,8	536	323,39	10374	1,1					
	3,2	459	431,18	11525	1,3	MR284-63/4b	0,60	60	109	MR023
	3,8	393	368,77	12359	1,5	NR284-63/4b		63		NR023
	4,3	345	323,39	12886	1,7					
	4,9	305	285,89	13313	2,0					
	5,8	257	240,47	13658	2,3					
	6,5	245	137,91	13228	2,4	MR283-71/6a	0,61	40	108	MR024
	7,9	203	114,14	12532	3,0	NR283-71/6a		42		NR024
	2,8	519	499,32	6.196	0,9	MR275-63/4b	0,60	41	107	MR025
	3,3	435	418,57	6.857	1,0	NR275-63/4b		43		NR025
	3,9	373	358,33	7.277	1,2					
	4,2	347	332,52	7.439	1,3					
	5,6	263	252,20	7.904	1,7					
	6,5	246	138,55	7.988	1,8	MR273-71/6a	0,61	30	106	MR026
	7,4	215	121,03	8.133	2,1	NR273-71/6a		32		NR026
	7,9	202	113,52	8.195	2,2					
	9,3	172	96,52	8.324	2,6					
	10	158	138,55	8.388	2,8	MR273-63/4b	0,60	28	106	MR027
	12	138	121,03	8.461	3,3	NR273-63/4b		30		NR027
	13	130	113,52	8.490	3,5					
	13	121	68,03	8463	2,3	MR203-71/6a	0,61	28	105	MR028
	15	106	59,43	8501	2,6	NR203-71/6a		30		NR028
	16	99	55,74	8427	2,8					
	21	78	68,03	7840	3,6	MR203-63/4b	0,60	27	105	MR029
						NR203-63/4b		29		NR029
	9,1	176	99,21	5799	1,1	MR173-71/6a	0,61	16	104	MR030
	10	156	87,60	5900	1,3	NR173-71/6a		18		NR030
	11	146	81,82	5846	1,4					
	13	123	69,16	5613	1,6					
	14	113	99,21	5501	1,8	MR173-63/4b	0,60	13	104	MR031
	16	100	87,60	5328	2,0	NR173-63/4b		15		NR031
	17	93	81,82	5234	2,1					



Motorlu Güç Devir Sayfaları

Geared Motors Performance Tables

Leistung und Drehzahlübersicht von Getriebemotoren

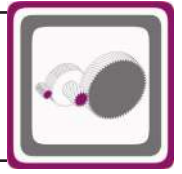

Güç	Çıkış Devri	Çıkış Momenti	Çevrim Oranı	Güv. Rad. Yük Çıkış	Servis Faktörü	Tipi	Anma Akımı	Ağırlık	Ölçü Sayfası	Fiyat Kodu
Power	Output Speeds	Output Torque	Ratio	Per.O. Loads (Output)	Service Factors	Type	Rated Current	Weight	Dim. Page	Price Ref.
Leistung P _g [kW] P _g [HP]	Abtriebswelle Drehzahlen n ₂ [r.p.m]	Abtriebswelle Drehmomente M ₂ [Nm]	Übersetzung i	Zul.Querkräfte (Abtrieb) F _{qam} [N]	Betriebsfaktor f _s	Typ	Nennstrom [A]	Gewicht ~ [kg]	Maße Seite	Preis No.
0,18 0,25	20	79	69,16	5004	2,5	MR173-63/4b	0,60	13	104	MR031
	24	66	57,76	4762	3,0	NR173-63/4b		15		NR031
	28	57	49,81	4567	3,5					
	18	90	50,51	3538	1,6	MR103-71/6a	0,61	15	103	MR032
	20	80	44,60	3437	1,8	NR103-71/6a		17		NR032
	22	74	41,66	3382	1,9					
	28	58	50,51	3177	2,4	MR103-63/4b	0,60	16	103	MR033
	31	51	44,60	3076	2,7	NR103-63/4b		18		NR033
	34	48	41,66	3021	2,9					
	40	40	35,21	2886	3,5					
	20	80	45,18	2507	1,0	MR003-71/6a	0,61	14	102	MR034
	22	71	40,04	2585	1,2	NR003-71/6a		15		NR034
	28	57	32,02	2691	1,4					
	31	51	45,18	2730	1,6	MR003-63/4b	0,60	13	102	MR035
	35	46	40,04	2770	1,8	NR003-63/4b		14		NR035
	44	36	32,02	2818	2,2					
	49	32	28,38	2772	2,5					
	58	28	24,13	2717	3,0					
	66	24	21,26	2646	3,4					
	68	24	20,66	2654	3,5					
	73	22	19,17	2587	3,7					
	77	21	18,20	2544	3,9					
	83	19	16,89	2477	4,0					
	95	17	14,67	2361	4,0					
	103	16	13,61	2300	4,0					
	126	13	11,14	2162	4,0	MR002-63/4b	0,60	12	102	MR036
	142	11	9,87	2073	4,0	NR002-63/4b		13		NR036
	161	10	8,70	1983	4,0					
	166	10	8,45	1962	4,0					
	179	9	7,84	1910	4,0					
	188	9	7,45	1878	4,0					
	203	8	6,91	1829	4,0					
	233	7	6,00	1743	4,0					
	251	6	5,57	1698	4,0					
	307	5	4,56	1587	4,0					
	359	5	3,90	1504	4,0					
	387	4	3,62	1465	4,0					
	405	4	6,91	1437	4,0	MR002-63/2a	0,50	12	102	MR037
	467	3	6,00	1370	4,0	NR002-63/2a		13		NR037
	503	3	5,57	1335	4,0					
615	3	4,56	1248	4,0						
718	2	3,90	1184	4,0						
774	2	3,62	1154	4,0						
0,25 0,34	0,12	16352	11443,34	47139	0,8	MR876-71/4a	0,81	610	128	MR038
	0,17	11945	8345,18	78313	1,1	NR876-71/4a		625		NR038
	0,19	10332	7233,00	86091	1,3					
	0,22	9027	6313,78	91518	1,4					
	0,25	7969	5569,66	95396	1,6					
	0,28	7094	4954,95	98545	1,8					
	0,32	6358	4438,59	100925	2,0					
	0,36	5584	3892,30	103268	2,3					



Motorlu Güç Devir Sayfaları

Geared Motors Performance Tables

Leistung und Drehzahlübersicht von Getriebemotoren

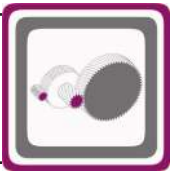

Güç	Çıkış Devri	Çıkış Momenti	Çevrim Oranı	Güv. Rad. Yük Çıkış	Servis Faktörü	Tipi	Anma Akımı	Ağırlık	Ölçü Sayfası	Fiyat Kodu
Power	Output Speeds	Output Torque	Ratio	Per.O. Loads (Output)	Service Factors	Type	Rated Current	Weight	Dim. Page	Price Ref.
Leistung P _g [kW] P _g [HP]	Abtriebswelle Drehzahlen n ₂ [r.p.m]	Abtriebswelle Drehmomente M ₂ [Nm]	Übersetzung i	Zul.Querkräfte (Abtrieb) F _{qam} [N]	Betriebsfaktor f _s	Typ	Nennstrom [A]	Gewicht ~ [kg]	Maße Seite	Preis No.
0,25 0,34	0,41	4944	3441,02	105090	2,6	MR876-71/4a	0,81	610	128	MR038
	0,48	4167	2894,28	107163	3,1	NR876-71/4a		625		NR038
	0,57	3549	2460,65	108704	3,7					
	0,66	3046	2108,33	109889	4,0					
	0,24	8508	5949,83	46821	0,9	MR776-71/4a	0,81	258	125	MR411
	0,27	7533	5260,00	50676	1,1	NR776-71/4a		320		NR411
	0,29	7049	4812,09	52395	1,1	MR775-71/4a	0,81	255	125	MR412
	0,33	6245	4263,81	54986	1,3	NR775-71/4a		316		NR412
	0,37	5591	3814,39	56998	1,4					
	0,45	4562	3103,85	59765	1,8					
	0,52	3938	2684,10	61275	2,0					
	0,60	3413	2324,10	62452	2,3					
0,69	2988	2032,66	63346	2,7						
0,78	2636	1791,91	64046	3,0						
0,88	2340	1589,68	64693	3,4						
0,99	2087	1417,41	65170	3,8						
1,1	1848	1252,60	65609	4,0						
0,42	4805	3342,43	23089	0,9	MR676-71/4a	0,81	230	122	MR413	
0,49	4124	2863,86	27402	1,0	NR676-71/4a		242		NR413	
0,54	3792	2578,93	29170	1,1	MR675-71/4a	0,81	228	122	MR414	
0,64	3224	2196,86	31808	1,3	NR675-71/4a		243		NR414	
0,74	2774	1888,53	33656	1,5						
0,85	2410	1638,93	34935	1,8						
0,98	2108	1432,74	35973	2,0						
1,1	1855	1259,54	36805	2,3						
1,3	1642	1113,08	37438	2,6						
1,4	1469	995,91	37928	2,9						
1,6	1293	874,56	38410	3,3						
1,9	1082	730,46	38957	4,0						
0,74	2781	1897,20	21134	1,1	MR575-71/4a	0,81	151	119	MR415	
0,84	2458	1675,43	22834	1,2	NR575-71/4a		147		NR415	
0,94	2186	1489,14	24122	1,4						
1,1	1850	1259,61	25531	1,6						
1,2	1680	1140,65	26185	1,8						
1,6	1353	574,90	27325	2,2	MR574-71/6b	0,83	137	118	MR416	
1,9	1145	485,89	27982	2,6	NR574-71/6b		133		NR416	
2,2	950	402,12	28571	3,2						
2,4	870	574,90	28808	3,5	MR574-71/4a	0,81	132	118	MR417	
2,9	736	485,89	29182	4,0	NR574-71/4a		128		NR417	
1,1	1898	1285,79	8731	0,8	MR475-71/4a	0,81	100	116	MR045	
1,2	1777	1204,49	11638	0,9	NR475-71/4a		105		NR045	
1,3	1587	674,46	14952	1,0	MR474-71/6b	0,83	95	115	MR046	
1,5	1419	603,46	17270	1,1	NR474-71/6b		100		NR046	
1,7	1248	529,93	19226	1,2						
2,0	1044	442,61	21195	1,5						



Motorlu Güç Devir Sayfaları

Geared Motors Performance Tables

Leistung und Drehzahlübersicht von Getriebemotoren

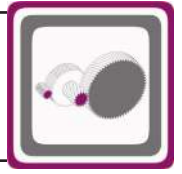

Güç	Çıkış Devri	Çıkış Momenti	Çevrim Oranı	Güv. Rad. Yük Çıkış	Servis Faktörü	Tipi	Anma Akımı	Ağırlık	Ölçü Sayfası	Fiyat Kodu
Power	Output Speeds	Output Torque	Ratio	Per.O. Loads (Output)	Service Factors	Type	Rated Current	Weight	Dim. Page	Price Ref.
Leistung P _g [kW] P _g [HP]	Abtriebswelle Drehzahlen n ₂ [r.p.m]	Abtriebswelle Drehmomente M ₂ [Nm]	Übersetzung i	Zul.Querkräfte (Abtrieb) F _{qam} [N]	Betriebsfaktor f _s	Typ	Nennstrom [A]	Gewicht ~ [kg]	Maße Seite	Preis No.
0,25 0,34	2,1	1020	674,46	21400	1,5	MR474-71/4a	0,81	95	115	MR047
	2,3	912	603,46	22299	1,7	NR474-71/4a		100		NR047
	2,6	802	529,93	23156	1,9					
	3,2	671	442,61	24046	2,3					
	3,3	634	418,16	24302	2,4					
	4,0	526	346,07	24977	2,9					
	2,1	990	421,85	8390	0,8	MR374-71/6b	0,83	58	112	MR048
	2,4	869	369,93	10865	0,9	NR374-71/6b		63		NR048
	2,7	791	524,07	12141	1,0	MR374-71/4a	0,81	58	112	MR049
	3,3	637	421,85	14175	1,3	NR374-71/4a		63		NR049
	3,8	559	369,93	15022	1,5					
	4,3	495	327,04	15661	1,7					
	5,1	416	275,08	16358	2,0					
	5,7	390	157,76	16204	2,1	MR373-71/6b	0,83	58	111	MR050
	6,5	343	138,72	15639	2,4	NR373-71/6b		63		NR050
	8,1	276	111,67	14708	3,0					
	8,9	251	157,76	14306	3,3	MR373-71/4a	0,81	52	111	MR051
						NR373-71/4a		57		NR051
	2,4	866	368,77	-	0,7	MR284-71/6b	0,83	62	109	MR052
	2,8	761	323,39	5008	0,8	NR284-71/6b		65		NR052
	3,2	651	431,18	8204	0,9	MR284-71/4a	0,81	62	109	MR053
	3,8	557	368,77	10030	1,1	NR284-71/4a		65		NR053
	4,3	489	323,39	11099	1,2					
	4,9	433	285,89	11849	1,4					
	5,8	364	240,47	12678	1,6					
	6,5	341	137,91	12835	1,8	MR283-71/6b	0,83	30	108	MR054
	7,9	283	114,14	12207	2,1	NR283-71/6b		32		NR054
	9,2	242	97,62	11696	2,5					
	10	219	137,91	11387	2,7	MR283-71/4a	0,81	30	108	MR055
	12	182	114,14	10791	3,3	NR283-71/4a		32		NR055
	3,9	529	358,33	6.097	0,9	MR275-71/4a	0,81	45	107	MR056
	4,2	492	332,52	6.422	0,9	NR275-71/4a		47		NR056
	5,6	373	252,20	7.281	1,2					
	6,5	343	138,55	7.465	1,3	MR273-71/6b	0,83	30	106	MR057
	7,4	300	121,03	7.711	1,5	NR273-71/6b		32		NR057
	7,9	281	113,52	7.802	1,6					
	9,3	239	96,52	8.021	1,9					
	10	220	138,55	8.110	2,0	MR273-71/4a	0,81	30	106	MR058
	12	193	121,03	8.238	2,3	NR273-71/4a		32		NR058
	13	181	113,52	8.287	2,5					
	15	154	96,52	8.400	2,9					
	17	134	83,83	8.475	3,4					



Motorlu Güç Devir Sayfaları

Geared Motors Performance Tables

Leistung und Drehzahlübersicht von Getriebemotoren



Güç	Çıkış Devri	Çıkış Momenti	Çevrim Oranı	Güv. Rad. Yük Çıkış	Servis Faktörü	Tipi	Anma Akımı	Ağırlık	Ölçü Sayfası	Fiyat Kodu
Power	Output Speeds	Output Torque	Ratio	Per.O. Loads (Output)	Service Factors	Type	Rated Current	Weight	Dim. Page	Price Ref.
Leistung P _g [kW] P _g [HP]	Abtriebswelle Drehzahlen n ₂ [r.p.m]	Abtriebswelle Drehmomente M ₂ [Nm]	Übersetzung i	Zul.Querkräfte (Abtrieb) F _{qam} [N]	Betriebsfaktor f _s	Typ	Nennstrom [A]	Gewicht ~ [kg]	Maße Seite	Preis No.
0,25 0,34	13	169	68,03	8300	1,7	MR203-71/6b	0,83	28	105	MR059
	15	148	59,43	8381	1,9	NR203-71/6b		30		NR059
	16	138	55,74	8234	2,0					
	21	108	68,03	7689	2,6	MR203-71/4a	0,81	28	105	MR060
	24	95	59,43	7395	3,0	NR203-71/4a		30		NR060
	25	89	55,74	7258	3,1					
	30	76	47,39	6919	3,7					
	9,1	245	99,21	5390	0,8	MR173-71/6b	0,83	17	104	MR061
	10	217	87,60	5574	0,9	NR173-71/6b		19		NR061
	14	158	99,21	5241	1,3	MR173-71/4a	0,81	18	104	MR062
	16	139	87,60	5099	1,4	NR173-71/4a		19		NR062
	17	130	81,82	5020	1,5					
	20	110	69,16	4823	1,8					
	24	92	57,76	4611	2,2					
	28	79	49,81	4437	2,5					
	31	73	45,90	4342	2,7					
	33	68	42,87	4263	2,9					
	39	58	36,24	4070	3,5					
	18	125	50,51	3320	1,1	MR103-71/6b	0,83	17	103	MR063
	20	111	44,60	3244	1,3	NR103-71/6b		19		NR063
	22	103	41,66	3201	1,4					
	28	80	50,51	3037	1,7	MR103-71/4a	0,81	16	103	MR064
	31	71	44,60	2952	2,0	NR103-71/4a		17		NR064
	34	67	41,66	2905	2,1					
	40	56	35,21	2788	2,5					
	43	52	32,25	2727	2,7					
	48	47	29,40	2663	3,0					
	56	40	24,86	2519	3,3					
	20	111	45,18	1844	0,7	MR003-71/6b	0,83	13	102	MR065
	22	99	40,04	1969	0,8	NR003-71/6b		14		NR065
	28	79	32,02	2224	1,0					
	31	72	45,18	2290	1,1	MR003-71/4a	0,81	12	102	MR066
	35	64	40,04	2326	1,3	NR003-71/4a		13		NR066
	44	51	32,02	2414	1,6					
	49	45	28,38	2409	1,8					
	58	38	24,13	2408	2,1					
	66	34	21,26	2367	2,4					
	68	33	20,66	2389	2,5					
	73	31	19,17	2375	2,7					
	77	29	18,20	2341	2,8					
	83	27	16,89	2324	3,0					
	95	23	14,67	2255	3,5					
	103	22	13,61	2233	3,7					
	126	18	11,14	2192	3,6	MR002-71/4a	0,81	12	102	MR067
	142	16	9,87	2099	4,0	NR002-71/4a		13		NR067
	161	14	8,70	2008	4,0					
	166	14	8,45	1984	4,0					
	179	13	7,84	1932	4,0					
	188	12	7,45	1898	4,0					
	203	11	6,91	1848	4,0					



Motorlu Güç Devir Sayfaları

Geared Motors Performance Tables

Leistung und Drehzahlübersicht von Getriebemotoren

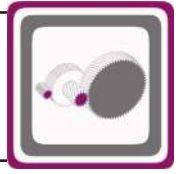

Güç	Çıkış Devri	Çıkış Momenti	Çevrim Oranı	Güv. Rad. Yük Çıkış	Servis Faktörü	Tipi	Anma Akımı	Ağırlık	Ölçü Sayfası	Fiyat Kodu			
Power	Output Speeds	Output Torque	Ratio	Per.O. Loads (Output)	Service Factors	Type	Rated Current	Weight	Dim. Page	Price Ref.			
Leistung P _g [kW] P _g [HP]	Abtriebswelle Drehzahlen n ₂ [r.p.m]	Abtriebswelle Drehmomente M ₂ [Nm]	Übersetzung i	Zul.Querkräfte (Abtrieb) F _{qam} [N]	Betriebsfaktor f _s	Typ	Nennstrom [A]	Gewicht ~ [kg]	Maße Seite	Preis No.			
0,25 0,34	233	10	6,00	1760	4,0	MR002-71/4a	0,81	12	102	MR067 NR067			
	251	9	5,57	1714	4,0	NR002-71/4a		13					
	307	7	4,56	1602	4,0								
	359	6	3,90	1517	4,0								
	387	6	3,62	1477	4,0								
	405	6	6,91	1447	4,0	MR002-63/2b	0,67	13	102	MR068 NR068			
	467	5	6,00	1379	4,0	NR002-63/2b		14					
	503	4	5,57	1343	4,0								
	615	4	4,56	1256	4,0								
	718	3	3,90	1190	4,0								
	774	3	3,62	1160	4,0								
	0,37 0,50	0,19	15764	7233,00	52556	0,8	MR876-71/4b	1,15	598	128	MR069		
		0,22	13773	6313,78	67696	0,9	NR876-71/4b		610				
		0,25	12159	5569,66	77181	1,1							
0,28		10823	4954,95	83854	1,2								
0,32		9700	4438,59	88809	1,3								
0,36		8520	3892,30	93432	1,5								
0,41		7544	3441,02	97015	1,7								
0,48		6358	2894,28	100924	2,0								
0,57		5415	2460,65	103759	2,4								
0,66		4648	2108,33	105897	2,8								
0,73		4328	1924,32	106745	3,0	MR875-71/4b	1,15	595	128	MR070 NR070			
0,82		3831	1700,56	108012	3,4	NR875-71/4b		605					
0,92		3428	1521,55	108994	3,8								
0,37		8530	3814,39	46727	0,9	MR775-71/4b	1,15	263	125	MR418 NR418			
0,45		6960	3103,85	52696	1,1	NR775-71/4b		321					
0,52		6008	2684,10	55691	1,3								
0,60		5208	2324,10	58071	1,5								
0,69		4558	2032,66	59774	1,8								
0,78		4022	1791,91	61080	2,0								
0,88		3570	1589,68	62109	2,2								
0,99		3185	1417,41	62938	2,5								
1,1		2820	1252,60	63685	2,8								
1,2		2524	1120,74	64261	3,2								
1,4		2220	984,18	64921	3,6								
1,5		2141	594,92	65069	3,7	MR774-80/6a		1,10			243	124	MR419 NR419
1,7		1916	532,29	65485	4,0	NR774-80/6a					300		
0,74		4233	1888,53	26785	1,0	MR675-71/4b		1,15			227	122	MR420 NR420
0,85		3677	1638,93	29744	1,2	NR675-71/4b	243						
0,98		3217	1432,74	31839	1,3								
1,1		2830	1259,54	33442	1,5								
1,3		2505	1113,08	34659	1,7								
1,4		2242	995,91	35549	1,9								
1,6		1972	874,56	36387	2,2								
1,8		1801	500,39	36969	2,4	MR674-80/6a	1,10	217	121	MR421 NR421			
2,0		1594	442,20	37577	2,7	NR674-80/6a		233					
2,4	1356	376,69	38240	3,2									
2,8	1167	323,82	38740	3,7									
3,2	1014	281,02	39128	4,0									



Motorlu Güç Devir Sayfaları

Geared Motors Performance Tables

Leistung und Drehzahlübersicht von Getriebemotoren

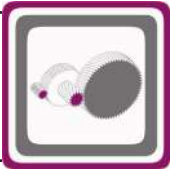

Güç	Çıkış Devri	Çıkış Momenti	Çevrim Oranı	Güv. Rad. Yük Çıkış	Servis Faktörü	Tipi	Anma Akımı	Ağırlık	Ölçü Sayfası	Fiyat Kodu
Power	Output Speeds	Output Torque	Ratio	Per.O. Loads (Output)	Service Factors	Type	Rated Current	Weight	Dim. Page	Price Ref.
Leistung P _g [kW] P _g [HP]	Abtriebswelle Drehzahlen n ₂ [r.p.m]	Abtriebswelle Drehmomente M ₂ [Nm]	Übersetzung i	Zul.Querkräfte (Abtrieb) F _{qam} [N]	Betriebsfaktor f _s	Typ	Nennstrom [A]	Gewicht ~ [kg]	Maße Seite	Preis No.
0,37 0,50	1,1	2823	1259,61	20859	1,1	MR575-71/4b	1,15	151	119	MR422
	1,2	2563	1140,65	22299	1,2	NR575-71/4b		148		NR422
	1,5	2168	964,05	24194	1,4					
	1,6	2064	574,90	24650	1,5	MR574-80/6a	1,10	137	118	MR423
	1,9	1747	485,89	25930	1,7	NR574-80/6a		133		NR423
	2,2	1449	402,12	27005	2,1					
	2,4	1327	574,90	27421	2,3	MR574-71/4b	1,15	132	118	MR424
	2,9	1123	485,89	28074	2,7	NR574-71/4b		128		NR424
	3,5	931	402,12	28679	3,2					
	4,1	797	343,91	29031	3,8					
	4,6	700	301,59	29283	4,0					
	4,8	675	291,25	29347	4,0					
	1,7	1904	529,93	8618	0,8	MR474-80/6a	1,10	135	115	MR077
	2,0	1593	442,61	14843	1,0	NR474-80/6a		140		NR077
	2,1	1557	674,46	15399	1,0	MR474-71/4b	1,15	130	115	MR078
	2,3	1392	603,46	17638	1,1	NR474-71/4b		135		NR078
	2,6	1224	529,93	19503	1,3					
	3,2	1024	442,61	21375	1,5					
	3,3	968	418,16	21849	1,6					
	4,0	803	346,07	23137	1,9					
	4,1	802	219,00	23145	1,9	MR473-80/6a	1,10	85	114	MR079
	4,6	710	194,05	23820	2,2	NR473-80/6a		88		NR079
	5,7	579	157,90	24655	2,7					
	6,4	512	139,54	25068	3,0					
	7,2	458	124,85	25377	3,4					
	3,3	971	421,85	8839	0,8	MR374-71/4b	1,15	58	112	MR080
	3,8	853	369,93	11153	1,0	NR374-71/4b		63		NR080
	4,3	755	327,04	12665	1,1					
	5,1	635	275,08	14178	1,3					
	5,7	577	157,76	14828	1,4	MR373-80/6a	1,10	63	111	MR081
	6,5	507	138,72	15025	1,6	NR373-80/6a		68		NR081
	8,1	409	111,67	14214	2,0					
	8,9	372	157,76	13857	2,2	MR373-71/4b	1,15	52	111	MR082
	10	327	138,72	13384	2,5	NR373-71/4b		57		NR082
	13	264	111,67	12603	3,1					
	14	231	97,92	12142	3,5					
	4,9	660	285,89	8020	0,9	MR284-71/4b	1,15	62	109	MR083
						NR284-71/4b		65		NR083
	6,5	504	137,91	10851	1,2	MR283-80/6a	1,10	42	108	MR084
	7,9	418	114,14	11649	1,4	NR283-80/6a		44		NR084
	9,2	358	97,62	11219	1,7					
	10	325	137,91	10953	1,8	MR283-71/4b	1,15	38	108	MR085
	12	270	114,14	10432	2,2	NR283-71/4b		41		NR085
	14	231	97,62	10006	2,6					



Motorlu Güç Devir Sayfaları

Geared Motors Performance Tables

Leistung und Drehzahlübersicht von Getriebemotoren

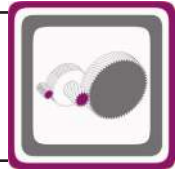

Güç	Çıkış Devri	Çıkış Momenti	Çevrim Oranı	Güv. Rad. Yük Çıkış	Servis Faktörü	Tipi	Anma Akımı	Ağırlık	Ölçü Sayfası	Fiyat Kodu
Power	Output Speeds	Output Torque	Ratio	Per.O. Loads (Output)	Service Factors	Type	Rated Current	Weight	Dim. Page	Price Ref.
Leistung P _g [kW] P _g [HP]	Abtriebswelle Drehzahlen n ₂ [r.p.m]	Abtriebswelle Drehmomente M ₂ [Nm]	Übersetzung i	Zul.Querkräfte (Abtrieb) F _{qam} [N]	Betriebsfaktor f _s	Typ	Nennstrom [A]	Gewicht ~ [kg]	Maße Seite	Preis No.
0,37 0,50	16	202	85,60	9654	3,0	MR283-71/4b NR283-71/4b	1,15	38 41	108	MR085 NR085
	6,5	507	138,55	6.295	0,9	MR273-80/6a	1,10	30	106	MR086
	7,4	443	121,03	6.799	1,0	NR273-80/6a		33		NR086
	7,9	416	113,52	6.994	1,1					
	9,3	354	96,52	7.399	1,3					
	10	327	138,55	7.558	1,4	MR273-71/4b	1,15	28	106	MR087
	11	286	121,03	7.785	1,6	NR273-71/4b		31		NR087
	12	268	113,52	7.884	1,7					
	15	228	96,52	8.074	2,0					
	17	198	83,83	8.210	2,3					
19	174	73,35	8.316	2,6						
23	144	60,66	7.857	3,1						
	13	249	68,03	7966	1,1	MR203-80/6a	1,10	35	105	MR088
	15	218	59,43	8029	1,3	NR203-80/6a		37		NR088
	16	205	55,74	7904	1,4					
	21	161	68,03	7430	1,7	MR203-71/4b	1,15	33	105	MR089
	24	141	59,43	7168	2,0	NR203-71/4b		36		NR089
	25	132	55,74	7046	2,1					
	30	112	47,39	6738	2,5					
	32	104	43,94	6597	2,7					
	34	98	41,16	6477	2,9					
	39	86	36,02	6234	3,3					
	14	234	99,21	4796	0,9	MR173-71/4b	1,15	18	104	MR090
	16	207	87,60	4706	1,0	NR173-71/4b		19		NR090
	17	193	81,82	4653	1,0					
	20	163	69,16	4513	1,2					
	24	137	57,76	4352	1,5					
	28	118	49,81	4214	1,7					
	31	109	45,90	4136	1,8					
	33	102	42,87	4070	2,0					
	39	86	36,24	3908	2,3					
	46	72	30,26	3734	2,8					
	54	62	26,10	3591	3,2					
	18	185	50,51	2945	0,8	MR103-80/6a	1,10	20	103	MR091
	20	164	44,60	2913	0,9	NR103-80/6a		22		NR091
	22	153	41,66	2892	0,9					
	28	120	50,51	2796	1,2	MR103-71/4b	1,15	17	103	MR092
	31	106	44,60	2739	1,3	NR103-71/4b		18		NR092
	34	99	41,66	2706	1,4					
	40	84	35,21	2620	1,7					
	43	77	32,25	2573	1,8					
	48	70	29,40	2522	2,0					
	56	59	24,86	2387	2,2					
	64	52	21,96	2321	2,3					
	68	49	20,51	2285	2,5					
	81	41	17,33	2194	2,7					
		88	38	15,95	2175	3,0	MR102-71/4b	1,15	17	103
99		34	14,08	2105	3,2	NR102-71/4b		18		NR093



Motorlu Güç Devir Sayfaları

Geared Motors Performance Tables

Leistung und Drehzahlübersicht von Getriebemotoren

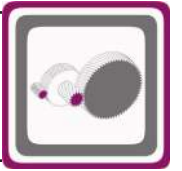

Güç	Çıkış Devri	Çıkış Momenti	Çevrim Oranı	Güv. Rad. Yük Çıkış	Servis Faktörü	Tipi	Anma Akımı	Ağırlık	Ölçü Sayfası	Fiyat Kodu	
Power	Output Speeds	Output Torque	Ratio	Per.O. Loads (Output)	Service Factors	Type	Rated Current	Weight	Dim. Page	Price Ref.	
Leistung P _g [kW] P _g [HP]	Abtriebswelle Drehzahlen n ₂ [r.p.m]	Abtriebswelle Drehmomente M ₂ [Nm]	Übersetzung i	Zul.Querkräfte (Abtrieb) F _{qam} [N]	Betriebsfaktor f _s	Typ	Nennstrom [A]	Gewicht ~ [kg]	Maße Seite	Preis No.	
0,37 0,50	106	31,7	13,15	2066	3,3	MR102-71/4b NR102-71/4b	1,15	17 18	103	MR093 NR093	
	31	106	45,18	1312	0,8	MR003-71/4b	1,15	13	102	MR094	
	35	94	40,04	1448	0,9	NR003-71/4b		14		NR094	
	44	76	32,02	1721	1,1						
	49	67	28,38	1786	1,2						
	58	57	24,13	1879	1,4						
	66	50	21,26	1888	1,6						
	68	49	20,66	1936	1,7						
	73	46	19,17	1955	1,8						
	77	43	18,20	1931	1,9						
	83	40	16,89	1943	2,0						
	95	35	14,67	1910	2,4						
	103	32	13,61	1913	2,5						
		126	27	11,14	2091	2,4	MR002-71/4b	1,15	13	102	MR095
		142	24	9,87	2046	3,3	NR002-71/4b		14		NR095
		161	21	8,70	1989	3,5					
		166	20	8,45	1995	3,6					
		179	19	7,84	1968	3,8					
		188	18	7,45	1933	4,0					
		203	17	6,91	1881	4,0					
		233	15	6,00	1790	4,0					
		251	13	5,57	1741	4,0					
		307	11	4,56	1628	4,0					
		359	9	3,90	1539	4,0					
		387	9	3,62	1498	4,0					
		405	8	6,91	1463	4,0	MR002-71/2a	1,05	13	102	MR096
		467	7	6,00	1394	4,0	NR002-71/2a		14		NR096
		503	7	5,57	1357	4,0					
		615	6	4,56	1269	4,0					
		718	5	3,90	1201	4,0					
		774	4	3,62	1170	4,0					
	0,55 0,75	0,20	22315	6842,29	60646	0,8	MR976-80/4a	1,60	1100	131	MR365
		0,26	17510	5357,43	97965	1,0	NR976-80/4a		1150		NR365
		0,31	14657	4474,67	113064	1,2					
		0,33	13857	4227,50	116743	1,3					
		0,39	11799	3594,81	125182	1,5					
		0,49	9341	2836,64	134198	1,9					
		0,69	6811	2027,97	142037	2,6	MR975-80/4a	1,60	1098	131	MR366
		0,77	6119	1820,78	143981	2,9	NR975-80/4a		1148		NR366
		0,90	5213	1552,10	146403	3,5					
0,28		16089	4954,95	49597	0,8	MR876-80/4a	1,60	600	128	MR097	
0,32		14419	4438,59	63360	0,9	NR876-80/4a		610		NR097	
0,36		12665	3892,30	74393	1,0						
0,41		11213	3441,02	81997	1,2						
0,48		9451	2894,28	89993	1,4						
0,57		8050	2460,65	95115	1,6						
0,66		6909	2108,33	99155	1,9						
0,73		6434	1924,32	100685	2,0	MR875-80/4a	1,60	596	128	MR098	
0,82		5695	1700,56	102942	2,3	NR875-80/4a		606		NR098	
0,92		5096	1521,55	104666	2,6						
1,0		4483	1336,15	106338	2,9						



Motorlu Güç Devir Sayfaları

Geared Motors Performance Tables

Leistung und Drehzahlübersicht von Getriebemotoren

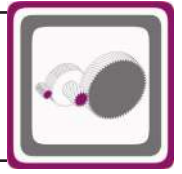

Güç	Çıkış Devri	Çıkış Momenti	Çevrim Oranı	Güv. Rad. Yük Çıkış	Servis Faktörü	Tipi	Anma Akımı	Ağırlık	Ölçü Sayfası	Fiyat Kodu
Power	Output Speeds	Output Torque	Ratio	Per.O. Loads (Output)	Service Factors	Type	Rated Current	Weight	Dim. Page	Price Ref.
Leistung P _g [kW] P _g [HP]	Abtriebswelle Drehzahlen n ₂ [r.p.m]	Abtriebswelle Drehmomente M ₂ [Nm]	Übersetzung i	Zul.Querkräfte (Abtrieb) F _{qam} [N]	Betriebsfaktor f _s	Typ	Nennstrom [A]	Gewicht ~ [kg]	Maße Seite	Preis No.
0,55 0,75	1,2	4064	1210,51	107425	3,2	MR875-80/4a	1,60	596	128	MR098
	1,3	3517	1049,18	108783	3,7	NR875-80/4a		606		NR098
0,60 0,69 0,78 0,88 0,99 1,1 1,2 1,4	0,60	7741	2324,10	49968	1,0	MR775-80/4a	1,60	337	125	MR425
	0,69	6776	2032,66	53310	1,2	NR775-80/4a		412		NR425
	0,78	5978	1791,91	55778	1,3					
	0,88	5307	1589,68	57798	1,5					
	0,99	4735	1417,41	59325	1,7					
	1,1	4191	1252,60	60677	1,9					
	1,2	3751	1120,74	61703	2,1					
	1,4	3300	984,18	62695	2,4					
1,5 1,7 1,9 2,2	1,5	3183	594,92	62942	2,5	MR774-80/6b	1,50	317	124	MR426
	1,7	2849	532,29	63627	2,8	NR774-80/6b		392		NR426
	1,9	2506	467,43	64294	3,2					
	2,2	2244	418,17	64875	3,6					
2,4 2,6	2,4	2046	594,92	65246	3,9	MR774-80/4a	1,60	312	124	MR427
	2,6	1831	532,29	65639	4,0	NR774-80/4a		388		NR427
0,98 1,1 1,3 1,4 1,6	0,98	4781	1432,74	23257	0,9	MR675-80/4a	1,60	242	122	MR428
	1,1	4206	1259,54	26937	1,0	NR675-80/4a		252		NR428
	1,3	3723	1113,08	29513	1,2					
	1,4	3332	995,91	31341	1,3					
	1,6	2932	874,56	32977	1,5					
1,8 2,0 2,4	1,8	2676	500,39	34028	1,6	MR674-80/6b	1,50	222	121	MR429
	2,0	2369	442,20	35159	1,8	NR674-80/6b		232		NR429
	2,4	2016	376,69	36257	2,1					
2,8 3,2 3,7 4,3 5,0	2,8	1721	500,39	37207	2,5	MR674-80/4a	1,60	217	121	MR430
	3,2	1523	442,20	37778	2,8	NR674-80/4a		228		NR430
	3,7	1296	376,69	38402	3,3					
	4,3	1116	323,82	38873	3,9					
	5,0	969	281,02	39240	4,0					
1,6 1,9 2,2	1,6	3068	574,90	19348	1,0	MR574-80/6b	1,50	152	118	MR431
	1,9	2596	485,89	22135	1,2	NR574-80/6b		148		NR431
	2,2	2154	402,12	24257	1,4					
2,4 2,9 3,5 4,1 4,6 4,8 5,4 6,3 7,2	2,4	1972	574,90	25036	1,5	MR574-80/4a	1,60	148	118	MR432
	2,9	1669	485,89	26228	1,8	NR574-80/4a		143		NR432
	3,5	1385	402,12	27265	2,2					
	4,1	1185	343,91	27894	2,5					
	4,6	1041	301,59	28326	2,9					
	4,8	1004	291,25	28435	3,0					
	5,4	893	258,87	28790	3,4					
	6,3	765	221,40	29111	3,9					
7,2	672	194,15	29355	4,0						
2,6 3,2 3,3 4,0	2,6	1820	529,93	10653	0,9	MR474-80/4a	1,60	130	115	MR106
	3,2	1522	442,61	15915	1,0	NR474-80/4a		134		NR106
	3,3	1439	418,16	17031	1,1					
	4,0	1193	346,07	19787	1,3					



Motorlu Güç Devir Sayfaları

Geared Motors Performance Tables

Leistung und Drehzahlübersicht von Getriebemotoren

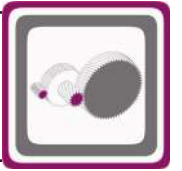

Güç	Çıkış Devri	Çıkış Momenti	Çevrim Oranı	Güv. Rad. Yük Çıkış	Servis Faktörü	Tipi	Anma Akımı	Ağırlık	Ölçü Sayfası	Fiyat Kodu
Power	Output Speeds	Output Torque	Ratio	Per.O. Loads (Output)	Service Factors	Type	Rated Current	Weight	Dim. Page	Price Ref.
Leistung P _g [kW] P _g [HP]	Abtriebswelle Drehzahlen n ₂ [r.p.m]	Abtriebswelle Drehmomente M ₂ [Nm]	Übersetzung i	Zul.Querkräfte (Abtrieb) F _{qam} [N]	Betriebsfaktor f _s	Typ	Nennstrom [A]	Gewicht ~ [kg]	Maße Seite	Preis No.
0,55 0,75	4,1	1195	219,00	19775	1,3	MR473-80/6b	1,50	110	114	MR107
	4,6	1058	194,05	21103	1,5	NR473-80/6b		113		NR107
	5,7	863	157,90	22693	1,8					
	6,4	769	219,00	23341	2,0	MR473-80/4a	1,60	108	114	MR108
	7,2	681	194,05	23993	2,3	NR473-80/4a		111		NR108
	8,9	556	157,90	24667	2,8					
	10	491	139,54	23803	3,2					
	11	440	124,85	23042	3,5					
	5,1	945	275,08	9452	0,9	MR374-80/4a NR374-80/4a	1,60	63 67	112	MR109 NR109
	5,7	859	157,76	11044	1,0	MR373-80/6b	1,50	57	111	MR110
	6,5	756	138,72	12629	1,1	NR373-80/6b		60		NR110
	8,1	609	111,67	13472	1,3					
	8,9	553	157,76	13183	1,5	MR373-80/4a	1,60	63	111	MR111
	10	487	138,72	12792	1,7	NR373-80/4a		67		NR111
	13	392	111,67	12126	2,1					
	14	344	97,92	11724	2,4					
	16	305	86,57	11348	2,7					
	19	257	72,81	10828	3,2					
	23	218	61,91	10350	3,8					
	6,5	751	137,91	5392	0,8	MR283-80/6b	1,50	45	108	MR112
	7,9	623	114,14	8813	1,0	NR283-80/6b		48		NR112
	9,2	533	97,62	10504	1,1					
	10	484	137,91	10304	1,2	MR283-80/4a	1,60	45	108	MR113
	12	401	114,14	9895	1,5	NR283-80/4a		48		NR113
	14	343	97,62	9547	1,7					
	16	301	85,60	9250	2,0					
	18	267	75,68	8971	2,3					
	22	225	63,65	8581	2,7					
	26	191	54,12	8218	3,1					
	9,3	527	96,52	6120	0,9	MR273-80/6b NR273-80/6b	1,50	30 33	106	MR114 NR114
	10	486	138,55	6466	0,9	MR273-80/4a	1,60	30	106	MR115
12	425	121,03	6929	1,1	NR273-80/4a		33		NR115	
	13	399	113,52	7109	1,1					
	15	339	96,52	7479	1,3					
	17	295	83,83	7737	1,5					
	19	258	73,35	7927	1,7					
	23	214	60,66	7999	2,1					
	28	179	50,59	7483	2,5					
	33	150	42,41	7018	3,0					
	38	129	36,55	6651	3,5					
	13	372	68,03	7330	0,8	MR203-80/6b	1,50	33	105	MR116
	15	325	59,43	7500	0,9	NR203-80/6b		34		NR116
16	305	55,74	7408	0,9						



Motorlu Güç Devir Sayfaları

Geared Motors Performance Tables

Leistung und Drehzahlübersicht von Getriebemotoren

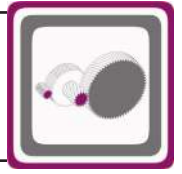

Güç	Çıkış Devri	Çıkış Momenti	Çevrim Oranı	Güv. Rad. Yük Çıkış	Servis Faktörü	Tipi	Anma Akımı	Ağırlık	Ölçü Sayfası	Fiyat Kodu	
Power	Output Speeds	Output Torque	Ratio	Per.O. Loads (Output)	Service Factors	Type	Rated Current	Weight	Dim. Page	Price Ref.	
Leistung P _g [kW] P _g [HP]	Abtriebswelle Drehzahlen n ₂ [r.p.m]	Abtriebswelle Drehmomente M ₂ [Nm]	Übersetzung i	Zul.Querkräfte (Abtrieb) F _{qam} [N]	Betriebsfaktor f _s	Typ	Nennstrom [A]	Gewicht ~ [kg]	Maße Seite	Preis No.	
0,55 0,75	21	239	68,03	7041	1,2	MR203-80/4a	1,60	31	105	MR117	
	24	209	59,43	6829	1,3	NR203-80/4a		33		NR117	
	25	197	55,74	6727	1,4						
	30	167	47,39	6468	1,7						
	32	155	43,94	6346	1,8						
	34	145	41,16	6242	1,9						
	39	127	36,02	6028	2,2						
	49	100	28,35	6501	2,8						
	57	87	24,77	6186	3,1						
	60	82	23,23	6043	3,3						
	20	243	69,16	4048	0,8	MR173-80/4a	1,60	20	104	MR118	
	24	203	57,76	3963	1,0	NR173-80/4a		22		NR118	
	28	175	49,81	3879	1,1						
	31	162	45,90	3827	1,2						
	33	151	42,87	3782	1,3						
	39	128	36,24	3664	1,6						
	46	107	30,26	3530	1,9						
	54	92	26,10	3416	2,2						
		67	75	20,92	3576	2,7	MR172-80/4a	1,60	19	104	MR119
		77	66	18,28	3428	3,0	NR172-80/4a		21		NR119
	28	178	50,51	2435	0,8	MR103-80/4a	1,60	20	103	MR120	
	31	157	44,60	2420	0,9	NR103-80/4a		21		NR120	
	34	147	41,66	2408	1,0						
	40	124	35,21	2368	1,1						
	43	114	32,25	2342	1,2						
	48	104	29,40	2312	1,3						
	56	88	24,86	2189	1,5						
	64	78	21,96	2147	1,5						
	68	72	20,51	2122	1,7						
	81	61	17,33	2056	1,8						
	88	57	15,95	2061	2,0	MR102-80/4a	1,60	19	103	MR121	
	99	51	14,08	2004	2,2	NR102-80/4a		20		NR121	
	106	47	13,15	1972	2,2						
	126	40	11,12	1894	2,5						
	137	37	10,18	1852	2,7						
	151	33	9,29	1809	2,8						
	175	29	8,01	1740	3,1						
	202	25	6,93	1657	3,6						
		44	112	32,02	681	0,7	MR003-80/4a	1,60	16	102	MR122
		49	100	28,38	853	0,8	NR003-80/4a		17		NR122
58		85	24,13	1085	1,0						
66		75	21,26	1169	1,1						
68		73	20,66	1257	1,1						
73		68	19,17	1324	1,2						
77		64	18,20	1315	1,3						
83		60	16,89	1372	1,4						
95		52	14,67	1392	1,6						
103		48	13,61	1433	1,7						
	126	40	11,14	1789	1,6	MR002-80/4a	1,60	14	102	MR123	
	142	35	9,87	1774	2,2	NR002-80/4a		15		NR123	
	161	31	8,70	1741	2,4						
	166	30	8,45	1762	2,4						
	179	28	7,84	1753	2,6						
	188	27	7,45	1724	2,7						



Motorlu Güç Devir Sayfaları

Geared Motors Performance Tables

Leistung und Drehzahlübersicht von Getriebemotoren

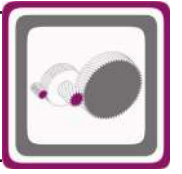

Güç	Çıkış Devri	Çıkış Momenti	Çevrim Oranı	Güv. Rad. Yük Çıkış	Servis Faktörü	Tipi	Anma Akımı	Ağırlık	Ölçü Sayfası	Fiyat Kodu	
Power	Output Speeds	Output Torque	Ratio	Per.O. Loads (Output)	Service Factors	Type	Rated Current	Weight	Dim. Page	Price Ref.	
Leistung P _g [kW] P _g [HP]	Abtriebswelle Drehzahlen n ₂ [r.p.m]	Abtriebswelle Drehmomente M ₂ [Nm]	Übersetzung i	Zul.Querkräfte (Abtrieb) F _{qam} [N]	Betriebsfaktor f _s	Typ	Nennstrom [A]	Gewicht ~ [kg]	Maße Seite	Preis No.	
0,55 0,75	203	25	6,91	1712	2,8	MR002-80/4a	1,60	14	102	MR123	
	233	22	6,00	1658	3,1	NR002-80/4a		15		NR123	
	251	20	5,57	1643	3,2						
	307	16	4,56	1535	3,5						
	359	14	3,90	1502	3,9						
	387	13	3,62	1485	4,0						
	405	12	6,91	1488	4,0	MR002-71/2b	1,27	14	102	MR124	
	467	11	6,00	1416	4,0	NR002-71/2b		15		NR124	
	503	10	5,57	1378	4,0						
	615	8	4,56	1288	4,0						
	718	7	3,90	1218	4,0						
	774	6	3,62	1185	4,0						
	0,75 1,0	0,26	23877	5357,43	39308	0,8	MR976-80/4b	2,00	1090	131	MR367
		0,31	19987	4474,67	81469	0,9	NR976-80/4b		1140		NR367
0,33		18896	4227,50	89168	1,0						
0,39		16089	3594,81	105912	1,1						
0,49		12737	2836,64	121560	1,4						
0,69		9288	2027,97	134374	1,9	MR975-80/4b	2,00	1088	131	MR368	
0,77		8345	1820,78	137427	2,2	NR975-80/4b		1138		NR368	
0,90		7109	1552,10	141175	2,5						
1,0		6272	1368,27	143560	2,9						
1,2		5568	1213,85	145470	3,2						
0,41		15291	3441,02	56525	0,9	MR876-80/4b	2,00	605	128	MR125	
0,48		12887	2894,28	73120	1,0	NR876-80/4b		610		NR125	
0,57		10977	2460,65	83131	1,2						
0,66		9422	2108,33	90089	1,4						
0,73		8774	1924,32	92488	1,5	MR875-80/4b	2,00	602	128	MR126	
0,82		7766	1700,56	96088	1,7	NR875-80/4b		607		NR126	
0,92		6950	1521,55	99023	1,9						
1,0		6113	1336,15	101682	2,1						
1,2		5542	1210,51	103390	2,3						
1,3		4795	1049,18	105498	2,7						
1,5		4191	915,85	107102	3,1						
1,7		3700	807,91	108336	3,5						
0,78		8152	1791,91	48294	1,0	MR775-80/4b	2,00	257	125	MR433	
0,88		7237	1589,68	51743	1,1	NR775-80/4b		315		NR433	
0,99		6456	1417,41	54336	1,2						
1,1		5715	1252,60	56638	1,4						
1,2		5115	1120,74	58321	1,6						
1,4		4500	984,18	59919	1,8						
1,5		4341	594,92	60314	1,8	MR774-90S/6	2,10	237	124	MR434	
1,7		3885	532,29	61398	2,1	NR774-90S/6		295		NR434	
1,9		3417	467,43	62443	2,3						
2,2		3060	418,17	63197	2,6						
2,4		2790	594,92	63743	2,9	MR774-80/4b	2,00	227	124	MR435	
2,6		2497	532,29	64311	3,2	NR774-80/4b		280		NR435	
3,0		2197	467,43	64965	3,6						
3,3		1967	418,17	65392	4,0						



Motorlu Güç Devir Sayfaları

Geared Motors Performance Tables

Leistung und Drehzahlübersicht von Getriebemotoren

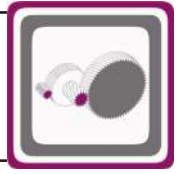

Güç	Çıkış Devri	Çıkış Momenti	Çevrim Oranı	Güv. Rad. Yük Çıkış	Servis Faktörü	Tipi	Anma Akımı	Ağırlık	Ölçü Sayfası	Fiyat Kodu	
Power	Output Speeds	Output Torque	Ratio	Per.O. Loads (Output)	Service Factors	Type	Rated Current	Weight	Dim. Page	Price Ref.	
Leistung P _g [kW] P _g [HP]	Abtriebswelle Drehzahlen n ₂ [r.p.m]	Abtriebswelle Drehmomente M ₂ [Nm]	Übersetzung i	Zul.Querkräfte (Abtrieb) F _{qam} [N]	Betriebsfaktor f _s	Typ	Nennstrom [A]	Gewicht ~ [kg]	Maße Seite	Preis No.	
0,75 1,0	1,4	4544	995,91	24906	0,9	MR675-80/4b	2,00	238	122	MR436	
	1,6	3998	874,56	28088	1,1	NR675-80/4b		249		NR436	
	1,8	3650	500,39	29829	1,2	MR674-90S/6	2,10	225	121	MR437	
	2,0	3231	442,20	31780	1,3	NR674-90S/6		235		NR437	
	2,4	2749	376,69	33755	1,6						
	2,8	2346	500,39	35205	1,8	MR674-80/4b	2,00	228	121	MR507	
	3,2	2077	442,20	36070	2,1	NR674-80/4b		239		NR507	
	3,7	1767	376,69	37069	2,4						
	4,3	1521	323,82	37783	2,8						
	5,0	1322	281,02	38332	3,3						
	5,7	1157	245,67	38767	3,7						
	6,5	1018	215,97	39119	4,0						
	2,2	2937	402,12	20175	1,0	MR574-90S/6	2,10	141	118	MR438	
							NR574-90S/6		137		NR438
	2,4	2689	574,90	21627	1,1	MR574-80/4b	2,00	135	118	MR439	
2,9	2276	485,89	23740	1,3	NR574-80/4b		132		NR439		
3,5	1888	402,12	25403	1,6							
4,1	1616	343,91	26434	1,9							
4,6	1420	301,59	27120	2,1							
4,8	1369	291,25	27289	2,2							
5,4	1218	258,87	27779	2,5							
6,3	1043	221,40	28324	2,9							
7,2	916	194,15	28687	3,3							
8,2	811	171,64	28986	3,7							
9,7	684	144,37	29323	4,0							
3,3	1962	418,16	6733	0,8	MR474-80/4b	2,00	135	115	MR134		
4,0	1627	346,07	14344	1,0	NR474-80/4b		139		NR134		
4,1	1628	219,00	14337	1,0	MR473-90S/6	2,10	94	114	MR135		
4,6	1442	194,05	16984	1,1	NR473-90S/6		97		NR135		
5,7	1176	157,90	19975	1,3							
6,4	1050	219,00	21139	1,5	MR473-80/4b	2,00	92	114	MR136		
7,2	930	194,05	22135	1,7	NR473-80/4b		95		NR136		
8,9	759	157,90	23453	2,0							
10	671	139,54	23247	2,3							
11	600	124,85	22545	2,6							
13	528	109,64	21737	2,9							
15	442	91,58	20645	3,5							
6,5	1030	138,72	7343	0,8	MR373-90S/6	2,10	55	111	MR137		
8,1	830	111,67	11533	1,0	NR373-90S/6		57		NR137		
8,9	755	157,76	12435	1,1	MR373-80/4b	2,00	51	111	MR138		
10	665	138,72	12134	1,2	NR373-80/4b		53		NR138		
13	536	111,67	11596	1,5							
14	470	97,92	11259	1,7							
16	416	86,57	10938	2,0							
19	350	72,81	10483	2,3							
23	298	61,91	10057	2,7							
26	256	53,04	9654	3,2							
29	232	48,00	9397	3,5							



Motorlu Güç Devir Sayfaları

Geared Motors Performance Tables

Leistung und Drehzahlübersicht von Getriebemotoren

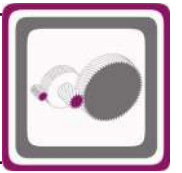

Güç	Çıkış Devri	Çıkış Momenti	Çevrim Oranı	Güv. Rad. Yük Çıkış	Servis Faktörü	Tipi	Anma Akımı	Ağırlık	Ölçü Sayfası	Fiyat Kodu
Power	Output Speeds	Output Torque	Ratio	Per.O. Loads (Output)	Service Factors	Type	Rated Current	Weight	Dim. Page	Price Ref.
Leistung P _g [kW] P _g [HP]	Abtriebswelle Drehzahlen n ₂ [r.p.m]	Abtriebswelle Drehmomente M ₂ [Nm]	Übersetzung i	Zul.Querkräfte (Abtrieb) F _{qam} [N]	Betriebsfaktor f _s	Typ	Nennstrom [A]	Gewicht ~ [kg]	Maße Seite	Preis No.
0,75 1,0	9,2	726	97,62	6265	0,8	MR283-90S/6 NR283-90S/6	2,10	42 44	108	MR139 NR139
	10	661	137,91	7990	0,9	MR283-80/4b NR283-80/4b	2,00	41 45	108	MR140 NR140
	12	548	114,14	9297	1,1					
	14	469	97,62	9035	1,3					
	16	411	85,60	8802	1,5					
	18	364	75,68	8575	1,6					
	22	307	63,65	8247	2,0					
	26	261	54,12	7934	2,3					
	30	224	46,37	7635	2,5					
	33	203	41,96	7442	2,7					
	12	581	121,03	5.409	0,8	MR273-80/4b NR273-80/4b	2,00	32 34	106	MR141 NR141
	13	545	113,52	5.715	0,8					
	15	463	96,52	6.349	1,0					
	17	403	83,83	6.758	1,1					
	19	353	73,35	7.043	1,3					
	23	292	60,66	7.306	1,5					
	28	244	50,59	7.429	1,8					
	33	205	42,41	7.128	2,2					
	38	177	36,55	6.746	2,5					
	46	148	30,48	6.312	3,1					
	21	327	68,03	6609	0,9	MR203-80/4b NR203-80/4b	2,00	30 32	105	MR142 NR142
	24	286	59,43	6451	1,0					
	25	268	55,74	6373	1,0					
	30	228	47,39	6167	1,2					
	32	212	43,94	6067	1,3					
	34	199	41,16	5980	1,4					
	39	174	36,02	5800	1,6					
	49	136	28,35	6628	2,1					
	57	119	24,77	6297	2,3					
	60	112	23,23	6147	2,4					
	61	112	23,01	6034	2,5	MR202-80/4b NR202-80/4b	2,00	30 31	105	MR143 NR143
	70	98	20,10	5744	2,6					
	74	92	18,85	5612	2,8					
	87	78	16,03	5293	3,1					
	28	240	49,81	3506	0,8	MR173-80/4b NR173-80/4b	2,00	20 21	104	MR144 NR144
	31	221	45,90	3484	0,9					
	33	206	42,87	3462	1,0					
	39	174	36,24	3394	1,1					
	46	146	30,26	3304	1,4					
	54	126	26,10	3221	1,6					
	67	102	20,92	3529	2,0	MR172-80/4b NR172-80/4b	2,00	20 22	104	MR145 NR145
	77	90	18,28	3388	2,2					
	82	84	17,14	3323	2,4					
	96	71	14,57	3162	2,7					
	111	62	12,66	3027	3,1					
	126	54	11,08	2903	3,3					
	40	170	35,21	2088	0,8	MR103-80/4b NR103-80/4b	2,00	19 22	103	MR146 NR146
	43	156	32,25	2086	0,9					
	48	142	29,40	2078	1,0					
	56	120	24,86	1969	1,1					
	64	106	21,96	1952	1,1					



Motorlu Güç Devir Sayfaları

Geared Motors Performance Tables

Leistung und Drehzahlübersicht von Getriebemotoren



Güç	Çıkış Devri	Çıkış Momenti	Çevrim Oranı	Güv. Rad. Yük Çıkış	Servis Faktörü	Tipi	Anma Akımı	Ağırlık	Ölçü Sayfası	Fiyat Kodu	
Power	Output Speeds	Output Torque	Ratio	Per.O. Loads (Output)	Service Factors	Type	Rated Current	Weight	Dim. Page	Price Ref.	
Leistung P _g [kW] P _g [HP]	Abtriebswelle Drehzahlen n ₂ [r.p.m]	Abtriebswelle Drehmomente M ₂ [Nm]	Übersetzung i	Zul.Querkräfte (Abtrieb) F _{qam} [N]	Betriebsfaktor f _s	Typ	Nennstrom [A]	Gewicht ~ [kg]	Maße Seite	Preis No.	
0,75 1,0	68	99	20,51	1940	1,2	MR103-80/4b	2,00	19	103	MR146	
	81	84	17,33	1903	1,3	NR103-80/4b		22		NR146	
	88	78	15,95	1934	1,5	MR102-80/4b	2,00	19	103	MR147	
	99	69	14,08	1892	1,6	NR102-80/4b		20		NR147	
	106	64	13,15	1868	1,6						
	126	55	11,12	1805	1,8						
	137	50	10,18	1772	2,0						
	151	46	9,29	1735	2,1						
	175	39	8,01	1677	2,3						
	202	34	6,93	1596	2,6						
	216	32	6,48	1570	2,7						
	256	27	5,47	1506	3,0						
	279	25	5,01	1472	3,2						
	306	22	4,57	1437	3,3						
		58	116	24,13	203	0,7	MR003-80/4b	2,00	16	102	MR148
		66	102	21,26	370	0,8	NR003-80/4b		17		NR148
68		100	20,66	502	0,8						
73		92	19,17	624	0,9						
77		88	18,20	631	0,9						
83		81	16,89	738	1,0						
95		71	14,67	817	1,2						
103		66	13,61	899	1,2						
		126	54	11,14	1453	1,2	MR002-80/4b	2,00	16	102	MR149
	142	48	9,87	1471	1,6	NR002-80/4b		17		NR149	
	161	43	8,70	1466	1,7						
	166	41	8,45	1503	1,8						
	179	38	7,84	1512	1,9						
	188	36	7,45	1488	1,9						
	203	34	6,91	1493	2,0						
	233	29	6,00	1458	2,2						
	251	27	5,57	1458	2,3						
	307	22	4,56	1361	2,6						
	359	19	3,90	1353	2,9						
	387	18	3,62	1346	3,0						
		405	17	6,91	1426	3,2	MR002-80/2a	1,80	17	102	MR150
467		15	6,00	1377	3,5	NR002-80/2a		18		NR150	
503		14	5,57	1361	3,7						
615		11	4,56	1272	4,0						
718		10	3,90	1236	4,0						
774		9	3,62	1202	4,0						
1,1 1,5	0,39	23598	3594,81	43789	0,8	MR976-90S/4	2,60	1092	131	MR369	
	0,49	18682	2836,64	90609	1,0	NR976-90S/4		1142		NR369	
	0,69	13622	2027,97	117785	1,3	MR975-90S/4	2,60	1090	131	MR370	
	0,77	12239	1820,78	123364	1,5	NR975-90S/4		1140		NR370	
	0,90	10426	1552,10	130549	1,7						
	1,0	9199	1368,27	134670	2,0						
	1,2	8167	1213,85	137984	2,2						
	1,3	7287	1082,31	140653	2,5						
	1,5	6173	914,74	143832	2,9						
	1,7	5684	842,80	145160	3,2						
	0,73	12868	1924,32	73232	1,0	MR875-90S/4	2,60	595	128	MR151	
	0,82	11390	1700,56	81134	1,1	NR875-90S/4		600		NR151	



Motorlu Güç Devir Sayfaları

Geared Motors Performance Tables

Leistung und Drehzahlübersicht von Getriebemotoren

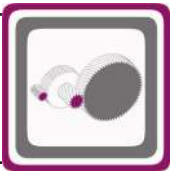

Güç	Çıkış Devri	Çıkış Momenti	Çevrim Oranı	Güv. Rad. Yük Çıkış	Servis Faktörü	Tipi	Anma Akımı	Ağırlık	Ölçü Sayfası	Fiyat Kodu
Power	Output Speeds	Output Torque	Ratio	Per.O. Loads (Output)	Service Factors	Type	Rated Current	Weight	Dim. Page	Price Ref.
Leistung P _g [kW] P _g [HP]	Abtriebswelle Drehzahlen n ₂ [r.p.m]	Abtriebswelle Drehmomente M ₂ [Nm]	Übersetzung i	Zul.Querkräfte (Abtrieb) F _{qam} [N]	Betriebsfaktor f _s	Typ	Nennstrom [A]	Gewicht ~ [kg]	Maße Seite	Preis No.
1,1 1,5	0,92	10193	1521,55	86705	1,3	MR875-90S/4	2,60	595	128	MR151
	1,0	8966	1336,15	91754	1,4	NR875-90S/4		600		NR151
	1,2	8129	1210,51	94838	1,6					
	1,3	7033	1049,18	98746	1,8					
	1,5	6146	915,85	101581	2,1					
	1,7	5427	807,91	103725	2,4					
	1,9	4832	718,74	105398	2,7					
	2,2	4332	643,84	106736	3,0					
	2,6	3627	537,75	108515	3,6					
	1,1	8382	1252,60	47349	1,0	MR775-90S/4	2,60	333	125	MR440
	1,2	7502	1120,74	50776	1,1	NR775-90S/4		403		NR440
	1,4	6601	984,18	53879	1,2					
	1,5	6366	594,92	54616	1,3	MR774-90L/6	3,00	306	124	MR441
	1,7	5698	532,29	56689	1,4	NR774-90L/6		372		NR441
	1,9	5012	467,43	58598	1,6					
	2,2	4488	418,17	59949	1,8					
	2,4	4093	594,92	60912	2,0	MR774-90S/4	2,60	300	124	MR442
	2,6	3663	532,29	61903	2,2	NR774-90S/4		366		NR442
	3,0	3222	467,43	62860	2,5					
3,3	2885	418,17	63553	2,8						
3,9	2492	361,62	64321	3,2						
4,5	2161	313,11	65032	3,7						
5,1	1893	273,85	65528	4,0						
2,0	4738	442,20	23566	0,9	MR674-90L/6	3,00	230	121	MR443	
2,4	4031	376,69	27909	1,1	NR674-90L/6		240		NR443	
2,8	3441	500,39	30857	1,2	MR674-90S/4	2,60	225	121	MR444	
3,2	3046	442,20	32534	1,4	NR674-90S/4		235		NR444	
3,7	2591	376,69	34344	1,7						
4,3	2231	323,82	35584	1,9						
5,0	1939	281,02	36545	2,2						
5,7	1697	245,67	37277	2,5						
6,5	1493	215,97	37861	2,9						
3,5	2769	402,12	21171	1,1	MR574-90S/4	2,60	146	118	MR445	
4,1	2370	343,91	23264	1,3	NR574-90S/4		142		NR445	
4,6	2082	301,59	24576	1,4						
4,8	2008	291,25	24890	1,5						
5,4	1787	258,87	25783	1,7						
6,3	1529	221,40	26748	2,0						
7,2	1344	194,15	27372	2,2						
8,2	1190	171,64	27871	2,5						
9,7	1003	144,37	28436	3,0						
5,7	1727	157,90	12637	0,9	MR473-90L/6	3,00	94	114	MR159	
					NR473-90L/6		96		NR159	
6,4	1541	219,00	15655	1,0	MR473-90S/4	2,60	92	114	MR160	
7,2	1365	194,05	17922	1,1	NR473-90S/4		94		NR160	
8,9	1113	157,90	20563	1,4						
10	985	139,54	21700	1,6						
11	881	124,85	21675	1,8						



Motorlu Güç Devir Sayfaları

Geared Motors Performance Tables

Leistung und Drehzahlübersicht von Getriebemotoren

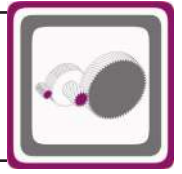

Güç	Çıkış Devri	Çıkış Momenti	Çevrim Oranı	Güv. Rad. Yük Çıkış	Servis Faktörü	Tipi	Anma Akımı	Ağırlık	Ölçü Sayfası	Fiyat Kodu
Power	Output Speeds	Output Torque	Ratio	Per.O. Loads (Output)	Service Factors	Type	Rated Current	Weight	Dim. Page	Price Ref.
Leistung P _g [kW] P _g [HP]	Abtriebswelle Drehzahlen n ₂ [r.p.m]	Abtriebswelle Drehmomente M ₂ [Nm]	Übersetzung i	Zul.Querkräfte (Abtrieb) F _{qam} [N]	Betriebsfaktor f _s	Typ	Nennstrom [A]	Gewicht ~ [kg]	Maße Seite	Preis No.
1,1 1,5	13	775	109,64	20973	2,0	MR473-90S/4	2,60	92	114	MR160
	15	648	91,58	20007	2,4	NR473-90S/4		94		NR160
	16	613	86,52	19705	2,5					
	10	976	138,72	8775	0,8	MR373-90S/4	2,60	53	111	MR161
	13	786	111,67	10669	1,0	NR373-90S/4		56		NR161
	14	690	97,92	10446	1,2					
	16	611	86,57	10219	1,3					
	19	514	72,81	9879	1,6					
	23	438	61,91	9543	1,9					
	26	376	53,04	9214	2,2					
29	340	48,00	8999	2,4						
39	260	23,33	9769	3,1	MR372-90L/6	3,00	56	111	MR162	
	44	230	20,62	9343	3,6	NR372-90L/6		60		NR162
14	688	97,62	7332	0,9	MR283-90S/4	2,60	45	108	MR163	
	16	604	85,60	8018	1,0	NR283-90S/4		49		NR163
	18	534	75,68	7882	1,1					
	22	450	63,65	7664	1,3					
	26	383	54,12	7439	1,6					
	30	329	46,37	7210	1,7					
	33	298	41,96	7057	1,8					
	36	281	25,23	8599	2,1	MR282-90L/6	3,00	44	108	MR164
42	241	21,66	8127	2,4	NR282-90L/6		48		NR164	
46	218	30,37	7824	2,6	MR282-90S/4	2,60	45	108	MR165	
	55	181	25,23	7312	2,9	NR282-90S/4		48		NR165
	65	156	21,66	6919	3,2					
17	591	83,83	3.440	0,8	MR273-90S/4	2,60	35	106	MR166	
	19	518	73,35	4.140	0,9	NR273-90S/4		37		NR166
	23	429	60,66	4.905	1,0					
	28	358	50,59	5.426	1,3					
	33	301	42,41	5.775	1,5					
	38	259	36,55	5.969	1,7					
	46	216	30,48	6.107	2,1					
	54	186	25,89	6.058	2,4	MR272-90S/4	2,60	36	106	MR167
65		154	21,43	5.648	2,9	NR272-90S/4		38		NR167
76		132	18,33	5.333	3,4					
30	335	47,39	5640	0,8	MR203-90S/4	2,60	34	105	MR168	
	32	311	43,94	5579	0,9	NR203-90S/4		37		NR168
	34	291	41,16	5523	1,0					
	39	255	36,02	5400	1,1					
	49	200	28,35	5528	1,4					
	57	175	24,77	5715	1,6					
	60	164	23,23	5781	1,6					
	61	165	23,01	6170	1,7	MR202-90S/4	2,60	36	105	MR169
70		144	20,10	5863	1,8	NR202-90S/4		38		NR169
74		135	18,85	5724	1,9					
87		115	16,03	5389	2,1					
94		107	14,86	5240	2,2					
101		100	13,92	5116	2,3					



Motorlu Güç Devir Sayfaları

Geared Motors Performance Tables

Leistung und Drehzahlübersicht von Getriebemotoren

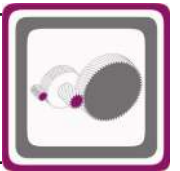

Güç	Çıkış Devri	Çıkış Momenti	Çevrim Oranı	Güv. Rad. Yük Çıkış	Servis Faktörü	Tipi	Anma Akımı	Ağırlık	Ölçü Sayfası	Fiyat Kodu
Power	Output Speeds	Output Torque	Ratio	Per.O. Loads (Output)	Service Factors	Type	Rated Current	Weight	Dim. Page	Price Ref.
Leistung P _g [kW] P _g [HP]	Abtriebswelle Drehzahlen n ₂ [r.p.m]	Abtriebswelle Drehmomente M ₂ [Nm]	Übersetzung i	Zul.Querkräfte (Abtrieb) F _{qam} [N]	Betriebsfaktor f _s	Typ	Nennstrom [A]	Gewicht ~ [kg]	Maße Seite	Preis No.
1,1 1,5	115	88	12,18	4872	2,6	MR202-90S/4	2,60	36	105	MR169
	130	78	10,81	4664	2,8	NR202-90S/4		38		NR169
	139	73	10,07	4547	2,9					
	167	61	8,40	4260	3,3					
	39	256	36,24	2920	0,8	MR173-90S/4	2,60	25	104	MR170
	46	214	30,26	2908	0,9	NR173-90S/4		27		NR170
	54	185	26,10	2879	1,1					
	67	150	20,92	3430	1,3	MR172-90S/4	2,60	24	104	MR171
	77	131	18,28	3306	1,5	NR172-90S/4		25		NR171
	82	123	17,14	3248	1,6					
	96	105	14,57	3101	1,9					
	111	91	12,66	2976	2,1					
126	80	11,08	2861	2,3						
147	69	9,53	2703	2,5						
157	65	8,94	2652	2,6						
184	55	7,60	2526	2,9						
212	48	6,60	2420	3,0						
242	42	5,78	2322	3,2						
56	176	24,86	1584	0,7	MR103-90S/4	2,60	24	103	MR172	
64	155	21,96	1612	0,8	NR103-90S/4		26		NR172	
68	145	20,51	1622	0,8						
81	123	17,33	1634	0,9						
88	115	15,95	1712	1,0	MR102-90S/4	2,60	25	103	MR173	
99	101	14,08	1696	1,1	NR102-90S/4		26		NR173	
106	95	13,15	1685	1,1						
126	80	11,12	1651	1,2						
137	73	10,18	1630	1,4						
151	67	9,29	1606	1,4						
175	58	8,01	1565	1,6						
202	50	6,93	1488	1,8						
216	47	6,48	1469	1,8						
256	39	5,47	1421	2,0						
279	36	5,01	1395	2,2						
306	33	4,57	1366	2,3						
355	28	3,94	1321	2,5						
404	25	6,93	1280	2,8	MR102-80/2b	2,40	23	103	MR174	
432	23	6,48	1259	3,0	NR102-80/2b		24		NR174	
512	20	5,47	1206	3,3						
95	104	14,67	-	-	0,8	MR003-90S/4	2,60	19	102	MR175
103	96	13,61	-	-	0,8	NR003-90S/4		20		NR175
126	80	11,14	864	0,8	MR002-90S/4	2,60	19	102	MR176	
142	71	9,87	941	1,1	NR002-90S/4		20		NR176	
161	62	8,70	984	1,2						
166	61	8,45	1050	1,2						
179	56	7,84	1091	1,3						
188	54	7,45	1076	1,3						
203	50	6,91	1111	1,4						
233	43	6,00	1109	1,5						
251	40	5,57	1133	1,6						
307	33	4,56	1056	1,8						
359	28	3,90	1092	2,0						
387	26	3,62	1104	2,0						



Motorlu Güç Devir Sayfaları

Geared Motors Performance Tables

Leistung und Drehzahlübersicht von Getriebemotoren

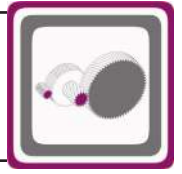

Güç	Çıkış Devri	Çıkış Momenti	Çevrim Oranı	Güv. Rad. Yük Çıkış	Servis Faktörü	Tipi	Anma Akımı	Ağırlık	Ölçü Sayfası	Fiyat Kodu			
Power	Output Speeds	Output Torque	Ratio	Per.O. Loads (Output)	Service Factors	Type	Rated Current	Weight	Dim. Page	Price Ref.			
Leistung P _g [kW] P _g [HP]	Abtriebswelle Drehzahlen n ₂ [r.p.m]	Abtriebswelle Drehmomente M ₂ [Nm]	Übersetzung i	Zul.Querkräfte (Abtrieb) F _{qam} [N]	Betriebsfaktor f _s	Typ	Nennstrom [A]	Gewicht ~ [kg]	Maße Seite	Preis No.			
1,1 1,5	405	25	6,91	1235	2,2	MR002-80/2b	2,40	16	102	MR177			
	467	22	6,00	1203	2,4	NR002-80/2b		18					
	503	20	5,57	1199	2,5								
	615	16	4,56	1120	2,8								
	718	14	3,90	1108	3,1								
	774	13	3,62	1100	3,2								
1,5 2,0	0,69	18576	2027,97	91307	1,0	MR975-90L/4	3,50	1026	131	MR371			
	0,77	16689	1820,78	102672	1,1	NR975-90L/4		1076					
	0,90	14217	1552,10	115114	1,3								
	1,0	12544	1368,27	122357	1,4								
	1,2	11136	1213,85	127825	1,6								
	1,3	9936	1082,31	132362	1,8								
	1,5	8418	914,74	137195	2,1								
	1,7	7751	842,80	139260	2,3								
	1,9	6913	750,24	141742	2,6								
	2,1	6117	662,54	143988	2,9								
	2,4	5446	588,87	145792	3,3								
	0,82	15532	1700,56	54554	0,8	MR875-90L/4		3,50			590	128	MR178
	0,92	13899	1521,55	66871	0,9	NR875-90L/4					595		
	1,0	12226	1336,15	76816	1,1								
	1,2	11085	1210,51	82618	1,2								
	1,3	9591	1049,18	89262	1,4								
	1,5	8381	915,85	93938	1,6								
	1,7	7400	807,91	97508	1,8								
	2,0	6521	446,42	100411	2,0	MR874-100L/6					3,50		
	2,3	5718	390,74	102874	2,3	NR874-100L/6		588					
	2,6	5067	345,67	104749	2,6								
	3,1	4292	292,15	106840	3,0								
	3,8	3523	239,61	108766	3,7								
	1,5	8681	594,92	46075	0,9	MR774-100L/6		3,50			319	124	MR446
1,7	7769	532,29	49868	1,0	NR774-100L/6	390							
1,9	6834	467,43	53117	1,2									
2,2	6121	418,17	55359	1,3									
2,4	5581	594,92	57026	1,4	MR774-90L/4	3,50	313	124	MR447				
2,6	4995	532,29	58645	1,6	NR774-90L/4		380						
3,0	4394	467,43	60184	1,8									
3,3	3935	418,17	61282	2,0									
3,9	3398	361,62	62484	2,4									
4,5	2947	313,11	63429	2,7									
5,1	2581	273,85	64151	3,1									
5,8	2278	241,42	64811	3,5									
6,5	2023	214,17	65289	4,0									
2,8	4692	500,39	23872	0,9	MR674-90L/4		3,50			232	121	MR448	
3,2	4154	442,20	27234	1,0	NR674-90L/4					243			
3,7	3534	376,69	30429	1,2									
4,3	3042	323,82	32549	1,4									
5,0	2644	281,02	34150	1,6									
5,7	2314	245,67	35313	1,9									
6,5	2036	215,97	36194	2,1									



Motorlu Güç Devir Sayfaları

Geared Motors Performance Tables

Leistung und Drehzahlübersicht von Getriebemotoren

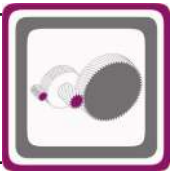

Güç	Çıkış Devri	Çıkış Momenti	Çevrim Oranı	Güv. Rad. Yük Çıkış	Servis Faktörü	Tipi	Anma Akımı	Ağırlık	Ölçü Sayfası	Fiyat Kodu	
Power	Output Speeds	Output Torque	Ratio	Per.O. Loads (Output)	Service Factors	Type	Rated Current	Weight	Dim. Page	Price Ref.	
Leistung P _g [kW] P _g [HP]	Abtriebswelle Drehzahlen n ₂ [r.p.m]	Abtriebswelle Drehmomente M ₂ [Nm]	Übersetzung i	Zul.Querkräfte (Abtrieb) F _{qam} [N]	Betriebsfaktor f _s	Typ	Nennstrom [A]	Gewicht ~ [kg]	Maße Seite	Preis No.	
1,5 2,0	4,1	3232	343,91	18265	0,9	MR574-90L/4	3,50	148	118	MR449	
	4,6	2839	301,59	20766	1,1	NR574-90L/4		132		NR449	
	5,4	2493	167,32	22643	1,2	MR573-100L/6	3,50	136	117	MR450	
	5,9	2288	153,61	23689	1,3	NR573-100L/6		132		NR450	
	6,7	2005	134,45	24912	1,5						
	7,6	1776	118,95	25824	1,7						
	9,0	1503	100,53	26829	2,0						
	11	1233	82,45	27756	2,4						
	12	1090	72,81	28181	2,8						
	14	970	64,72	28500	3,1						
	16	822	54,74	28954	3,7						
	18	733	48,74	29184	4,0						
		7,2	1864	194,05	9664	0,8	MR473-90L/4	3,50	95	114	MR188
		8,9	1520	157,90	15941	1,0	NR473-90L/4		97		NR188
10		1344	139,54	18160	1,2						
11		1203	124,85	19686	1,3						
13		1058	109,64	20100	1,5						
15		885	91,58	19278	1,8						
16		836	86,52	19016	1,9						
	18	758	157,90	18593	2,0	MR473-90S/2	3,30	94	114	MR189	
	20	671	139,54	18022	2,3	NR473-90S/2		96		NR189	
	22	600	124,85	17509	2,6						
	26	528	109,64	16915	2,9						
	14	942	97,92	9517	0,9	MR373-90L/4	3,50	56	111	MR190	
	16	833	86,57	9398	1,0	NR373-90L/4		59		NR190	
	19	702	72,81	9188	1,2						
	23	598	61,91	8956	1,4						
	26	513	53,04	8711	1,6						
	29	464	48,00	8543	1,8						
	39	355	23,33	9919	2,3	MR372-100L/6	3,50	58	111	MR191	
	44	314	20,62	9476	2,6	NR372-100L/6		60		NR191	
	49	281	18,45	9097	2,9						
	56	247	16,20	8676	3,3						
	60	229	23,33	8437	3,5	MR372-90L/4	3,50	55	111	MR192	
	68	203	20,62	8069	3,8	NR372-90L/4		57		NR192	
	76	181	18,45	7753	4,0						
	18	729	75,68	6130	0,8	MR283-90L/4	3,50	47	108	MR193	
	22	614	63,65	6998	1,0	NR283-90L/4		49		NR193	
	26	523	54,12	6872	1,1						
	30	449	46,37	6725	1,3						
	33	406	41,96	6618	1,4						
	36	384	25,23	8499	1,6	MR282-100L/6	3,50	51	108	MR194	
	42	329	21,66	8280	1,8	NR282-100L/6		53		NR194	
	46	297	30,37	7962	1,9	MR282-90L/4	3,50	46	108	MR195	
	55	247	25,23	7428	2,1	NR282-90L/4		48		NR195	
	65	212	21,66	7020	2,4						
	73	187	19,06	6698	2,6						
	83	166	16,91	6412	2,8						



Motorlu Güç Devir Sayfaları

Geared Motors Performance Tables

Leistung und Drehzahlübersicht von Getriebemotoren

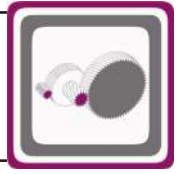

Güç	Çıkış Devri	Çıkış Momenti	Çevrim Oranı	Güv. Rad. Yük Çıkış	Servis Faktörü	Tipi	Anma Akımı	Ağırlık	Ölçü Sayfası	Fiyat Kodu
Power	Output Speeds	Output Torque	Ratio	Per.O. Loads (Output)	Service Factors	Type	Rated Current	Weight	Dim. Page	Price Ref.
Leistung P _g [kW] P _g [HP]	Abtriebswelle Drehzahlen n ₂ [r.p.m]	Abtriebswelle Drehmomente M ₂ [Nm]	Übersetzung i	Zul.Querkräfte (Abtrieb) F _{qam} [N]	Betriebsfaktor f _s	Typ	Nennstrom [A]	Gewicht ~ [kg]	Maße Seite	Preis No.
1,5 2,0	98	141	14,31	6035	3,1	MR282-90L/4 NR282-90L/4	3,50	46 48	108	MR195 NR195
	23 28 33 38 46	585 489 410 354 295	60,66 50,59 42,41 36,55 30,48	2.161 3.138 3.857 4.316 4.728	0,8 0,9 1,1 1,3 1,5	MR273-90L/4 NR273-90L/4	3,50	38 40	106	MR196 NR196
	54 65 76 87 99 117	254 211 180 158 140 118	25,89 21,43 18,33 16,07 14,21 11,95	4.983 5.167 5.246 5.165 4.934 4.630	1,8 2,1 2,5 2,7 2,9 3,3	MR272-90L/4 NR272-90L/4	3,50	37 39	106	MR197 NR197
	39 49 57 60	348 273 239 224	36,02 28,35 24,77 23,23	4942 3628 4055 4224	0,8 1,0 1,1 1,2	MR203-90L/4 NR203-90L/4	3,50	38 39	105	MR198 NR198
	61 70 74 87 94 101 115 130 139 167 199 241	225 197 185 157 146 137 120 106 99 83 69 57	23,01 20,10 18,85 16,03 14,86 13,92 12,18 10,81 10,07 8,40 7,04 5,80	5187 5358 5418 5496 5340 5210 4954 4738 4616 4317 4048 3820	1,2 1,3 1,4 1,6 1,6 1,7 1,9 2,0 2,1 2,4 2,7 3,1	MR202-90L/4 NR202-90L/4	3,50	36 38	105	MR199 NR199
	67 77 82 96 111 126 147 157 184 212 242 293 343 414	205 179 168 143 125 109 94 88 75 65 57 47 40 33	20,92 18,28 17,14 14,57 12,66 11,08 9,53 8,94 7,60 6,60 5,78 4,78 4,09 3,38	3291 3192 3143 3018 2908 2804 2642 2596 2481 2382 2290 2164 2049 1934	1,0 1,1 1,2 1,4 1,5 1,7 1,8 1,9 2,1 2,2 2,4 2,8 3,0 3,3	MR172-90L/4 NR172-90L/4	3,50	26 28	104	MR200 NR200
	424 485 586 685 829	32 28 24 20 17	6,60 5,78 4,78 4,09 3,38	1931 1852 1744 1653 1556	3,8 4,0 4,0 4,0 4,0	MR172-90S/2 NR172-90S/2	3,30	26 28	104	MR201 NR201
	99 106 126 137	138 129 109 100	14,08 13,15 11,12 10,18	1472 1476 1474 1468	0,8 0,8 0,9 1,0	MR102-90L/4 NR102-90L/4	3,50	25 26	103	MR202 NR202



Motorlu Güç Devir Sayfaları

Geared Motors Performance Tables

Leistung und Drehzahlübersicht von Getriebemotoren

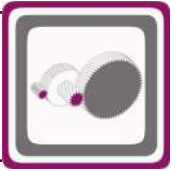

Güç	Çıkış Devri	Çıkış Momenti	Çevrim Oranı	Güv. Rad. Yük Çıkış	Servis Faktörü	Tipi	Anma Akımı	Ağırlık	Ölçü Sayfası	Fiyat Kodu						
Power	Output Speeds	Output Torque	Ratio	Per.O. Loads (Output)	Service Factors	Type	Rated Current	Weight	Dim. Page	Price Ref.						
Leistung P _g [kW] P _g [HP]	Abtriebswelle Drehzahlen n ₂ [r.p.m]	Abtriebswelle Drehmomente M ₂ [Nm]	Übersetzung i	Zul.Querkräfte (Abtrieb) F _{qam} [N]	Betriebsfaktor f _s	Typ	Nennstrom [A]	Gewicht ~ [kg]	Maße Seite	Preis No.						
1,5 2,0	151	91	9,29	1459	1,0	MR102-90L/4	3,50	25	103	MR202						
	175	79	8,01	1438	1,1	NR102-90L/4		26			NR202					
	202	68	6,93	1366	1,3											
	216	64	6,48	1355	1,3											
	256	54	5,47	1324	1,5											
	279	49	5,01	1306	1,6											
	306	45	4,57	1286	1,7											
	355	39	3,94	1251	1,8											
	404	34	6,93	1219	2,1	MR102-90S/2		3,30				24	103	MR203		
	432	32	6,48	1202	2,2	NR102-90S/2						26			NR203	
	512	27	5,47	1158	2,4											
	559	25	5,01	1134	2,4											
	613	22	4,57	1109	2,7											
	710	19	3,94	1070	2,8											
	142	97	9,87	336	0,8	MR002-90L/4	3,50	22	102	MR204						
	161	85	8,70	433	0,9	NR002-90L/4		23			NR204					
	166	83	8,45	531	0,9											
	179	77	7,84	610	0,9											
	188	73	7,45	604	1,0											
	203	68	6,91	673	1,0											
	233	59	6,00	709	1,1											
	251	55	5,57	763	1,2											
	307	45	4,56	708	1,3											
	359	38	3,90	794	1,4											
	387	36	3,62	828	1,5											
	405	34	6,91	1016	1,6	MR002-90S/2		3,30				21	102	MR205		
	467	29	6,00	1003	1,8	NR002-90S/2						23			NR205	
	503	27	5,57	1014	1,9											
615	22	4,56	945	2,1												
718	19	3,90	959	2,3												
774	18	3,62	962	2,4												
2,2 3,0	0,90	20852	1552,10	74382	0,9	MR975-100L/4a	5,10	1110	131	MR372						
	1,0	18397	1368,27	92469	1,0	NR975-100L/4a		1160			NR372					
	1,2	16333	1213,85	104614	1,1											
	1,3	14573	1082,31	113462	1,2											
	1,5	12347	914,74	122911	1,5											
	1,7	11369	842,80	126908	1,6											
	1,9	10140	750,24	131615	1,8											
	2,1	8971	662,54	135418	2,0											
	2,4	7988	588,87	138537	2,3											
	2,6	7407	546,94	140296	2,4											
	2,7	7059	510,11	141319	2,5	MR974-100L/4a		5,10				1125	130	MR373		
	3,1	6344	457,99	143358	2,8	NR974-100L/4a						1175			NR373	
	3,6	5407	390,41	145895	3,3											
	1,2	16258	1210,51	47959	0,8	MR875-100L/4a		5,10				615	128	MR206		
	1,3	14067	1049,18	65987	0,9	NR875-100L/4a	620		NR206							
	1,5	12292	915,85	76459	1,1											
	1,7	10854	807,91	83711	1,2											
	1,9	9664	718,74	88960	1,3											
	2,3	8386	390,74	93920	1,6	MR874-112M/6	5,10	605		127	MR207					
	2,6	7431	345,67	97403	1,7	NR874-112M/6		610	NR207							



Motorlu Güç Devir Sayfaları

Geared Motors Performance Tables

Leistung und Drehzahlübersicht von Getriebemotoren

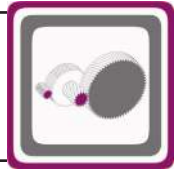

Güç	Çıkış Devri	Çıkış Momenti	Çevrim Oranı	Güv. Rad. Yük Çıkış	Servis Faktörü	Tipi	Anma Akımı	Ağırlık	Ölçü Sayfası	Fiyat Kodu
Power	Output Speeds	Output Torque	Ratio	Per.O. Loads (Output)	Service Factors	Type	Rated Current	Weight	Dim. Page	Price Ref.
Leistung P _g [kW] P _g [HP]	Abtriebswelle Drehzahlen n ₂ [r.p.m]	Abtriebswelle Drehmomente M ₂ [Nm]	Übersetzung i	Zul.Querkräfte (Abtrieb) F _{qam} [N]	Betriebsfaktor f _s	Typ	Nennstrom [A]	Gewicht ~ [kg]	Maße Seite	Preis No.
2,2 3,0	3,1	6148	446,42	101575	2,1	MR874-100L/4a	5,10	600	127	MR208
	3,6	5391	390,74	103828	2,4	NR874-100L/4a		605		NR208
	4,1	4777	345,67	105548	2,7					
	4,8	4046	292,15	107471	3,2					
	5,8	3322	239,61	109247	3,9					
	2,4	8185	594,92	48159	1,0	MR774-100L/4a	5,10	324	124	MR451
	2,6	7325	532,29	51343	1,1	NR774-100L/4a		397		NR451
	3,0	6444	467,43	54375	1,2					
	3,3	5771	418,17	56475	1,4					
	3,9	4984	361,62	58672	1,6					
	4,5	4322	313,11	60359	1,9					
	5,1	3786	273,85	61625	2,1					
	5,8	3341	241,42	62607	2,4					
	6,5	2968	214,17	63387	2,7					
	7,3	2649	190,96	64020	3,0					
	4,6	4300	196,61	26433	1,0	MR673-112M/6	5,10	195	120	MR452
	5,1	3829	174,89	29022	1,1	NR673-112M/6		196		NR452
	6,0	3269	149,11	31639	1,3					
	7,3	2721	124,07	33858	1,6					
	8,1	2427	110,55	34930	1,8					
	6,7	2945	134,45	20141	1,0	MR573-112M/6	5,10	143	117	MR453
	7,6	2608	118,95	22061	1,2	NR573-112M/6		149		NR453
	8,4	2361	167,32	23297	1,3	MR573-100L/4a	5,10	133	117	MR454
	9,1	2167	153,61	24211	1,4	NR573-100L/4a		139		NR454
	10	1899	134,45	25379	1,6					
	12	1682	118,95	26195	1,8					
	14	1424	100,53	24004	2,1					
	17	1169	82,45	27936	2,6					
	19	1033	72,81	28344	2,9					
	22	919	64,72	27884	3,3					
	26	779	54,74	26593	3,9					
	29	695	48,74	25718	4,0					
	10	1973	139,54	6265	0,8	MR473-100L/4a	5,10	101	114	MR218
	11	1765	124,85	11889	0,9	NR473-100L/4a		104		NR218
	13	1552	109,64	15509	1,0					
	15	1298	91,58	18002	1,2					
	16	1227	86,52	17811	1,3					
	17	1196	84,46	17728	1,3					
	19	1037	73,09	17218	1,5					
	22	905	63,70	16715	1,7					
	25	794	55,82	16219	2,0					
	29	698	49,05	15728	2,2					
	33	609	42,75	15204	2,5					
	37	534	37,45	14699	2,9					
	45	442	30,93	13976	3,5					
	19	1030	72,81	7353	0,8	MR373-100L/4a	5,10	60	111	MR219
	23	877	61,91	7928	0,9	NR373-100L/4a		61		NR219
	26	752	53,04	7830	1,1					
	29	681	48,00	7746	1,2					
	34	584	41,16	7591	1,4					
	40	501	35,25	7409	1,6					
	47	420	29,47	7175	1,8					
	55	360	25,27	6959	2,0					



Motorlu Güç Devir Sayfaları

Geared Motors Performance Tables

Leistung und Drehzahlübersicht von Getriebemotoren



Güç	Çıkış Devri	Çıkış Momenti	Çevrim Oranı	Güv. Rad. Yük Çıkış	Servis Faktörü	Tipi	Anma Akımı	Ağırlık	Ölçü Sayfası	Fiyat Kodu
Power	Output Speeds	Output Torque	Ratio	Per.O. Loads (Output)	Service Factors	Type	Rated Current	Weight	Dim. Page	Price Ref.
Leistung P _g [kW] P _g [HP]	Abtriebswelle Drehzahlen n ₂ [r.p.m]	Abtriebswelle Drehmomente M ₂ [Nm]	Übersetzung i	Zul.Querkräfte (Abtrieb) F _{qam} [N]	Betriebsfaktor f _s	Typ	Nennstrom [A]	Gewicht ~ [kg]	Maße Seite	Preis No.
2,2 3,0	60	336	23,33	8604	2,4	MR372-100L/4a	5,10	59	111	MR220
	68	298	20,62	8218	2,6	NR372-100L/4a		62		NR220
	76	266	18,45	7887	2,8					
	86	234	16,20	7519	3,0					
	103	196	13,53	7042	3,4					
	112	180	12,48	6839	3,6					
	26	767	54,12	4765	0,8	MR283-100L/4a	5,10	53	108	MR221
	30	658	46,37	5875	0,9	NR283-100L/4a		55		NR221
	33	596	41,96	5849	0,9					
	39	511	35,98	5780	1,0					
	45	438	30,82	5683	1,1					
	55	363	25,23	6832	1,5	MR282-100L/4a	5,10	50	108	MR222
	65	312	21,66	7039	1,6	NR282-100L/4a		54		NR222
	73	275	19,06	6849	1,7					
	83	244	16,91	6547	1,9					
	98	207	14,31	6151	2,1					
	114	177	12,24	5806	2,4					
	132	153	10,57	5500	2,7					
	146	139	9,61	5313	2,9					
	168	121	8,33	5044	3,2					
	38	519	36,55	1423	0,9	MR273-100L/4a	5,10	43	106	MR223
	46	434	30,48	2315	1,0	NR273-100L/4a		45		NR223
	55	364	25,55	2976	1,2					
	65	309	21,43	3470	1,5	MR272-100L/4a	5,10	41	106	MR224
	76	264	18,33	3795	1,7	NR272-100L/4a		43		NR224
	87	232	16,07	3998	1,8					
	99	205	14,21	4140	2,0					
	117	173	11,95	4272	2,3					
	138	147	10,16	4336	2,5					
	161	126	8,71	4204	2,9					
	225	90	6,21	3758	3,7					
	265	77	5,28	3539	3,5					
	57	351	24,77	1150	0,8	MR203-100L/4a	5,10	41	105	MR225
	60	329	23,23	1500	0,8	NR203-100L/4a		43		NR225
	70	289	20,10	3383	0,9	MR202-100L/4a	5,10	41	105	MR226
	74	271	18,85	3566	1,0	NR202-100L/4a		43		NR226
	87	231	16,03	3943	1,1					
	94	214	14,86	4082	1,1					
	101	201	13,92	4186	1,2					
	115	176	12,18	4354	1,3					
	130	156	10,81	4461	1,4					
	139	146	10,07	4506	1,4					
	167	122	8,40	4416	1,6					
	199	102	7,04	4132	1,8					
	241	84	5,80	3911	2,1					
	276	73	5,08	3718	2,2					
	311	65	4,50	3554	2,3					
	333	61	4,20	3462	2,4					
	400	51	3,50	3236	2,5					
	77	263	18,28	2933	0,8	MR172-100L/4a	5,10	31	104	MR227
	82	247	17,14	2909	0,8	NR172-100L/4a		33		NR227
	96	210	14,57	2834	0,9					



Motorlu Güç Devir Sayfaları

Geared Motors Performance Tables

Leistung und Drehzahlübersicht von Getriebemotoren

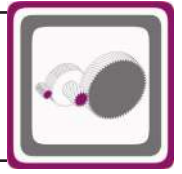

Güç	Çıkış Devri	Çıkış Momenti	Çevrim Oranı	Güv. Rad. Yük Çıkış	Servis Faktörü	Tipi	Anma Akımı	Ağırlık	Ölçü Sayfası	Fiyat Kodu			
Power	Output Speeds	Output Torque	Ratio	Per.O. Loads (Output)	Service Factors	Type	Rated Current	Weight	Dim. Page	Price Ref.			
Leistung P _g [kW] P _g [HP]	Abtriebswelle Drehzahlen n ₂ [r.p.m]	Abtriebswelle Drehmomente M ₂ [Nm]	Übersetzung i	Zul.Querkräfte (Abtrieb) F _{qam} [N]	Betriebsfaktor f _s	Typ	Nennstrom [A]	Gewicht ~ [kg]	Maße Seite	Preis No.			
2,2 3,0	111	183	12,66	2759	1,0	MR172-100L/4a	5,10	31	104	MR227			
	126	160	11,08	2680	1,1	NR172-100L/4a							
	147	138	9,53	2514	1,2								
	157	129	8,94	2479	1,3								
	184	110	7,60	2387	1,5								
	212	96	6,60	2305	1,5								
	242	84	5,78	2226	1,6								
	293	69	4,78	2113	1,9								
	343	59	4,09	2000	2,0								
	414	49	3,38	1895	2,2								
	424	48	6,60	1900	2,6	MR172-90L/2		4,65			28	104	MR228
	485	42	5,78	1825	2,9	NR172-90L/2							
	586	35	4,78	1723	3,2								
	685	30	4,09	1632	3,4								
829	25	3,38	1540	3,5									
3,0 4,0	1,2	22272	1213,85	61087	0,8	MR975-100L/4b	6,45	1125	131	MR374			
	1,3	19872	1082,31	82275	0,9	NR975-100L/4b							
	1,5	16836	914,74	101851	1,1								
	1,7	15503	842,80	108936	1,2								
	1,9	13827	750,24	116879	1,3								
	2,1	12234	662,54	123385	1,5								
	2,4	10893	588,87	128620	1,7								
	2,6	10100	546,94	131761	1,8								
	2,7	9627	510,11	133235	1,9	MR974-100L/4b		6,45			1140	130	MR375
	3,1	8651	457,99	136453	2,1	NR974-100L/4b							
	3,6	7374	390,41	140395	2,4								
	4,1	6508	344,17	142899	2,8								
	4,6	5780	305,33	144903	3,1								
	2,6	10133	345,67	86964	1,3	MR874-132S/6	6,90	605	127	MR229			
						NR874-132S/6		610			NR229		
	3,1	8384	446,42	93930	1,6	MR874-100L/4b	6,45	598	127	MR230			
	3,6	7352	390,74	97675	1,8	NR874-100L/4b							
	4,1	6514	345,67	100430	2,0								
	4,8	5518	292,15	103462	2,4								
	5,8	4530	239,61	106213	2,9								
	6,6	4007	211,60	107571	3,2								
	7,4	3567	188,08	108661	3,6								
	8,0	3307	174,68	109282	3,9								
	9,5	2801	147,61	110614	4,0								
	11	2391	125,70	111557	4,0								
	13	2050	107,60	112313	4,0								
	3,3	7869	418,17	49511	1,0	MR774-100L/4b		6,45			316	124	MR455
	3,9	6797	361,62	53242	1,2	NR774-100L/4b					385		
	4,3	6227	208,82	55042	1,3	MR773-132S/6	6,90	300	123	MR456			
	5,0	5338	178,78	57711	1,5	NR773-132S/6							
6,1	4442	148,73	60064	1,8									
6,8	3978	133,05	61182	2,0									
7,8	3437	115,06	62400	2,3									
9,0	2980	99,63	63361	2,7									
10	2610	87,13	64096	3,1									
12	2303	76,81	64763	3,5									
13	2045	68,15	65248	3,9									



Motorlu Güç Devir Sayfaları

Geared Motors Performance Tables

Leistung und Drehzahlübersicht von Getriebemotoren

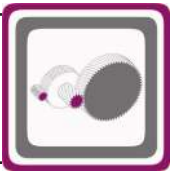

Güç	Çıkış Devri	Çıkış Momenti	Çevrim Oranı	Güv. Rad. Yük Çıkış	Servis Faktörü	Tipi	Anma Akımı	Ağırlık	Ölçü Sayfası	Fiyat Kodu	
Power	Output Speeds	Output Torque	Ratio	Per.O. Loads (Output)	Service Factors	Type	Rated Current	Weight	Dim. Page	Price Ref.	
Leistung P _g [kW] P _g [HP]	Abtriebswelle Drehzahlen n ₂ [r.p.m]	Abtriebswelle Drehmomente M ₂ [Nm]	Übersetzung i	Zul.Querkräfte (Abtrieb) F _{qam} [N]	Betriebsfaktor f _s	Typ	Nennstrom [A]	Gewicht ~ [kg]	Maße Seite	Preis No.	
3,0 4,0	6,0	4454	149,11	25453	1,0	MR673-132S/6	6,90	212	120	MR457	
	7,3	3707	124,07	29598	1,2	NR673-132S/6		214		NR457	
	8,1	3306	110,55	31505	1,3						
	9,6	2814	94,17	33525	1,5						
	11	2423	80,96	34947	1,8						
	13	2105	70,26	36024	2,0						
	15	1843	61,42	36804	2,3						
	17	1622	53,99	37216	2,7						
	17	1581	52,68	36968	2,7						
	20	1361	45,29	35463	3,2						
	23	1183	39,30	34080	3,6						
	26	1036	34,36	32796	4,0						
		8,4	3221	167,32	18287	0,9	MR573-100L/4b	6,45	138	117	MR458
		9,1	2957	153,61	20056	1,0	NR573-100L/4b		132		NR458
		10	2591	134,45	22163	1,2					
		12	2295	118,95	23633	1,3					
		14	1943	100,53	25161	1,5					
		17	1595	82,45	26505	1,9					
		19	1410	72,81	27143	2,1					
		22	1254	64,72	27076	2,4					
		26	1063	54,74	25909	2,8					
		29	948	48,74	25110	3,2					
		35	778	39,98	23769	3,7					
		40	688	35,31	22947	4,0					
		45	612	31,38	22183	4,0					
		15	1771	91,58	11771	0,9	MR473-100L/4b	6,45	103	114	MR239
	16	1674	86,52	13603	0,9	NR473-100L/4b		106		NR239	
	17	1632	84,46	14272	0,9						
	19	1415	73,09	16054	1,1						
	22	1234	63,70	15700	1,3						
	25	1083	55,82	15331	1,4						
	29	952	49,05	14948	1,6						
	33	831	42,75	14523	1,9						
	37	729	37,45	14103	2,1						
	41	676	22,15	13834	2,3	MR472-132S/6	6,90	105	114	MR240	
	48	572	18,72	13286	2,7	NR472-132S/6		108		NR240	
	52	527	17,25	13018	2,8						
	59	469	15,35	12638	3,0						
	26	1026	53,04	6824	0,8	MR373-100L/4b	6,45	63	111	MR241	
	29	929	48,00	6835	0,9	NR373-100L/4b		66		NR241	
	34	796	41,16	6810	1,0						
	40	683	35,25	6740	1,1						
	47	573	29,47	6616	1,3						
	55	491	25,27	6479	1,4						
	60	459	23,33	8211	1,8	MR372-100L/4b	6,45	61	111	MR242	
	68	406	20,62	8382	1,9	NR372-100L/4b		63		NR242	
	76	363	18,45	8035	2,0						
	86	319	16,20	7651	2,2						
	103	267	13,53	7153	2,5						
	112	246	12,48	6942	2,6						
	130	213	10,80	6582	2,9						
	149	186	9,41	6259	3,2						
	170	163	8,25	5965	3,4						



Motorlu Güç Devir Sayfaları

Geared Motors Performance Tables

Leistung und Drehzahlübersicht von Getriebemotoren

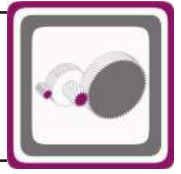

Güç	Çıkış Devri	Çıkış Momenti	Çevrim Oranı	Güv. Rad. Yük Çıkış	Servis Faktörü	Tipi	Anma Akımı	Ağırlık	Ölçü Sayfası	Fiyat Kodu
Power	Output Speeds	Output Torque	Ratio	Per.O. Loads (Output)	Service Factors	Type	Rated Current	Weight	Dim. Page	Price Ref.
Leistung P _g [kW] P _g [HP]	Abtriebswelle Drehzahlen n ₂ [r.p.m]	Abtriebswelle Drehmomente M ₂ [Nm]	Übersetzung i	Zul.Querkräfte (Abtrieb) F _{qam} [N]	Betriebsfaktor f _s	Typ	Nennstrom [A]	Gewicht ~ [kg]	Maße Seite	Preis No.
3,0 4,0	45	598	30,82	5037	0,8	MR283-100L/4b NR283-100L/4b	6,45	55 57	108	MR243 NR243
	55 65 73 83 98 114 132 146 168 194 224 262 303 333 385	496 425 375 333 282 242 209 190 165 143 123 106 91 83 72	25,23 21,66 19,06 16,91 14,31 12,24 10,57 9,61 8,33 7,21 6,25 5,35 4,62 4,20 3,64	4672 5186 5514 5748 5978 5916 5597 5402 5121 4856 4675 4412 4179 4037 3831	1,1 1,2 1,3 1,4 1,6 1,7 2,0 2,1 2,4 2,6 2,9 3,0 3,1 3,1 3,3	MR282-100L/4b NR282-100L/4b	6,45	53 55	108	MR244 NR244
	55	497	25,55	664	0,9	MR273-100L/4b NR273-100L/4b	6,45	45 47	106	MR245 NR245
	65 76 87 99 117 138 161 225 265 309	422 361 317 280 236 201 172 123 105 90	21,43 18,33 16,07 14,21 11,95 10,16 8,71 6,21 5,28 4,53	1.532 2.137 2.544 2.855 3.190 3.416 3.565 3.439 3.490 3.401	1,1 1,2 1,3 1,5 1,7 1,9 2,1 2,7 2,5 2,6	MR272-100L/4b NR272-100L/4b	6,45	44 46	106	MR246 NR246
	87 94 101 115 130 139 167 199 241 276 311 333 400	315 293 274 240 213 199 166 139 114 100 89 83 69	16,03 14,86 13,92 12,18 10,81 10,07 8,40 7,04 5,80 5,08 4,50 4,20 3,50	2143 2413 2622 2986 3247 3375 3632 3795 3420 3509 3560 3536 3299	0,8 0,8 0,9 0,9 1,0 1,1 1,2 1,3 1,5 1,6 1,7 1,7 1,8	MR202-100L/4b NR202-100L/4b	6,45	44 46	105	MR247 NR247
	483 552 622 667 800	57 50 44 41 35	5,80 5,08 4,50 4,20 3,50	3072 2923 2796 2724 2549	2,4 2,5 2,7 2,8 2,9	MR202-100L/2 NR202-100L/2	6,00	42 44	105	MR248 NR248
	111 126 147 157 184 212 242	249 218 188 176 150 130 114	12,66 11,08 9,53 8,94 7,60 6,60 5,78	2537 2501 2332 2313 2256 2197 2137	0,8 0,8 0,9 0,9 1,1 1,1 1,2	MR172-100L/4b NR172-100L/4b	6,45	34 35	104	MR249 NR249



Motorlu Güç Devir Sayfaları

Geared Motors Performance Tables

Leistung und Drehzahlübersicht von Getriebemotoren

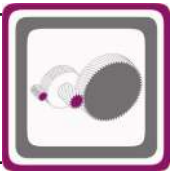

Güç	Çıkış Devri	Çıkış Momenti	Çevrim Oranı	Güv. Rad. Yük Çıkış	Servis Faktörü	Tipi	Anma Akımı	Ağırlık	Ölçü Sayfası	Fiyat Kodu
Power	Output Speeds	Output Torque	Ratio	Per.O. Loads (Output)	Service Factors	Type	Rated Current	Weight	Dim. Page	Price Ref.
Leistung P _g [kW] P _g [HP]	Abtriebswelle Drehzahlen n ₂ [r.p.m]	Abtriebswelle Drehmomente M ₂ [Nm]	Übersetzung i	Zul.Querkräfte (Abtrieb) F _{qam} [N]	Betriebsfaktor f _s	Typ	Nennstrom [A]	Gewicht ~ [kg]	Maße Seite	Preis No.
3,0 4,0	293	95	4,78	2045	1,4	MR172-100L/4b	6,45	34	104	MR249
	343	81	4,09	1934	1,5	NR172-100L/4b		35		NR249
	414	67	3,38	1844	1,6					
	424	65	6,60	1858	1,9	MR172-100L/2	6,00	34	104	MR250
	485	57	5,78	1790	2,1	NR172-100L/2		35		NR250
	586	47	4,78	1696	2,3					
	685	40	4,09	1605	2,5					
	829	33	3,38	1518	2,5					
4,0 5,5	1,7	20671	842,80	75900	0,9	MR975-112M/4	8,20	1130	131	MR376
	1,9	18436	750,24	92220	1,0	NR975-112M/4		1180		NR376
	2,1	16311	662,54	104731	1,1					
	2,4	14524	588,87	113695	1,2					
	2,6	13467	546,94	118464	1,3					
	2,7	12835	510,11	121153	1,4	MR974-112M/4	8,20	1180	130	MR377
	3,1	11535	457,99	126265	1,6	NR974-112M/4		1230		NR377
	3,6	9832	390,41	132758	1,8					
	4,1	8678	344,17	136369	2,1					
	4,6	7707	305,33	139396	2,3					
	5,1	6879	272,24	141842	2,6					
	6,5	5469	216,03	145733	3,3					
	2,6	13511	345,67	69362	1,0	MR874-132M/6a	9,00	620	127	MR251
	3,1	11444	292,15	80864	1,1	NR874-132M/6a		625		NR251
	3,6	9802	390,74	88382	1,3	MR874-112M/4	8,20	616	127	MR252
	4,1	8686	345,67	92818	1,5	NR874-112M/4		621		NR252
	4,8	7357	292,15	97657	1,8					
	5,8	6040	239,61	101906	2,2					
	7,4	4756	188,08	105605	2,7					
	8,0	4410	174,68	106532	2,9					
	8,2	4395	110,17	106569	3,0	MR873-132M/6a	9,00	585	126	MR253
	9,0	3982	99,81	107634	3,3	NR873-132M/6a		590		NR253
	4,3	8310	208,82	47650	1,0	MR773-132M/6a	9,00	322	123	MR459
	5,0	7124	178,78	52136	1,1	NR773-132M/6a		390		NR459
	6,1	5928	148,73	55922	1,3					
	6,8	5309	133,05	57792	1,5					
	7,8	4587	115,06	59702	1,7					
	9,0	3977	99,63	61183	2,0					
	10	3483	87,13	62300	2,3					
	12	3074	76,81	63169	2,6					
	13	2730	68,15	63862	2,9					
	8,0	4493	174,89	25196	1,0	MR673-112M/4	8,20	217	120	MR460
	9,4	3837	149,11	28963	1,1	NR673-112M/4		226		NR460
	11	3194	124,07	31960	1,3					
	13	2849	110,55	33310	1,5					
	15	2459	61,42	34796	1,7	MR673-132M/6a	9,00	217	120	MR461
	17	2164	53,99	36045	2,0	NR673-132M/6a		225		NR461
	17	2110	52,68	35826	2,0					
	20	1817	45,29	34481	2,4					
	23	1579	39,30	33228	2,7					



Motorlu Güç Devir Sayfaları

Geared Motors Performance Tables

Leistung und Drehzahlübersicht von Getriebemotoren



Güç	Çıkış Devri	Çıkış Momenti	Çevrim Oranı	Güv. Rad. Yük Çıkış	Servis Faktörü	Tipi	Anma Akımı	Ağırlık	Ölçü Sayfası	Fiyat Kodu
Power	Output Speeds	Output Torque	Ratio	Per.O. Loads (Output)	Service Factors	Type	Rated Current	Weight	Dim. Page	Price Ref.
Leistung P _g [kW] P _g [HP]	Abtriebswelle Drehzahlen n ₂ [r.p.m]	Abtriebswelle Drehmomente M ₂ [Nm]	Übersetzung i	Zul.Querkräfte (Abtrieb) F _{qam} [N]	Betriebsfaktor f _s	Typ	Nennstrom [A]	Gewicht ~ [kg]	Maße Seite	Preis No.
4,0 5,5	26	1382	34,36	32051	3,1	MR673-132M/6a	9,00	217	120	MR461
	30	1217	30,20	30938	3,5	NR673-132M/6a		225		NR461
	12	3062	118,95	19365	1,0	MR573-112M/4	8,20	142	117	MR462
	14	2592	100,53	22146	1,2	NR573-112M/4		136		NR462
	17	2127	82,45	24375	1,4					
	19	1880	72,81	25391	1,6					
	22	1673	64,72	26066	1,8					
	26	1417	54,74	25055	2,1					
	29	1265	48,74	24349	2,4					
	35	1037	39,98	23145	2,8					
	40	917	35,31	22396	3,0					
	45	816	31,38	21693	3,2					
	52	710	27,00	20811	3,9	MR572-112M/4	8,20	135	117	MR463
	61	606	23,02	19894	4,4	NR572-112M/4		129		NR463
	19	1887	73,09	9049	0,8	MR473-112M/4	8,20	115	114	MR262
	22	1647	63,70	14037	0,9	NR473-112M/4		123		NR262
	25	1444	55,82	14220	1,1					
	29	1270	49,05	13971	1,2					
	33	1109	42,75	13672	1,4					
	37	972	37,45	13358	1,6					
	45	805	30,93	12867	1,9					
	55	669	25,67	12363	2,3					
	63	583	22,15	11952	2,5	MR472-112M/4	8,20	108	114	MR263
	75	493	18,72	11477	2,9	NR472-112M/4		116		NR263
	81	454	17,25	11245	2,9					
	91	404	15,35	10916	3,1					
	40	911	35,25	5904	0,9	MR373-112M/4	8,20	69	111	MR264
	47	765	29,47	5917	1,0	NR373-112M/4		71		NR264
	55	655	25,27	5880	1,1					
	65	562	21,65	5807	1,2					
	68	542	20,62	6315	1,4	MR372-112M/4	8,20	69	111	MR265
	76	485	18,45	6666	1,5	NR372-112M/4		72		NR265
	86	426	16,20	6983	1,7					
	103	356	13,53	7282	1,9					
	112	328	12,48	7067	2,0					
	130	285	10,80	6691	2,2					
	149	248	9,41	6355	2,4					
	170	218	8,25	6050	2,6					
	205	181	6,84	5693	3,1					
	73	500	19,06	3474	1,0	MR282-112M/4	8,20	62	108	MR266
	83	444	16,91	3939	1,1	NR282-112M/4		64		NR266
	98	376	14,31	4447	1,2					
	114	322	12,24	4796	1,3					
	132	279	10,57	5032	1,5					
	146	254	9,61	5144	1,6					
	168	220	8,33	5215	1,8					
	194	190	7,21	4938	1,9					
	224	165	6,25	4769	2,2					
	262	141	5,35	4493	2,3					
	303	122	4,62	4249	2,3					
	333	111	4,20	4101	2,3					
	385	96	3,64	3887	2,5					

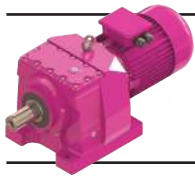

Motorlu Güç Devir Sayfaları

Geared Motors Performance Tables

Leistung und Drehzahlübersicht von Getriebemotoren



Güç	Çıkış Devri	Çıkış Momenti	Çevrim Oranı	Güv. Rad. Yük Çıkış	Servis Faktörü	Tipi	Anma Akımı	Ağırlık	Ölçü Sayfası	Fiyat Kodu	
Power	Output Speeds	Output Torque	Ratio	Per.O. Loads (Output)	Service Factors	Type	Rated Current	Weight	Dim. Page	Price Ref.	
Leistung P _g [kW] P _g [HP]	Abtriebswelle Drehzahlen n ₂ [r.p.m]	Abtriebswelle Drehmomente M ₂ [Nm]	Übersetzung i	Zul.Querkräfte (Abtrieb) F _{qam} [N]	Betriebsfaktor f _s	Typ	Nennstrom [A]	Gewicht ~ [kg]	Maße Seite	Preis No.	
4,0 5,5	444	83	3,15	3686	2,6	MR282-112M/4 NR282-112M/4	8,20	62 64	108	MR266 NR266	
	524	71	5,35	3470	3,7	MR282-112M/2 NR282-112M/2	7,80	62 64	108	MR267 NR267	
	74	492	19,00	-	0,9	MR273-112M/4 NR273-112M/4	8,20	52 54	106	MR268 NR268	
	87	423	16,07	727	1,0	MR272-112M/4 NR272-112M/4	8,20	52 54	106	MR269 NR269	
	99	374	14,21	1.248	1,1						
	117	315	11,95	1.839	1,2						
	138	268	10,16	2.267	1,4						
	161	230	8,71	2.581	1,6						
	225	164	6,21	2.643	2,0						
	265	140	5,28	2.813	1,9						
309	120	4,53	2.924	1,9							
4,0 5,5	451	82	6,21	3.007	3,4	MR272-112M/2 NR272-112M/2	7,80	52 54	106	MR270 NR270	
	530	70	5,28	2.830	2,8						
	619	60	4,53	2.672	3,0						
	130	284	10,81	1730	0,8	MR202-112M/4 NR202-112M/4	8,20	52 54	105	MR271 NR271	
	139	265	10,07	1961	0,8						
	167	221	8,40	2453	0,9						
	199	186	7,04	2807	1,0						
	241	153	5,80	2448	1,1						
	276	134	5,08	2658	1,2						
	311	119	4,50	2805	1,3						
4,0 5,5	333	111	4,20	2875	1,3						
	400	92	3,50	3008	1,4						
	483	76	5,80	3085	1,8	MR202-112M/2 NR202-112M/2	7,80	50 52	105	MR272 NR272	
	552	67	5,08	2979	1,9						
	622	59	4,50	2846	2,0						
	667	55	4,20	2771	2,1						
	800	46	3,50	2588	2,2						
	212	174	6,60	2033	0,8	MR172-112M/4 NR172-112M/4	8,20	42 44	104	MR273 NR273	
	242	153	5,78	2002	0,9						
	293	126	4,78	1942	1,0						
4,0 5,5	343	108	4,09	1837	1,1						
	414	90	3,38	1769	1,2						
	424	87	6,60	1797	1,4	MR172-112M/2 NR172-112M/2	7,80	41 43	104	MR274 NR274	
	485	76	5,78	1740	1,6						
	586	63	4,78	1656	1,7						
	685	54	4,09	1567	1,9						
	829	45	3,38	1489	1,9						
	5,5 7,5	2,1	22428	662,54	59449	0,8	MR975-132S/4 NR975-132S/4	11,30	1150	131	MR378 NR378
		2,4	19970	588,87	81598	0,9			1200		
		2,6	18517	546,94	91692	1,0					
5,5 7,5	2,7	17649	510,11	97133	1,0	MR974-132S/4 NR974-132S/4	11,30	1200 1250	130	MR379 NR379	



Motorlu Güç Devir Sayfaları

Geared Motors Performance Tables

Leistung und Drehzahlübersicht von Getriebemotoren

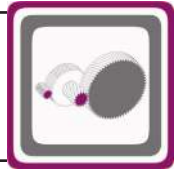

Güç	Çıkış Devri	Çıkış Momenti	Çevrim Oranı	Güv. Rad. Yük Çıkış	Servis Faktörü	Tipi	Anma Akımı	Ağırlık	Ölçü Sayfası	Fiyat Kodu
Power	Output Speeds	Output Torque	Ratio	Per.O. Loads (Output)	Service Factors	Type	Rated Current	Weight	Dim. Page	Price Ref.
Leistung P _g [kW] P _g [HP]	Abtriebswelle Drehzahlen n ₂ [r.p.m]	Abtriebswelle Drehmomente M ₂ [Nm]	Übersetzung i	Zul.Querkräfte (Abtrieb) F _{qam} [N]	Betriebsfaktor f _s	Typ	Nennstrom [A]	Gewicht ~ [kg]	Maße Seite	Preis No.
5,5 7,5	3,1	15861	457,99	107107	1,1	MR974-132S/4	11,30	1200	130	MR379
	3,6	13519	390,41	118239	1,3	NR974-132S/4		1250		NR379
	4,1	11932	344,17	124658	1,5					
	4,6	10597	305,33	129922	1,7					
	5,1	9458	272,24	133804	1,9					
	6,5	7519	216,03	139960	2,4					
	7,2	6735	193,13	142255	2,7					
	8,1	6012	172,08	144275	3,0					
	4,1	11943	345,67	78321	1,1	MR874-132S/4	11,30	615	127	MR275
	4,8	10116	292,15	87040	1,3	NR874-132S/4		620		NR275
	5,8	8305	239,61	94212	1,6					
	6,6	7346	211,60	97693	1,8					
	7,4	6540	188,08	100351	2,0					
	8,0	6063	174,68	101836	2,1					
	9,5	5136	147,61	104555	2,5					
	11	4383	125,70	106602	3,0					
	6,1	8157	148,73	48271	1,0	MR773-132M/6b NR773-132M/6b	12,30	322 390	123	MR464 NR464
	6,7	7375	208,82	51187	1,1	MR773-132S/4	11,30	320	123	MR465
	7,8	6323	178,78	54748	1,3	NR773-132S/4		388		NR465
	9,4	5263	148,73	57919	1,5					
	11	4713	133,05	59380	1,7					
	12	4073	115,06	60959	2,0					
	14	3532	99,63	62193	2,3					
	16	3093	87,13	63130	2,6					
	18	2730	76,81	63862	2,9					
	21	2425	68,15	64448	3,3					
	11	4392	124,07	25835	1,0	MR673-132S/4	11,30	231	120	MR466
	13	3917	110,55	28527	1,1	NR673-132S/4		241		NR466
	15	3335	94,17	31336	1,3					
	17	2871	80,96	33271	1,5					
	20	2495	70,26	32989	1,7					
	23	2184	61,42	31985	2,0					
	26	1922	53,99	31011	2,2					
	27	1875	52,68	30824	2,3					
	31	1614	45,29	29677	2,6					
	36	1403	39,30	28606	2,8					
	41	1228	34,36	27599	3,1					
	46	1081	30,20	26647	3,4					
	17	2925	82,45	20253	1,0	MR573-132S/4	11,30	159	117	MR467
	19	2586	72,81	22170	1,2	NR573-132S/4		153		NR467
	22	2301	64,72	23581	1,3					
	26	1949	54,74	23774	1,5					
	29	1739	48,74	23208	1,7					
	35	1426	39,98	22209	2,0					
	40	1261	35,31	21569	2,2					
	45	1122	31,38	20958	2,4					
	52	976	27,00	20179	2,8	MR572-132S/4	11,30	150	117	MR468
	61	834	23,02	19355	3,2	NR572-132S/4		143		NR468
	52	976	27,00	20179	2,8					
	61	834	23,02	19355	3,2					
	73	694	19,15	18419	3,6					
	82	619	17,07	17842	4,0					



Motorlu Güç Devir Sayfaları

Geared Motors Performance Tables

Leistung und Drehzahlübersicht von Getriebemotoren

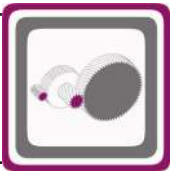

Güç	Çıkış Devri	Çıkış Momenti	Çevrim Oranı	Güv. Rad. Yük Çıkış	Servis Faktörü	Tipi	Anma Akımı	Ağırlık	Ölçü Sayfası	Fiyat Kodu
Power	Output Speeds	Output Torque	Ratio	Per.O. Loads (Output)	Service Factors	Type	Rated Current	Weight	Dim. Page	Price Ref.
Leistung P _g [kW] P _g [HP]	Abtriebswelle Drehzahlen n ₂ [r.p.m]	Abtriebswelle Drehmomente M ₂ [Nm]	Übersetzung i	Zul.Querkräfte (Abtrieb) F _{qam} [N]	Betriebsfaktor f _s	Typ	Nennstrom [A]	Gewicht ~ [kg]	Maße Seite	Preis No.
5,5 7,5	25	1986	55,82	5759	0,8	MR473-132S/4	11,30	126	114	MR283
	29	1747	49,05	12507	0,9	NR473-132S/4		128		NR283
	33	1524	42,75	12396	1,0					
	37	1337	37,45	12239	1,2					
	45	1106	30,93	11944	1,4					
	55	920	25,67	11596	1,7					
	63	801	22,15	11291	1,8	MR472-132S/4	11,30	121	114	MR284
	75	678	18,72	10918	2,1	NR472-132S/4		124		NR284
	81	624	17,25	10730	2,1					
	91	556	15,35	10457	2,2					
103	492	13,56	10161	2,5						
116	437	12,05	9878	2,7						
130	391	10,79	9554	2,8						
147	346	9,53	9261	3,0						
55	901	25,27	4981	0,8	MR373-132S/4	11,30	80	111	MR285	
65	773	21,65	5037	0,8	NR373-132S/4		82		NR285	
68	737	20,64	4872	0,9						
75	668	18,68	4891	1,0						
86	586	16,20	4498	1,2	MR372-132S/4	11,30	80	111	MR286	
103	490	13,53	5207	1,4	NR372-132S/4		82		NR286	
112	452	12,48	5457	1,4						
130	391	10,80	5815	1,6						
149	341	9,41	6062	1,7						
170	299	8,25	6174	1,9						
205	248	6,84	5812	2,3						
235	217	5,97	5516	2,4						
268	190	5,23	5247	2,7						
282	180	4,96	5214	2,6						
326	156	4,29	4935	2,8						
374	136	3,74	4685	3,0						
298	170	9,41	5003	2,7	MR372-132S/2a	11,00	78	111	MR287	
340	149	8,25	4766	2,9	NR372-132S/2a		80		NR287	
409	124	6,84	4484	3,5						
469	108	5,97	4264	3,9						
536	95	5,23	4064	4,0						
565	90	4,96	4022	4,0						
653	78	4,29	3816	4,0						
749	68	3,74	3630	4,0						
98	517	14,31	2151	0,9	MR282-132S/4	11,30	73	108	MR288	
114	443	12,24	2830	0,9	NR282-132S/4		75		NR288	
132	383	10,57	3336	1,1						
146	349	9,61	3601	1,1						
168	302	8,33	3924	1,3						
194	262	7,21	4168	1,4						
224	227	6,25	3730	1,6						
262	194	5,35	3944	1,6						
303	168	4,62	4082	1,7						
333	153	4,20	4143	1,7						
385	132	3,64	3970	1,8						
444	115	3,15	3758	1,9						
524	97	5,35	3532	2,7	MR282-132S/2a	11,00	72	108	MR289	
607	84	4,62	3343	2,7	NR282-132S/2a		74		NR289	
667	76	4,20	3228	2,8						
769	66	3,64	3062	2,9						



Motorlu Güç Devir Sayfaları

Geared Motors Performance Tables

Leistung und Drehzahlübersicht von Getriebemotoren

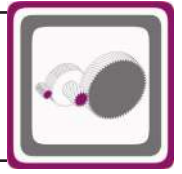

Güç	Çıkış Devri	Çıkış Momenti	Çevrim Oranı	Güv. Rad. Yük Çıkış	Servis Faktörü	Tipi	Anma Akımı	Ağırlık	Ölçü Sayfası	Fiyat Kodu
Power	Output Speeds	Output Torque	Ratio	Per.O. Loads (Output)	Service Factors	Type	Rated Current	Weight	Dim. Page	Price Ref.
Leistung P _g [kW] P _g [HP]	Abtriebswelle Drehzahlen n ₂ [r.p.m]	Abtriebswelle Drehmomente M ₂ [Nm]	Übersetzung i	Zul.Querkräfte (Abtrieb) F _{qam} [N]	Betriebsfaktor f _s	Typ	Nennstrom [A]	Gewicht ~ [kg]	Maße Seite	Preis No.
5,5 7,5	889	57	3,15	2905	3,0	MR282-132S/2a NR282-132S/2a	11,00	72 74	108	MR289 NR289
7,5 10	3,1 3,6 4,1 4,6	21629 18434 16271 14450	457,99 390,41 344,17 305,33	67448 92230 104950 114036	0,8 1,0 1,1 1,2	MR974-132M/4 NR974-132M/4	15,30	1155 1205	130	MR380 NR380
	4,8 5,4 6,0 6,8 7,7 8,8 9,8 11	14013 12512 11270 9969 8732 7729 6899 6200	186,95 166,73 150,02 132,83 116,17 102,69 91,56 82,20	116163 122481 127342 132036 136178 139314 141978 143851	1,3 1,4 1,6 1,8 2,1 2,3 2,6 2,9	MR973-160M/6 NR973-160M/6	15,20	1090 1140	129	MR381 NR381
	4,8 5,8 6,6 7,4 8,0	13794 11325 10018 8918 8268	292,15 239,61 211,60 188,08 174,68	67557 81452 87464 91940 94346	0,9 1,1 1,3 1,5 1,6	MR874-132M/4 NR874-132M/4	15,30	615 620	127	MR290 NR290
	8,2 9,0 10 12 14 16	8241 7466 6471 5649 4846 4230	110,17 99,81 86,51 75,51 64,77 56,54	94440 97282 100567 103078 105361 107001	1,6 1,7 2,0 2,3 2,7 3,1	MR873-160M/6 NR873-160M/6	15,20	610 615	126	MR291 NR291
	7,8 9,4 11 12 14 16 18 21	8625 7179 6429 5555 4818 4219 3724 3307	178,78 148,73 133,05 115,06 99,63 87,13 76,81 68,15	46319 51946 54421 57099 59111 60609 61765 62679	0,9 1,1 1,2 1,4 1,7 1,9 2,1 2,4	MR773-132M/4 NR773-132M/4	15,30	344 430	123	MR469 NR469
	15 17 20 23 26 27 31 36 41 46	4549 3916 3403 2979 2622 2557 2202 1914 1676 1475	94,17 80,96 70,26 61,42 53,99 52,68 45,29 39,30 34,36 30,20	24784 28529 30966 30273 29506 29356 28415 27511 26642 25805	0,9 1,1 1,3 1,4 1,6 1,7 1,9 2,1 2,3 2,5	MR673-132M/4 NR673-132M/4	15,30	233 244	120	MR470 NR470
	60 68	1144 1025	23,18 20,74	24094 23382	3,2 3,5	MR672-132M/4 NR672-132M/4	15,30	228 238	120	MR471 NR471
	22 26 29 35 40 45	3138 2659 2372 1946 1721 1531	64,72 54,74 48,74 39,98 35,31 31,38	18872 21782 21687 20961 20467 19979	1,0 1,1 1,3 1,5 1,6 1,7	MR573-132M/4 NR573-132M/4	15,30	167 160	117	MR472 NR472



Motorlu Güç Devir Sayfaları

Geared Motors Performance Tables

Leistung und Drehzahlübersicht von Getriebemotoren

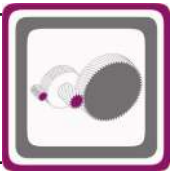

Güç	Çıkış Devri	Çıkış Momenti	Çevrim Oranı	Güv. Rad. Yük Çıkış	Servis Faktörü	Tipi	Anma Akımı	Ağırlık	Ölçü Sayfası	Fiyat Kodu
Power	Output Speeds	Output Torque	Ratio	Per.O. Loads (Output)	Service Factors	Type	Rated Current	Weight	Dim. Page	Price Ref.
Leistung P _g [kW] P _g [HP]	Abtriebswelle Drehzahlen n ₂ [r.p.m]	Abtriebswelle Drehmomente M ₂ [Nm]	Übersetzung i	Zul.Querkräfte (Abtrieb) F _{qam} [N]	Betriebsfaktor f _s	Typ	Nennstrom [A]	Gewicht ~ [kg]	Maße Seite	Preis No.
7,5 10	52	1332	27,00	19336	2,1	MR572-132M/4	15,30	160	117	MR473
	61	1137	23,02	18637	2,3	NR572-132M/4		153		NR473
	73	946	19,15	17822	2,7					
	82	844	17,07	17309	2,9					
	96	718	14,54	16600	3,3					
	112	619	12,50	15939	3,8					
	37	1824	37,45	10749	0,8	MR473-132M/4	15,30	133	114	MR298
	45	1509	30,93	10713	1,0	NR473-132M/4		136		NR298
	55	1255	25,67	10574	1,2					
	63	1093	22,15	10409	1,3	MR472-132M/4	15,30	130	114	MR299
75	925	18,72	10173	1,6	NR472-132M/4		133		NR299	
81	852	17,25	10044	1,5						
91	759	15,35	9846	1,6						
103	671	13,56	9622	1,8						
116	597	12,05	9398	2,0						
130	534	10,79	9104	2,1						
147	472	9,53	8863	2,2						
165	420	8,47	8630	2,4						
178	389	7,87	8482	2,6						
211	329	6,65	8143	3,0						
86	799	16,20	1186	0,9	MR372-132M/4	15,30	91	111	MR301	
103	668	13,53	2440	1,0	NR372-132M/4		93		NR301	
112	616	12,48	2905	1,1						
130	534	10,80	3606	1,2						
149	466	9,41	4138	1,3						
170	409	8,25	4542	1,4						
205	339	6,84	4534	1,7						
235	296	5,97	4806	1,8						
268	259	5,23	4998	2,0						
298	233	9,41	5098	2,0	MR372-132S/2b	14,60	81	111	MR302	
340	204	8,25	4850	2,2	NR372-132S/2b		83		NR302	
409	170	6,84	4565	2,5						
469	148	5,97	4335	2,8						
536	130	5,23	4127	3,1						
565	123	4,96	4095	3,1						
653	107	4,29	3878	3,3						
749	93	3,74	3685	3,5						
855	81	3,28	3510	3,7						
132	523	10,57	1074	0,8	MR282-132M/4	15,30	83	108	MR303	
146	476	9,61	1543	0,8	NR282-132M/4		85		NR303	
168	412	8,33	2141	0,9						
194	357	7,21	2624	1,0						
224	309	6,25	2169	1,2						
262	265	5,35	2607	1,2						
303	229	4,62	2929	1,2						
333	208	4,20	3094	1,2						
385	180	3,64	3291	1,3						
444	156	3,15	3434	1,4						
524	132	5,35	3541	2,0	MR282-132S/2b	14,60	83	108	MR304	
607	114	4,62	3412	2,0	NR282-132S/2b		85		NR304	
667	104	4,20	3291	2,0						
769	90	3,64	3117	2,1						
889	78	3,15	2953	2,2						



Motorlu Güç Devir Sayfaları

Geared Motors Performance Tables

Leistung und Drehzahlübersicht von Getriebemotoren

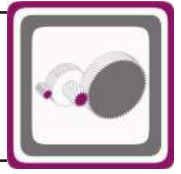

Güç	Çıkış Devri	Çıkış Momenti	Çevrim Oranı	Güv. Rad. Yük Çıkış	Servis Faktörü	Tipi	Anma Akımı	Ağırlık	Ölçü Sayfası	Fiyat Kodu
Power	Output Speeds	Output Torque	Ratio	Per.O. Loads (Output)	Service Factors	Type	Rated Current	Weight	Dim. Page	Price Ref.
Leistung P _g [kW] P _g [HP]	Abtriebswelle Drehzahlen n ₂ [r.p.m]	Abtriebswelle Drehmomente M ₂ [Nm]	Übersetzung i	Zul.Querkräfte (Abtrieb) F _{qam} [N]	Betriebsfaktor f _s	Typ	Nennstrom [A]	Gewicht ~ [kg]	Maße Seite	Preis No.
11 15	4,8	20564	186,95	76718	0,9	MR973-160L/6	22,00	1131	129	MR382
	5,4	18361	166,73	92705	1,0	NR973-160L/6		1181		NR382
	6,8	14630	132,83	113278	1,2					
	7,5	13265	186,95	119565	1,4	MR973-160M/4	21,50	1108	129	MR383
	8,4	11845	166,73	125147	1,5	NR973-160M/4		1158		NR383
	9,3	10670	150,02	129764	1,7					
	11	9439	132,83	133986	1,9					
	12	8269	116,17	137718	2,2					
	14	7319	102,69	140569	2,5					
	15	6533	91,56	142817	2,8					
	17	5872	82,20	144822	3,1					
	8,2	12087	110,17	77560	1,1	MR873-160L/6	22,00	650	126	MR305
	9,0	10951	99,81	83256	1,2	NR873-160L/6		655		NR305
	10	9491	86,51	89670	1,4					
	12	8285	75,51	94284	1,6					
	14	7107	64,77	98501	1,8					
	13	7770	110,17	96072	1,7	MR873-160M/4	21,50	645	126	MR306
	14	7040	99,81	98725	1,8	NR873-160M/4		650		NR306
	16	6102	86,51	101718	2,1					
	19	5326	75,51	104015	2,4					
	22	4569	64,77	106110	2,8					
	25	3988	56,54	107619	3,3					
	26	3728	52,86	108779	3,5					
		11	9431	133,05	42683	0,8	MR773-160M/4	21,50	413	123
12		8150	115,06	48302	1,0	NR773-160M/4		505		NR474
14		7067	99,63	52331	1,1					
16		6190	87,13	55154	1,3					
18		5463	76,81	57361	1,5					
21		4852	68,15	59020	1,6					
23		4331	60,76	60618	1,8					
24		4173	58,59	60735	1,9					
28		3619	50,75	62020	2,2					
32		3154	44,17	63029	2,5					
36		2816	39,33	63719	2,8					
40		2501	34,89	64337	3,2					
45		2233	31,11	64843	3,6					
47	2151	30,00	64993	3,7						
	23	4370	61,42	25961	1,0	MR673-160M/4	21,50	282	120	MR475
	26	3847	53,99	26872	1,1	NR673-160M/4		295		NR475
	27	3752	52,68	26786	1,1					
	31	3231	45,29	26206	1,3					
	36	2808	39,30	25594	1,4					
	41	2458	34,36	24966	1,6					
	46	2164	30,20	24332	1,7					
	53	1913	26,66	23696	1,8					
	60	1679	23,18	22963	2,2	MR672-160M/4	21,50	280	120	MR476
	68	1504	20,74	22371	2,4	NR672-160M/4		290		NR476
	78	1299	17,93	21593	2,7					
	90	1126	15,53	20821	3,0					
	103	986	13,58	20106	3,3					
	117	870	11,97	19439	3,6					



Motorlu Güç Devir Sayfaları

Geared Motors Performance Tables

Leistung und Drehzahlübersicht von Getriebemotoren

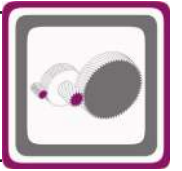

Güç	Çıkış Devri	Çıkış Momenti	Çevrim Oranı	Güv. Rad. Yük Çıkış	Servis Faktörü	Tipi	Anma Akımı	Ağırlık	Ölçü Sayfası	Fiyat Kodu
Power	Output Speeds	Output Torque	Ratio	Per.O. Loads (Output)	Service Factors	Type	Rated Current	Weight	Dim. Page	Price Ref.
Leistung P _g [kW] P _g [HP]	Abtriebswelle Drehzahlen n ₂ [r.p.m]	Abtriebswelle Drehmomente M ₂ [Nm]	Übersetzung i	Zul.Querkräfte (Abtrieb) F _{qam} [N]	Betriebsfaktor f _s	Typ	Nennstrom [A]	Gewicht ~ [kg]	Maße Seite	Preis No.
11 15	35	2854	39,98	18777	1,0	MR573-160M/4	21,50	213	117	MR477
	40	2524	35,31	18539	1,1	NR573-160M/4		205		NR477
	45	2246	31,38	18265	1,2					
	53	1903	26,54	17812	1,3					
	61	1668	23,02	17380	1,6	MR572-160M/4	21,50	210	117	MR478
	73	1389	19,15	16775	1,8	NR572-160M/4		202		NR478
	82	1239	17,07	16377	2,0					
	96	1054	14,54	15806	2,3					
	112	908	12,50	15257	2,6					
	129	789	10,85	14737	2,9					
	148	690	9,48	14244	3,2					
	168	607	8,34	13773	3,6					
	189	540	7,41	13252	4,0					
	64	1557	21,74	8645	1,0	MR473-160M/4	21,50	182	114	MR313
	78	1294	18,04	8672	1,2	NR473-160M/4		184		NR313
81	1249	17,25	8842	1,0	MR472-160M/4	21,50	180	114	MR314	
91	1114	15,35	8777	1,1	NR472-160M/4		182		NR314	
103	984	13,56	8677	1,2						
116	876	12,05	8559	1,3						
130	783	10,79	8317	1,4						
147	692	9,53	8168	1,5						
165	616	8,47	8012	1,7						
178	571	7,87	7909	1,8						
211	483	6,65	7658	2,0						
247	412	5,66	7405	2,2						
287	356	4,89	7041	2,2						
309	330	4,54	6928	2,1						
365	280	3,83	6666	2,3						
429	238	3,27	6404	2,5						
15 20	6,8	19953	132,83	81953	0,9	MR973-180L/6	29,00	1187	129	MR384
						NR973-180L/6		1237		NR384
	7,5	18091	186,95	94405	1,0	MR973-160L/4	29,00	1140	129	MR385
	8,4	16155	166,73	105558	1,1	NR973-160L/4		1190		NR385
	9,3	14552	150,02	113609	1,2					
	11	12874	132,83	121059	1,4					
	12	11277	116,17	127373	1,6					
	14	9982	102,69	132035	1,8					
	15	8911	91,56	135622	2,0					
	17	8009	82,20	138467	2,2					
	20	6830	70,07	142012	2,6					
	23	6029	61,77	144077	3,0					
	26	5355	54,80	146026	3,4					
	8,2	16483	110,17	46009	0,8	MR873-180L/6	29,00	655	126	MR315
	9,0	14933	99,81	59313	0,9	NR873-180L/6		660		NR315
10	12943	86,51	72798	1,0						
12	11298	75,51	81586	1,2						
13	10596	110,17	84902	1,2	MR873-160L/4	29,00	615	126	MR316	
14	9600	99,81	89226	1,4	NR873-160L/4		620		NR316	
16	8320	86,51	94158	1,6						
19	7263	75,51	97976	1,8						
22	6230	64,77	101322	2,1						
25	5438	56,54	103692	2,4						



Motorlu Güç Devir Sayfaları

Geared Motors Performance Tables

Leistung und Drehzahlübersicht von Getriebemotoren

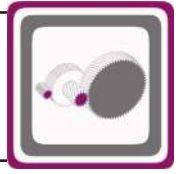

Güç	Çıkış Devri	Çıkış Momenti	Çevrim Oranı	Güv. Rad. Yük Çıkış	Servis Faktörü	Tipi	Anma Akımı	Ağırlık	Ölçü Sayfası	Fiyat Kodu	
Power	Output Speeds	Output Torque	Ratio	Per.O. Loads (Output)	Service Factors	Type	Rated Current	Weight	Dim. Page	Price Ref.	
Leistung P _g [kW] P _g [HP]	Abtriebswelle Drehzahlen n ₂ [r.p.m]	Abtriebswelle Drehmomente M ₂ [Nm]	Übersetzung i	Zul.Querkräfte (Abtrieb) F _{qam} [N]	Betriebsfaktor f _s	Typ	Nennstrom [A]	Gewicht ~ [kg]	Maße Seite	Preis No.	
15 20	26	5084	52,86	105493	2,6	MR873-160L/4	29,00	615	126	MR316	
	30	4436	46,12	106902	2,9	NR873-160L/4		620		NR316	
	35	3900	40,55	108032	3,3						
	14	9639	99,63	41586	0,8	MR773-160L/4	29,00	406	123	MR479	
	16	8442	87,13	47100	0,9	NR773-160L/4		490		NR479	
	18	7451	76,81	50943	1,1						
	21	6618	68,15	53824	1,2						
	23	5907	60,76	56400	1,4						
	24	5691	58,59	56702	1,4						
	28	4937	50,75	58795	1,6						
	32	4302	44,17	60399	1,9						
	36	3840	39,33	61480	2,1						
	40	3411	34,89	62435	2,3						
	45	3045	31,11	63208	2,6						
	47	2934	30,00	63432	2,7						
	54	2545	25,99	64276	3,1						
	62	2218	22,62	64903	3,6						
	65	2115	21,40	65074	3,8	MR772-160L/4 NR772-160L/4	29,00	376 460	123	MR480 NR480	
	31	4406	45,29	23681	0,9	MR673-160L/4 NR673-160L/4	29,00	305 317	120	MR481 NR481	
	36	3830	39,30	23403	1,0						
	41	3353	34,36	23050	1,1						
	46	2951	30,20	22648	1,2						
	53	2609	26,66	22209	1,4						
	60	2290	23,18	21671	1,6	MR672-160L/4 NR672-160L/4	29,00	300 312	120	MR482 NR482	
	68	2051	20,74	21215	1,7						
	78	1772	17,93	20593	2,0						
	90	1536	15,53	19955	2,2						
	103	1345	13,58	19349	2,4						
	117	1187	11,97	18772	2,7						
	132	1054	10,62	18222	2,9						
	148	941	9,47	17696	3,2						
	153	906	9,13	17529	3,3						
	177	786	7,91	16876	3,7						
	45	3064	31,38	16306	0,9	MR573-160L/4 NR573-160L/4	29,00	251 242	117	MR483 NR483	
	53	2596	26,54	16155	1,0						
		61	2275	23,02	15943	1,2	MR572-160L/4 NR572-160L/4	29,00	245 237	117	MR484 NR484
		73	1894	19,15	15580	1,3					
		82	1689	17,07	15311	1,5					
		96	1438	14,54	14899	1,7					
112		1238	12,50	14476	1,9						
129		1076	10,85	14060	2,1						
148		941	9,48	13652	2,3						
168		828	8,34	13253	2,6						
189		736	7,41	12754	3,0						
218		640	6,43	12326	3,3						
249		560	5,63	11919	3,5						
283		493	4,95	11529	3,9						
321		435	4,37	11156	4,0						
		78	1765	18,04	7168	0,9	MR473-160L/4 NR473-160L/4	29,00	202 205	114	MR323 NR323



Motorlu Güç Devir Sayfaları

Geared Motors Performance Tables

Leistung und Drehzahlübersicht von Getriebemotoren

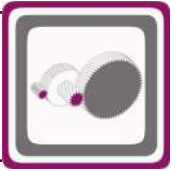

Güç	Çıkış Devri	Çıkış Momenti	Çevrim Oranı	Güv. Rad. Yük Çıkış	Servis Faktörü	Tipi	Anma Akımı	Ağırlık	Ölçü Sayfası	Fiyat Kodu
Power	Output Speeds	Output Torque	Ratio	Per.O. Loads (Output)	Service Factors	Type	Rated Current	Weight	Dim. Page	Price Ref.
Leistung P _g [kW] P _g [HP]	Abtriebswelle Drehzahlen n ₂ [r.p.m]	Abtriebswelle Drehmomente M ₂ [Nm]	Übersetzung i	Zul.Querkräfte (Abtrieb) F _{qam} [N]	Betriebsfaktor f _s	Typ	Nennstrom [A]	Gewicht ~ [kg]	Maße Seite	Preis No.
15 20	81	1704	17,25	7469	0,8	MR472-160L/4	29,00	200	114	MR324
	91	1519	15,35	7555	0,8	NR472-160L/4		203		NR324
	103	1343	13,56	7598	0,9					
	116	1195	12,05	7599	1,0					
	130	1068	10,79	7418	1,0					
	147	944	9,53	7374	1,1					
	165	840	8,47	7306	1,2					
	178	779	7,87	7253	1,3					
	211	659	6,65	7104	1,5					
	247	562	5,66	6933	1,6					
	287	486	4,89	6588	1,6					
	309	451	4,54	6507	1,6					
	365	382	3,83	6310	1,7					
429	325	3,27	6110	1,8						
18,5 25	8,4	19925	166,73	81754	0,9	MR973-180M/4	36,00	1160	129	MR386
	9,3	17949	150,02	95286	1,0	NR973-180M/4		1210		NR386
	11	15879	132,83	107016	1,1					
	12	13910	116,17	116530	1,3					
	14	12312	102,69	123314	1,5					
	15	10991	91,56	128406	1,6					
	17	9879	82,20	132373	1,8					
	20	8424	70,07	137243	2,1					
	23	7436	61,77	140202	2,4					
	26	6605	54,80	142613	2,7					
	29	5896	48,86	144582	3,1					
	33	5109	42,30	146652	3,5					
	12	13934	75,51	66643	0,9	MR873-200L/6a	36,00	705	126	MR325
	14	11952	64,77	78272	1,1	NR873-200L/6a		710		NR325
	16	10262	86,51	86402	1,3	MR873-180M/4	36,00	660	126	MR326
	19	8958	75,51	91786	1,5	NR873-180M/4		665		NR326
	22	7684	64,77	96363	1,7					
	25	6707	56,54	99813	1,9					
	26	6270	52,86	102280	2,1					
	30	5471	46,12	104193	2,4					
	35	4810	40,55	105716	2,7					
	18	9190	76,81	43763	0,9	MR773-180M/4	36,00	423	123	MR485
	21	8162	68,15	48251	1,0	NR773-180M/4		515		NR485
23	7286	60,76	51573	1,1						
24	7020	58,59	52505	1,1						
28	6089	50,75	55514	1,3						
32	5306	44,17	57777	1,5						
36	4737	39,33	59279	1,7						
40	4207	34,89	60587	1,9						
45	3756	31,11	61632	2,1						
47	3619	30,00	61939	2,2						
54	3139	25,99	63056	2,5						
62	2736	22,62	63888	2,9						
65	2609	21,40	64116	3,1	MR772-180M/4	36,00	418	123	MR486	
75	2274	18,63	64753	3,5	NR772-180M/4		510		NR486	
36	4724	39,30	21486	0,8	MR673-180M/4	36,00	314	120	MR487	
41	4135	34,36	21375	0,9	NR673-180M/4		328		NR487	
46	3640	30,20	21174	1,0						
53	3218	26,66	20909	1,1						



Motorlu Güç Devir Sayfaları

Geared Motors Performance Tables

Leistung und Drehzahlübersicht von Getriebemotoren

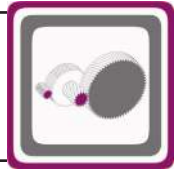

Güç	Çıkış Devri	Çıkış Momenti	Çevrim Oranı	Güv. Rad. Yük Çıkış	Servis Faktörü	Tipi	Anma Akımı	Ağırlık	Ölçü Sayfası	Fiyat Kodu	
Power	Output Speeds	Output Torque	Ratio	Per.O. Loads (Output)	Service Factors	Type	Rated Current	Weight	Dim. Page	Price Ref.	
Leistung P _g [kW] P _g [HP]	Abtriebswelle Drehzahlen n ₂ [r.p.m]	Abtriebswelle Drehmomente M ₂ [Nm]	Übersetzung i	Zul.Querkräfte (Abtrieb) F _{qam} [N]	Betriebsfaktor f _s	Typ	Nennstrom [A]	Gewicht ~ [kg]	Maße Seite	Preis No.	
18,5 25	60	2825	23,18	20540	1,3	MR672-180M/4	36,00	311	120	MR488	
	68	2530	20,74	20204	1,4	NR672-180M/4		325		NR488	
	78	2185	17,93	19719	1,6						
	90	1895	15,53	19198	1,8						
	103	1660	13,58	18686	2,0						
	117	1465	11,97	18188	2,2						
	132	1301	10,62	17704	2,4						
	148	1161	9,47	17234	2,6						
	153	1118	9,13	17084	2,7						
	177	970	7,91	16490	3,0						
	203	845	6,88	15916	3,4						
	244	704	5,73	14984	4,0						
		73	2336	19,15	14534	1,1	MR572-180M/4	36,00	262	117	MR489
		82	2084	17,07	14379	1,2	NR572-180M/4		250		NR489
		96	1773	14,54	14104	1,3					
		112	1527	12,50	13794	1,5					
		129	1327	10,85	13468	1,7					
		148	1161	9,48	13134	1,9					
		168	1022	8,34	12798	2,1					
		189	908	7,41	12318	2,4					
		218	789	6,43	11948	2,6					
		249	691	5,63	11588	2,9					
		283	608	4,95	11239	3,1					
		321	537	4,37	10899	3,4					
		103	1656	13,56	6653	0,7	MR472-180M/4	36,00	242	114	MR333
		116	1474	12,05	6760	0,8	NR472-180M/4		245		NR333
		130	1318	10,79	6630	0,8					
		147	1165	9,53	6679	0,9					
		165	1036	8,47	6688	1,0					
		178	961	7,87	6679	1,1					
		211	813	6,65	6619	1,2					
		247	693	5,66	6520	1,3					
		287	600	4,89	6191	1,3					
	309	556	4,54	6139	1,3						
	365	471	3,83	5999	1,4						
	429	401	3,27	5845	1,5						
22 30	11	18884	132,83	89201	1,0	MR973-180L/4	42,00	1185	129	MR387	
	12	16542	116,17	103474	1,1	NR973-180L/4		1235		NR387	
	14	14643	102,69	113137	1,2						
	15	13071	91,56	120169	1,4						
	17	11749	82,20	125527	1,5						
	20	10018	70,07	131991	1,8						
	23	8844	61,77	135846	2,0						
	26	7855	54,80	139151	2,3						
	29	7012	48,86	141455	2,6						
	33	6076	42,30	144081	3,0						
	38	5364	37,29	146088	3,4						
		12	16570	75,51	44950	0,8	MR873-200L/6b	43,00	720	126	MR334
		14	14214	64,77	64907	0,9	NR873-200L/6b		725		NR334
		16	12203	86,51	76942	1,1	MR873-180L/4	42,00	660	126	MR335
		19	10652	75,51	84645	1,2	NR873-180L/4		665		NR335
		22	9137	64,77	91003	1,4					
		25	7976	56,54	95370	1,6					
		26	7457	52,86	98737	1,7					
		30	6505	46,12	101231	2,0					
		35	5720	40,55	103200	2,3					



Motorlu Güç Devir Sayfaları

Geared Motors Performance Tables

Leistung und Drehzahlübersicht von Getriebemotoren

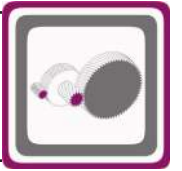

Güç	Çıkış Devri	Çıkış Momenti	Çevrim Oranı	Güv. Rad. Yük Çıkış	Servis Faktörü	Tipi	Anma Akımı	Ağırlık	Ölçü Sayfası	Fiyat Kodu	
Power	Output Speeds	Output Torque	Ratio	Per.O. Loads (Output)	Service Factors	Type	Rated Current	Weight	Dim. Page	Price Ref.	
Leistung P _g [kW] P _g [HP]	Abtriebswelle Drehzahlen n ₂ [r.p.m]	Abtriebswelle Drehmomente M ₂ [Nm]	Übersetzung i	Zul.Querkräfte (Abtrieb) F _{qam} [N]	Betriebsfaktor f _s	Typ	Nennstrom [A]	Gewicht ~ [kg]	Maße Seite	Preis No.	
22 30	23	8665	60,76	46142	0,9	MR773-180L/4	42,00	462	123	MR490	
	24	8348	58,59	47488	1,0	NR773-180L/4		560		NR490	
	28	7242	50,75	51720	1,1						
	32	6310	44,17	54810	1,3						
	36	5633	39,33	56824	1,4						
	40	5004	34,89	58553	1,6						
	45	4467	31,11	60014	1,8						
	47	4304	30,00	60418	1,9						
	54	3734	25,99	61744	2,1						
	62	3254	22,62	62806	2,5						
		65	3103	21,40	63096	2,6	MR772-180L/4	42,00	430	123	MR491
		75	2705	18,63	63897	3,0	NR772-180L/4		530		NR491
		85	2382	16,39	65101	3,2					
		96	2115	14,54	66117	3,5					
		46	4329	30,20	19701	0,8	MR673-180L/4	42,00	343	120	MR492
		53	3827	26,66	19608	0,9	NR673-180L/4		357		NR492
		60	3359	23,18	19410	1,1	MR672-180L/4	42,00	318	120	MR493
		68	3008	20,74	19192	1,2	NR672-180L/4		322		NR493
		78	2599	17,93	18844	1,3					
		90	2254	15,53	18441	1,5					
		103	1974	13,58	18024	1,6					
		117	1742	11,97	17604	1,8					
		132	1547	10,62	17186	2,0					
		148	1380	9,47	16772	2,2					
		153	1330	9,13	16639	2,2					
		177	1153	7,91	16105	2,5					
		203	1005	6,88	15580	2,9					
		244	837	5,73	14671	3,8					
		275	743	5,08	14242	3,9					
		309	663	4,53	13831	4,0					
		320	639	4,37	13702	4,0					
		370	554	3,79	13192	4,0					
		73	2778	19,15	13488	0,9	MR572-180L/4	42,00	284	117	MR494
		82	2478	17,07	13447	1,0	NR572-180L/4		271		NR494
		96	2109	14,54	13310	1,1					
		112	1816	12,50	13111	1,3					
	129	1578	10,85	12875	1,4						
	148	1381	9,48	12616	1,6						
	168	1215	8,34	12342	1,8						
	189	1080	7,41	11882	2,0						
	218	939	6,43	11569	2,2						
	249	822	5,63	11257	2,4						
	283	723	4,95	10948	2,6						
	321	639	4,37	10642	2,9						
	147	1385	9,53	5984	0,8	MR472-180L/4	42,00	242	114	MR341	
	165	1233	8,47	6071	0,8	NR472-180L/4		244		NR341	
	178	1143	7,87	6105	0,9						
	211	967	6,65	6134	1,0						
	247	825	5,66	6107	1,1						
	287	714	4,89	5794	1,1						
	309	662	4,54	5770	1,1						
	365	560	3,83	5688	1,2						
	429	477	3,27	5580	1,2						



Motorlu Güç Devir Sayfaları

Geared Motors Performance Tables

Leistung und Drehzahlübersicht von Getriebemotoren

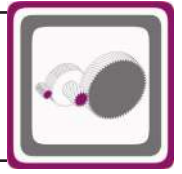

Güç	Çıkış Devri	Çıkış Momenti	Çevrim Oranı	Güv. Rad. Yük Çıkış	Servis Faktörü	Tipi	Anma Akımı	Ağırlık	Ölçü Sayfası	Fiyat Kodu	
Power	Output Speeds	Output Torque	Ratio	Per.O. Loads (Output)	Service Factors	Type	Rated Current	Weight	Dim. Page	Price Ref.	
Leistung P _g [kW] P _g [HP]	Abtriebswelle Drehzahlen n ₂ [r.p.m]	Abtriebswelle Drehmomente M ₂ [Nm]	Übersetzung i	Zul.Querkräfte (Abtrieb) F _{qam} [N]	Betriebsfaktor f _s	Typ	Nennstrom [A]	Gewicht ~ [kg]	Maße Seite	Preis No.	
30 40	14	19969	102,69	81478	0,9	MR973-200L/4	54,00	1240	129	MR388	
	15	17825	91,56	96243	1,0	NR973-200L/4		1290		NR388	
	17	16022	82,20	106261	1,1						
	20	13662	70,07	117776	1,3						
	23	12060	61,77	124360	1,5						
	26	10712	54,80	129423	1,7						
	29	9563	48,86	133453	1,9						
	33	8287	42,30	137606	2,2						
	38	7316	37,29	140677	2,5						
	42	6498	33,08	142940	2,8						
	47	5801	29,49	144827	3,1						
		19	14526	75,51	62750	0,9	MR873-200L/4	54,00	746	126	MR342
		22	12460	64,77	75541	1,0	NR873-200L/4		751		NR342
		25	10877	56,54	83605	1,2					
	26	10168	52,86	86813	1,3						
	30	8871	46,12	92157	1,5						
	35	7800	40,55	96044	1,7						
	41	6642	34,53	100037	2,0						
	46	5840	30,36	102452	2,2						
	51	5270	27,39	104225	2,5						
	59	4592	23,87	106099	2,8						
	69	3900	20,28	107929	3,3						
	79	3429	17,83	106358	3,8						
	87	3094	16,09	104176	4,0						
	100	2696	14,02	101201	4,0						
	36	7682	39,33	50060	1,0	MR773-200L/4	54,00	497	123	MR495	
	40	6824	34,89	53080	1,2	NR773-200L/4		600		NR495	
	45	6092	31,11	55518	1,3						
	47	5869	30,00	56189	1,4						
	54	5092	25,99	58392	1,6						
	62	4437	22,62	60091	1,8						
	65	4232	21,40	60516	1,9	MR772-200L/4	54,00	465	123	MR496	
	75	3689	18,63	61869	2,2	NR772-200L/4		570		NR496	
	85	3249	16,39	63380	2,4						
	96	2885	14,54	64703	2,6						
	108	2579	12,98	65799	2,8						
	120	2317	11,65	66674	3,0						
	127	2186	11,00	67105	3,1						
	146	1913	9,62	67999	3,4						
	78	3545	17,93	16845	1,0	MR672-200L/4	54,00	386	120	MR497	
	90	3074	15,53	16710	1,1	NR672-200L/4		380		NR497	
	103	2692	13,58	16510	1,2						
	117	2376	11,97	16270	1,3						
	132	2110	10,62	16002	1,5						
	148	1883	9,47	15716	1,6						
	153	1814	9,13	15621	1,6						
	177	1573	7,91	15223	1,9						
	203	1370	6,88	14813	2,1						
	244	1142	5,73	13954	2,8						
	275	1014	5,08	13606	2,9						
	309	905	4,53	13265	3,0						
	320	872	4,37	13155	3,1						
	370	756	3,79	12719	3,2						
	425	658	3,29	12293	3,3						
	96	2876	14,54	11495	0,8	MR572-200L/4	54,00	304	117	MR498	
						NR572-200L/4		291		NR498	



Motorlu Güç Devir Sayfaları

Geared Motors Performance Tables

Leistung und Drehzahlübersicht von Getriebemotoren

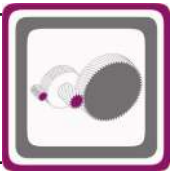

Güç	Çıkış Devri	Çıkış Momenti	Çevrim Oranı	Güv. Rad. Yük Çıkış	Servis Faktörü	Tipi	Anma Akımı	Ağırlık	Ölçü Sayfası	Fiyat Kodu	
Power	Output Speeds	Output Torque	Ratio	Per.O. Loads (Output)	Service Factors	Type	Rated Current	Weight	Dim. Page	Price Ref.	
Leistung P _g [kW] P _g [HP]	Abtriebswelle Drehzahlen n ₂ [r.p.m]	Abtriebswelle Drehmomente M ₂ [Nm]	Übersetzung i	Zul.Querkräfte (Abtrieb) F _{qam} [N]	Betriebsfaktor f _s	Typ	Nennstrom [A]	Gewicht ~ [kg]	Maße Seite	Preis No.	
30 40	112	2476	12,50	11551	0,9	MR572-200L/4	54,00	304	117	MR498	
	129	2152	10,85	11521	1,0	NR572-200L/4		291		NR498	
	148	1883	9,48	11432	1,2						
	168	1657	8,34	11302	1,3						
	189	1473	7,41	10885	1,5						
	218	1280	6,43	10704	1,6						
	249	1120	5,63	10501	1,8						
	283	986	4,95	10283	1,9						
	321	871	4,37	10055	2,1						
37 50	17	19762	82,20	82795	0,9	MR973-225S/4	66,00	1210	129	MR389	
	20	16851	70,07	101879	1,1	NR973-225S/4		1260		NR389	
	23	14875	61,77	112106	1,2						
	26	13213	54,80	119585	1,4						
	29	11794	48,86	125123	1,5						
	33	10221	42,30	131180	1,8						
	38	9023	37,29	135390	2,0						
	42	8015	33,08	138490	2,2						
	47	7155	29,49	141031	2,5						
	54	6311	26,03	143463	2,9						
	61	5571	22,95	145274	3,2						
		30	10941	46,12	83317	1,2	MR873-225S/4	66,00	770	126	MR347
		35	9620	40,55	89134	1,4	NR873-225S/4		775		NR347
		41	8192	34,53	94707	1,6					
		46	7203	30,36	98202	1,8					
		51	6499	27,39	100495	2,0					
		59	5664	23,87	102985	2,3					
		69	4810	20,28	104887	2,7					
	79	4229	17,83	102724	3,1						
	87	3816	16,09	100898	3,4						
	100	3326	14,02	98344	3,9						
	105	3155	13,30	103377	4,0						
	40	8417	34,89	47122	1,0	MR773-225S/4	66,00	534	123	MR499	
	45	7513	31,11	50750	1,1	NR773-225S/4		645		NR499	
	47	7239	30,00	51741	1,1						
	54	6280	25,99	54937	1,3						
	62	5473	22,62	57341	1,5						
	72	4723	19,52	59824	1,7						
	80	4216	17,40	61758	1,8						
	96	3558	14,54	63347	2,1	MR772-225S/4	66,00	525	123	MR500	
	108	3181	12,98	64680	2,2	NR772-225S/4		635		NR500	
	120	2858	11,65	65733	2,4						
	127	2696	11,00	66253	2,5						
	146	2360	9,62	67312	2,7						
	166	2077	8,46	67693	3,0						
	193	1785	7,26	64701	2,7						
	215	1604	6,52	62492	2,8						
	117	2930	11,97	15102	1,1	MR672-225S/4	66,00	410	120	MR501	
	132	2602	10,62	14966	1,2	NR672-225S/4		426		NR501	
	148	2322	9,47	14793	1,3						
	153	2237	9,13	14730	1,3						
	177	1940	7,91	14451	1,5						
	203	1690	6,88	14142	1,7						
	244	1408	5,73	13327	2,3						
	275	1251	5,08	13050	2,3						
	309	1116	4,53	12769	2,4						



Motorlu Güç Devir Sayfaları

Geared Motors Performance Tables

Leistung und Drehzahlübersicht von Getriebemotoren

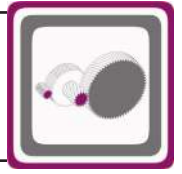

Güç	Çıkış Devri	Çıkış Momenti	Çevrim Oranı	Güv. Rad. Yük Çıkış	Servis Faktörü	Tipi	Anma Akımı	Ağırlık	Ölçü Sayfası	Fiyat Kodu
Power	Output Speeds	Output Torque	Ratio	Per.O. Loads (Output)	Service Factors	Type	Rated Current	Weight	Dim. Page	Price Ref.
Leistung P _g [kW] P _g [HP]	Abtriebswelle Drehzahlen n ₂ [r.p.m]	Abtriebswelle Drehmomente M ₂ [Nm]	Übersetzung i	Zul.Querkräfte (Abtrieb) F _{qam} [N]	Betriebsfaktor f _s	Typ	Nennstrom [A]	Gewicht ~ [kg]	Maße Seite	Preis No.
37	320	1075	4,37	12677	2,5	MR672-225S/4	66,00	410	120	MR501
50	370	932	3,79	12304	2,6	NR672-225S/4		426		NR501
	425	812	3,29	11933	2,6					
45	23	18092	61,77	94418	1,0	MR973-225M/4	80,00	1173	129	MR390
60	26	16070	54,80	106045	1,1	NR973-225M/4		1223		NR390
	29	14345	48,86	114532	1,3					
	33	12432	42,30	122976	1,4					
	38	10975	37,29	128625	1,6					
	42	9749	33,08	132877	1,8					
	47	8703	29,49	136296	2,1					
	54	7676	26,03	139517	2,3					
	61	6776	22,95	141913	2,7					
	69	6020	20,36	144229	3,0					
	77	5374	18,15	141977	3,3					
	30	13307	46,12	70637	1,0	MR873-225M/4	80,00	784	126	MR352
	35	11700	40,55	79584	1,1	NR873-225M/4		788		NR352
	41	9964	34,53	87496	1,3					
	46	8760	30,36	92580	1,5					
	51	7905	27,39	95583	1,6					
	59	6888	23,87	99211	1,9					
	69	5850	20,28	100164	2,2					
	79	5144	17,83	98572	2,5					
	87	4641	16,09	97151	2,8					
	100	4045	14,02	95079	3,2					
	105	3837	13,30	101584	3,4					
	121	3344	11,59	98365	3,8					
	139	2973	10,09	96488	3,9	MR872-225M/4	80,00	780	126	MR353
	158	2614	8,87	93356	4,0	NR872-225M/4		784		NR353
	185	2226	7,55	84341	4,0					
	211	1957	6,64	81967	4,0					
	234	1766	5,99	80064	4,0					
	268	1539	5,22	77518	4,0					
	283	1460	4,95	78695	4,0					
	324	1272	4,32	75895	4,0					
	54	7639	25,99	50279	1,0	MR773-225M/4	80,00	540	123	MR502
	62	6657	22,62	53732	1,2	NR773-225M/4		650		NR502
	72	5744	19,52	57102	1,4					
	80	5128	17,40	59551	1,5					
	96	4328	14,54	61653	1,7	MR772-225M/4	80,00	530	123	MR503
	108	3869	12,98	63292	1,8	NR772-225M/4		640		NR503
	120	3477	11,65	64577	2,0					
	127	3280	11,00	65202	2,1					
	146	2870	9,62	66474	2,3					
	166	2526	8,46	67417	2,5					
	193	2172	7,26	65103	2,2					
	215	1951	6,52	62854	2,3					
	227	1841	6,15	61691	2,4					
	117	3564	11,97	13767	0,9	MR672-225M/4	80,00	420	120	MR504
	132	3165	10,62	13782	1,0	NR672-225M/4		435		NR504
	148	2824	9,47	13737	1,1					
	153	2721	9,13	13712	1,1					
	177	2360	7,91	13569	1,2					
	203	2056	6,88	13374	1,4					



Motorlu Güç Devir Sayfaları

Geared Motors Performance Tables

Leistung und Drehzahlübersicht von Getriebemotoren

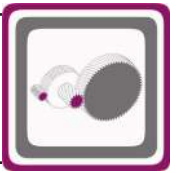

Güç	Çıkış Devri	Çıkış Momenti	Çevrim Oranı	Güv. Rad. Yük Çıkış	Servis Faktörü	Tipi	Anma Akımı	Ağırlık	Ölçü Sayfası	Fiyat Kodu
Power	Output Speeds	Output Torque	Ratio	Per.O. Loads (Output)	Service Factors	Type	Rated Current	Weight	Dim. Page	Price Ref.
Leistung P _g [kW] P _g [HP]	Abtriebswelle Drehzahlen n ₂ [r.p.m]	Abtriebswelle Drehmomente M ₂ [Nm]	Übersetzung i	Zul.Querkräfte (Abtrieb) F _{qam} [N]	Betriebsfaktor f _s	Typ	Nennstrom [A]	Gewicht ~ [kg]	Maße Seite	Preis No.
45 60	244	1713	5,73	12611	1,9	MR672-225M/4	80,00	420	120	MR504
	275	1521	5,08	12415	1,9	NR672-225M/4		435		NR504
	309	1357	4,53	12202	2,0					
	320	1308	4,37	12131	2,0					
	370	1134	3,79	11831	2,1					
	425	988	3,29	11521	2,2					
55 75	26	19642	54,80	83858	0,9	MR973-250M/4	97,00	1400	129	MR391
	29	17534	48,86	97827	1,0	NR973-250M/4		1450		NR391
	33	15194	42,30	110470	1,2					
	38	13414	37,29	118877	1,3					
	42	11916	33,08	124955	1,5					
	47	10637	29,49	129714	1,7					
	54	9382	26,03	134009	1,9					
	61	8283	22,95	137623	2,2					
	69	7358	20,36	140412	2,4					
	77	6569	18,15	139669	2,7					
	86	5922	16,23	136969	3,0	MR972-250M/4	97,00	1360	129	MR392
	97	5260	14,40	132890	3,4	NR972-250M/4		1410		NR392
	41	12178	34,53	76957	1,1	MR873-250M/4	97,00	865	126	MR358
	46	10707	30,36	84377	1,2	NR873-250M/4		870		NR358
	51	9661	27,39	88876	1,3					
	59	8419	23,87	93915	1,5					
	69	7150	20,28	94261	1,8					
	79	6287	17,83	93382	2,1					
	87	5673	16,09	92468	2,3					
	100	4944	14,02	90998	2,6					
	105	4690	13,30	99344	2,8					
121	4087	11,59	96412	3,1						
139	3633	10,09	95090	3,2	MR872-250M/4	97,00	860	126	MR359	
158	3195	8,87	92126	3,5	NR872-250M/4		865		NR359	
185	2721	7,55	82142	3,9						
211	2392	6,64	80033	4,0						
234	2158	5,99	78319	4,0						
268	1881	5,22	75997	4,0						
283	1784	4,95	77730	4,0						
324	1555	4,32	75054	4,0						
62	8137	22,62	48314	1,0	MR773-250M/4	97,00	582	123	MR505	
72	7021	19,52	53143	1,1	NR773-250M/4		710		NR505	
80	6268	17,40	56422	1,2						
96	5290	14,54	59396	1,4	MR772-250M/4	97,00	552	123	MR506	
108	4729	12,98	61384	1,5	NR772-250M/4		680		NR506	
120	4249	11,65	63000	1,6						
127	4009	11,00	63779	1,7						
146	3508	9,62	65344	1,8						
166	3087	8,46	66568	2,0						
193	2654	7,26	65358	1,8						
215	2385	6,52	63304	1,9						
227	2250	6,15	62117	1,9						
75 97	38	18293	37,29	93140	1,0	MR973-280S/4	133,00	1530	129	MR393
	42	16250	33,08	105016	1,1	NR973-280S/4		1580		NR393
	47	14506	29,49	113816	1,2					



Motorlu Güç Devir Sayfaları

Geared Motors Performance Tables

Leistung und Drehzahlübersicht von Getriebemotoren

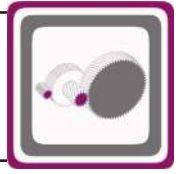

Güç	Çıkış Devri	Çıkış Momenti	Çevrim Oranı	Güv. Rad. Yük Çıkış	Servis Faktörü	Tipi	Anma Akımı	Ağırlık	Ölçü Sayfası	Fiyat Kodu
Power	Output Speeds	Output Torque	Ratio	Per.O. Loads (Output)	Service Factors	Type	Rated Current	Weight	Dim. Page	Price Ref.
Leistung P _g [kW] P _g [HP]	Abtriebswelle Drehzahlen n ₂ [r.p.m]	Abtriebswelle Drehmomente M ₂ [Nm]	Übersetzung i	Zul.Querkräfte (Abtrieb) F _{qam} [N]	Betriebsfaktor f _s	Typ	Nennstrom [A]	Gewicht ~ [kg]	Maße Seite	Preis No.
75 97	54	12794	26,03	121329	1,4	MR973-280S/4	133,00	1530	129	MR393
	61	11295	22,95	127274	1,6	NR973-280S/4		1580		NR393
	69	10034	20,36	131735	1,8					
	77	8958	18,15	135053	2,0					
	86	8076	16,23	133222	2,2	MR972-280S/4	133,00	1490	129	MR394
	97	7173	14,40	129566	2,5	NR972-280S/4		1540		NR394
	109	6414	12,86	126123	2,8					
	121	5767	11,56	122866	3,1					
	140	4987	9,99	117608	2,5					
	158	4430	8,86	114158	2,6					
	177	3961	7,92	110940	2,7					
	197	3561	7,11	107918	2,8					
	51	13174	27,39	71425	1,0	MR873-280S/4	133,00	910	126	MR362
	59	11481	23,87	80962	1,1	NR873-280S/4		915		NR362
	69	9751	20,28	82454	1,3					
	79	8573	17,83	83001	1,5					
	87	7736	16,09	83101	1,7					
	100	6741	14,02	82835	1,9					
	105	6395	13,30	94863	2,0					
	121	5573	11,59	92507	2,3					
	139	4955	10,09	92292	2,3	MR872-280S/4	133,00	905	126	MR363
	158	4356	8,87	89666	2,6	NR872-280S/4		910		NR363
	185	3710	7,55	77743	2,9					
	211	3262	6,64	76166	3,1					
	234	2943	5,99	74829	3,4					
	268	2565	5,22	72956	3,7					
	283	2433	4,95	75799	3,7					
	324	2120	4,32	73372	4,0					
90 117	47	17408	29,49	98535	1,0	MR973-280M/4	158,00	1530	129	MR395
	54	15353	26,03	109691	1,2	NR973-280M/4		1580		NR395
	61	13555	22,95	117935	1,3					
	69	12042	20,36	124168	1,5					
	77	10750	18,15	129274	1,7					
	86	9691	16,23	130412	1,9	MR972-280M/4	158,00	1490	129	MR396
	97	8609	14,40	127072	2,1	NR972-280M/4		1540		NR396
	109	7698	12,86	123895	2,3					
	121	6921	11,56	120865	2,6					
	140	5985	9,99	115703	2,1					
	158	5316	8,86	112468	2,2					
	177	4754	7,92	109430	2,3					
	197	4274	7,11	106562	2,3					
	69	11701	20,28	73599	1,1	MR873-280M/4	158,00	930	126	MR364
	79	10288	17,83	75215	1,3	NR873-280M/4		935		NR364
	87	9283	16,09	76076	1,4					
	100	8089	14,02	76713	1,6					
	105	7674	13,30	91502	1,7					
	121	6688	11,59	89579	1,9					
	139	5946	10,09	90193	1,9	MR872-280M/4	158,00	925	126	MR365
	158	5227	8,87	87821	2,1	NR872-280M/4		930		NR365
	185	4452	7,55	74444	2,4					
	211	3914	6,64	73265	2,6					
	234	3532	5,99	72212	2,8					



Motorlu Güç Devir Sayfaları

Geared Motors Performance Tables

Leistung und Drehzahlübersicht von Getriebemotoren

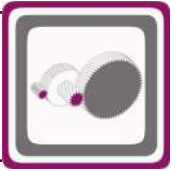

Güç	Çıkış Devri	Çıkış Momenti	Çevrim Oranı	Güv. Rad. Yük Çıkış	Servis Faktörü	Tipi	Anma Akımı	Ağırlık	Ölçü Sayfası	Fiyat Kodu
Power	Output Speeds	Output Torque	Ratio	Per.O. Loads (Output)	Service Factors	Type	Rated Current	Weight	Dim. Page	Price Ref.
Leistung P _g [kW] P _g [HP]	Abtriebswelle Drehzahlen n ₂ [r.p.m]	Abtriebswelle Drehmomente M ₂ [Nm]	Übersetzung i	Zul.Querkräfte (Abtrieb) F _{qam} [N]	Betriebsfaktor f _s	Typ	Nennstrom [A]	Gewicht ~ [kg]	Maße Seite	Preis No.
90 117	268	3078	5,22	70675	3,1	MR872-280M/4	158,00	925	126	MR365
	283	2920	4,95	74351	3,1	NR872-280M/4		930		NR365
	324	2545	4,32	72110	3,4					
110 150	61	16568	22,95	103339	1,1	MR973-315S/4	195,00	1740	129	MR397
	69	14718	20,36	112723	1,2	NR973-315S/4		1790		NR397
	77	13139	18,15	119791	1,4					
	86	11845	16,23	125147	1,5	MR972-315S/4	195,00	1700	129	MR398
	97	10522	14,40	123748	1,7	NR972-315S/4		1750		NR398
	109	9409	12,86	120925	1,9					
	121	8459	11,56	118197	2,1					
	140	7316	9,99	113163	1,7					
	158	6498	8,86	110214	1,8					
	177	5810	7,92	107416	1,8					
197	5224	7,11	104753	1,9						
132 180	69	17662	20,36	96909	1,0	MR973-315M/4a	235,00	1845	129	MR399
	77	15768	18,15	107572	1,1	NR973-315M/4a		1895		NR399
	86	14215	16,23	115049	1,3	MR972-315M/4a	235,00	1805	129	MR400
	97	12627	14,40	120091	1,4	NR972-315M/4a		1855		NR400
	109	11291	12,86	117659	1,6					
	121	10151	11,56	115262	1,8					
	140	8779	9,99	110369	1,4					
	158	7798	8,86	107735	1,5					
	177	6973	7,92	105202	1,5					
	197	6269	7,11	102764	1,6					
160 218	97	15306	14,40	109891	1,2	MR972-315M/4b	280,00	1885	129	MR401
	109	13686	12,86	113501	1,3	NR972-315M/4b		1935		NR401
	121	12305	11,56	111527	1,5					
	140	10642	9,99	106813	1,2					
	158	9453	8,86	104580	1,2					
	177	8452	7,92	102383	1,3					
	197	7599	7,11	100232	1,3					

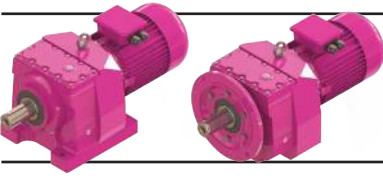

Ölçü Sayfaları

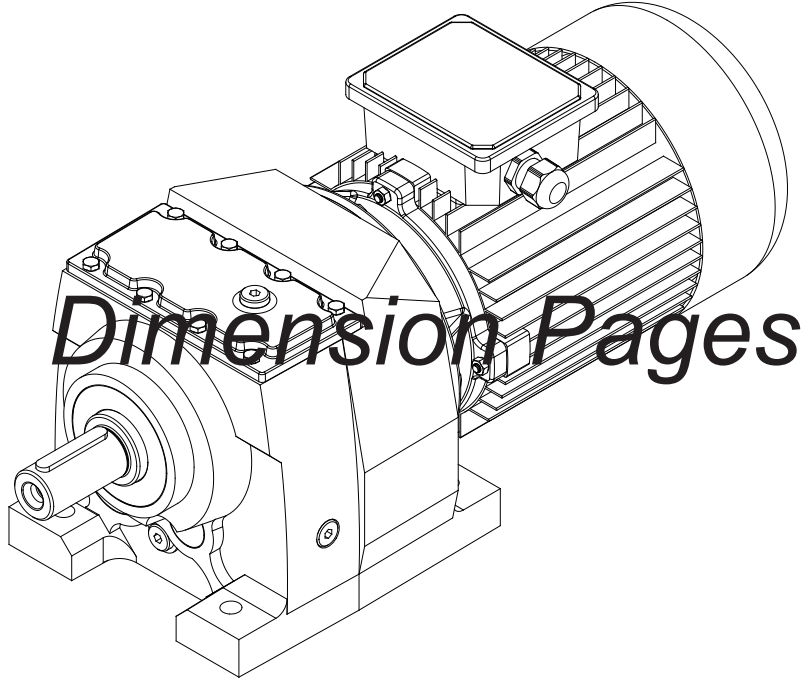

Abmessungsseiten

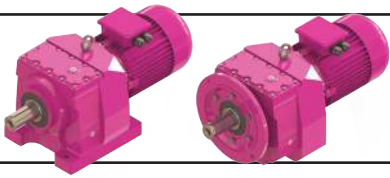

Ölçü Sayfaları Dimension Pages Abmessungsseiten



-Mil ucu çekirme deliği DIN 332 sayfa 2 / Tapped center hole to DIN 332, sheet 2 / Zentrierung mit gewinde DIN 332, Blatt 2

MR002 MR003

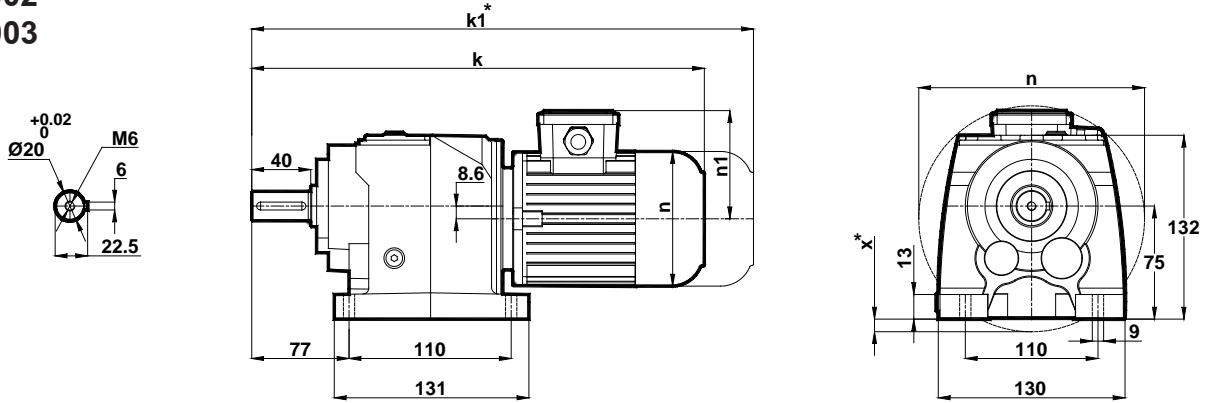

NR002 NR003

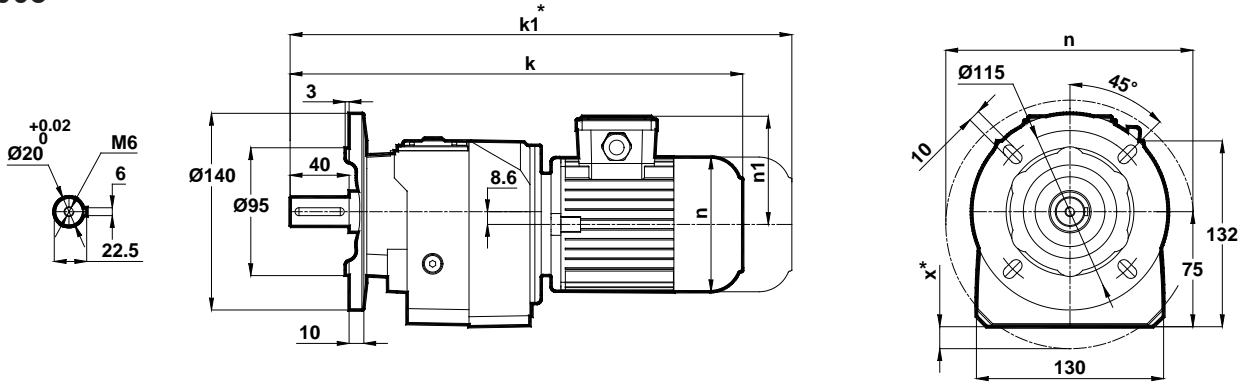

Motor Büyüklüğü / Motor Size / Motorbaugroße					
	63	71	80	90S	90L
k	368	387	415	443	483
k1	421	507	535	568	608
n	121	138	156	176	176
n1	97	111	118	126	126
x	-	5	14	24	24

Klemens Kutusu / Terminal Box / Klemmenkasten

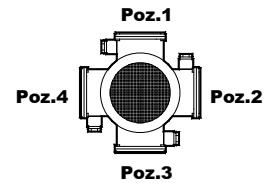

63-71-80-90

Opsiyonel Flanş Ölçüleri / Optional Flange Dimensions / Auswählbare Flanschabmessungen

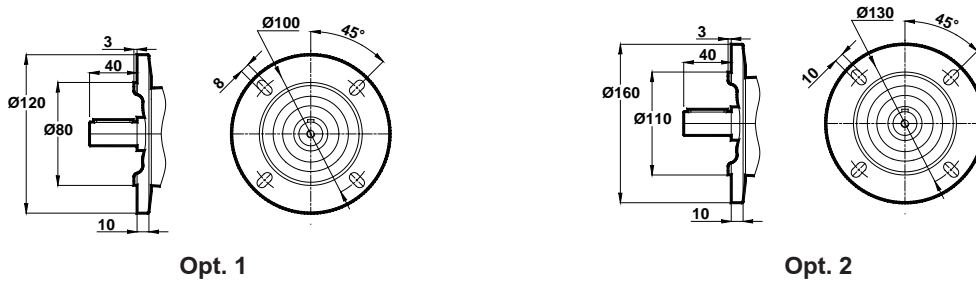

* " k1 " Ölçüsü frenli redüktörlere aittir. Dimension " k1 " is for motors with brake. Maße " k1 " ist für Bremsenmotoren.

x: Motor, ayak bağlantı yüzeyinin altında ise / x: If Motor is lower then foot mounting plane / x: Wenn motor ist niedriger den die Anschlußplatte

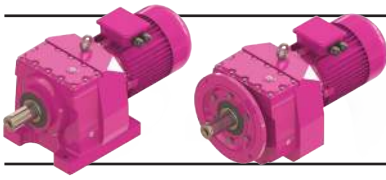

Ölçü Sayfaları Dimension Pages Abmessungsseiten



-Mil ucu çektirme deliği DIN 332 sayfa 2 / Tapped center hole to DIN 332, sheet 2 / Zentrierung mit gewinde DIN 332, Blatt 2

MR102
MR103

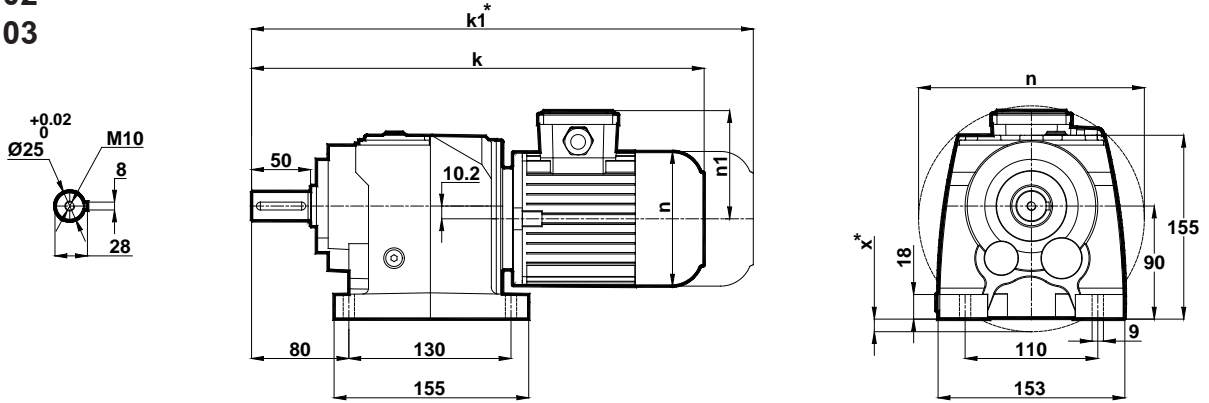

NR102
NR103

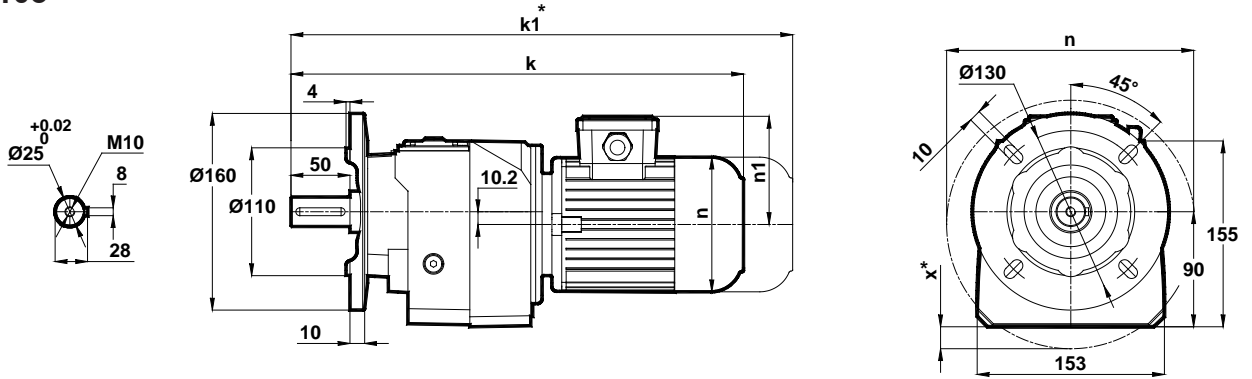

Motor Büyüklüğü / Motor Size / Motorbaugroße					
	63	71	80	90S	90L
k	394	413	442	471	508
k1	447	533	562	596	633
n	121	138	156	176	176
n1	97	111	118	126	126
x	-	-	-	10	10

Klemens Kutusu / Terminal Box / Klemmenkasten

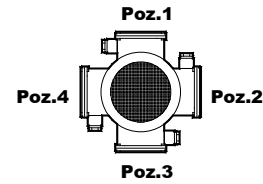

63-71-80-90

Opsiyonel Flanş Ölçüleri / Optional Flange Dimensions / Auswählbare Flanschabmessungen

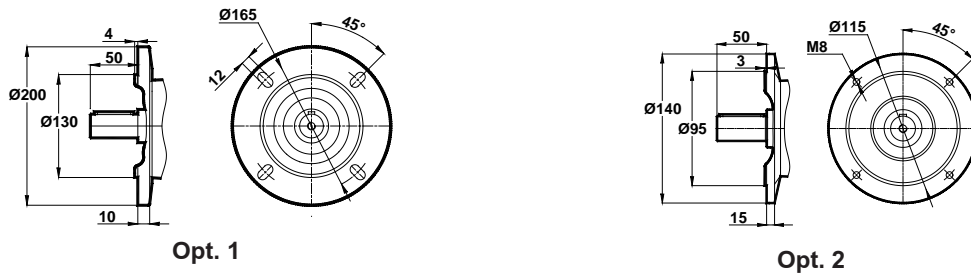

* "k1" Ölçüsü frenli redüktörlere aittir. Dimension "k1" is for motors with brake. Maße "k1" ist für Bremsenmotoren.

x: Motor, ayak bağlantı yüzeyinin altında ise / x: If Motor is lower then foot mounting plane / x: Wenn motor ist niedriger den die Anschlussplatte

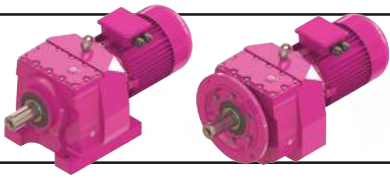

Ölçü Sayfaları Dimension Pages Abmessungsseiten



-Mil ucu çekirme deliği DIN 332 sayfa 2 / Tapped center hole to DIN 332, sheet 2 / Zentrierung mit gewinde DIN 332, Blatt 2

MR172 MR173

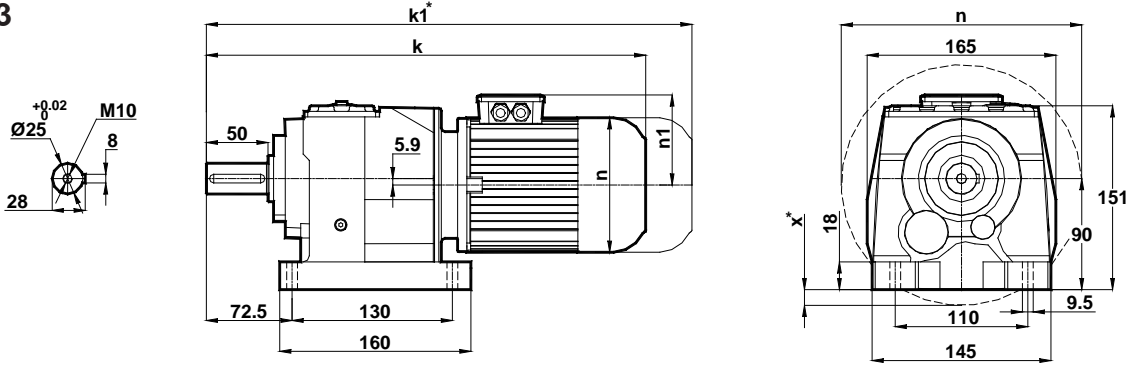

NR172 NR173

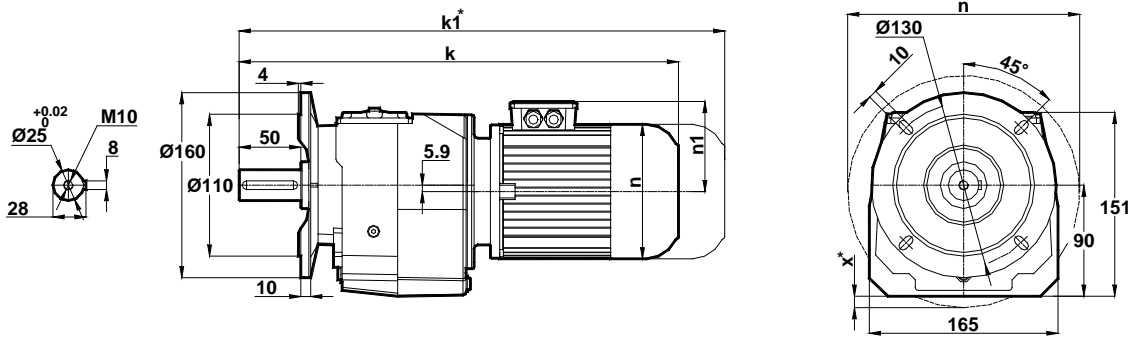

Motor Büyüklüğü / Motor Size / Motorbaugroße							
	63	71	80	90S	90L	100L	112M
k	395	414	442	470	510	536	559
k1	448	534	562	595	635	671	694
n	121	138	156	176	176	194	218
n1	97	111	118	126	126	135	146
x	-	-	-	6	6	16	28

Klemens Kutusu / Terminal Box / Klemmenkasten

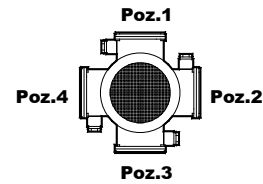

63-71-80-90-100-112

Opsiyonel Flanş Ölçüleri / Optional Flange Dimensions / Auswählbare Flanschabmessungen

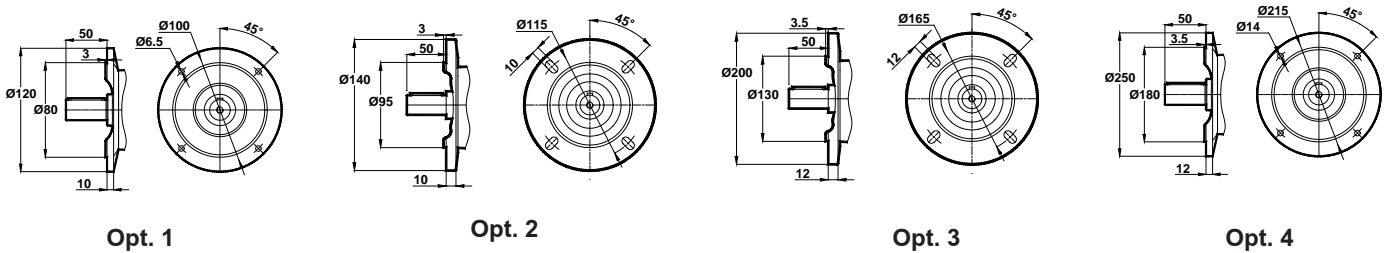

* " k1 " Ölçüsü frenli redüktörlere aittir. Dimension " k1 " is for motors with brake. Maße " k1 " ist für Bremsenmotoren.

x: Motor, ayak bağlantı yüzeyinin altında ise / x: If Motor is lower then foot mounting plane / x: Wenn motor ist niedriger den die Anschlußplatte

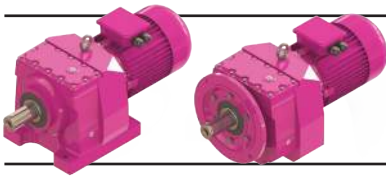

Ölçü Sayfaları Dimension Pages Abmessungsseiten



-Mil ucu çektirme deliği DIN 332 sayfa 2 / Tapped center hole to DIN 332, sheet 2 / Zentrierung mit gewinde DIN 332, Blatt 2

MR202
MR203

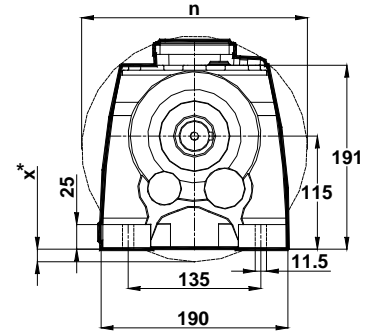
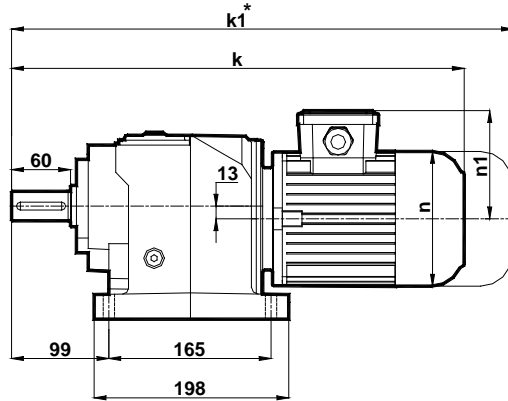
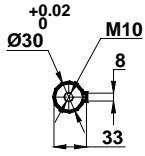

NR202
NR203

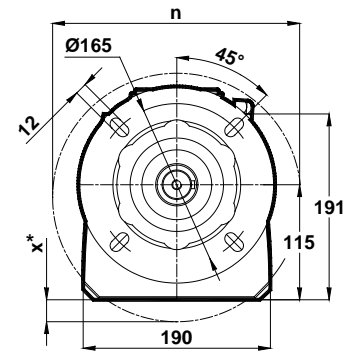
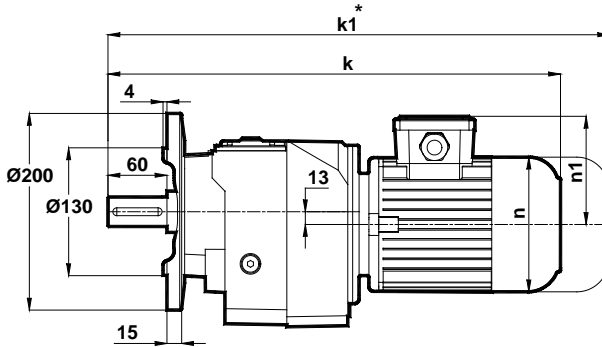
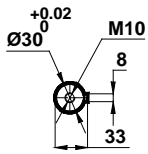

Motor Büyüklüğü / Motor Size / Motorbaugroße							
	63	71	80	90S	90L	100L	112M
k	442	461	489	517	542	583	606
k1	495	581	609	642	667	718	741
n	121	138	156	176	176	194	218
n1	97	111	118	126	126	135	146
x	-	-	-	-	-	-	10

Klemens Kutusu / Terminal Box / Klemmenkasten

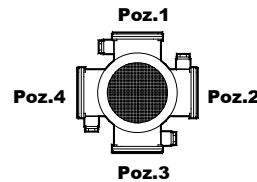

63-80-90-100-112

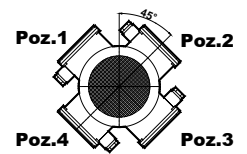

71

Opsiyonel Flanş Ölçüleri / Optional Flange Dimensions / Auswählbare Flanschabmessungen

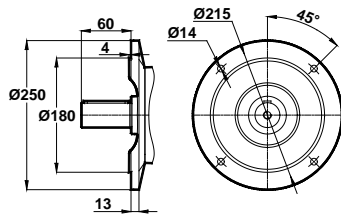

Opt. 1

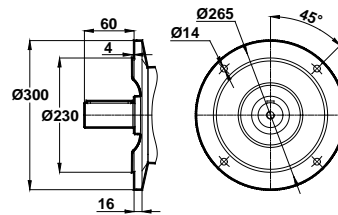

Opt. 2

* " k1 " Ölçüsü frenli redüktörlere aittir. Dimension " k1 " is for motors with brake. Maße " k1 " ist für Bremsenmotoren.

x: Motor, ayak bağlantı yüzeyinin altında ise / x: If Motor is lower then foot mounting plane / x: Wenn motor ist niedriger den die Anschlussplatte

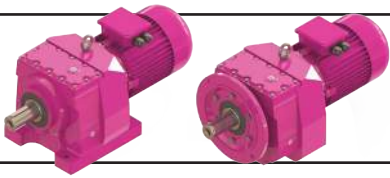

Ölçü Sayfaları Dimension Pages Abmessungsseiten



-Mil ucu çektirme deliği DIN 332 sayfa 2 / Tapped center hole to DIN 332, sheet 2 / Zentrierung mit gewinde DIN 332, Blatt 2

MR272 MR273

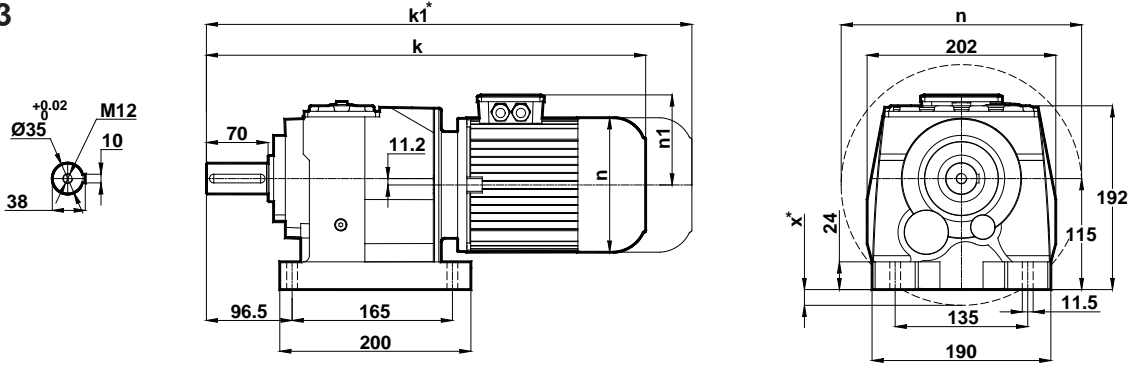

NR272 NR273

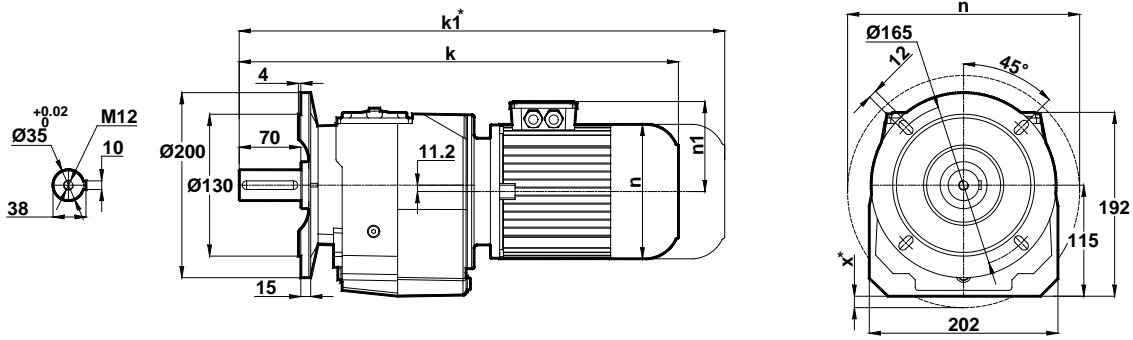

Motor Büyüklüğü / Motor Size / Motorbaugroße							
	63	71	80	90S	90L	100L	112M
k	443	462	490	518	543	584	607
k1	496	582	610	643	668	719	742
n	121	138	156	176	176	194	218
n1	97	111	118	126	126	135	146
x	-	-	-	-	-	-	9

Klemens Kutusu / Terminal Box / Klemmenkasten

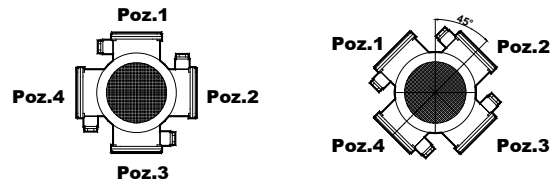

63-80-90-100-112

71

Opsiyonel Flanş Ölçüleri / Optional Flange Dimensions / Auswählbare Flanschabmessungen

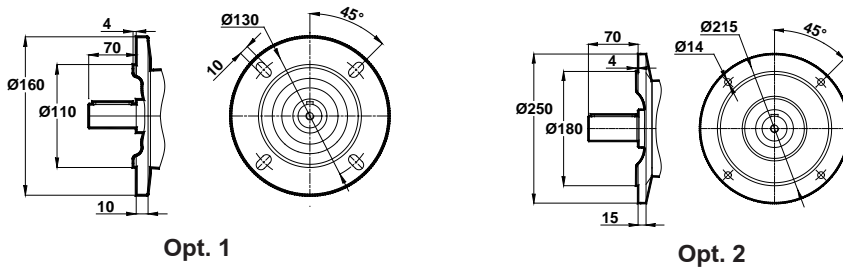

* " k1 " Ölçüsü frenli redüktörlere aittir. Dimension " k1 " is for motors with brake. Maße " k1 " ist für Bremsenmotoren.

x: Motor, ayak bağlantı yüzeyinin altında ise / x: If Motor is lower then foot mounting plane / x: Wenn motor ist niedriger den die Anschlußplatte

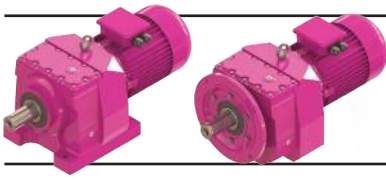

Ölçü Sayfaları Dimension Pages Abmessungsseiten



-Mil ucu çektirme deliği DIN 332 sayfa 2 / Tapped center hole to DIN 332, sheet 2 / Zentrierung mit gewinde DIN 332, Blatt 2

MR275 MR276

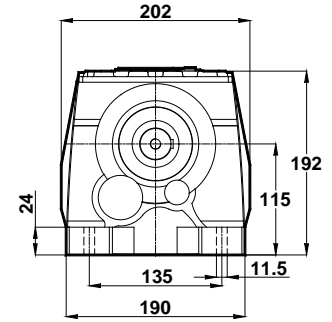
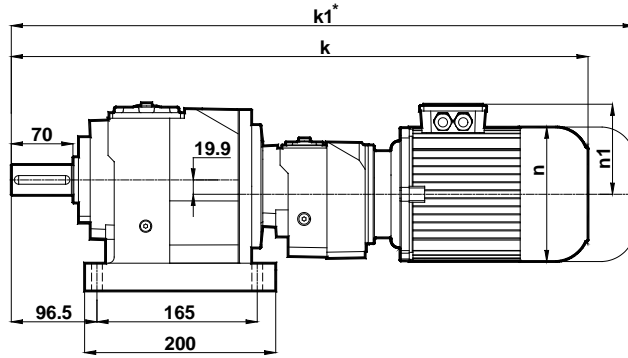
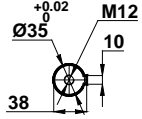

NR275 NR276

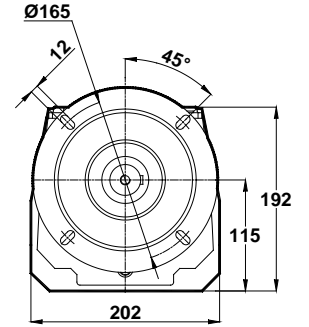
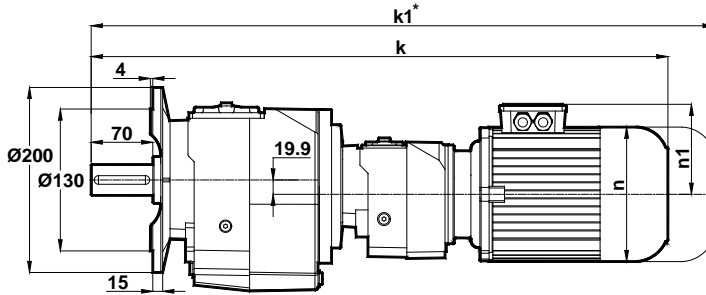
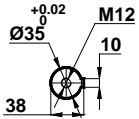

Motor Büyüklüğü / Motor Size / Motorbaugroße	63	71
k	593	614
k1	646	734
n	121	138
n1	97	111

Klemens Kutusu / Terminal Box / Klemmenkasten

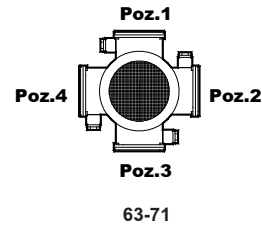

Opsiyonel Flanş Ölçüleri / Optional Flange Dimensions / Auswählbare Flanschabmessungen

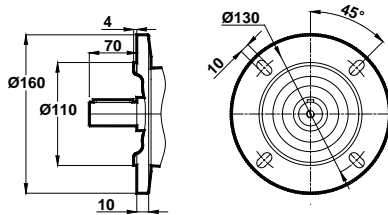

Opt. 1

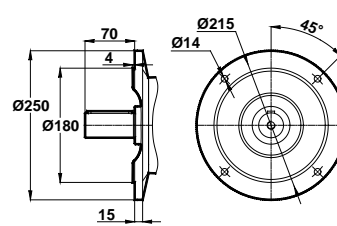

Opt. 2

* " k1 " Ölçüsü frenli redüktörlere aittir. Dimension " k1 " is for motors with brake. Maße " k1 " ist für Bremsenmotoren.



Ölçü Sayfaları Dimension Pages Abmessungsseiten



-Mil ucu çekirme deliği DIN 332 sayfa 2 / Tapped center hole to DIN 332, sheet 2 / Zentrierung mit gewinde DIN 332, Blatt 2

MR282 MR283

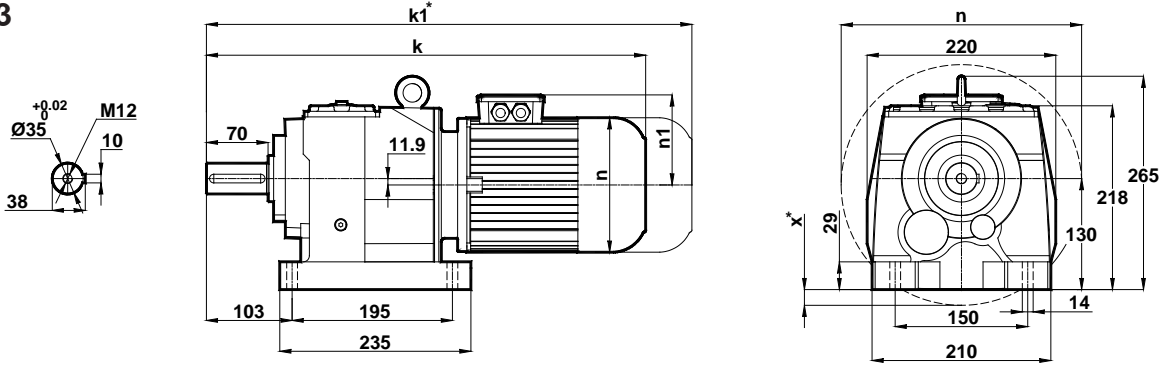

NR282 NR283

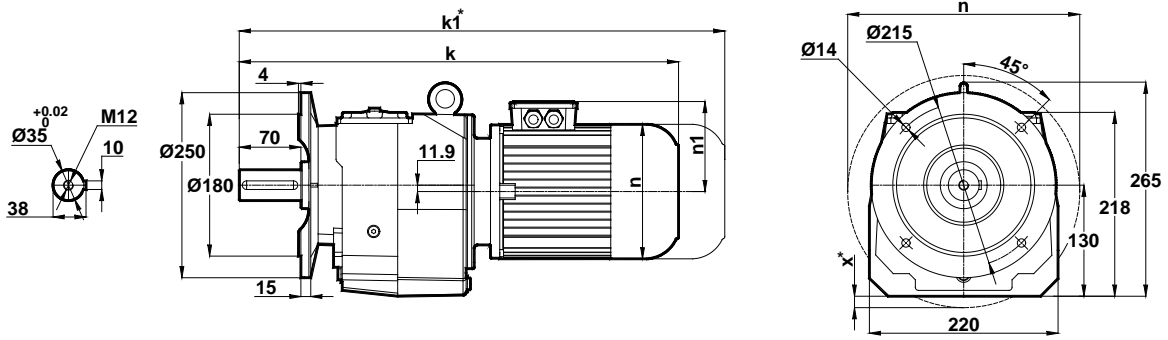

Motor Büyüklüğü / Motor Size / Motorbaugroße								
	71	80	90S	90L	100L	112M	132S	132M
k	479	507	537	562	602	625	679	717
k1	599	627	662	687	737	760	824	862
n	138	156	176	176	194	218	257	257
n1	111	118	126	126	135	146	168	168
x	-	-	-	-	-	-	-	14

Klemens Kutusu / Terminal Box / Klemmenkasten

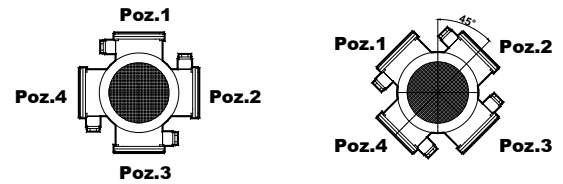

71-100-112-132

80-90

Opsiyonel Flanş Ölçüleri / Optional Flange Dimensions / Auswählbare Flanschabmessungen

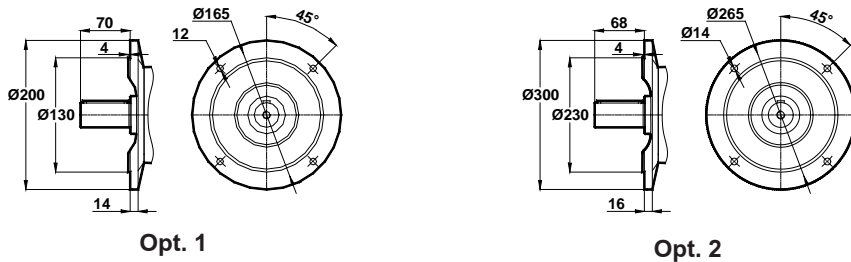

* " k1 " Ölçüsü frenli redüktörlere aittir. Dimension " k1 " is for motors with brake. Maße " k1 " ist für Bremsenmotoren.

x: Motor, ayak bağlantı yüzeyinin altında ise / x: If Motor is lower then foot mounting plane / x: Wenn motor ist niedriger den die Anschlußplatte

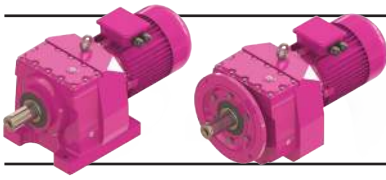

Ölçü Sayfaları Dimension Pages Abmessungsseiten



-Mil ucu çektirme deliği DIN 332 sayfa 2 / Tapped center hole to DIN 332, sheet 2 / Zentrierung mit gewinde DIN 332, Blatt 2

MR284

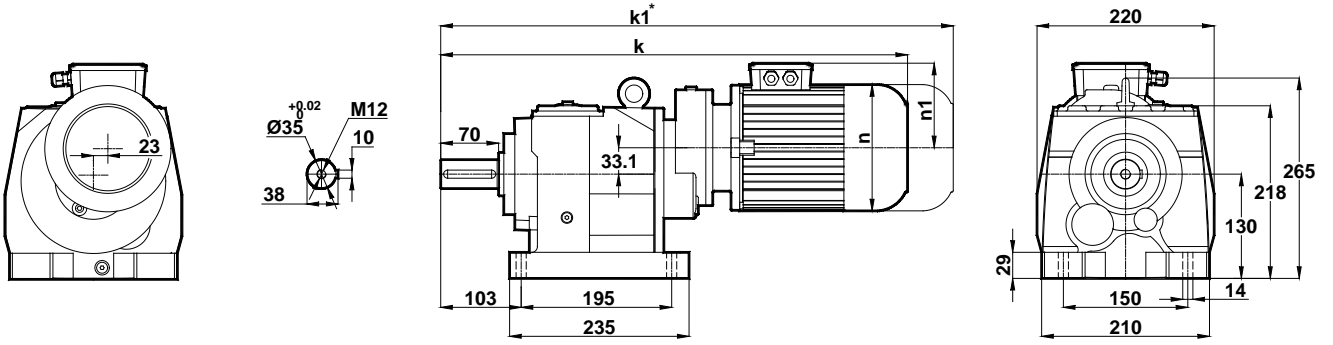

NR284

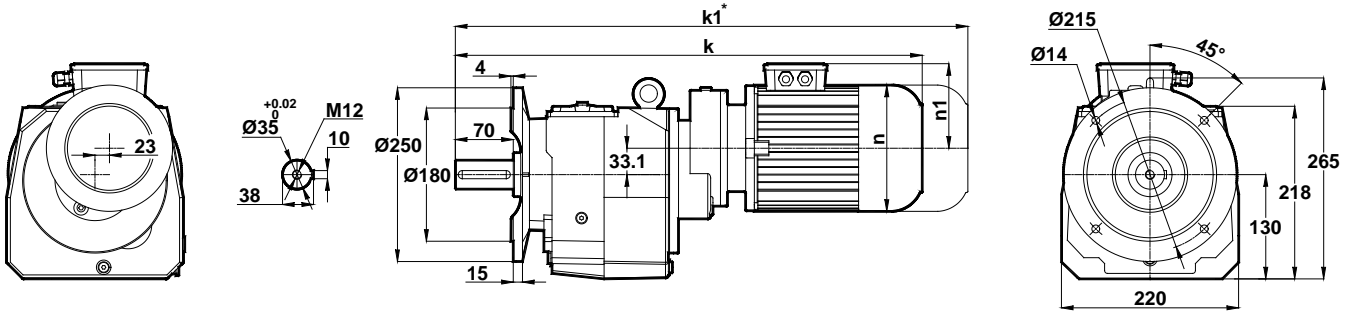

Motor Büyüklüğü / Motor Size / Motorbaugroße	63	71
k	540	558
k1	593	678
n	121	138
n1	97	111

Klemens Kutusu / Terminal Box / Klemmenkasten

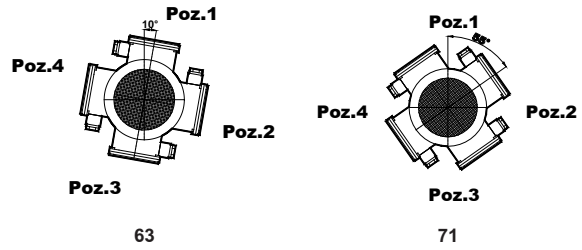

Opsiyonel Flanş Ölçüleri / Optional Flange Dimensions / Auswählbare Flanschabmessungen

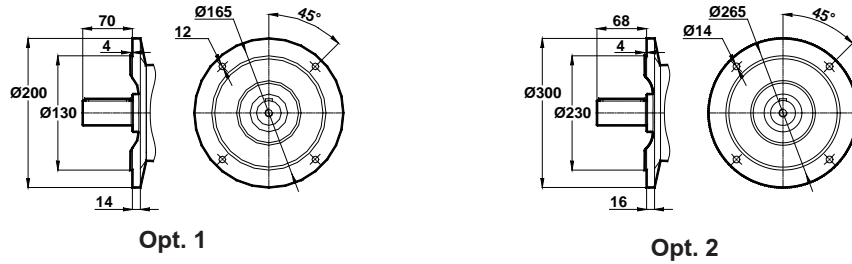

* "k1" ölçüsü frenli redüktörlere aittir. Dimension "k1" is for motors with brake. Maße "k1" ist für Bremsenmotoren.

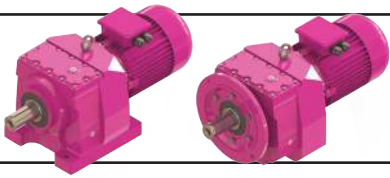

Ölçü Sayfaları Dimension Pages Abmessungenseiten



-Mil ucu çekirme deliği DIN 332 sayfa 2 / Tapped center hole to DIN 332, sheet 2 / Zentrierung mit gewinde DIN 332, Blatt 2

MR285 MR286

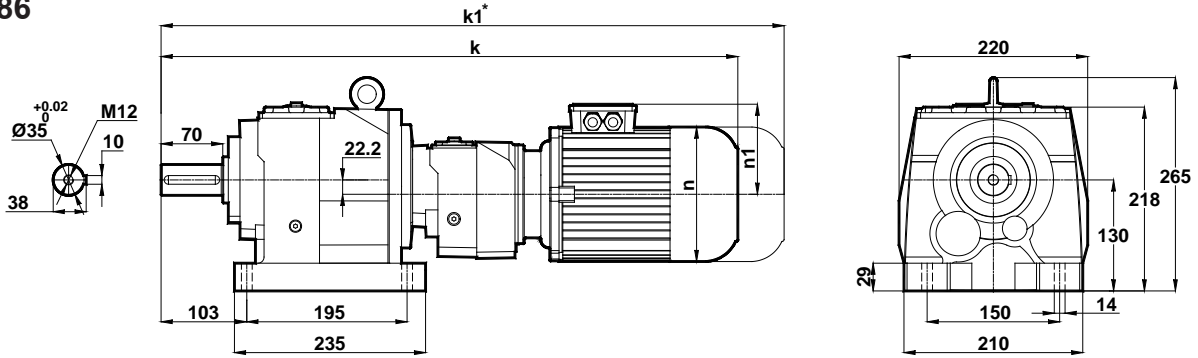

NR285 NR286

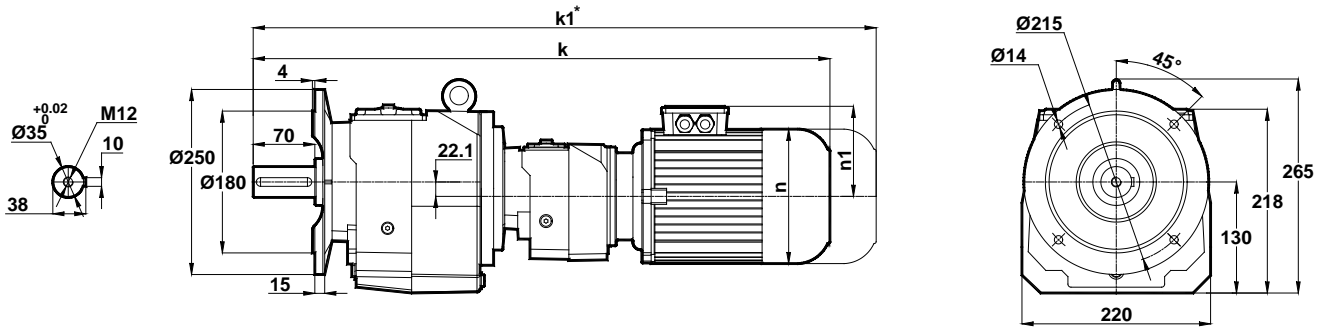

Motor Büyüklüğü / Motor Size / Motorbaugroße	
	63
k	641
k1	694
n	121
n1	97

Klemens Kutusu / Terminal Box / Klemmenkasten

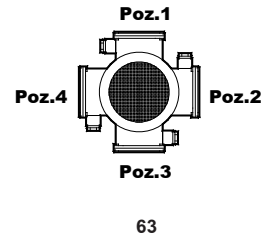

Opsiyonel Flanş Ölçüleri / Optional Flange Dimensions / Auswählbare Flanschabmessungen

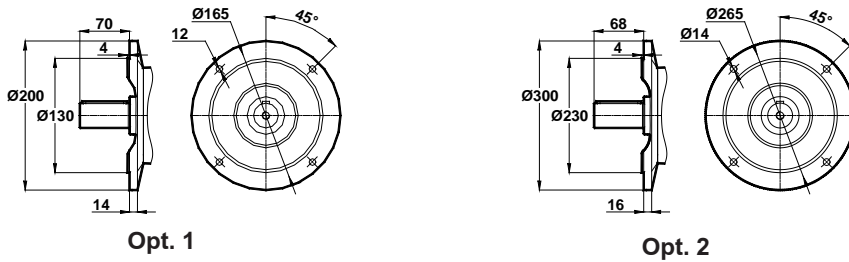

* " k1 " Ölçüsü frenli redüktörlere aittir. Dimension " k1 " is for motors with brake. Maße " k1 " ist für Bremsenmotoren.

x: Motor, ayak bağlantı yüzeyinin altında ise / x: If Motor is lower then foot mounting plane / x: Wenn motor ist niedriger den die Anschlußplatte

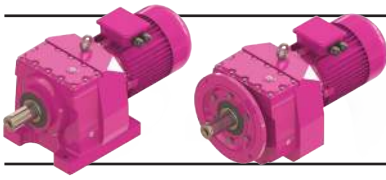

Ölçü Sayfaları Dimension Pages Abmessungenseiten



-Mil ucu çektirme deliği DIN 332 sayfa 2 / Tapped center hole to DIN 332, sheet 2 / Zentrierung mit gewinde DIN 332, Blatt 2

MR372 MR373

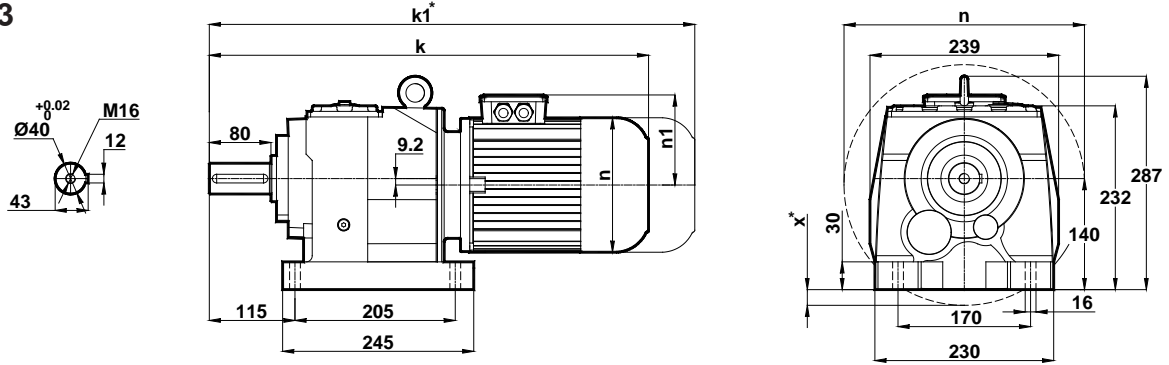

NR372 NR373

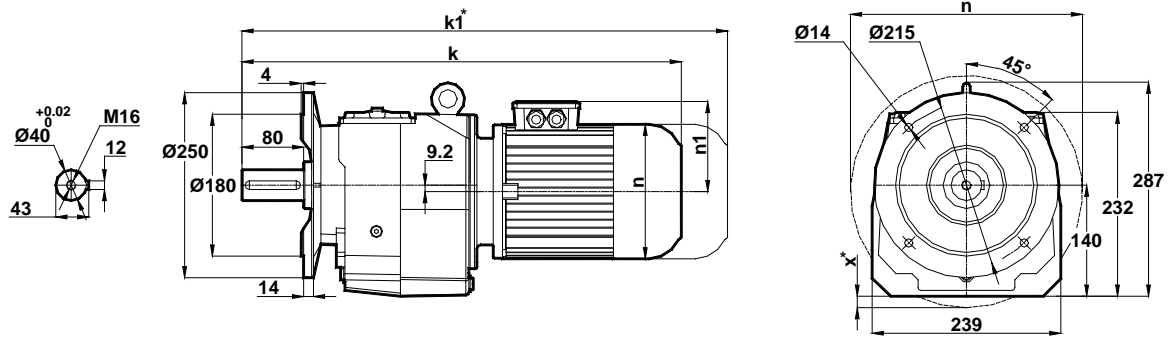

Motor Büyüklüğü / Motor Size / Motorbaugroße								
	71	80	90S	90L	100L	112M	132S	132M
k	500	528	558	583	623	646	700	738
k1	620	648	683	708	758	781	845	883
n	138	156	176	176	194	218	257	257
n1	111	118	126	126	135	146	168	168
x	-	-	-	-	-	-	2	30

Klemens Kutusu / Terminal Box / Klemmenkasten

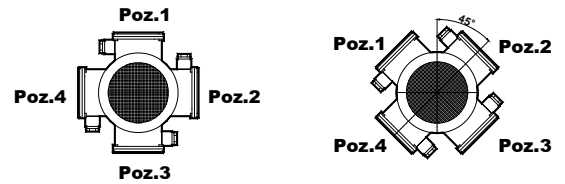

71-100-112-132

80-90

Opsiyonel Flanş Ölçüleri / Optional Flange Dimensions / Auswählbare Flanschabmessungen

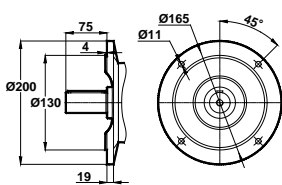

Opt. 1

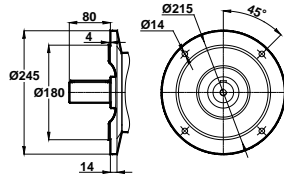

Opt. 2

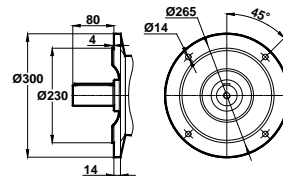

Opt. 3

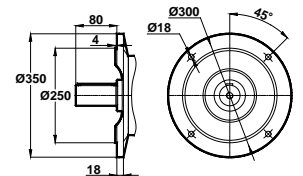

Opt. 4

* " k1 " Ölçüsü frenli redüktörlere aittir. Dimension " k1 " is for motors with brake. Maße " k1 " ist für Bremsenmotoren.

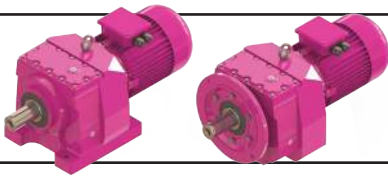

Ölçü Sayfaları

Dimension Pages

Abmessungsseiten



-Mil ucu çektirme deliği DIN 332 sayfa 2 / Tapped center hole to DIN 332, sheet 2 / Zentrierung mit gewinde DIN 332, Blatt 2

MR374

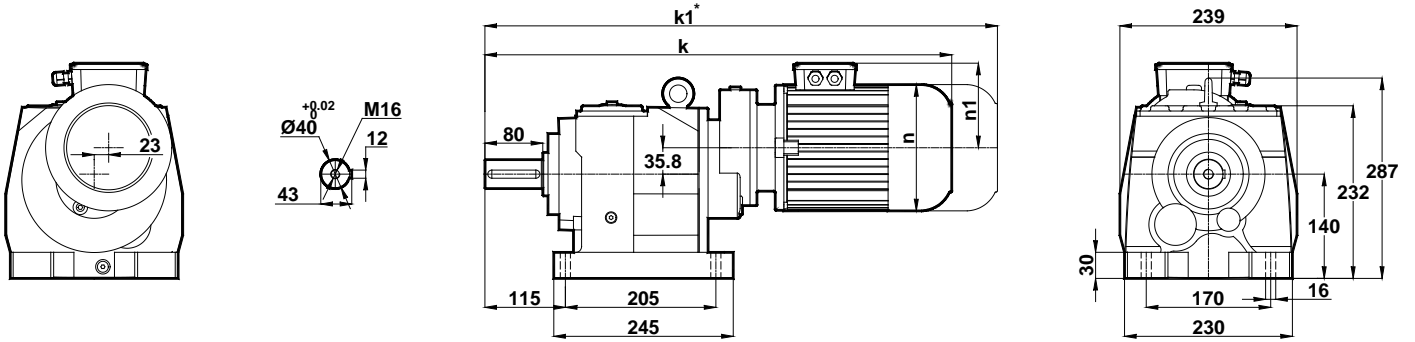

NR374

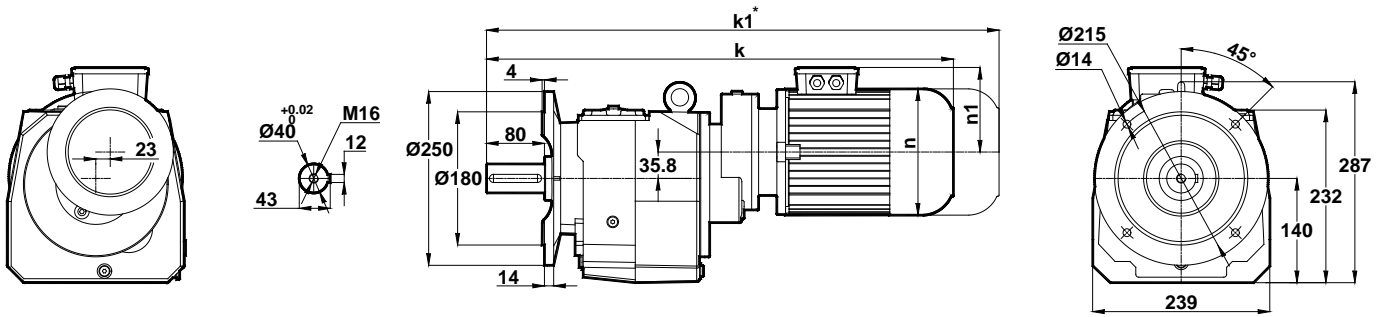

Motor Büyüklüğü / Motor Size / Motorbaugroße	63	71	80
k	561	579	608
k1	614	699	728
n	121	138	156
n1	97	111	118

Klemens Kutusu / Terminal Box / Klemmenkasten

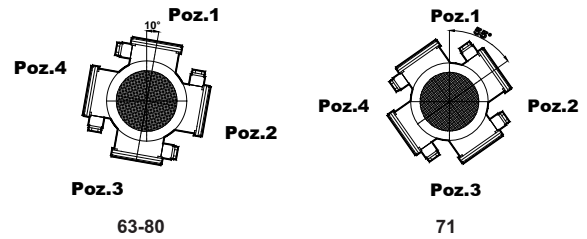

Opsiyonel Flanş Ölçüleri / Optional Flange Dimensions / Auswählbare Flanschabmessungen

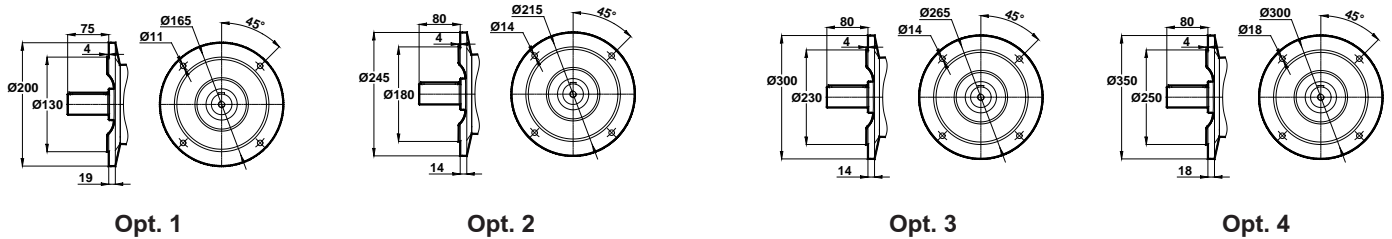

* " k1 " Ölçüsü frenli redüktörlere aittir. Dimension " k1 " is for motors with brake. Maße " k1 " ist für Bremsenmotoren.

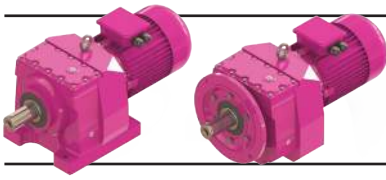

Ölçü Sayfaları Dimension Pages Abmessungsseiten



-Mil ucu çektirme deliği DIN 332 sayfa 2 / Tapped center hole to DIN 332, sheet 2 / Zentrierung mit gewinde DIN 332, Blatt 2

MR375 MR376

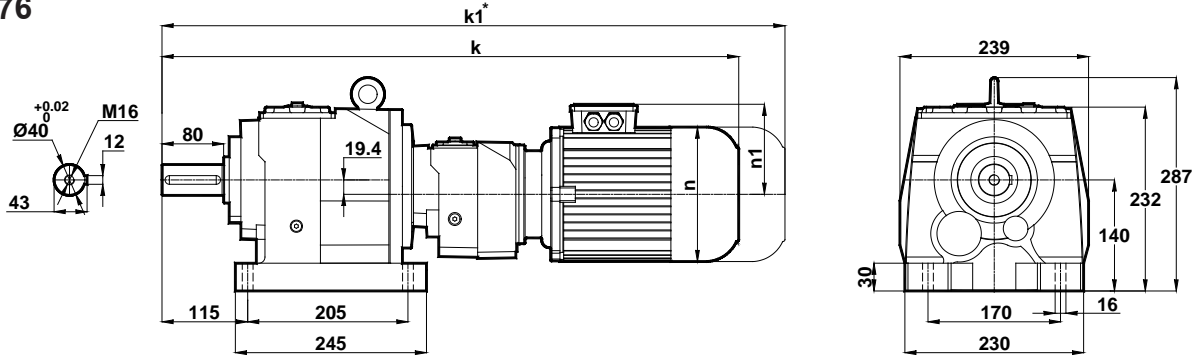

NR375 NR376

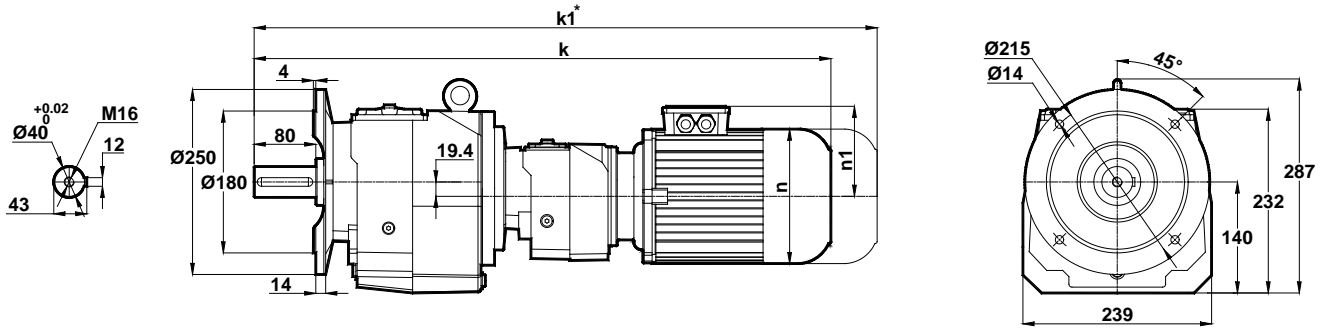

Motor Büyüklüğü / Motor Size / Motorbaugroße	
	63
k	662
k1	715
n	121
n1	97

Klemens Kutusu / Terminal Box / Klemmenkasten

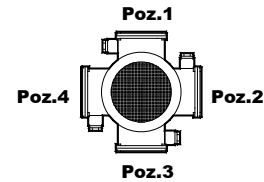

63

Opsiyonel Flanş Ölçüleri / Optional Flange Dimensions / Auswählbare Flanschabmessungen

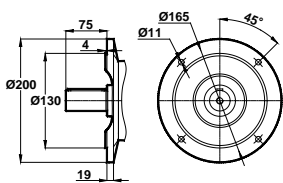

Opt. 1

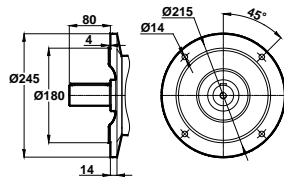

Opt. 2

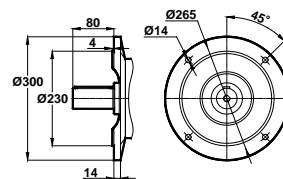

Opt. 3

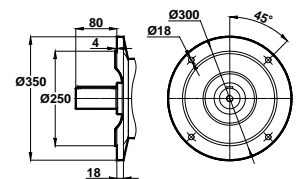

Opt. 4

* " k1 " Ölçüsü frenli redüktörlere aittir. Dimension " k1 " is for motors with brake. Maße " k1 " ist für Bremsenmotoren.

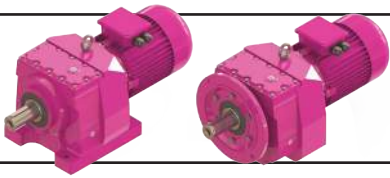

Ölçü Sayfaları Dimension Pages Abmessungsseiten



-Mil ucu çektirme deliği DIN 332 sayfa 2 / Tapped center hole to DIN 332, sheet 2 / Zentrierung mit gewinde DIN 332, Blatt 2

MR472 MR473

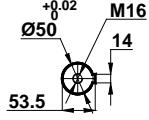
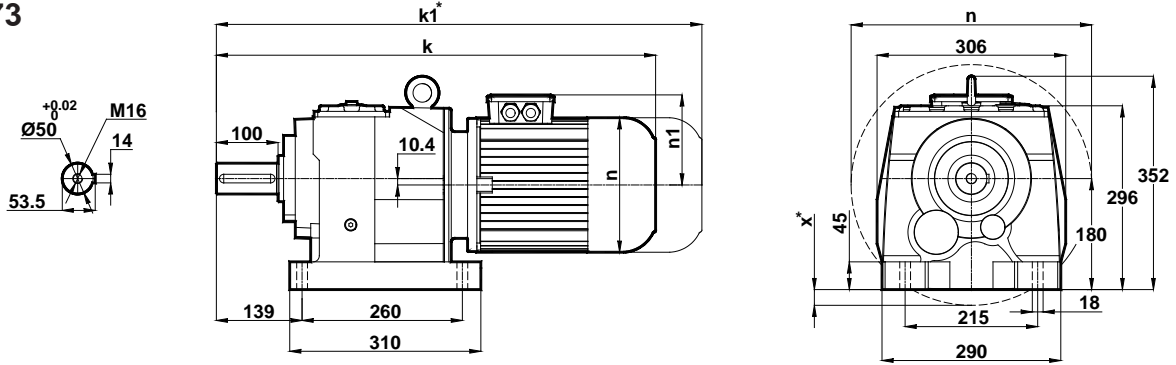

NR472 NR473

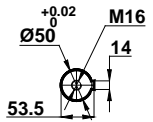
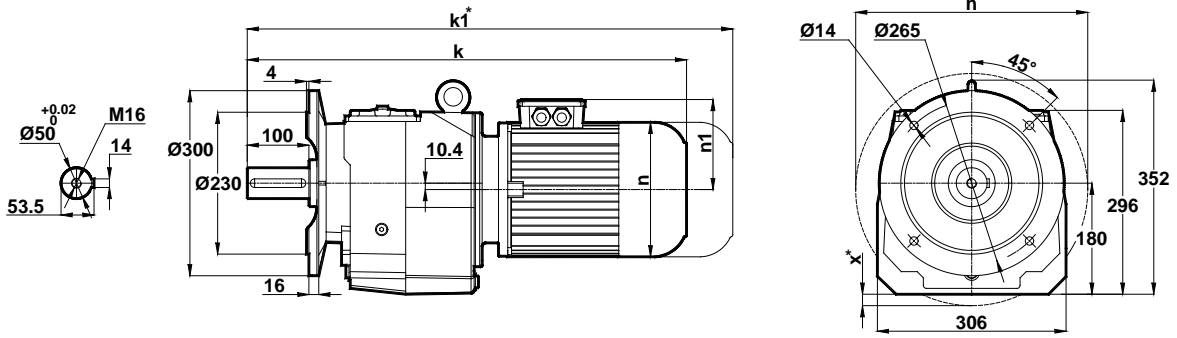

Motor Büyüklüğü / Motor Size / Motorbaugroße											
	80	90S	90L	100L	112M	132S	132M	160M	160L	180M	180L
k	596	624	649	688	713	762	800	875	919	936	974
k1	716	749	774	823	848	907	945	1045	1089	1106	1144
n	156	176	176	194	218	257	257	310	310	348	348
n1	118	126	126	135	146	168	168	225	225	241	241
x	-	-	-	-	-	-	-	-	-	11	11

Klemens Kutusu / Terminal Box / Klemmenkasten

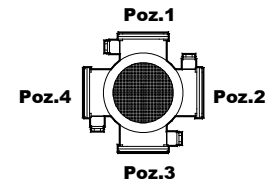

80-90-100-112-132-160-180

Opsiyonel Flanş Ölçüleri / Optional Flange Dimensions / Auswählbare Flanschabmessungen

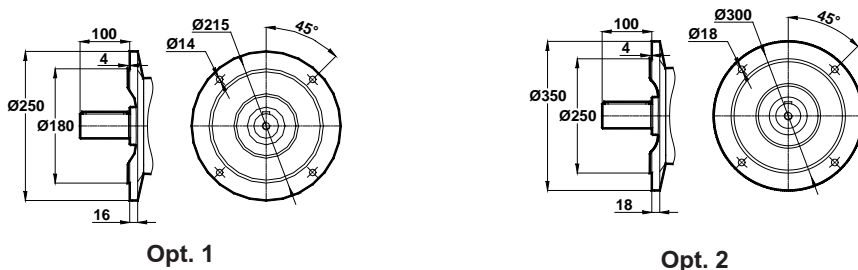

* "k1" Ölçüsü frenli redüktörlere aittir. Dimension "k1" is for motors with brake. Maße "k1" ist für Bremsenmotoren.

x: Motor, ayak bağlantı yüzeyinin altında ise / x: If Motor is lower then foot mounting plane / x: Wenn motor ist niedriger den die Anschlussplatte

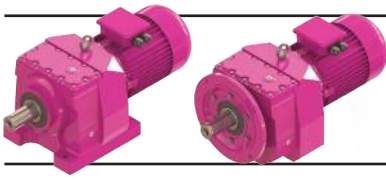

Ölçü Sayfaları Dimension Pages Abmessungsseiten



-Mil ucu çektirme deliği DIN 332 sayfa 2 / Tapped center hole to DIN 332, sheet 2 / Zentrierung mit gewinde DIN 332, Blatt 2

MR474

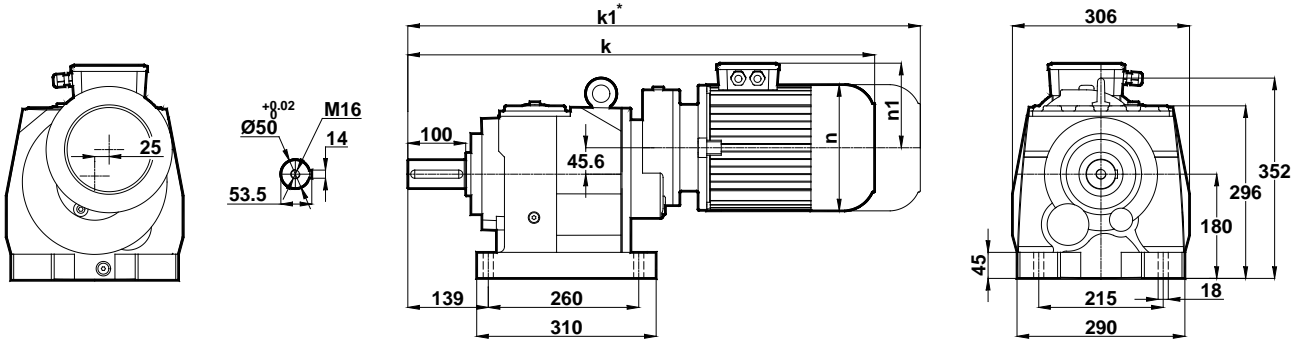

NR474

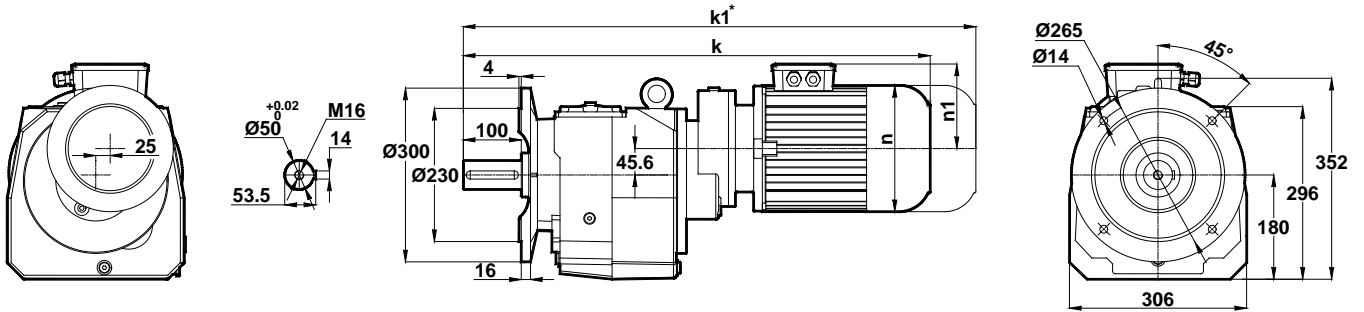

Motor Büyüklüğü / Motor Size / Motorbaugroße		
	71	80
k	661	689
k1	781	809
n	138	156
n1	111	118

Klemens Kutusu / Terminal Box / Klemmenkasten

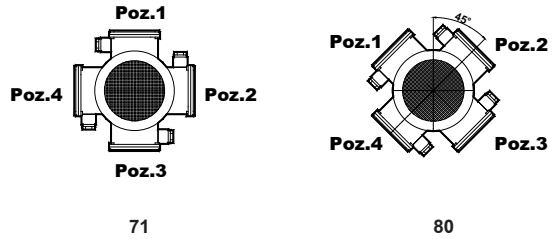

Opsiyonel Flanş Ölçüleri / Optional Flange Dimensions / Auswählbare Flanschabmessungen

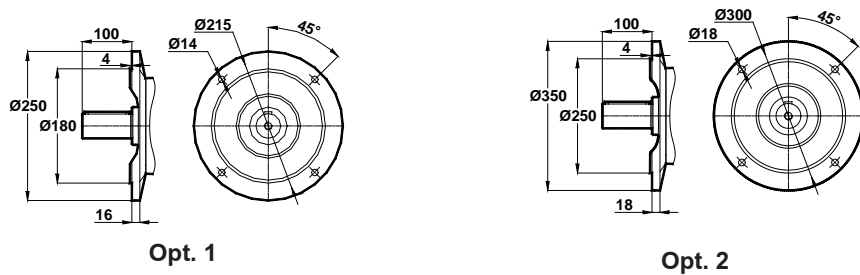

* "k1" Ölçüsü frenli redüktörlere aittir. Dimension "k1" is for motors with brake. Maße "k1" ist für Bremsenmotoren.



Ölçü Sayfaları Dimension Pages Abmessungsseiten



-Mil ucu çektirme deliği DIN 332 sayfa 2 / Tapped center hole to DIN 332, sheet 2 / Zentrierung mit gewinde DIN 332, Blatt 2

MR475 MR476

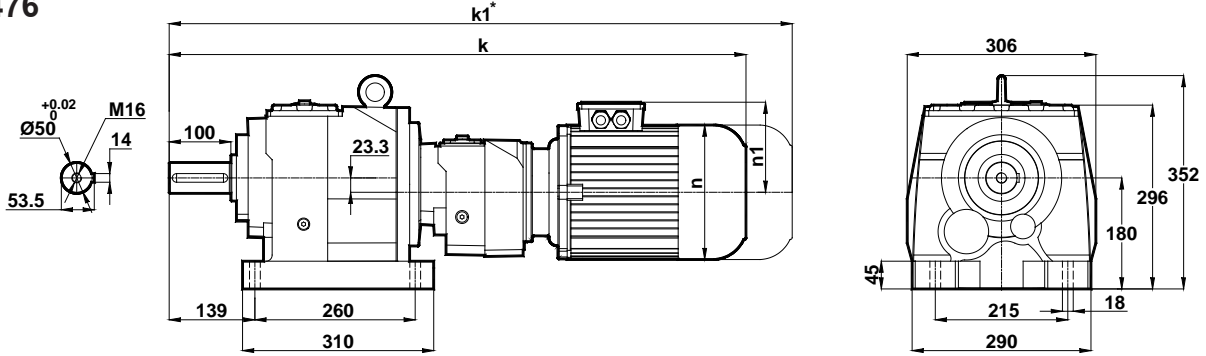

NR475 NR476

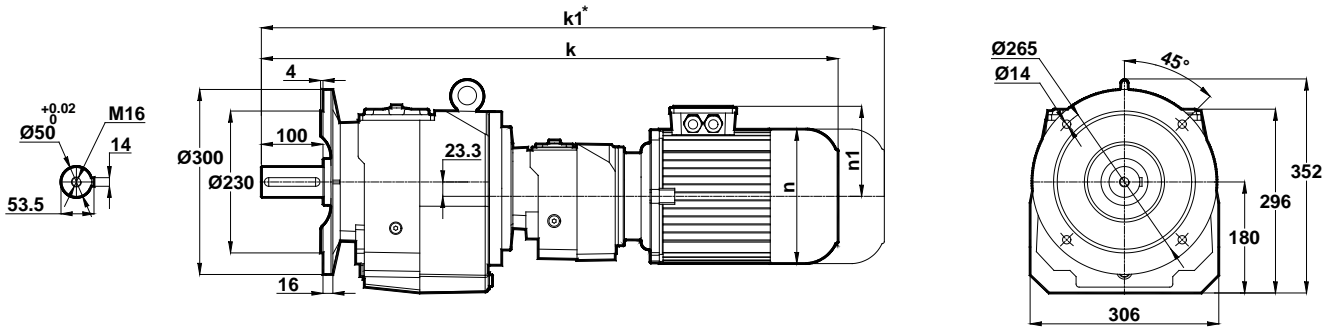

Motor Büyüklüğü / Motor Size / Motorbaugroße	63	71
k	772	791
k1	825	911
n	121	138
n1	97	111

Klemens Kutusu / Terminal Box / Klemmenkasten

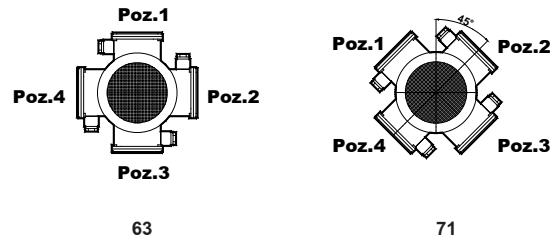

Opsiyonel Flanş Ölçüleri / Optional Flange Dimensions / Auswählbare Flanschabmessungen

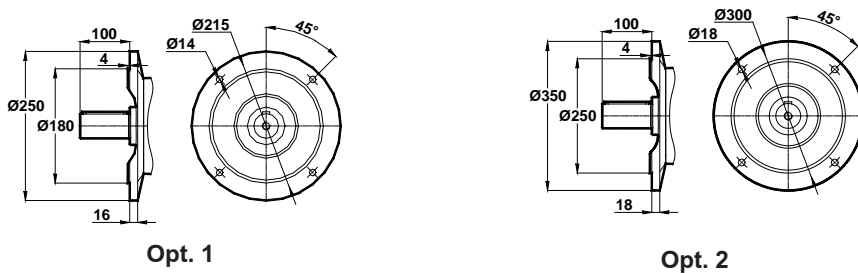

* " k1 " Ölçüsü frenli redüktörlere aittir. Dimension " k1 " is for motors with brake. Maße " k1 " ist für Bremsenmotoren.

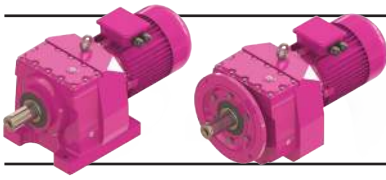

Ölçü Sayfaları Dimension Pages Abmessungsseiten



-Mil ucu çektirme deliği DIN 332 sayfa 2 / Tapped center hole to DIN 332, sheet 2 / Zentrierung mit gewinde DIN 332, Blatt 2

MR572 MR573

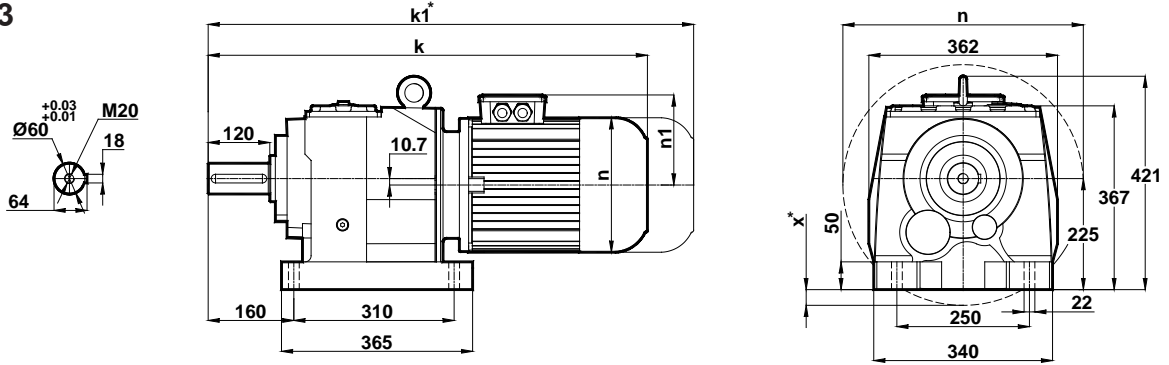

NR572 NR573

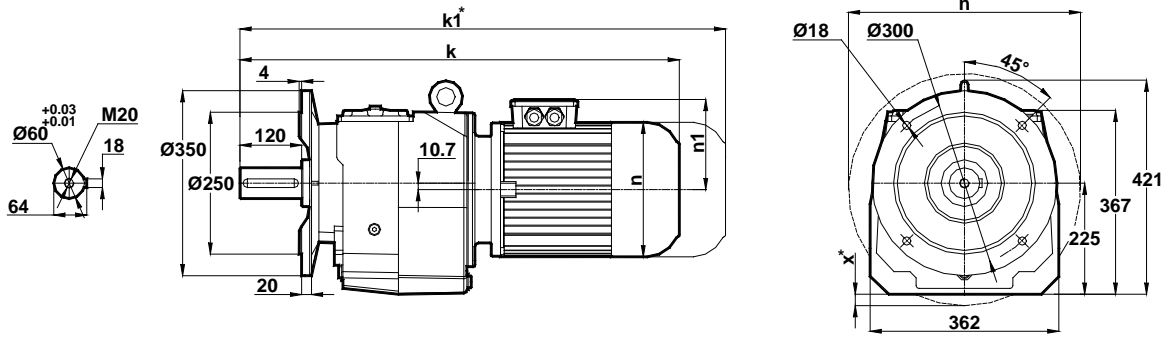

Motor Büyüklüğü / Motor Size / Motorbaugroße									
	100L	112M	132S	132M	160M	160L	180M	180L	200L
k	745	768	822	860	935	979	995	1033	1072
k1	880	903	967	1005	1105	1149	1165	1203	1272
n	194	218	257	257	310	310	348	348	390
n1	135	146	168	168	225	225	241	241	275
x	-	-	-	-	-	-	-	-	-

Klemens Kutusu / Terminal Box / Klemmenkasten

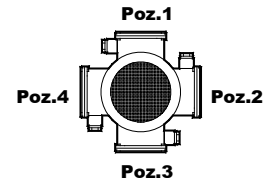

100-112-132-160-180-200

Opsiyonel Flanş Ölçüleri / Optional Flange Dimensions / Auswählbare Flanschabmessungen

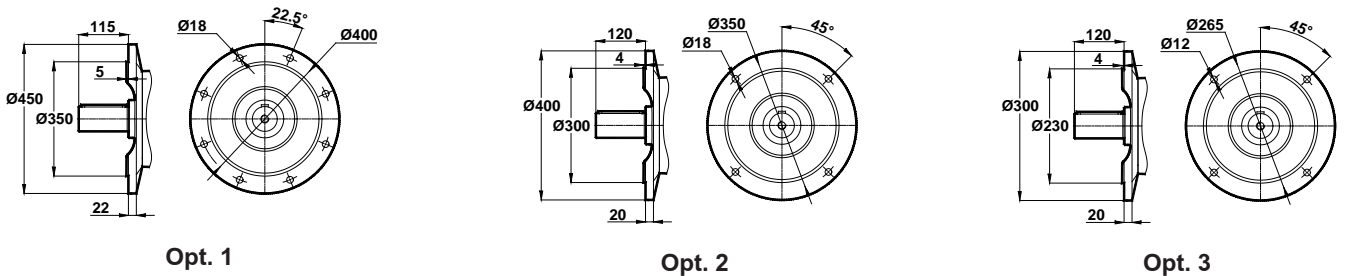

* "k1" ölçüsü frenli redüktörlere aittir. Dimension "k1" is for motors with brake. Maße "k1" ist für Bremsenmotoren.
x: Motor ayak bağlantı yüzeyinin altında ise / x: If Motor is lower then foot mounting plane / x: Wenn motor ist niedriger den die Anschlußplatte

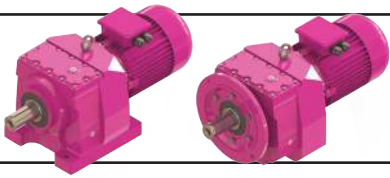

Ölçü Sayfaları Dimension Pages Abmessungsseiten



-Mil ucu çektirme deliği DIN 332 sayfa 2 / Tapped center hole to DIN 332, sheet 2 / Zentrierung mit gewinde DIN 332, Blatt 2

MR574

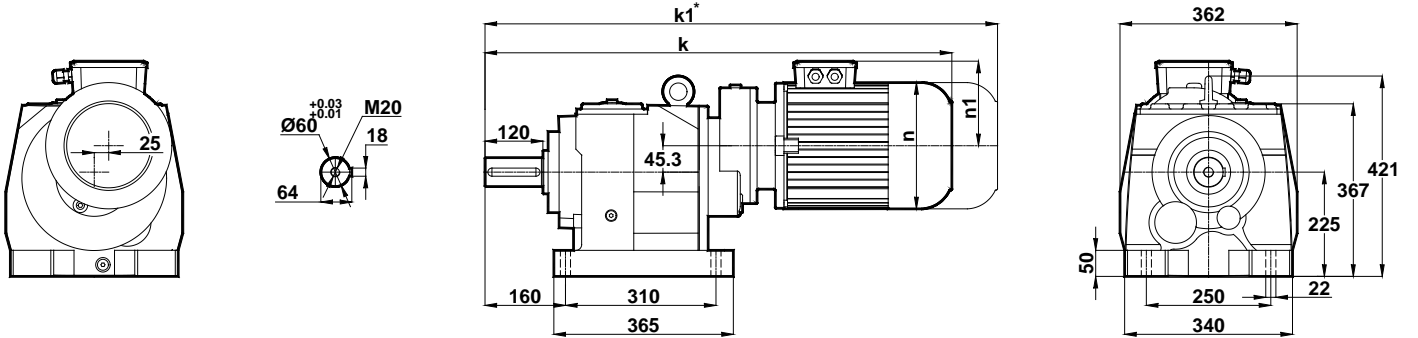

NR574

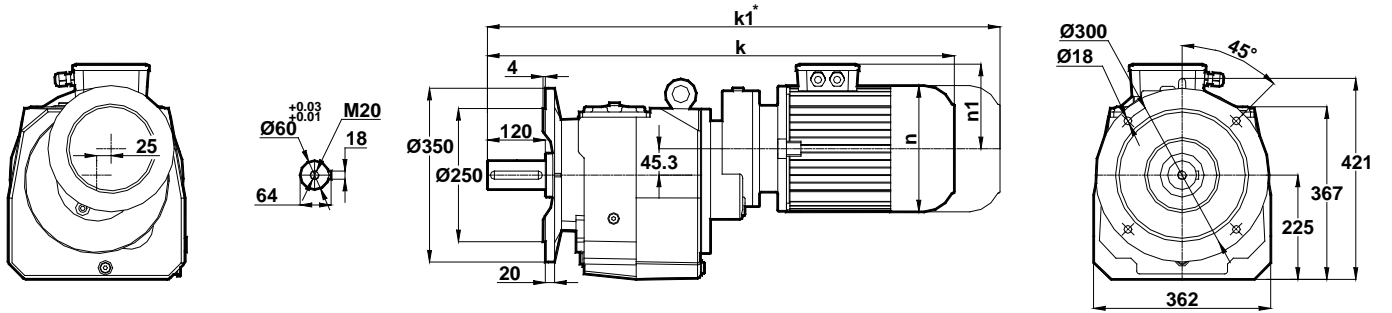

Motor Büyüklüğü / Motor Size / Motorbaugroße				
	71	80	90S	90L
k	723	751	780	805
k1	843	871	905	930
n	138	156	176	176
n1	111	118	126	126

Klemens Kutusu / Terminal Box / Klemmenkasten

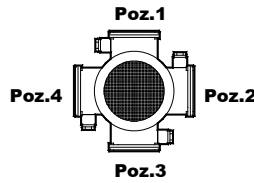

71

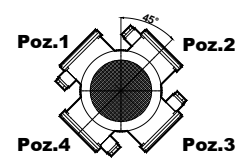

80-90

Opsiyonel Flanş Ölçüleri / Optional Flange Dimensions / Auswählbare Flanschabmessungen

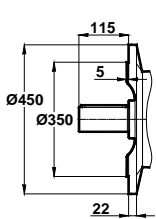

Opt. 1

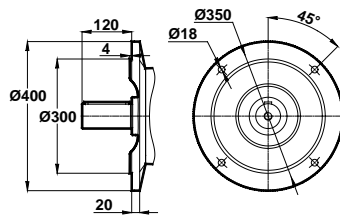

Opt. 2

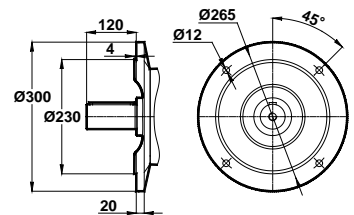

Opt. 3

* " k1 " Ölçüsü frenli redüktörlere aittir. Dimension " k1 " is for motors with brake. Maße " k1 " ist für Bremsenmotoren.

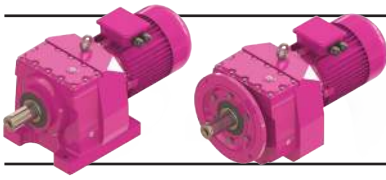

Ölçü Sayfaları Dimension Pages Abmessungsseiten



-Mil ucu çektirme deliği DIN 332 sayfa 2 / Tapped center hole to DIN 332, sheet 2 / Zentrierung mit gewinde DIN 332, Blatt 2

MR575 MR576

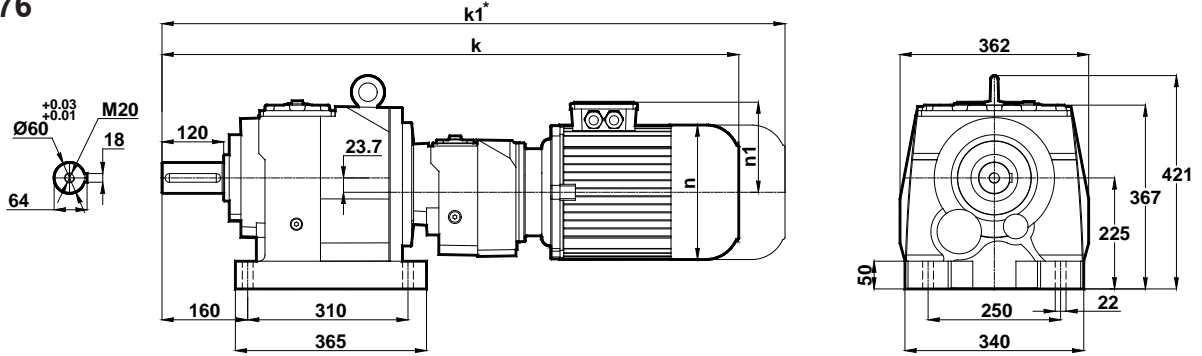

NR575 NR576

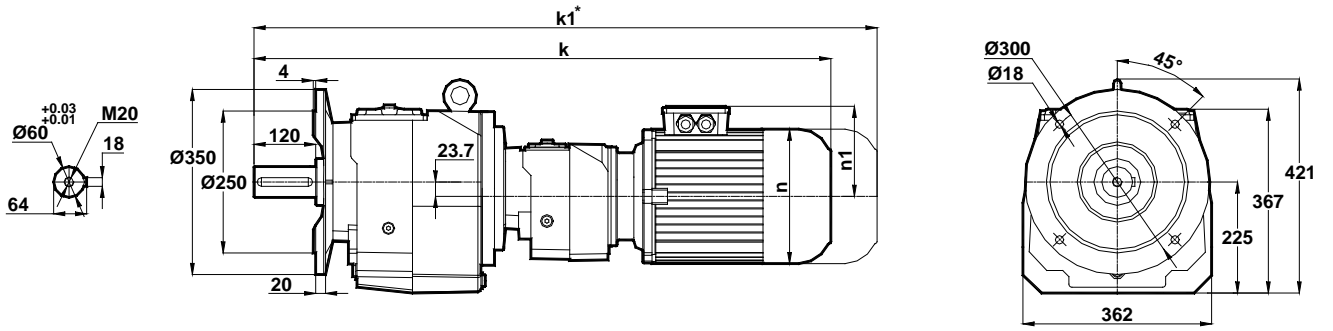

Motor Büyüklüğü / Motor Size / Motorbaugroße		
	63	71
k	836	855
k1	889	975
n	121	138
n1	97	111

Klemens Kutusu / Terminal Box / Klemmenkasten

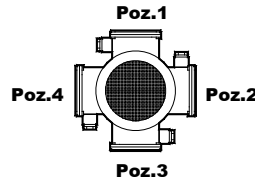

63

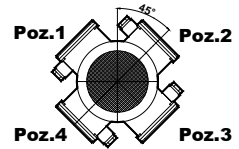

71

Opsiyonel Flanş Ölçüleri / Optional Flange Dimensions / Auswählbare Flanschabmessungen

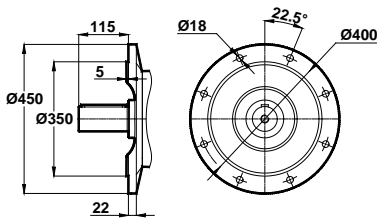

Opt. 1

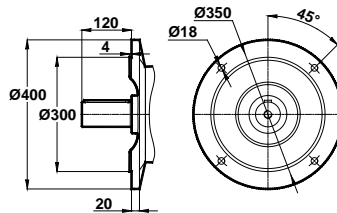

Opt. 2

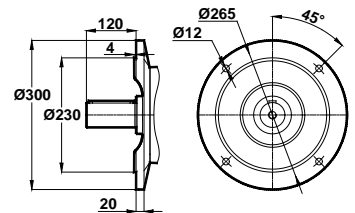

Opt. 3

* " k1 " Ölçüsü frenli redüktörlere aittir. Dimension " k1 " is for motors with brake. Maße " k1 " ist für Bremsenmotoren.

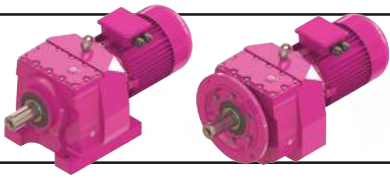

Ölçü Sayfaları Dimension Pages Abmessungsseiten



-Mil ucu çekirme deliği DIN 332 sayfa 2 / Tapped center hole to DIN 332, sheet 2 / Zentrierung mit gewinde DIN 332, Blatt 2

MR672 MR673

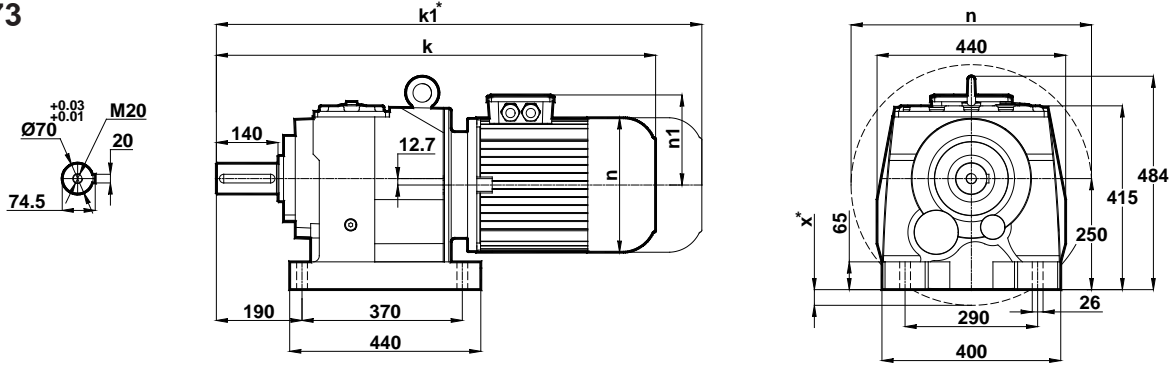

NR672 NR673

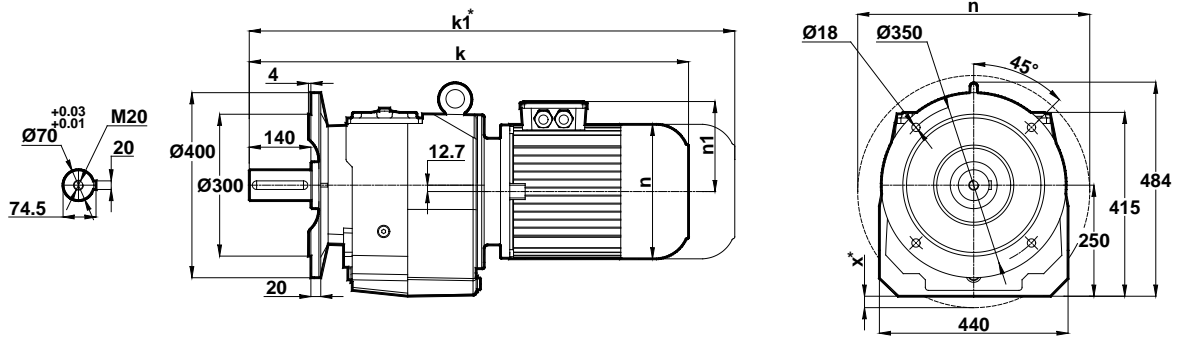

Motor Büyüklüğü / Motor Size / Motorbaugröße										
	112M	132S	132M	160M	160L	180M	180L	200L	225S	225M
k	825	879	917	991	1035	1049	1087	1129	1155	1180
k1	960	1024	1062	1161	1205	1219	1257	1329	1345	1370
n	218	257	257	310	310	348	348	390	434	434
n1	146	168	168	225	225	241	241	275	285	285
x	-	-	-	-	-	-	-	-	-	-

Klemens Kutusu / Terminal Box / Klemmenkasten

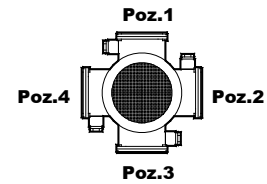

112-132-160-180-200-225

Opsiyonel Flanş Ölçüleri / Optional Flange Dimensions / Auswählbare Flanschabmessungen

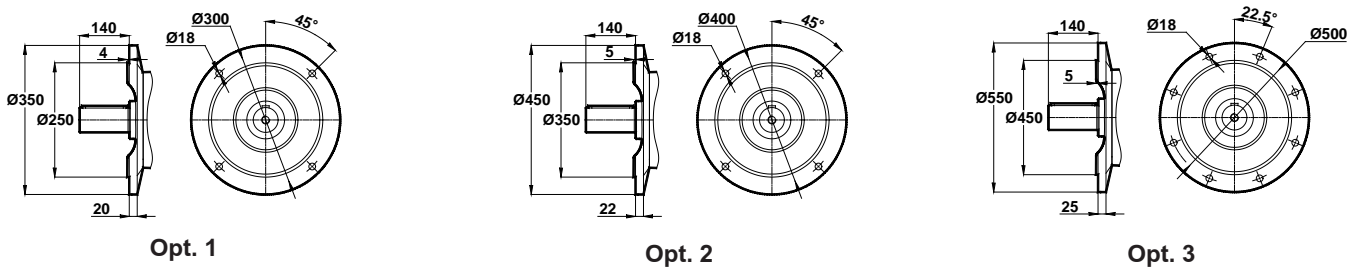

* " k1 " Ölçüsü frenli redüktörlere aittir. Dimension " k1 " is for motors with brake. Maße " k1 " ist für Bremsenmotoren.
x: Motor, ayak bağlantı yüzeyinin altında ise / x: If Motor is lower then foot mounting plane / x: Wenn motor ist niedriger den die Anschlussplatte

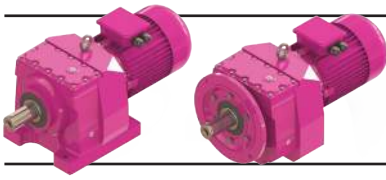

Ölçü Sayfaları Dimension Pages Abmessungsseiten



-Mil ucu çektirme deliği DIN 332 sayfa 2 / Tapped center hole to DIN 332, sheet 2 / Zentrierung mit gewinde DIN 332, Blatt 2

MR674

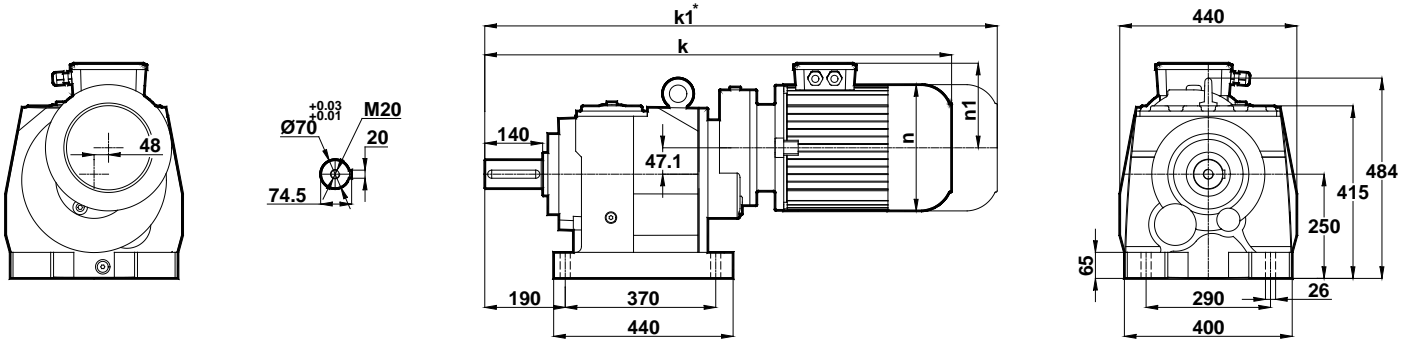

NR674

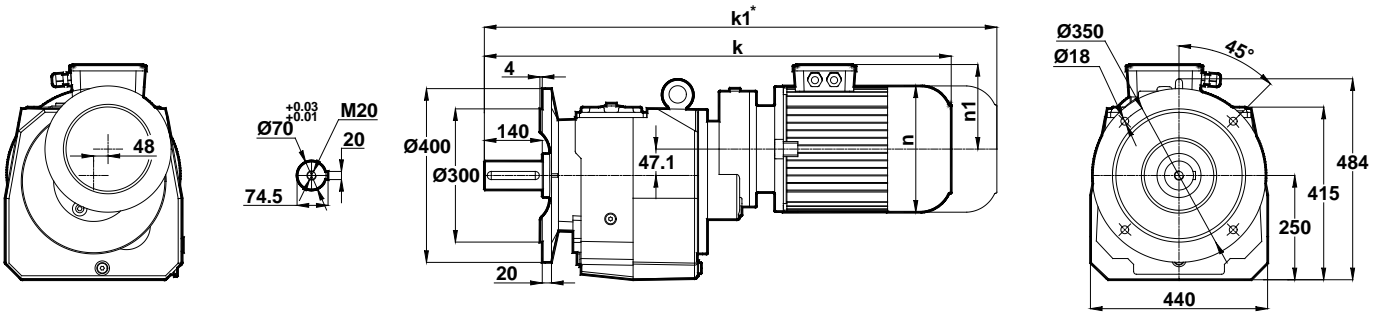

Klemens Kutusu / Terminal Box / Klemmenkasten

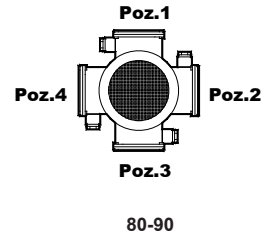

Motor Büyüklüğü / Motor Size / Motorbaugroße			
	80	90S	90L
k	827	855	880
k1	947	980	1005
n	156	176	176
n1	118	126	126

Opsiyonel Flanş Ölçüleri / Optional Flange Dimensions / Auswählbare Flanschabmessungen

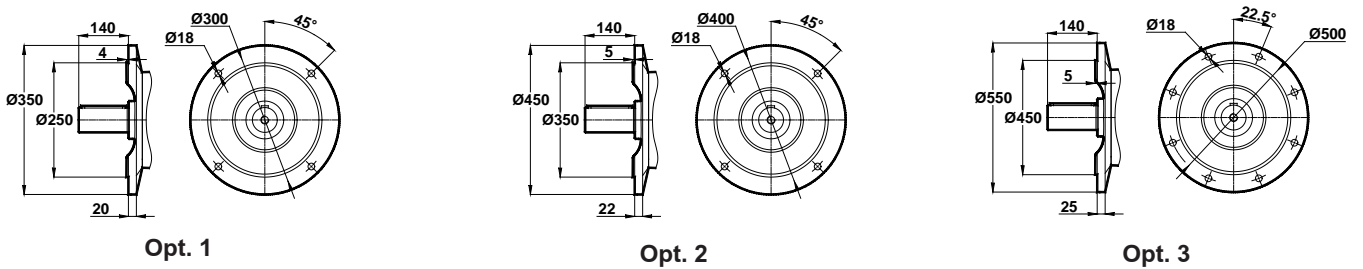

* "k1" Ölçüsü frenli redüktörlere aittir. Dimension "k1" is for motors with brake. Maße "k1" ist für Bremsenmotoren.

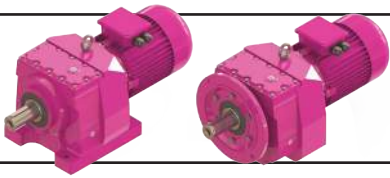

Ölçü Sayfaları Dimension Pages Abmessungsseiten



-Mil ucu çekirme deliği DIN 332 sayfa 2 / Tapped center hole to DIN 332, sheet 2 / Zentrierung mit gewinde DIN 332, Blatt 2

MR675 MR676

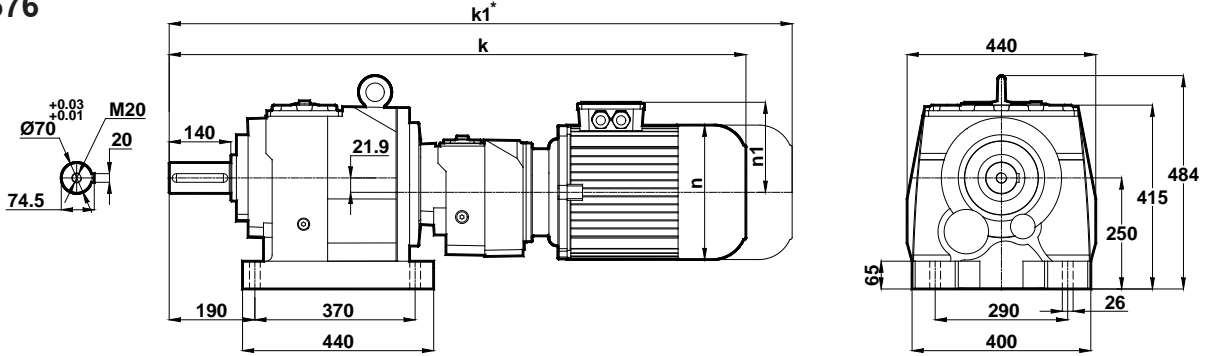

NR675 NR676

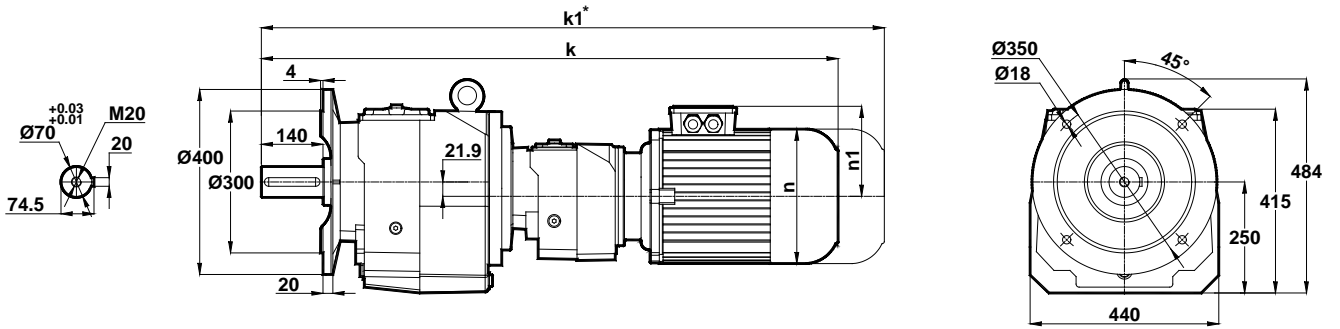

Motor Büyüklüğü / Motor Size / Motorbaugroße	71	80
k	944	972
k1	1064	1092
n	138	156
n1	111	118

Klemens Kutusu / Terminal Box / Klemmenkasten

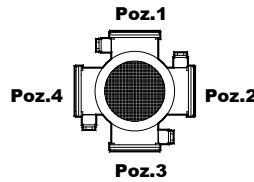

71

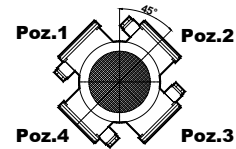

80

Opsiyonel Flanş Ölçüleri / Optional Flange Dimensions / Auswählbare Flanschabmessungen

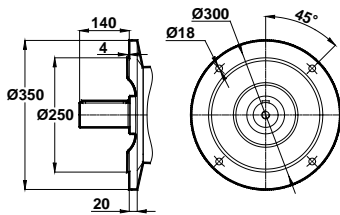

Opt. 1

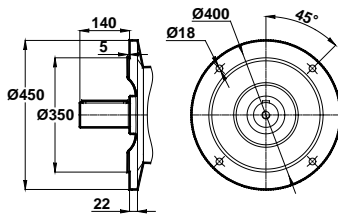

Opt. 2

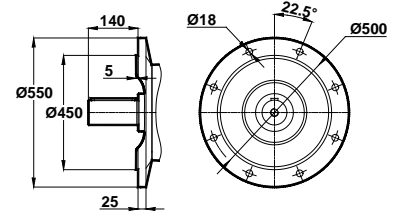

Opt. 3

* " k1 " Ölçüsü frenli redüktörlere aittir. Dimension " k1 " is for motors with brake. Maße " k1 " ist für Bremsenmotoren.

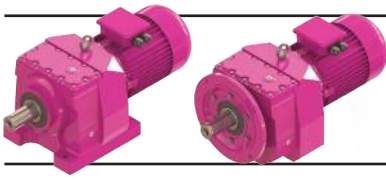

Ölçü Sayfaları Dimension Pages Abmessungsseiten



-Mil ucu çektirme deliği DIN 332 sayfa 2 / Tapped center hole to DIN 332, sheet 2 / Zentrierung mit gewinde DIN 332, Blatt 2

MR772 MR773

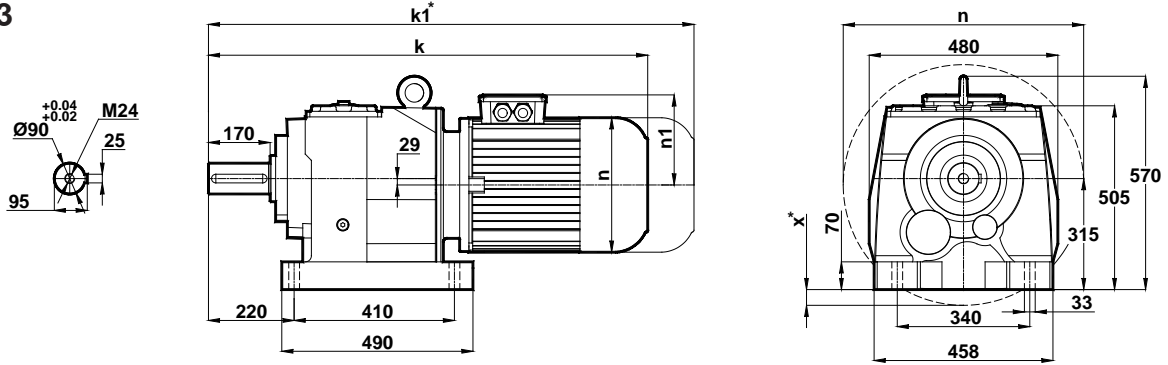

NR772 NR773

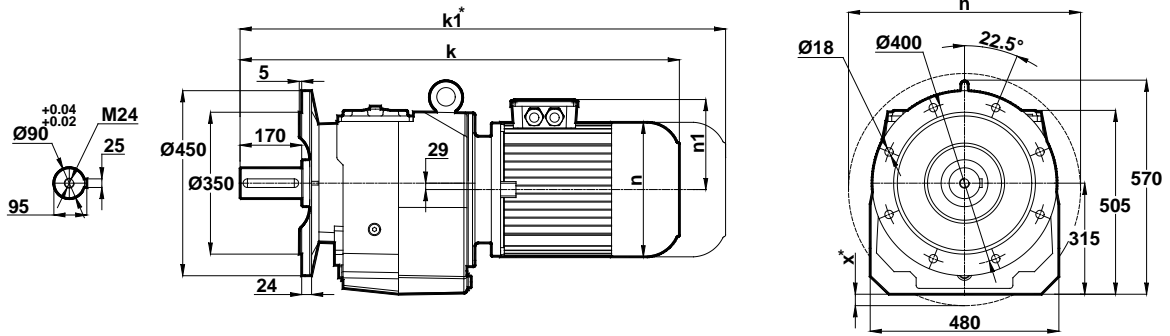

Motor Büyüklüğü / Motor Size / Motorbaugroße										
	132S	132M	160M	160L	180M	180L	200L	225S	225M	250M
k	958	996	1072	1116	1133	1171	1210	1237	1262	1366
k1	1103	1141	1242	1286	1303	1341	1410	1427	1452	-
n	257	257	310	310	348	348	390	434	434	480
n1	168	168	225	225	241	241	275	285	285	322
x	-	-	-	-	-	-	-	-	-	-

Klemens Kutusu / Terminal Box / Klemmenkasten

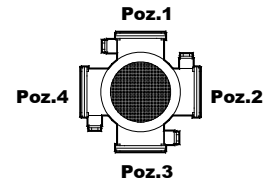

132-160-180-200-225-250

Opsiyonel Flanş Ölçüleri / Optional Flange Dimensions / Auswählbare Flanschabmessungen

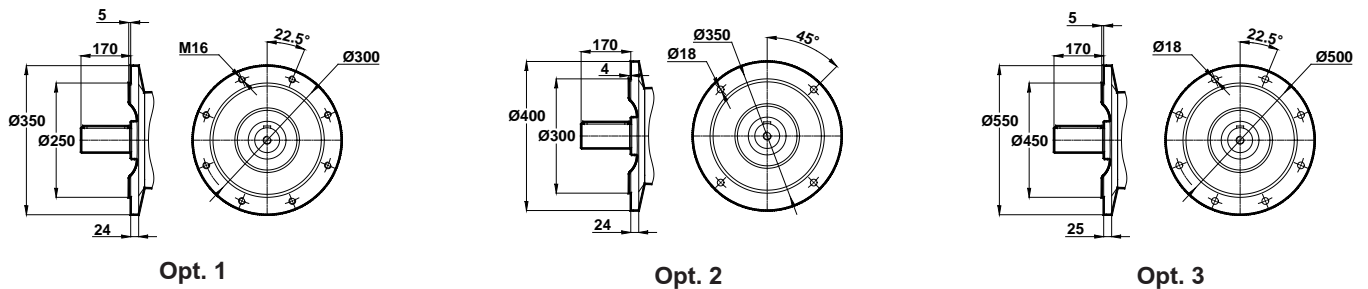

* "k1" Ölçüsü frenli redüktörlere aittir. Dimension "k1" is for motors with brake. Maße "k1" ist für Bremsenmotoren.
x: Motor Ayak bağlantı yüzeyinin altında ise / x: If Motor is lower then foot mounting plane / x: Wenn motor ist niedriger den die Anschlußplatte



Ölçü Sayfaları

Dimension Pages

Abmessungsseiten



-Mil ucu çekirme deliği DIN 332 sayfa 2 / Tapped center hole to DIN 332, sheet 2 / Zentrierung mit gewinde DIN 332, Blatt 2

MR774

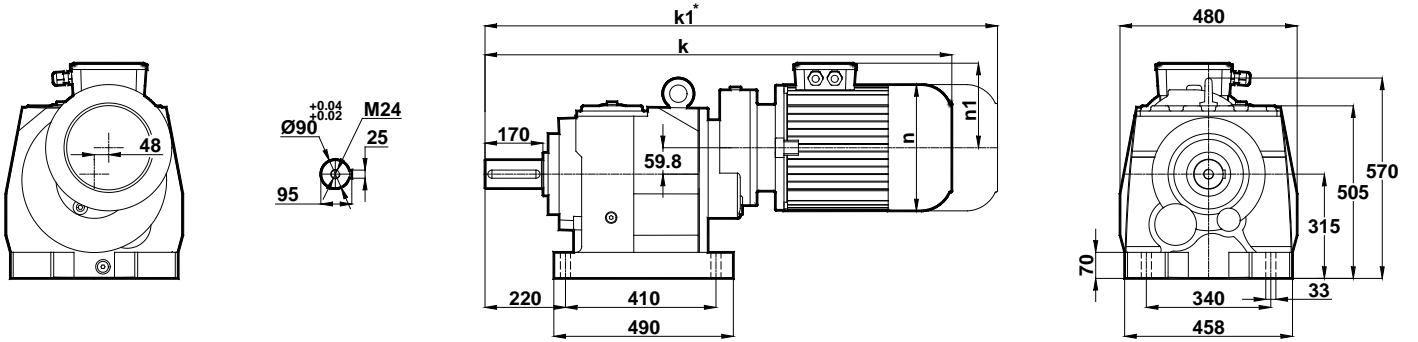

NR774

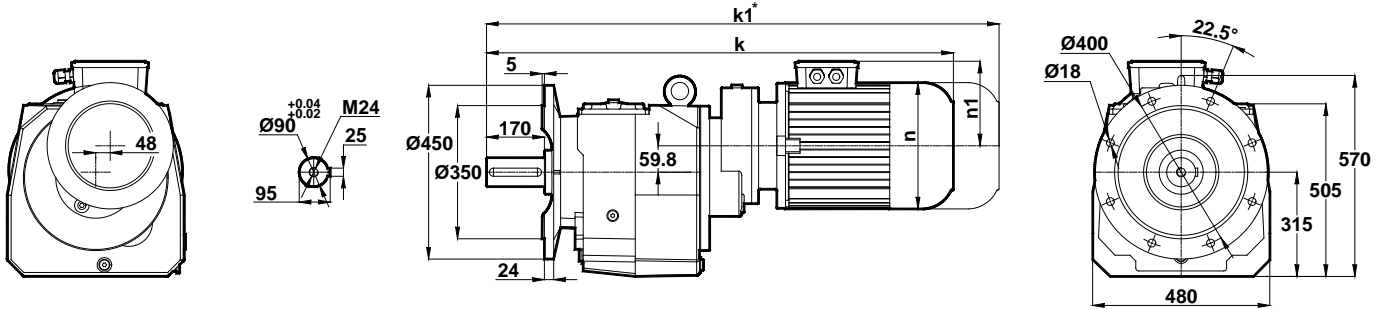

Klemens Kutusu / Terminal Box / Klemmenkasten

Motor Büyüklüğü / Motor Size / Motorbaugroße	80	90S	90L	100L
k	912	940	965	1003
k1	1032	1065	1090	1138
n	156	176	176	194
n1	118	126	126	135

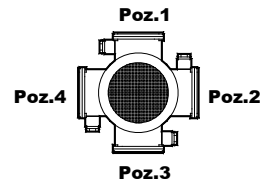

80-90-100

Opsiyonel Flanş Ölçüleri / Optional Flange Dimensions / Auswählbare Flanschabmessungen

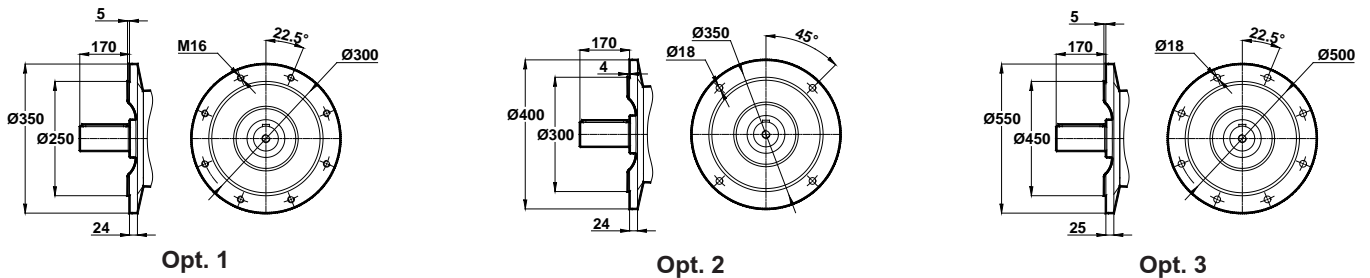

* "k1" Ölçüsü frenli redüktörlere aittir. Dimension "k1" is for motors with brake. Maße "k1" ist für Bremsenmotoren.

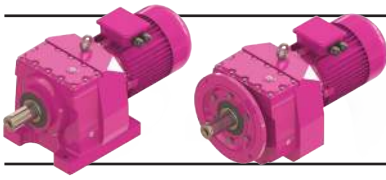

Ölçü Sayfaları Dimension Pages Abmessungsseiten



-Mil ucu çektirme deliği DIN 332 sayfa 2 / Tapped center hole to DIN 332, sheet 2 / Zentrierung mit gewinde DIN 332, Blatt 2

MR775 MR776

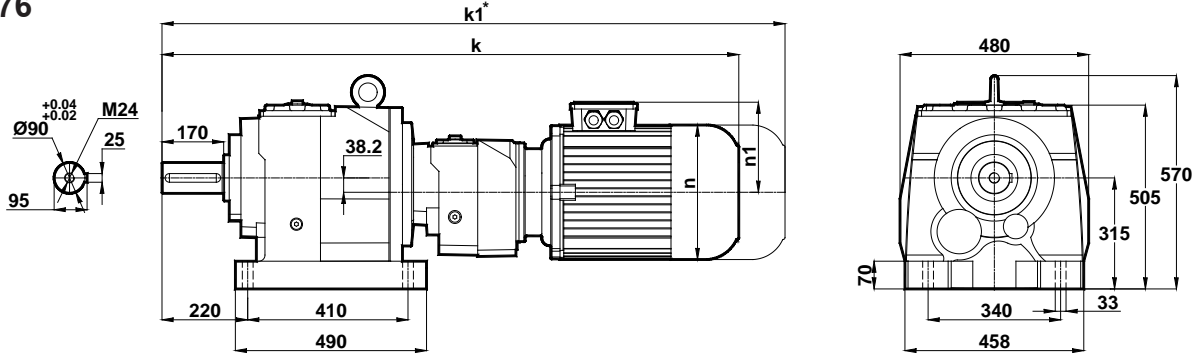

NR775 NR776

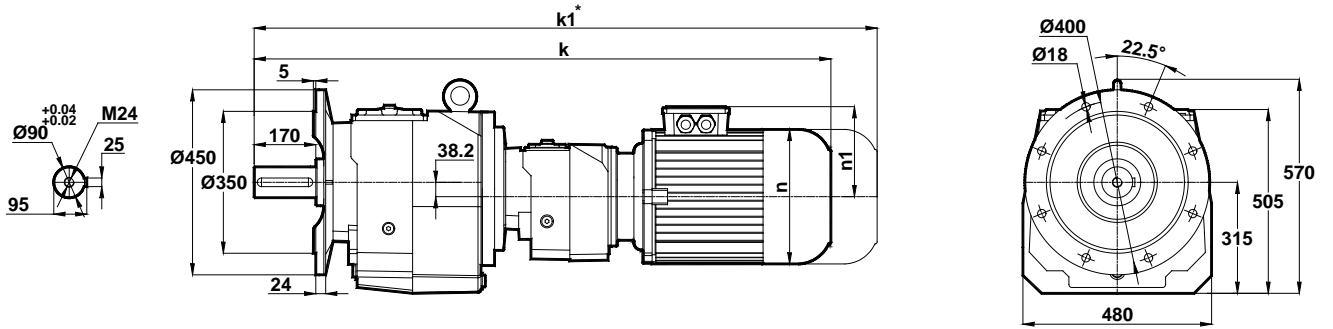

Motor Büyüklüğü / Motor Size / Motorbaugroße	71	80	90S	90L
k	1032	1060	1090	1115
k1	1152	1180	1215	1240
n	138	156	176	176
n1	111	118	126	126

Klemens Kutusu / Terminal Box / Klemmenkasten

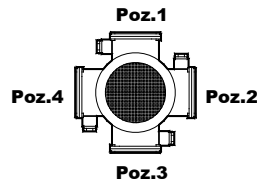

71

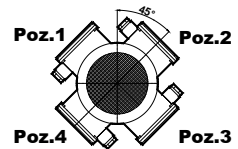

80-90

Opsiyonel Flanş Ölçüleri / Optional Flange Dimensions / Auswählbare Flanschabmessungen

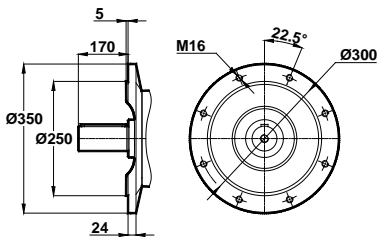

Opt. 1

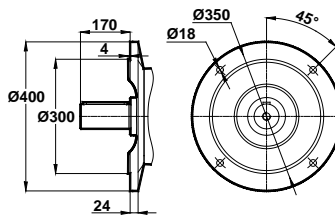

Opt. 2

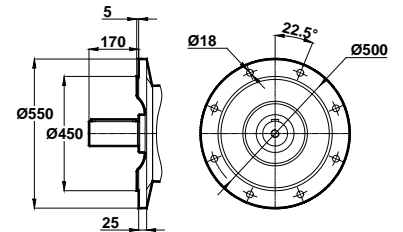

Opt. 3

* " k1 " Ölçüsü frenli redüktörlere aittir. Dimension " k1 " is for motors with brake. Maße " k1 " ist für Bremsenmotoren.

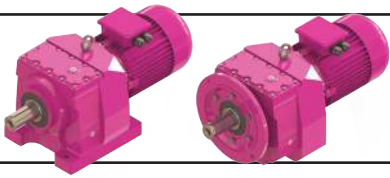

Ölçü Sayfaları Dimension Pages Abmessungsseiten



-Mil ucu çekirme deliği DIN 332 sayfa 2 / Tapped center hole to DIN 332, sheet 2 / Zentrierung mit gewinde DIN 332, Blatt 2

MR872 MR873

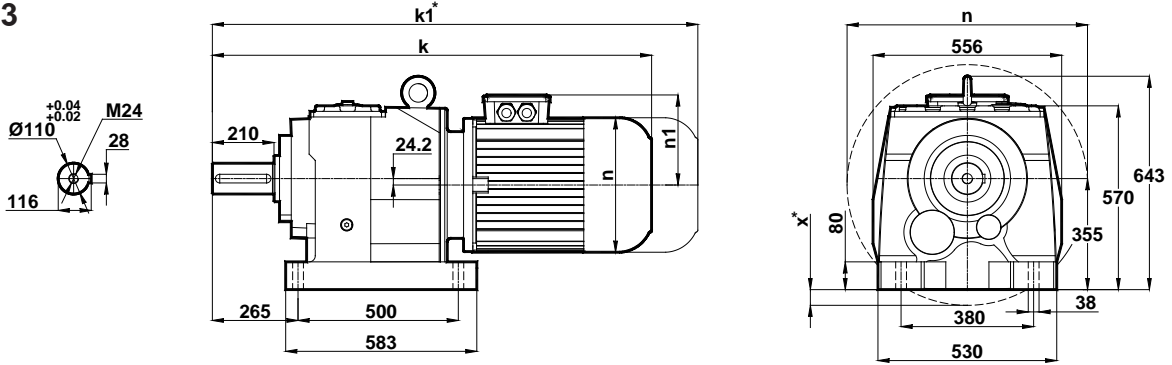

NR872 NR873

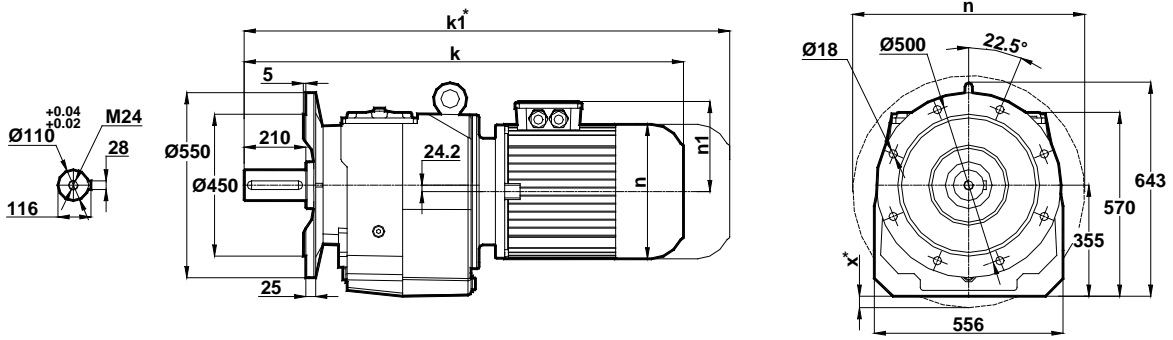

	Motor Büyüklüğü / Motor Size / Motorbaugroße										
	132M	160M	160L	180M	180L	200L	225S	225M	250M	280S	280M
k	1106	1181	1225	1242	1280	1319	1348	1373	1476	1537	1537
k1	1251	1351	1395	1412	1450	1519	1538	1563	-	-	-
n	257	310	310	348	348	390	434	434	480	544	544
n1	168	225	225	241	241	275	285	285	322	350	350
x	-	-	-	-	-	-	-	-	-	-	-

Klemens Kutusu / Terminal Box / Klemmenkasten

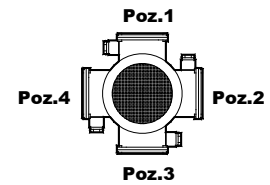

132-160-180-200-225-250-280

Opsiyonel Flanş Ölçüleri / Optional Flange Dimensions / Auswählbare Flanschabmessungen

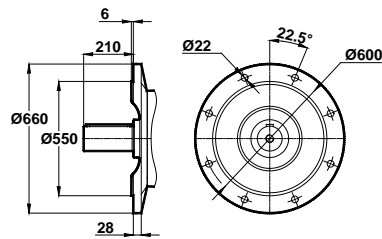

Opt. 1

* " k1 " Ölçüsü frenli redüktörlere aittir. Dimension " k1 " is for motors with brake. Maße " k1 " ist für Bremsenmotoren.

x: Motor, ayak bağlantı yüzeyinin altında ise / x: If Motor is lower then foot mounting plane / x: Wenn motor ist niedriger den die Anschlußplatte

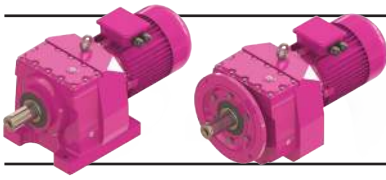

Ölçü Sayfaları Dimension Pages Abmessungsseiten



-Mil ucu çektirme deliği DIN 332 sayfa 2 / Tapped center hole to DIN 332, sheet 2 / Zentrierung mit gewinde DIN 332, Blatt 2

MR874

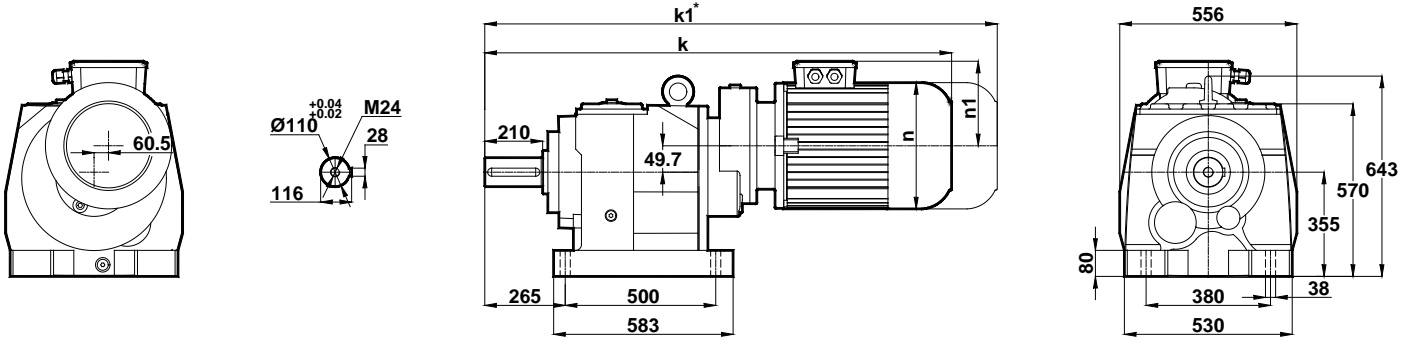

NR874

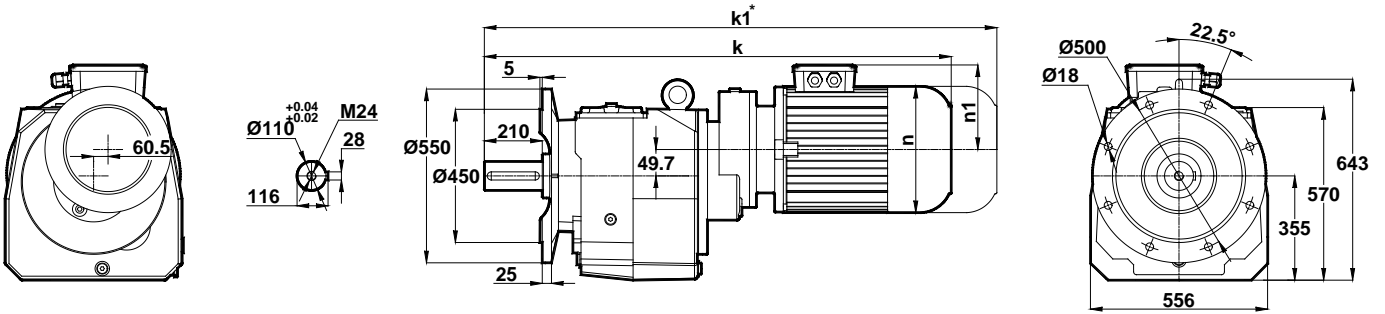

Motor Büyüklüğü / Motor Size / Motorbaugroße	100L	112M	132S	132M
k	1134	1157	1211	1249
k1	1269	1292	1356	1394
n	194	218	257	257
n1	135	146	168	168

Klemens Kutusu / Terminal Box / Klemmenkasten

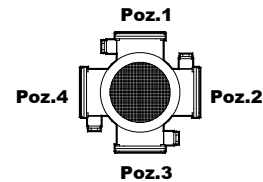

100-112-132

Opsiyonel Flanş Ölçüleri / Optional Flange Dimensions / Auswählbare Flanschabmessungen

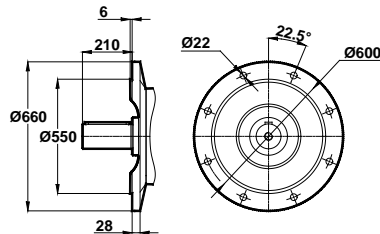

Opt. 1

* "k1" Ölçüsü frenli redüktörlere aittir. Dimension "k1" is for motors with brake. Maße "k1" ist für Bremsenmotoren.

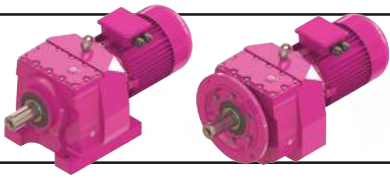

Ölçü Sayfaları Dimension Pages Abmessungsseiten



-Mil ucu çekirme deliği DIN 332 sayfa 2 / Tapped center hole to DIN 332, sheet 2 / Zentrierung mit gewinde DIN 332, Blatt 2

MR875 MR876

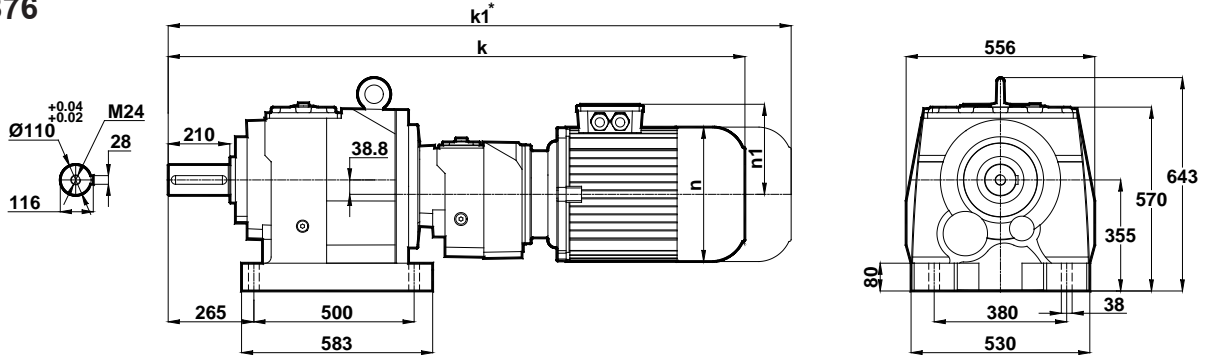

NR875 NR876

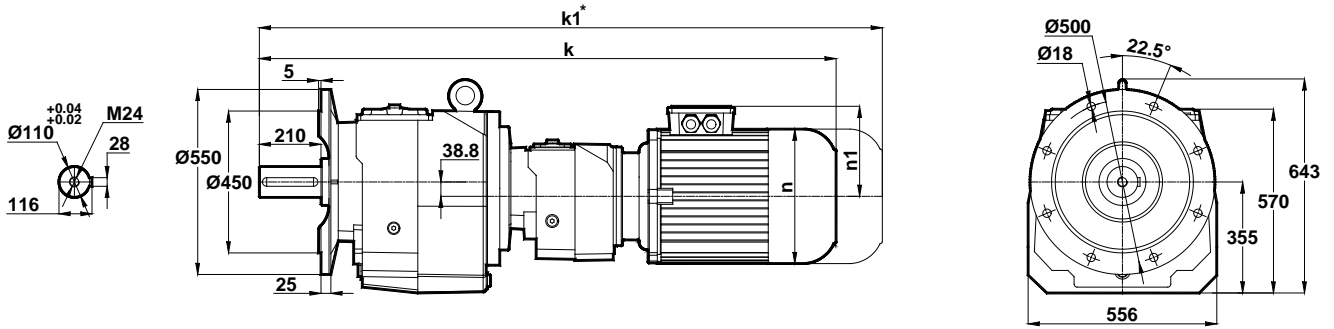

Klemens Kutusu / Terminal Box / Klemmenkasten

Motor Büyüklüğü / Motor Size / Motorbaugroße	71	80	90S	90L	100L
k	1149	1177	1207	1232	1272
k1	1269	1297	1332	1357	1407
n	138	156	176	176	194
n1	111	118	126	126	135

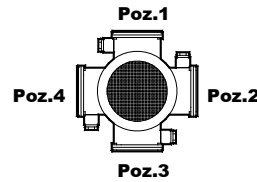

71-100

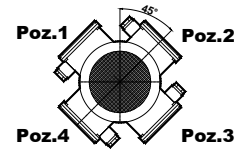

80-90

Opsiyonel Flanş Ölçüleri / Optional Flange Dimensions / Auswählbare Flanschabmessungen

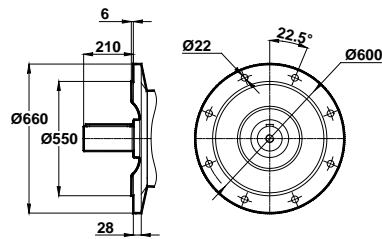

Opt. 1

* " k1 " Ölçüsü frenli redüktörlere aittir. Dimension " k1 " is for motors with brake. Maße " k1 " ist für Bremsenmotoren.

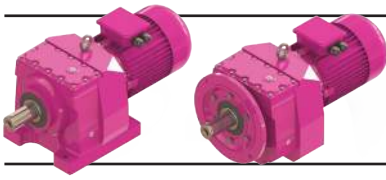

Ölçü Sayfaları Dimension Pages Abmessungsseiten



-Mil ucu çektirme deliği DIN 332 sayfa 2 / Tapped center hole to DIN 332, sheet 2 / Zentrierung mit gewinde DIN 332, Blatt 2

MR972 MR973

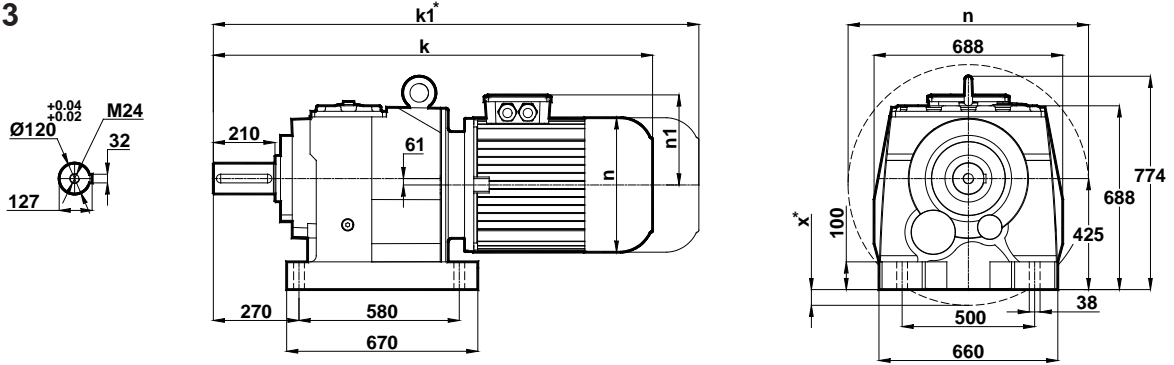

NR972 NR973

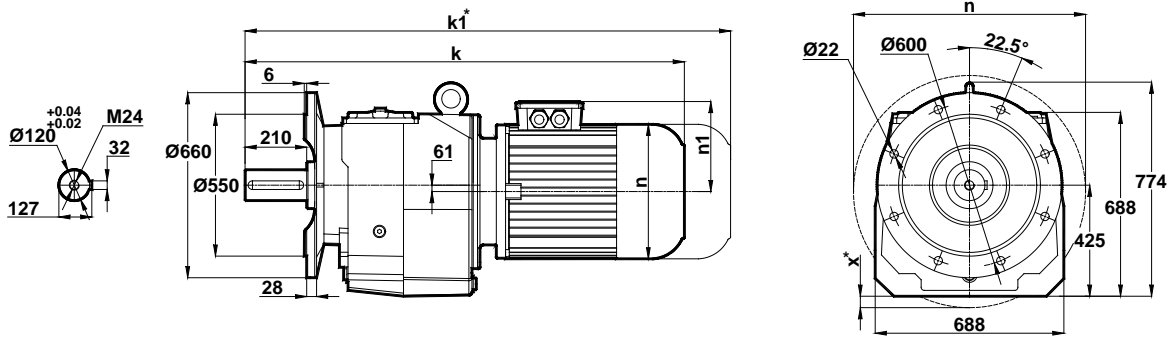

Motor Büyüklüğü / Motor Size / Motorbaugroße												
	160M	160L	180M	180L	200L	225S	225M	250M	280S	280M	315S	315M
k	1248	1292	1308	1346	1385	1403	1426	1529	1590	1590	1702	1754
k1	1418	1462	1478	1516	1585	1593	1616	-	-	-	-	-
n	310	310	348	348	390	434	434	480	544	544	614	614
n1	225	225	241	241	275	285	285	322	350	350	510	510
x	-	-	-	-	-	-	-	-	-	-	-	-

Klemens Kutusu / Terminal Box / Klemmenkasten

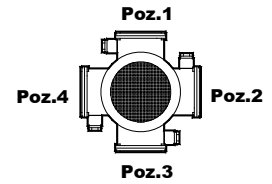

160-180-200-225-250-280-315

* "k1" Ölçüsü frenli redüktörlere aittir. Dimension "k1" is for motors with brake. Maße "k1" ist für Bremsenmotoren.
x: Motor Ayak bağlantı yüzeyinin altında ise / x: If Motor is lower then foot mounting plane / x: Wenn motor ist niedriger den die Anschlußplatte



Ölçü Sayfaları

Dimension Pages

Abmessungsseiten



-Mil ucu çekirme deliği DIN 332 sayfa 2 / Tapped center hole to DIN 332, sheet 2 / Zentrierung mit gewinde DIN 332, Blatt 2

MR974

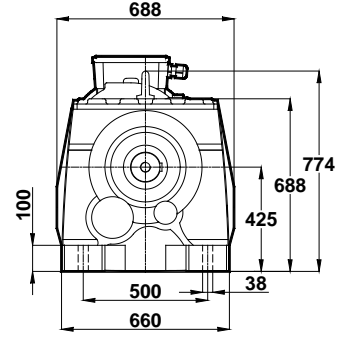
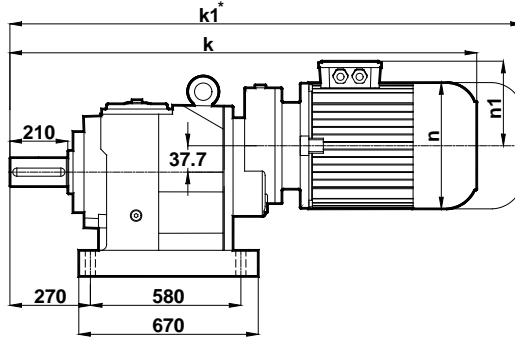
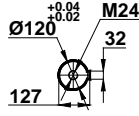
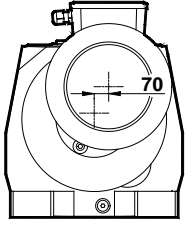

NR974

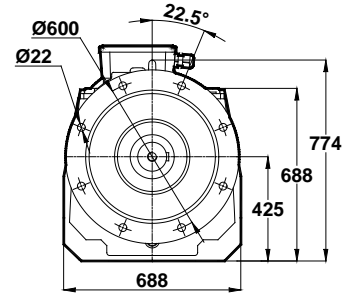
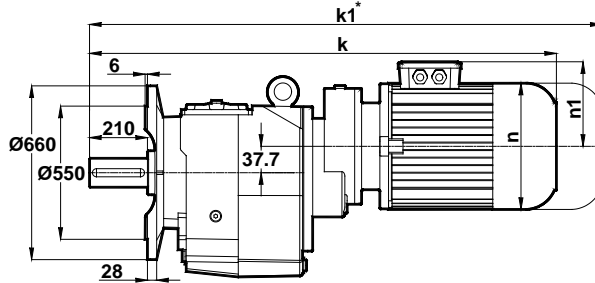
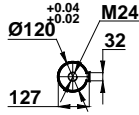
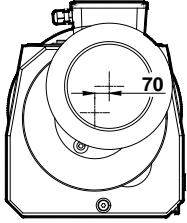

Klemens Kutusu / Terminal Box / Klemmenkasten

Motor Büyüklüğü / Motor Size / Motorbaugroße	100L	112M	132S	132M
k	1234	1257	1311	1349
k1	1369	1392	1456	1494
n	194	218	257	257
n1	135	146	168	168

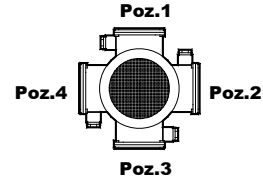

100-112-132

* "k1" Ölçüsü frenli redüktörlere aittir. Dimension "k1" is for motors with brake. Maße "k1" ist für Bremsenmotoren.

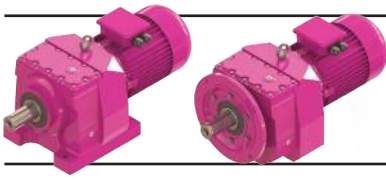

Ölçü Sayfaları Dimension Pages Abmessungsseiten



-Mil ucu çektirme deliği DIN 332 sayfa 2 / Tapped center hole to DIN 332, sheet 2 / Zentrierung mit gewinde DIN 332, Blatt 2

MR975 MR976

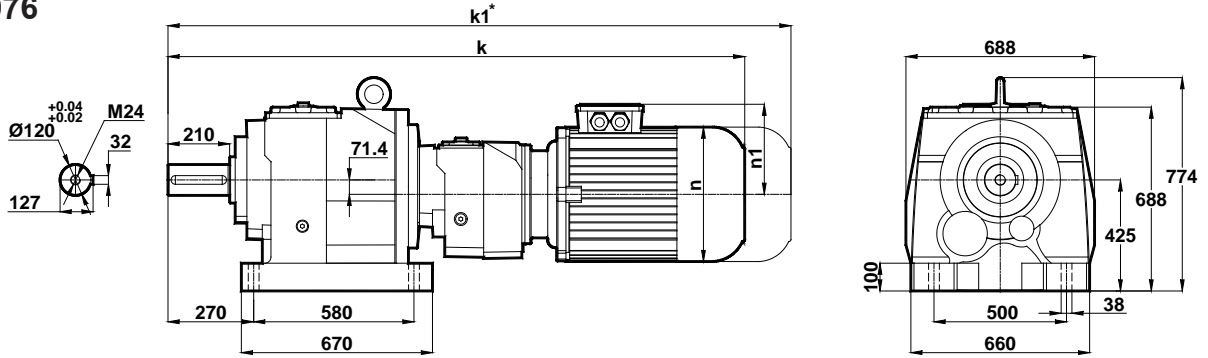

NR975 NR976

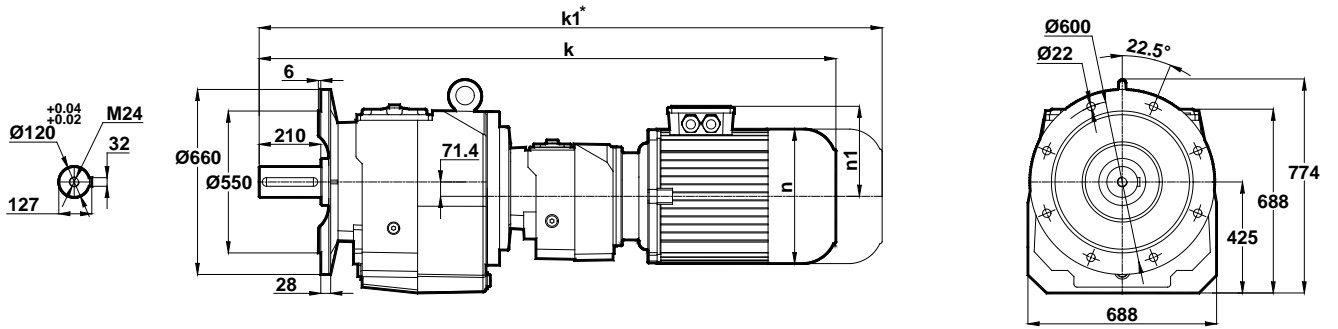

Klemens Kutusu / Terminal Box / Klemmenkasten

Motor Büyüklüğü / Motor Size / Motorbaugroße						
	80	90S	90L	100L	112M	132S
k	1305	1333	1358	1393	1416	1470
k1	1425	1458	1483	1528	1551	1615
n	156	176	176	194	218	257
n1	118	126	126	135	146	168

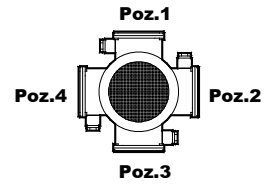

80-90-100-112-132

* "k1" Ölçüsü frenli redüktörlere aittir. Dimension "k1" is for motors with brake. Maße "k1" ist für Bremsenmotoren.

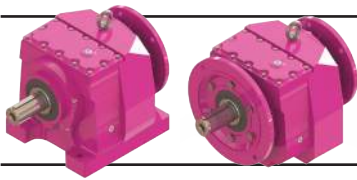

Ölçü Sayfaları

Dimension Pages

Abmessungsseiten



-Mil ucu çektirme deliği DIN 332 sayfa 2 / Tapped center hole to DIN 332, sheet 2 / Zentrierung mit gewinde DIN 332, Blatt 2

MN002-A.. MN003-A..

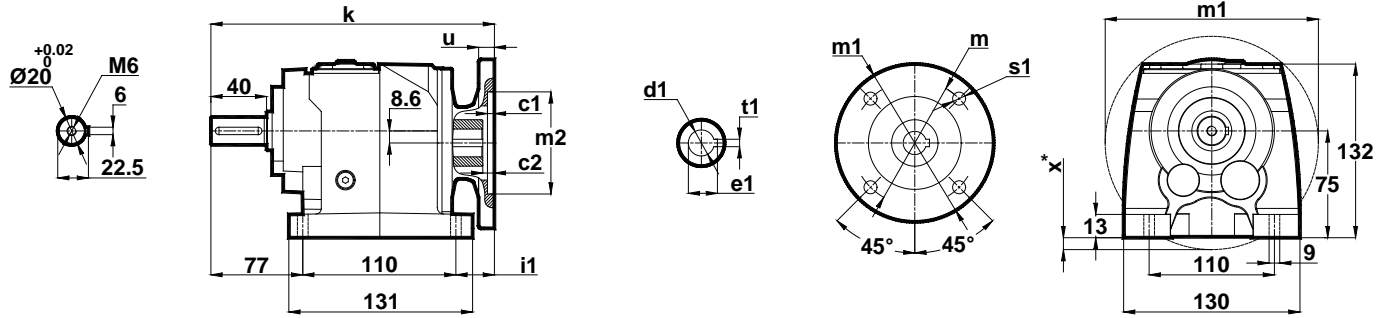

NN002-A.. NN003-A..

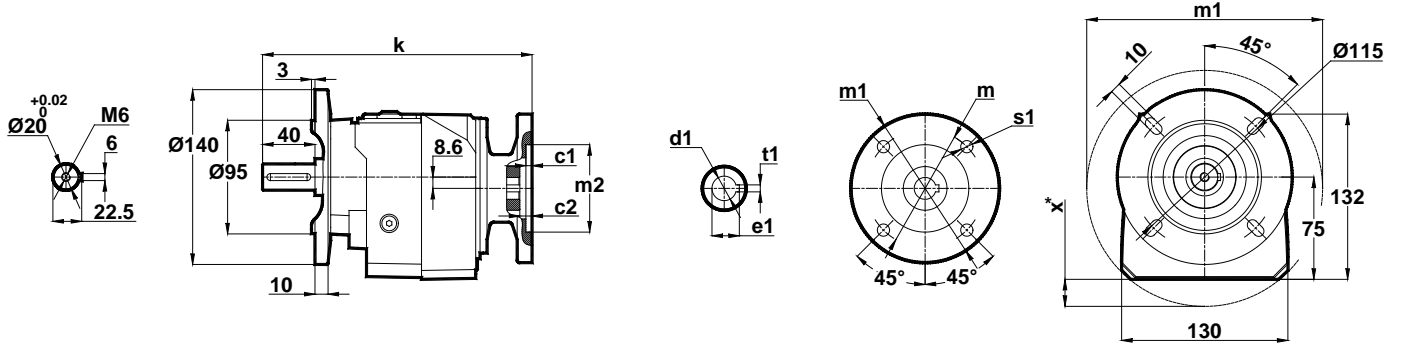

IEC	c1	c2	s1	m	m1	m2	i1	u	k	d1	t1	e1	x
63/B5	3.5	5	10	115	140	95	28	10	214	11	4	12.8	4
71/B5	4	4.5	11	130	160	110	29.5	12	216	14	5	16.3	14
80/B5	4	5	12	165	200	130	44.5	12	231	19	6	21.8	34
90/B5	4	5	12	165	200	130	44.5	12	231	24	8	27.3	34

Opsiyonel Flanş Ölçüleri / Optional Flange Dimensions / Auswählbare Flanschabmessungen

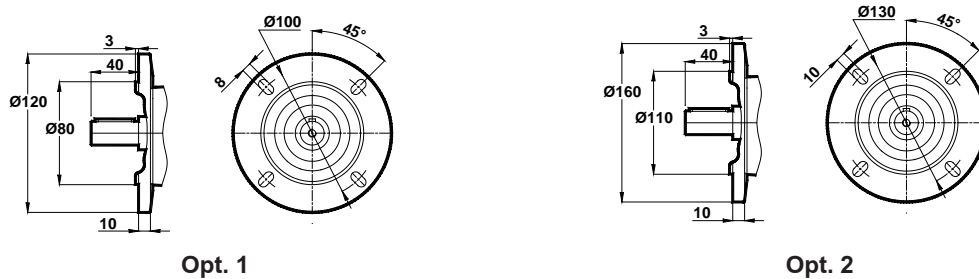

x: Motor flanşı, ayak bağlantı yüzeyinin altında ise / x: If Motor flange is lower then foot mounting plane / x: Wenn motorflansch ist niedriger den die Anschlussplatte

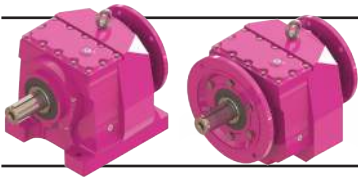

Ölçü Sayfaları

Dimension Pages

Abmessungsseiten



-Mil ucu çektirme deliği DIN 332 sayfa 2 / Tapped center hole to DIN 332, sheet 2 / Zentrierung mit gewinde DIN 332, Blatt 2

MN002-B..
MN003-B..

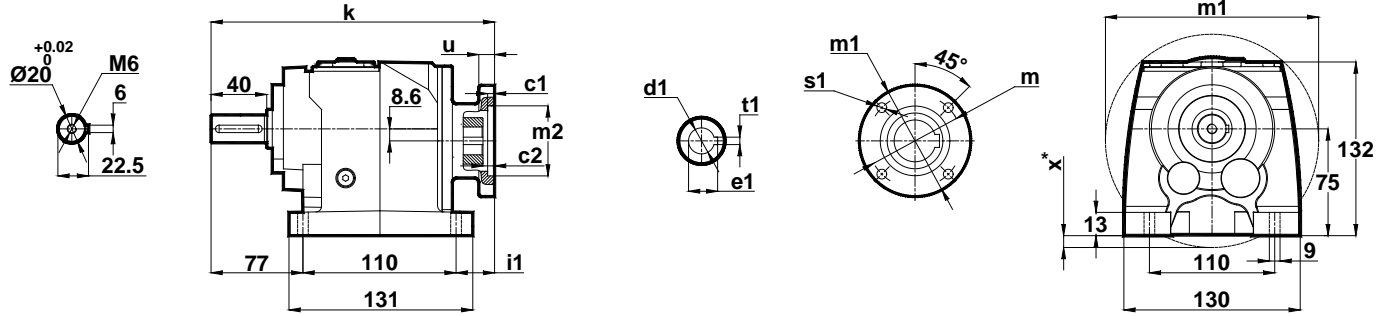

NN002-B..
NN003-B..

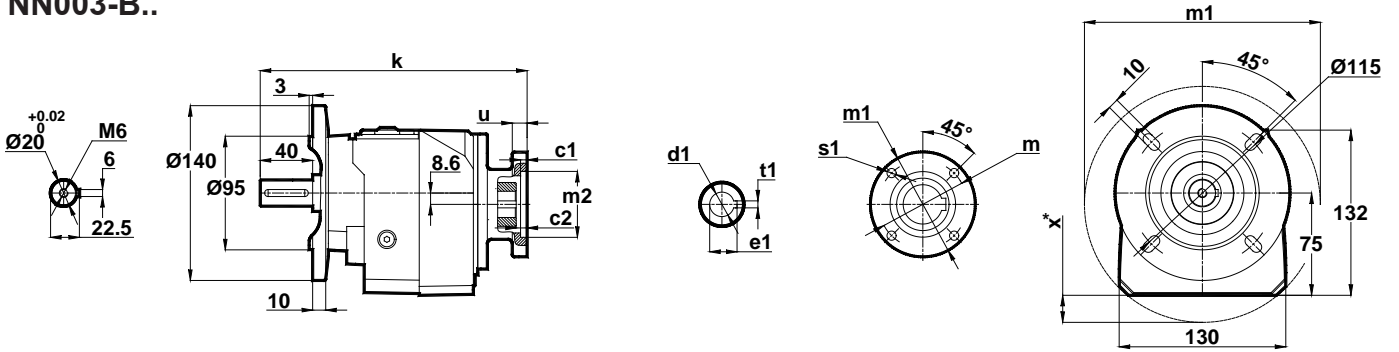

IEC	c1	c2	s1	m	m1	m2	i1	u	k	d1	t1	e1	x
63/B14	2.5	5	5.5	75	90	60	28	10	214	11	4	12.8	-
71/B14	3	4.5	7	85	105	70	29.5	10	216	14	5	16.3	-
80/B14	4	5	7	100	120	80	44.5	12	231	19	6	21.8	-
90/B14	4	5	9	115	140	95	44.5	12	231	24	8	27.3	4

Opsiyonel Flanş Ölçüleri / Optional Flange Dimensions / Auswählbare Flanschabmessungen

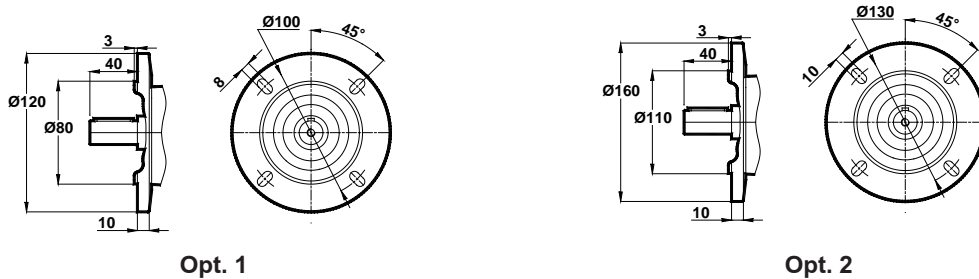

x: Motor flanşı, ayak bağlantı yüzeyinin altında ise / x: If Motor flange is lower then foot mounting plane / x: Wenn motorflansch ist niedriger den die Anschlussplatte

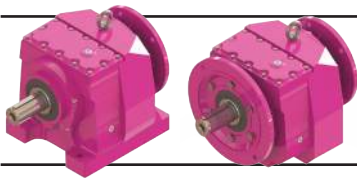

Ölçü Sayfaları

Dimension Pages

Abmessungsseiten



-Mil ucu çektirme deliği DIN 332 sayfa 2 / Tapped center hole to DIN 332, sheet 2 / Zentrierung mit gewinde DIN 332, Blatt 2

MN102-A.. MN103-A..

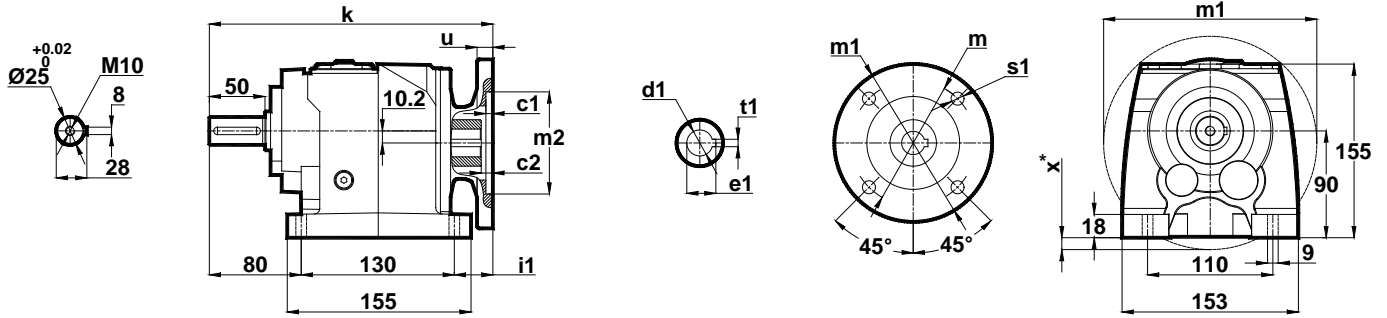

NN102-A.. NN103-A..

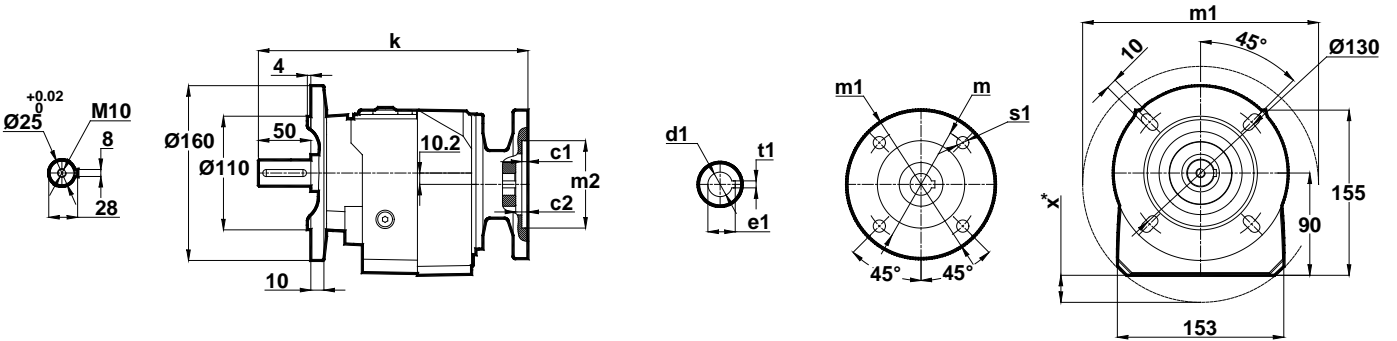

IEC	c1	c2	s1	m	m1	m2	i1	u	k	d1	t1	e1	x
63/B5	4	7	10	115	140	95	28.5	12	240	11	4	12.8	-
71/B5	4	4.5	12	130	160	110	28.5	12	240	14	5	16.3	0.5
80/B5	4	5	12	165	200	130	43.5	12	255	19	6	21.8	20
90/B5	4	5	12	165	200	130	43.5	12	255	24	8	27.3	20

Opsiyonel Flanş Ölçüleri / Optional Flange Dimensions / Auswählbare Flanschabmessungen

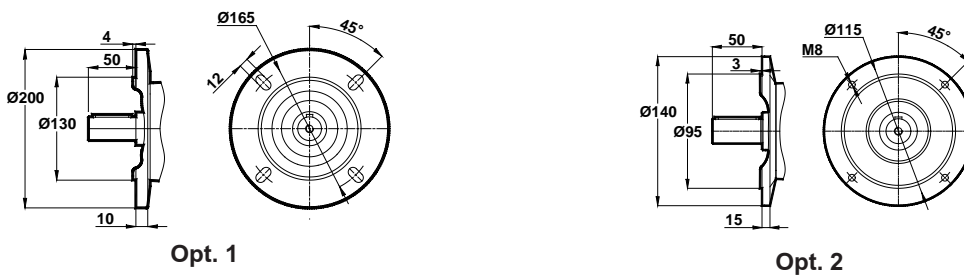

x: Motor flanşı, ayak bağlantı yüzeyinin altında ise / x: If Motor flange is lower then foot mounting plane / x: Wenn motorflansch ist niedriger den die Anschlußplatte

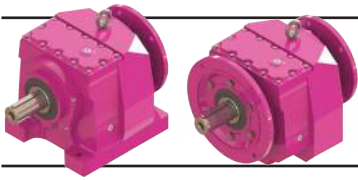

Ölçü Sayfaları

Dimension Pages

Abmessungsseiten



-Mil ucu çektirme deliği DIN 332 sayfa 2 / Tapped center hole to DIN 332, sheet 2 / Zentrierung mit gewinde DIN 332, Blatt 2

MN102-B..

MN103-B..

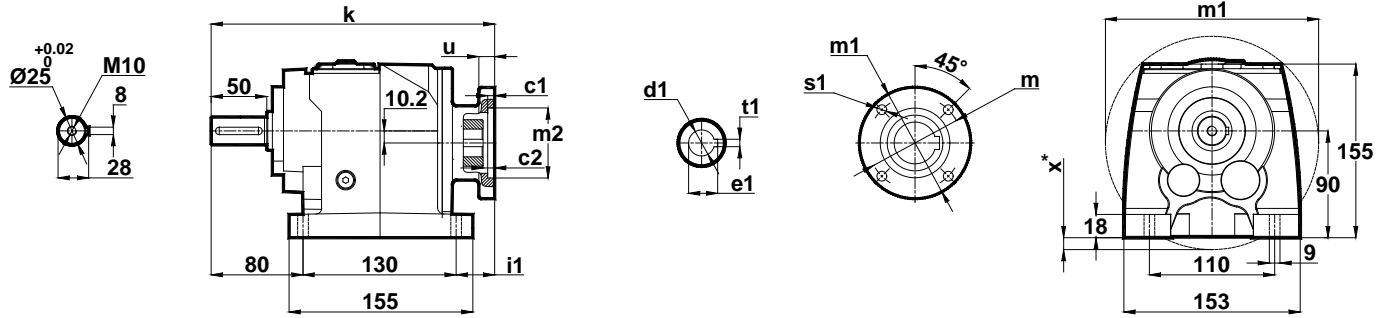

NN102-B..

NN103-B..

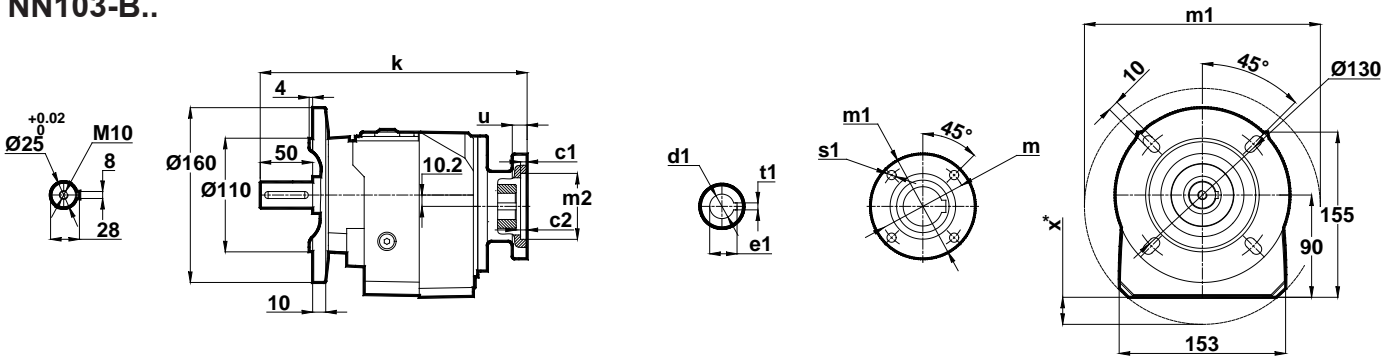

IEC	c1	c2	s1	m	m1	m2	i1	u	k	d1	t1	e1	x
63/B14	2.5	5	5.5	75	90	60	28.5	10	240	11	4	12.8	-
71/B14	3	4.5	7	85	105	70	28.5	10	240	14	5	16.3	-
80/B14	4	4.7	7	100	120	80	43.5	12	255	19	6	21.8	-
90/B14	4	4.7	9	115	140	95	43.5	12	255	24	8	27.3	-

Opsiyonel Flanş Ölçüleri / Optional Flange Dimensions / Auswählbare Flanschabmessungen

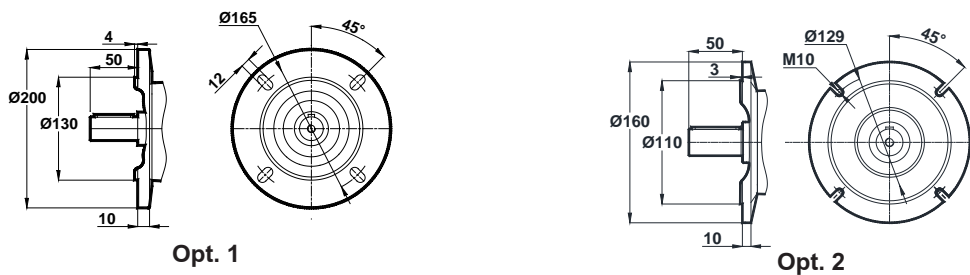

x: Motor flanşı, ayak bağlantı yüzeyinin altında ise / x: If Motor flange is lower then foot mounting plane / x: Wenn motorflansch ist niedriger den die Anschlussplatte

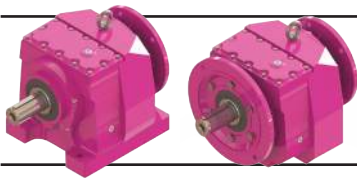

Ölçü Sayfaları

Dimension Pages

Abmessungsseiten



-Mil ucu çektirme deliği DIN 332 sayfa 2 / Tapped center hole to DIN 332, sheet 2 / Zentrierung mit gewinde DIN 332, Blatt 2

MN172-A..

MN173-A..

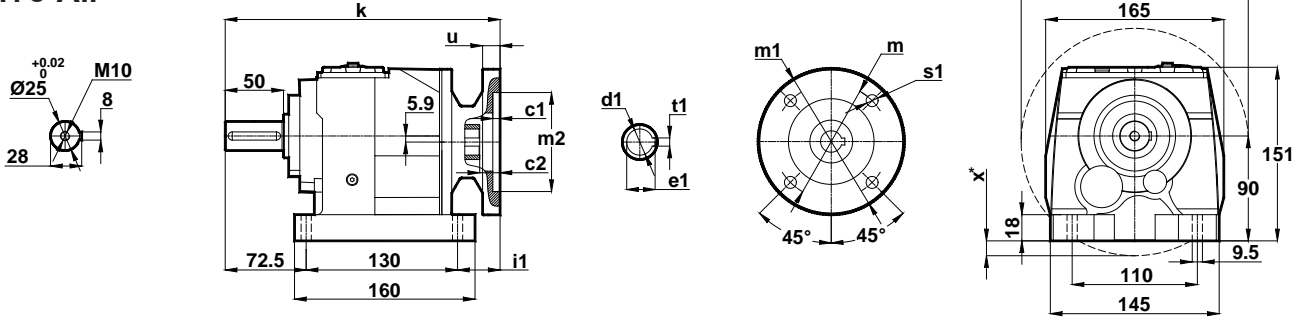

NN172-A..

NN173-A..

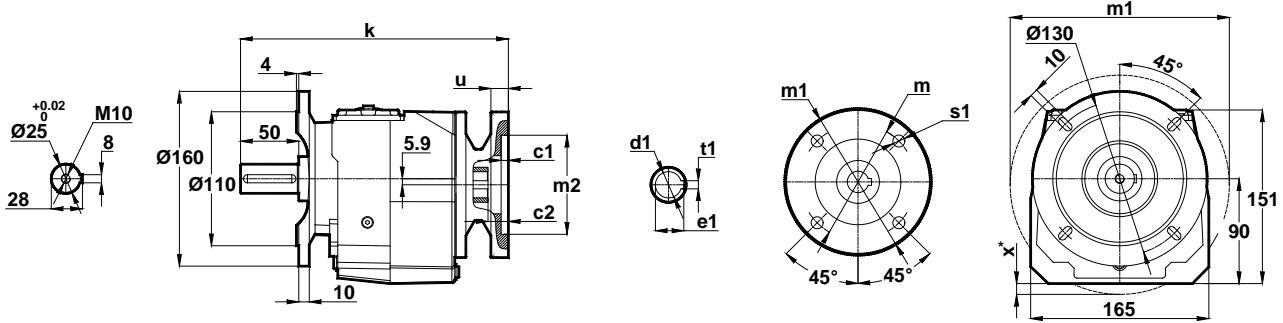

IEC	c1	c2	s1	m	m1	m2	i1	u	k	d1	t1	e1	x
63/B5	3.5	5	10	115	140	95	38.5	10	241	11	4	12.8	-
71/B5	4	4.5	11	130	160	110	40	12	243	14	5	16.3	-
80/B5	4	5	12	165	200	130	55	12	258	19	6	21.8	16
90/B5	4	5	12	165	200	130	55	12	258	24	8	27.3	16
100/B5	4	5	15	215	250	180	66	12	269	28	8	31.3	41
112/B5	4	5	15	215	250	180	66	12	269	28	8	31.3	41

Opsiyonel Flanş Ölçüleri / Optional Flange Dimensions / Auswählbare Flanschabmessungen

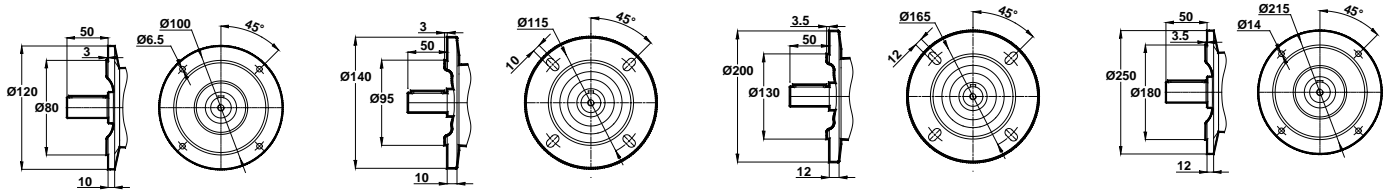

Opt. 1

Opt. 2

Opt. 3

Opt. 4

x: Motor flanş, ayak bağlantı yüzeyinin altında ise / x: If Motor flange is lower then foot mounting plane / x: Wenn motorflansch ist niedriger den die Anschlußplatte

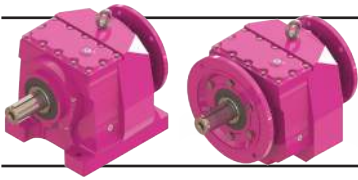

Ölçü Sayfaları

Dimension Pages

Abmessungsseiten



-Mil ucu çektirme deliği DIN 332 sayfa 2 / Tapped center hole to DIN 332, sheet 2 / Zentrierung mit gewinde DIN 332, Blatt 2

MN172-B..

MN173-B..

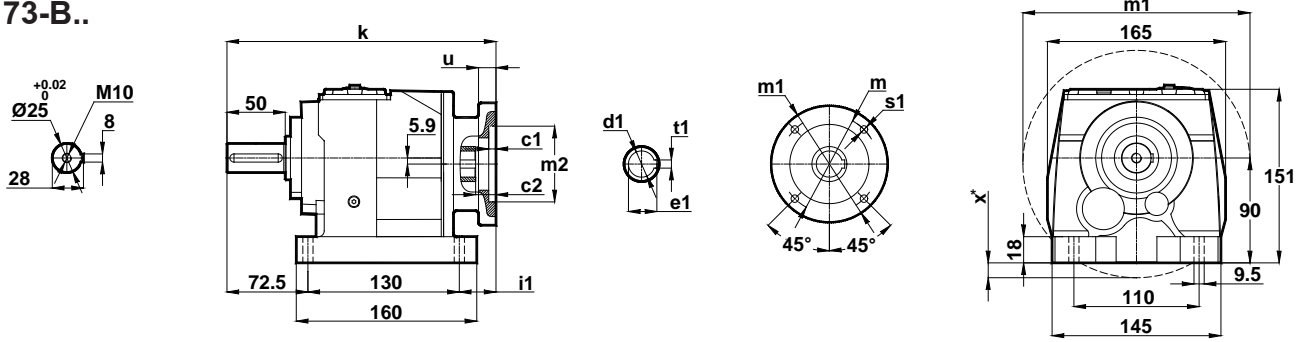

NN172-B..

NN173-B..

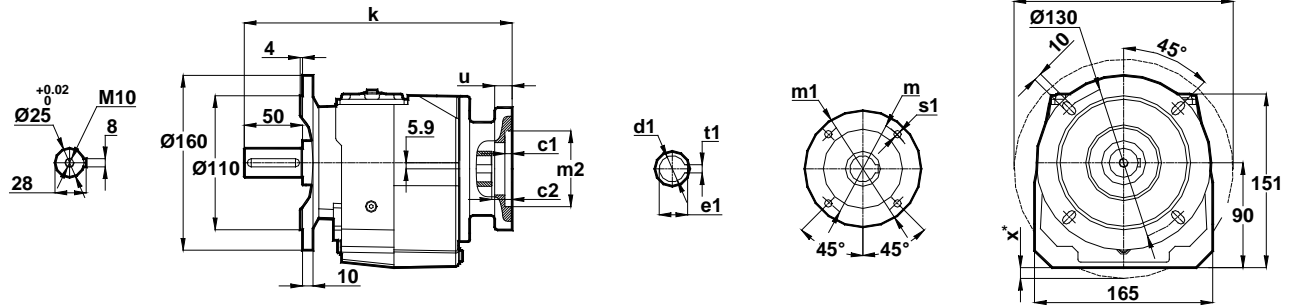

IEC	c1	c2	s1	m	m1	m2	i1	u	k	d1	t1	e1	x
71/B14	3	4.5	7	85	105	70	40	10	243	14	5	16.3	-
80/B14	4	5	7	100	120	80	55	120	258	19	6	21.8	-
90/B14	4	5	9	115	140	95	55	12	258	24	8	27.3	-
100/B14	4	5.5	9	130	160	110	66	12	269	28	8	31.3	-
112/B14	4	5.5	9	130	160	110	66	12	269	28	8	31.3	-

Opsiyonel Flanş Ölçüleri / Optional Flange Dimensions / Auswählbare Flanschabmessungen

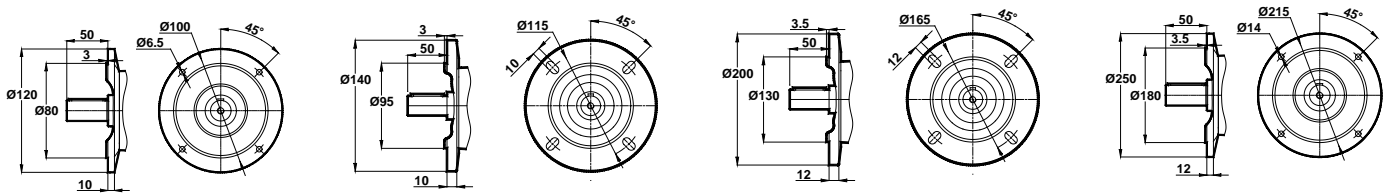

Opt. 1

Opt. 2

Opt. 3

Opt. 4

x: Motor flanşı, ayak bağlantı yüzeyinin altında ise / x: If Motor flange is lower than foot mounting plane / x: Wenn motorflansch ist niedriger den die Anschlußplatte

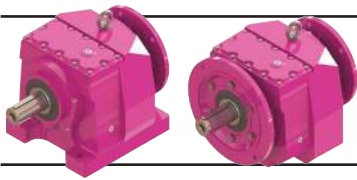

Ölçü Sayfaları

Dimension Pages

Abmessungsseiten



-Mil ucu çektirme deliği DIN 332 sayfa 2 / Tapped center hole to DIN 332, sheet 2 / Zentrierung mit gewinde DIN 332, Blatt 2

MN202-A.. MN203-A..

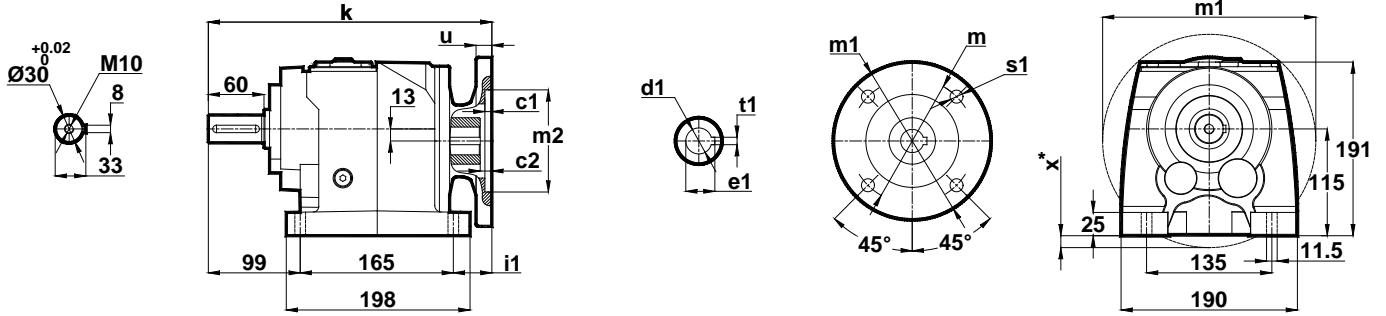

NN202-A.. NN203-A..

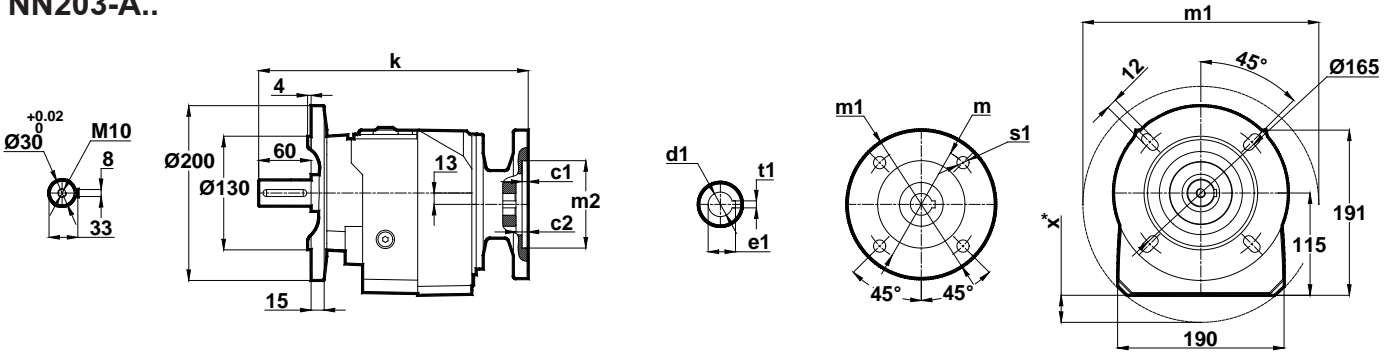

IEC	c1	c2	s1	m	m1	m2	i1	u	k	d1	t1	e1	x
63/B5	4	5	9	115	140	95	58.5	12	323	11	4	12.8	-
71/B5	4	8.5	11	130	160	110	29.5	12	294	14	5	16.3	-
80/B5	4	5	12	165	200	130	58.5	12	323	19	6	21.8	-
90/B5	4	5	12	165	200	130	58.5	12	323	24	8	27.3	-
100/B5	4	5.5	15	215	250	180	51.5	12	316	28	8	31.3	23
112/B5	4	5.5	15	215	250	180	51.5	12	316	28	8	31.3	23

Opsiyonel Flanş Ölçüleri / Optional Flange Dimensions / Auswählbare Flanschabmessungen

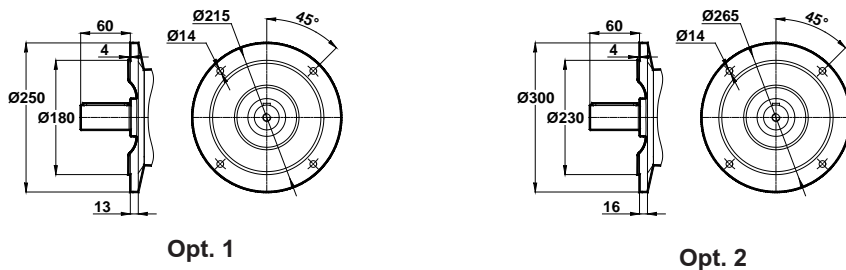

x: Motor flanşı, ayak bağlantı yüzeyinin altında ise / x: If Motor flange is lower then foot mounting plane / x: Wenn motorflansch ist niedriger den die Anschlussplatte

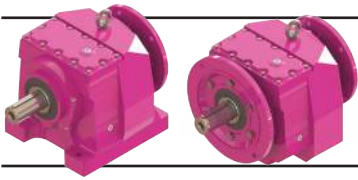

Ölçü Sayfaları

Dimension Pages

Abmessungsseiten



-Mil ucu çektirme deliği DIN 332 sayfa 2 / Tapped center hole to DIN 332, sheet 2 / Zentrierung mit gewinde DIN 332, Blatt 2

MN202-B..

MN203-B..

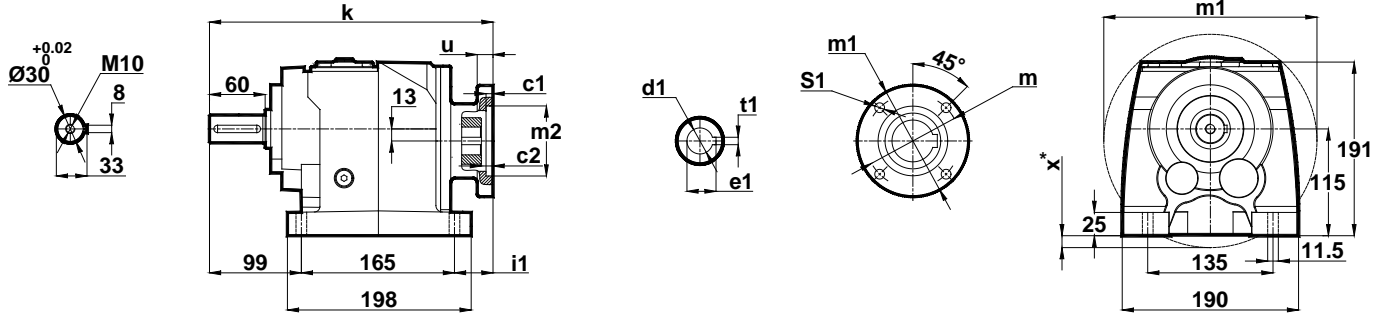

NN202-B..

NN203-B..

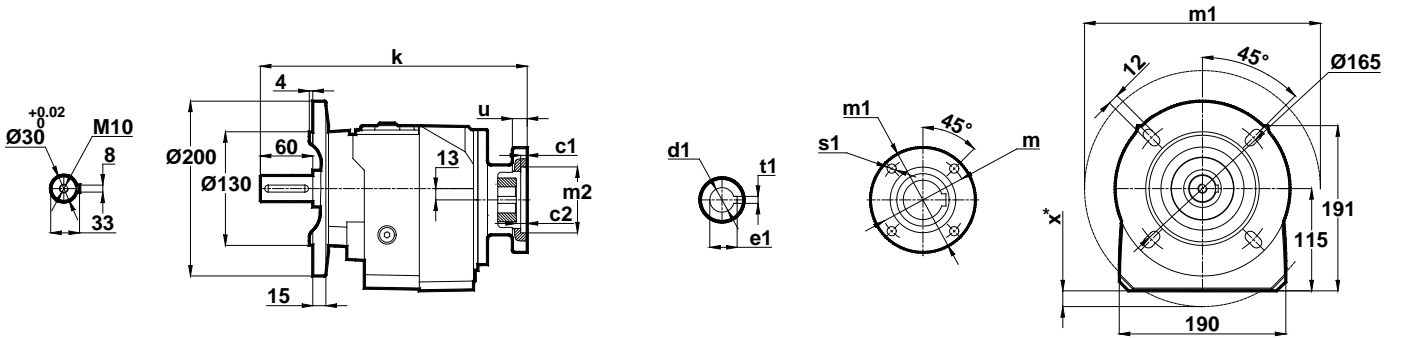

IEC	c1	c2	s1	m	m1	m2	i1	u	k	d1	t1	e1	x
71/B14	3	8.5	7	85	105	70	29.5	10	294	14	5	16.3	-
80/B14	4	5	7	100	120	80	58.5	12	323	19	6	21.8	-
90/B14	4	5	9	115	140	95	58.5	12	323	24	8	27.3	-
100/B14	4	5.5	9	130	160	110	51.5	12	316	28	8	31.3	-
112/B14	4	5.5	9	130	160	110	51.5	12	316	28	8	31.3	-

Opsiyonel Flanş Ölçüleri / Optional Flange Dimensions / Auswählbare Flanschabmessungen

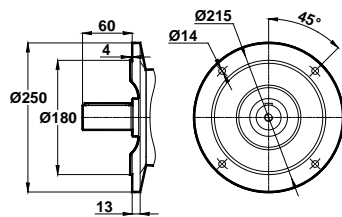

Opt. 1

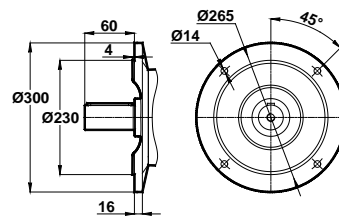

Opt. 2

x: Motor flanşı, ayak bağlantı yüzeyinin altında ise / x: If Motor flange is lower then foot mounting plane / x: Wenn motorflansch ist niedriger den die Anschlußplatte

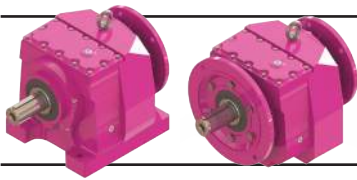

Ölçü Sayfaları Dimension Pages Abmessungsseiten



-Mil ucu çektirme deliği DIN 332 sayfa 2 / Tapped center hole to DIN 332, sheet 2 / Zentrierung mit gewinde DIN 332, Blatt 2

MN272-A.. MN273-A..

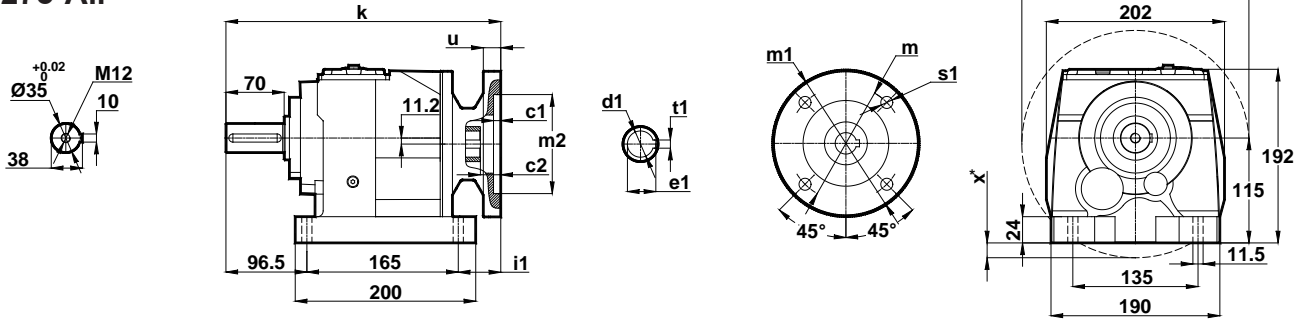

NN272-A.. NN273-A..

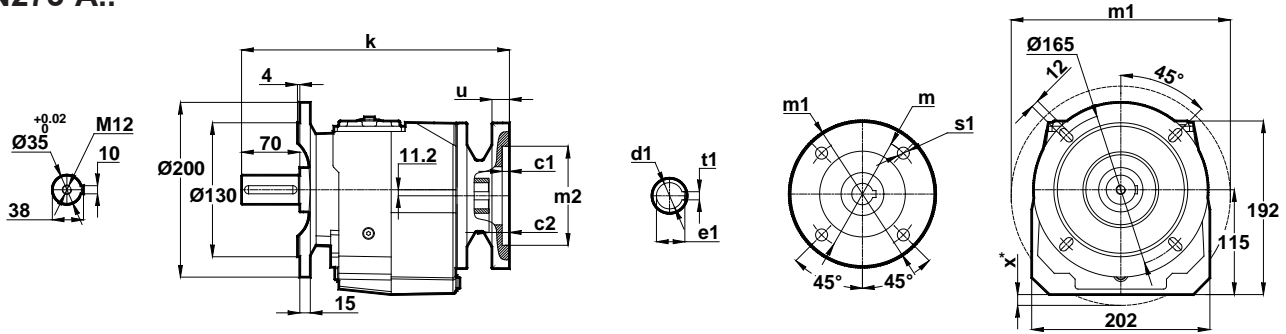

IEC	c1	c2	s1	m	m1	m2	i1	u	k	d1	t1	e1	x
63/B5	4	5	9	115	140	95	62	12	324	11	4	12.8	-
71/B5	4	8.5	11	130	160	110	33	12	295	14	5	16.3	-
80/B5	4	5	12	165	200	130	62	12	324	19	6	21.8	-
90/B5	4	5	12	165	200	130	62	12	324	24	8	27.3	-
100/B5	4	5.5	15	215	250	180	55	12	317	28	8	31.3	22
112/B5	4	5.5	15	215	250	180	55	12	317	28	8	31.3	22

Opsiyonel Flanş Ölçüleri / Optional Flange Dimensions / Auswählbare Flanschabmessungen

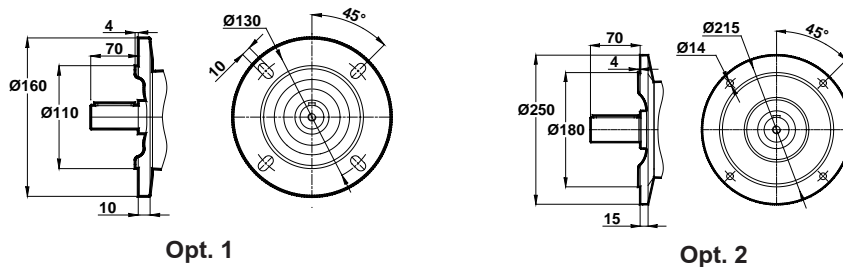

x: Motor flanş, ayak bağlantı yüzeyinin altında ise / x: If Motor flange is lower then foot mounting plane / x: Wenn motorflansch ist niedriger den die Anschlußplatte

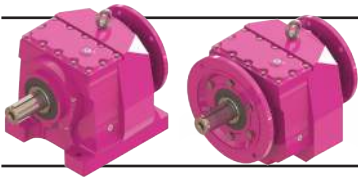

Ölçü Sayfaları

Dimension Pages

Abmessungsseiten



-Mil ucu çektirme deliği DIN 332 sayfa 2 / Tapped center hole to DIN 332, sheet 2 / Zentrierung mit gewinde DIN 332, Blatt 2

MN272-B..
MN273-B..

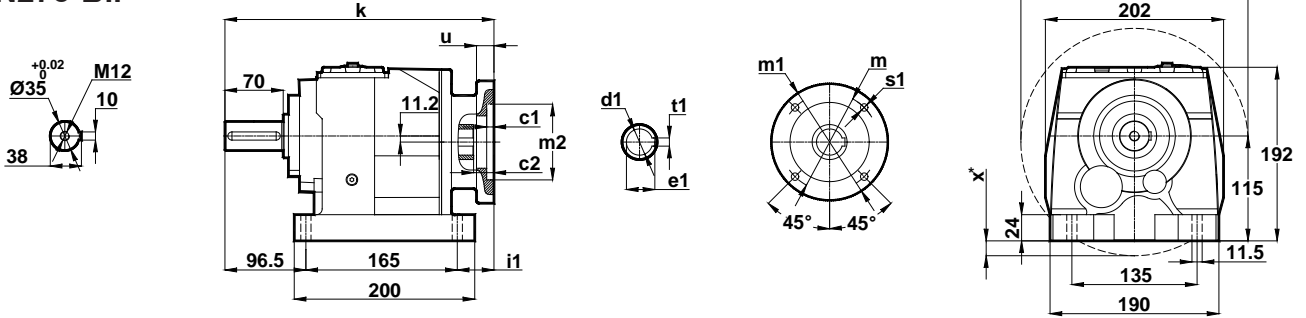

NN272-B..
NN273-B..

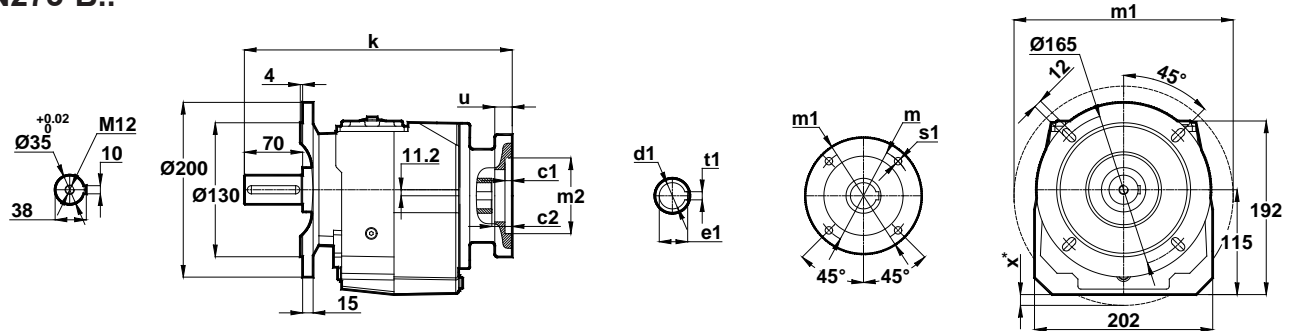

IEC	c1	c2	s1	m	m1	m2	i1	u	k	d1	t1	e1	x
71/B14	3	8.5	7	85	105	70	33	10	295	14	5	16.3	-
80/B14	4	5	7	100	120	80	62	12	324	19	6	21.8	-
90/B14	4	5	9	115	140	95	62	12	324	24	8	27.3	-
100/B14	4	5.5	9	130	160	110	55	12	317	28	8	31.3	-
112/B14	4	5.5	9	130	160	110	55	12	317	28	8	31.3	-

Opsiyonel Flanş Ölçüleri / Optional Flange Dimensions / Auswählbare Flanschabmessungen

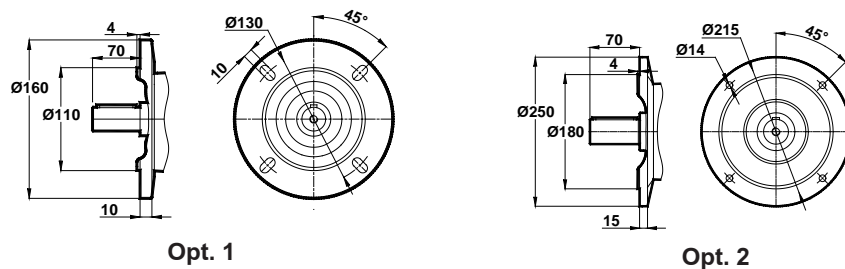

x: Motor flanşı, ayak bağlantı yüzeyinin altında ise / x: If Motor flange is lower than foot mounting plane / x: Wenn motorflansch ist niedriger den die Anschlußplatte

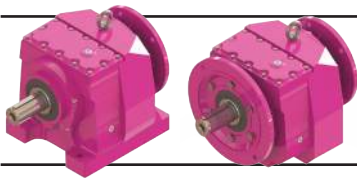

Ölçü Sayfaları

Dimension Pages

Abmessungsseiten



-Mil ucu çektirme deliği DIN 332 sayfa 2 / Tapped center hole to DIN 332, sheet 2 / Zentrierung mit gewinde DIN 332, Blatt 2

MN275-A.. MN276-A..

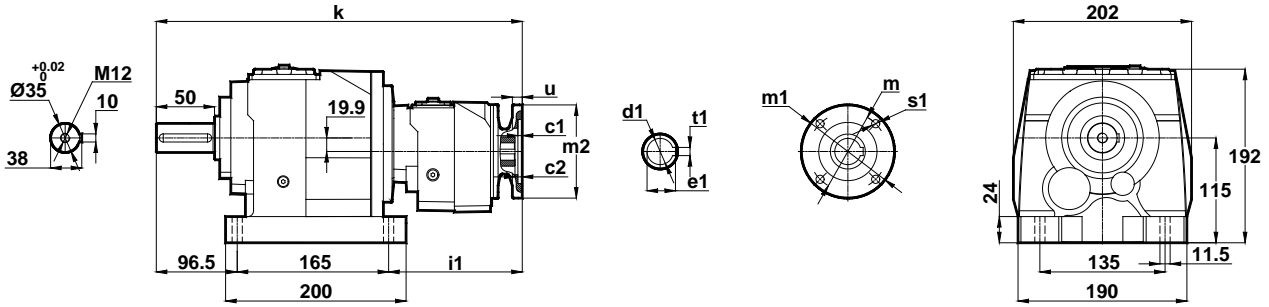

NN275-A.. NN276-A..

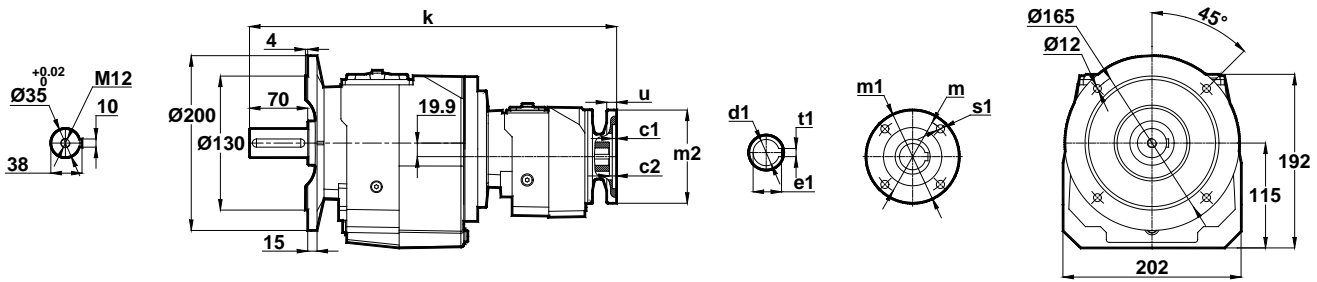

IEC	c1	c2	s1	m	m1	m2	i1	u	k	d1	t1	e1
63/B5	3.5	5	10	115	140	95	177.5	10	439	11	4	12.8
71/B5	4	4.5	11	130	160	110	179	12	441	14	5	16.3

Opsiyonel Flanş Ölçüleri / Optional Flange Dimensions / Auswählbare Flanschabmessungen

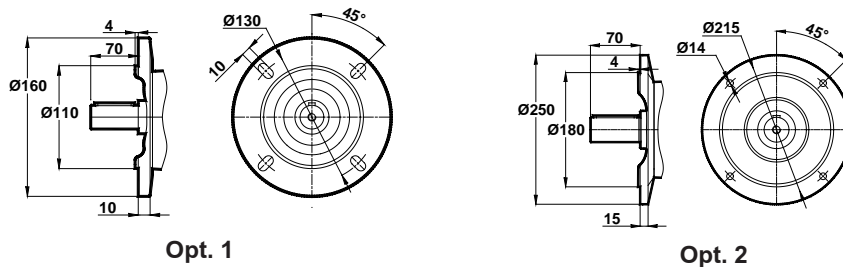

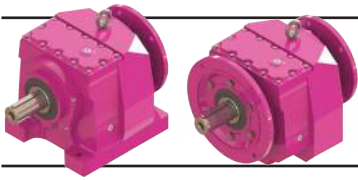

Ölçü Sayfaları

Dimension Pages

Abmessungsseiten



-Mil ucu çektirme deliği DIN 332 sayfa 2 / Tapped center hole to DIN 332, sheet 2 / Zentrierung mit gewinde DIN 332, Blatt 2

MN275-B..
MN276-B..

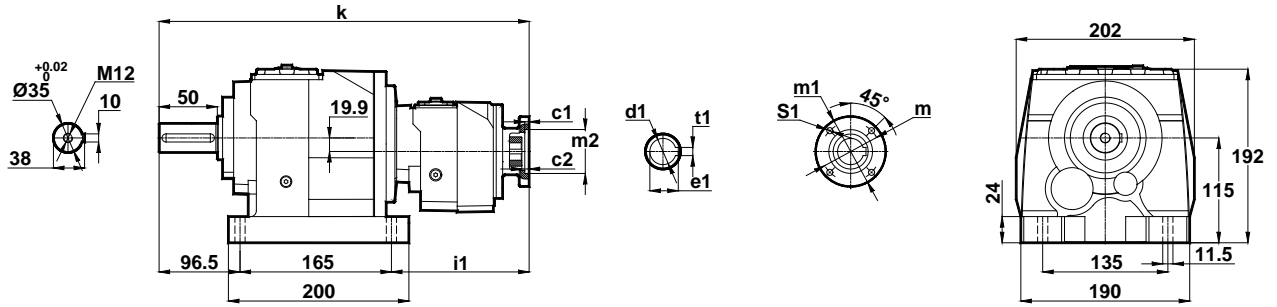

NN275-B..
NN276-B..

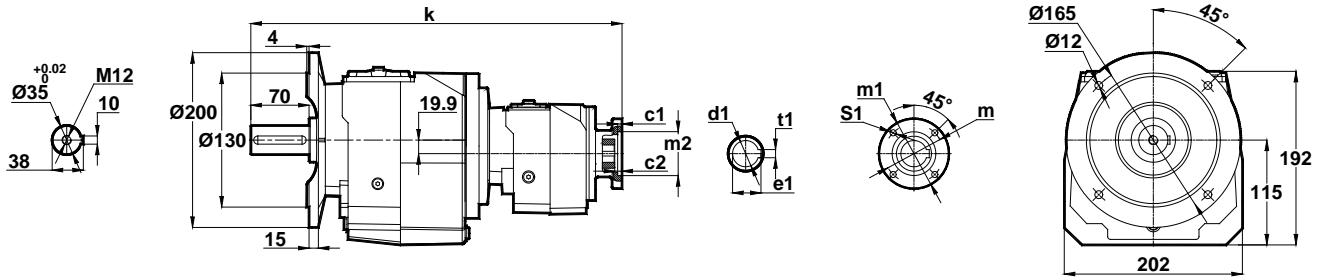

IEC	c1	c2	s1	m	m1	m2	i1	u	k	d1	t1	e1
63/B14	2.5	5	5.5	75	90	60	177.5	10	439	11	4	12.8
71/B14	3	4.5	7	85	105	70	179	10	441	14	5	16.3

Opsiyonel Flanş Ölçüleri / Optional Flange Dimensions / Auswählbare Flanschabmessungen

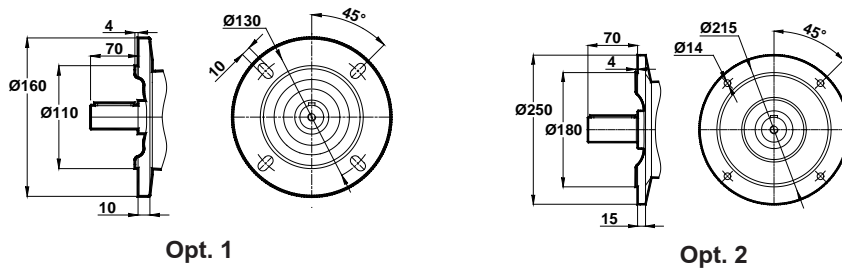

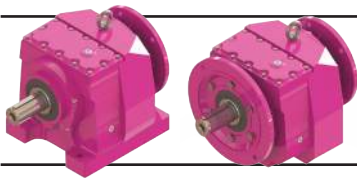

Ölçü Sayfaları Dimension Pages Abmessungsseiten



-Mil ucu çektirme deliği DIN 332 sayfa 2 / Tapped center hole to DIN 332, sheet 2 / Zentrierung mit gewinde DIN 332, Blatt 2

MN282-A.. MN283-A..

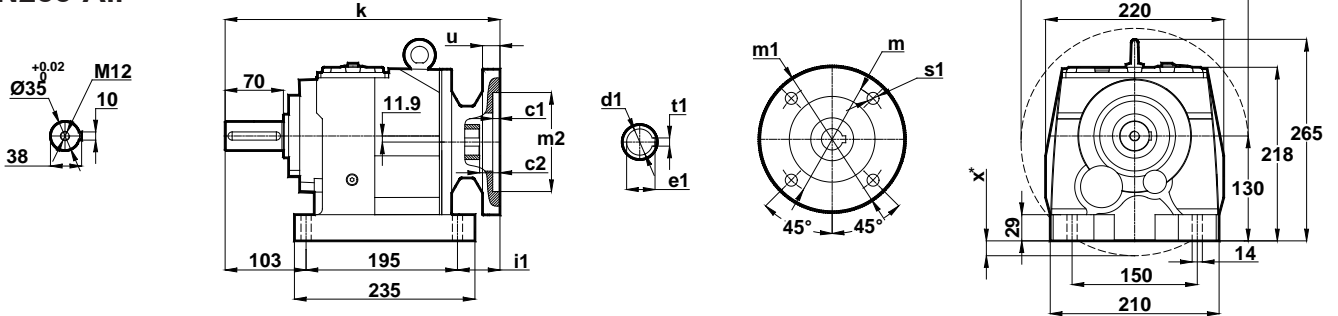

NN282-A.. NN283-A..

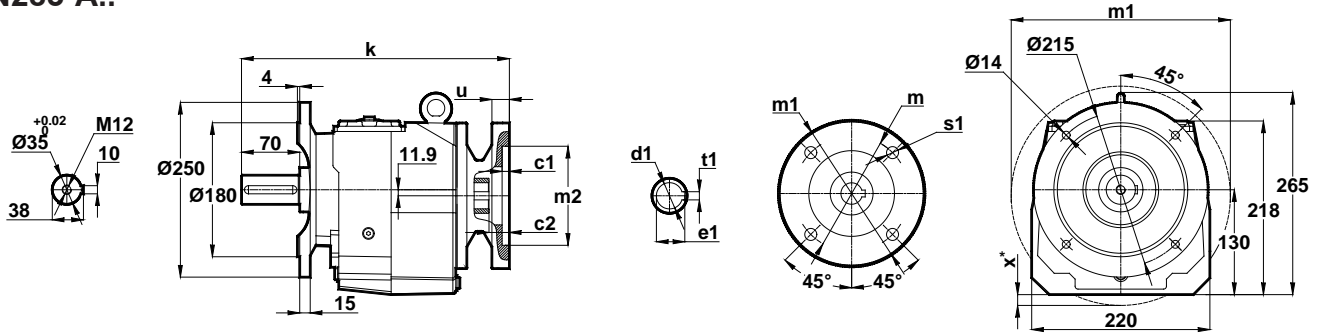

IEC	c1	c2	s1	m	m1	m2	i1	u	k	d1	t1	e1	x
71/B5	4	9	11	130	160	110	45	12	343	14	5	16.3	-
80/B5	4	9	12	165	200	130	45	12	343	19	6	21.8	-
90/B5	4	9	12	165	200	130	45	12	343	24	8	27.3	-
100/B5	4.5	9	15	215	250	180	52	15	350	28	8	31.3	7
112/B5	4.5	9	15	215	250	180	52	15	350	28	8	31.3	7
132/B5	4.5	7	15	265	300	230	82	15	380	38	10	41.3	32

Opsiyonel Flanş Ölçüleri / Optional Flange Dimensions / Auswählbare Flanschabmessungen

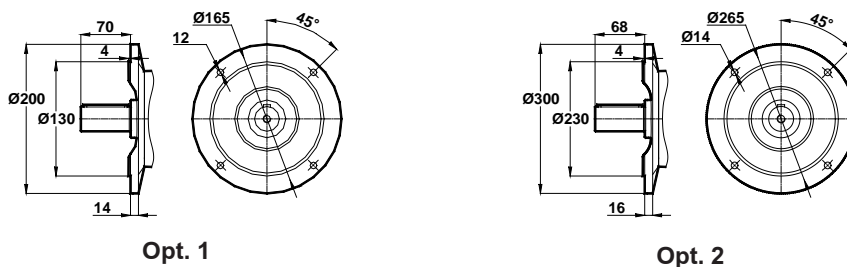

x: Motor flanş, ayak bağlantı yüzeyinin altında ise / x: If Motor flange is lower then foot mounting plane / x: Wenn motorflansch ist niedriger den die Anschlußplatte

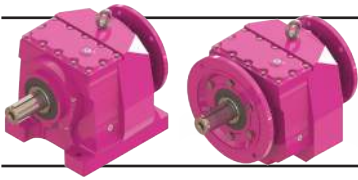

Ölçü Sayfaları

Dimension Pages

Abmessungsseiten



-Mil ucu çektirme deliği DIN 332 sayfa 2 / Tapped center hole to DIN 332, sheet 2 / Zentrierung mit gewinde DIN 332, Blatt 2

MN282-B.. MN283-B..

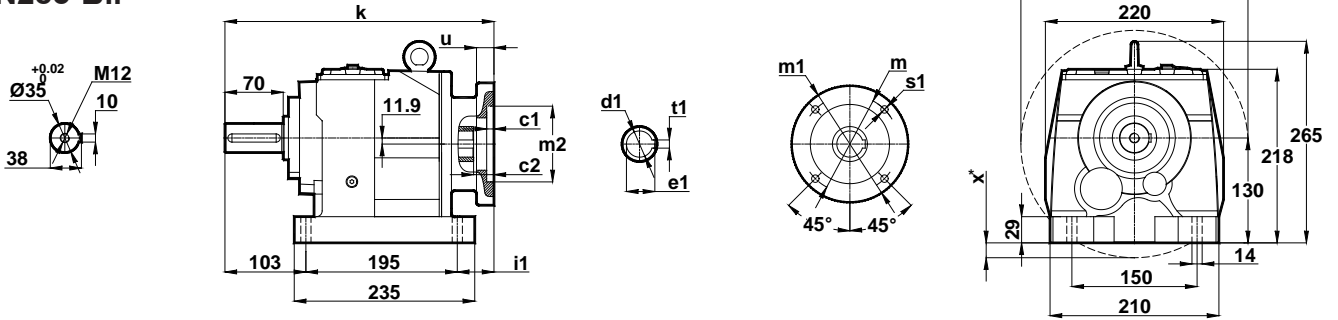

NN282-B.. NN283-B..

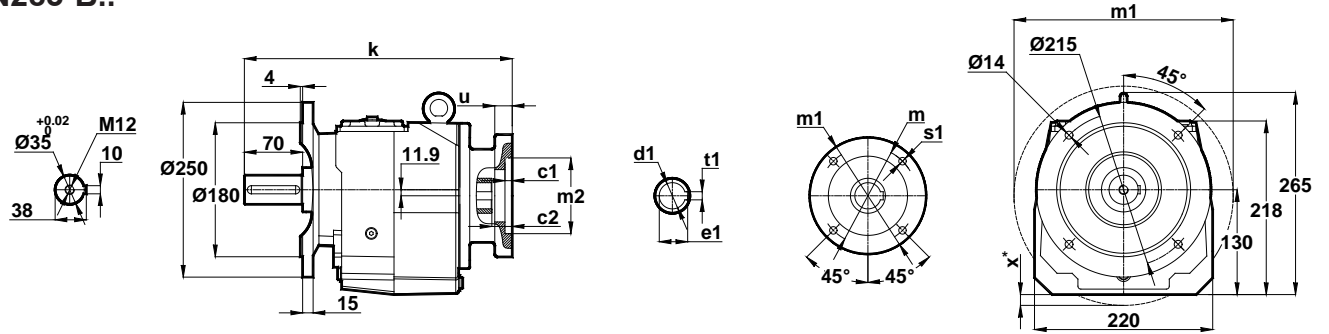

IEC	c1	c2	s1	m	m1	m2	i1	u	k	d1	t1	e1	x
80/B14	4	9	7	100	120	80	45	12	343	19	6	21.8	-
90/B14	4	9	9	115	140	95	45	12	343	24	8	26.3	-
100/B14	4	9	9	130	160	110	52	15	350	28	8	31.3	-
112/B14	4	9	9	130	160	110	52	15	350	28	8	31.3	-
132/B14	4.5	7	11	165	200	130	82	15	380	38	10	41.3	-

Opsiyonel Flanş Ölçüleri / Optional Flange Dimensions / Auswählbare Flanschabmessungen

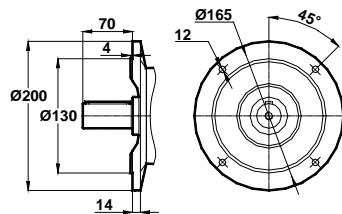

Opt. 1

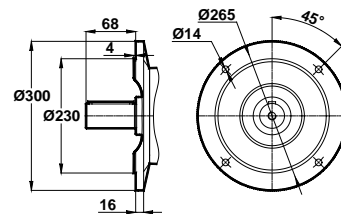

Opt. 2

x: Motor flanşı, ayak bağlantı yüzeyinin altında ise / x: If Motor flange is lower than foot mounting plane / x: Wenn motorflansch ist niedriger den die Anschlußplatte

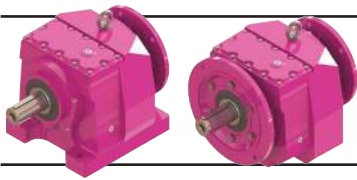

Ölçü Sayfaları Dimension Pages Abmessungenseiten



-Mil ucu çekirme deliği DIN 332 sayfa 2 / Tapped center hole to DIN 332, sheet 2 / Zentrierung mit gewinde DIN 332, Blatt 2

MN284-A.. MN284-B..

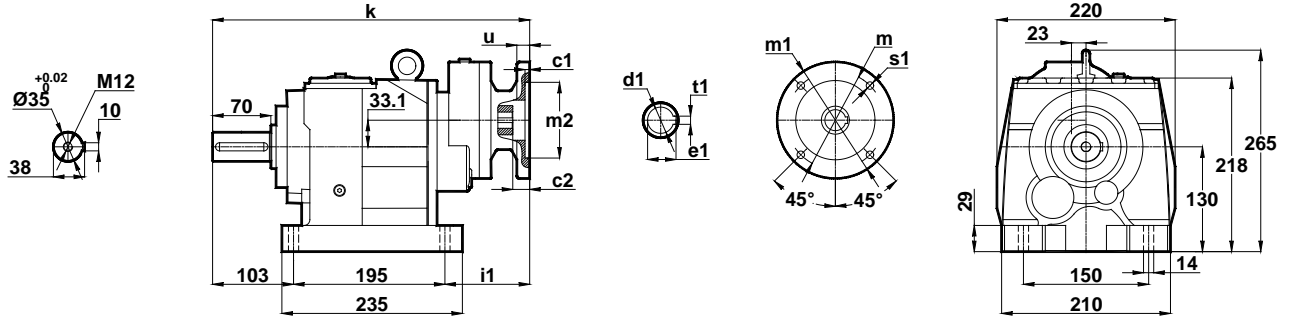

NN284-A.. NN284-B..

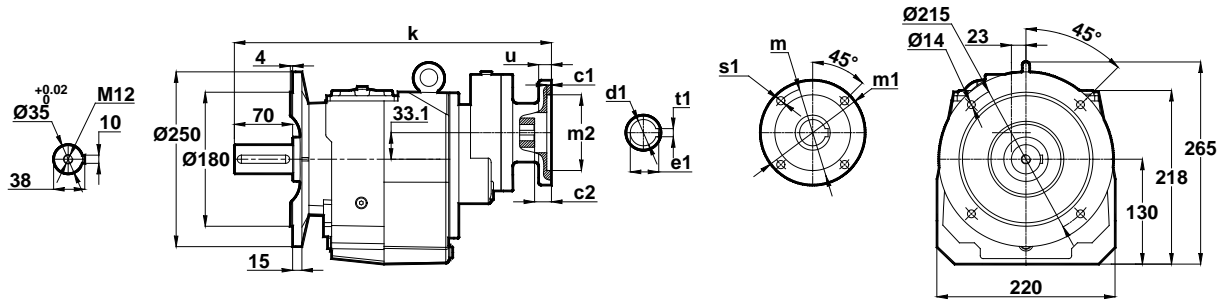

IEC	c1	c2	s1	m	m1	m2	i1	u	k	d1	t1	e1
63/B5	3.5	5	10	115	140	95	122	10	420	11	4	12.8
71/B5	4	4.5	11	130	160	110	93	12	391	14	5	16.3
71/B14	3	4.5	7	85	105	70	93	10	391	14	5	16.3

Opsiyonel Flanş Ölçüleri / Optional Flange Dimensions / Auswählbare Flanschabmessungen

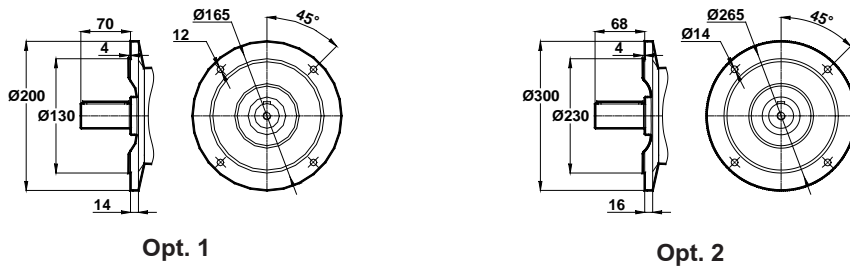

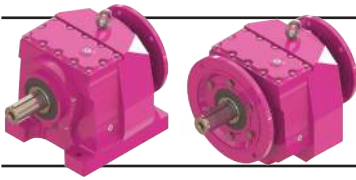

Ölçü Sayfaları Dimension Pages Abmessungsseiten



-Mil ucu çektirme deliği DIN 332 sayfa 2 / Tapped center hole to DIN 332, sheet 2 / Zentrierung mit gewinde DIN 332, Blatt 2

MN285-A.. / B..
MN286-A.. / B..

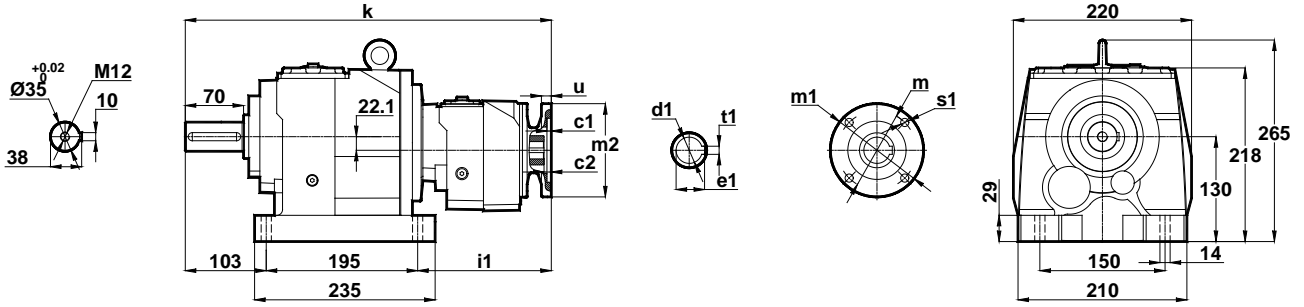

NN285-A.. / B..
NN286-A.. / B..

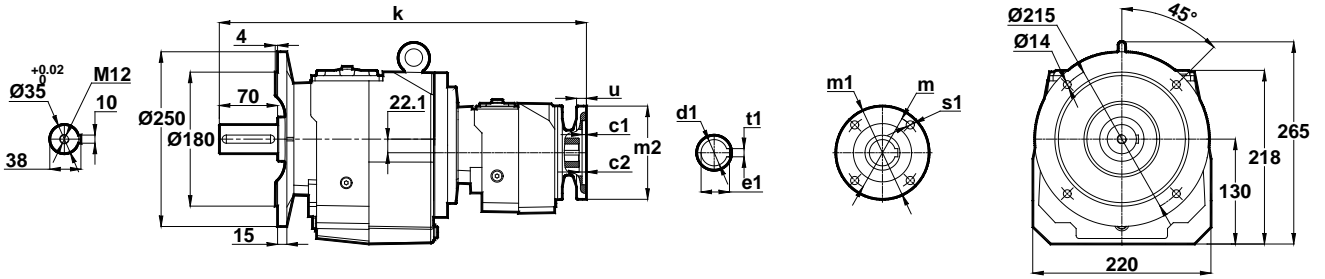

IEC	c1	c2	s1	m	m1	m2	i1	u	k	d1	t1	e1
63/B5	4	7	10	115	140	95	188	12	486	11	4	12.8
63/B14	2.5	5	5.5	75	90	60	188	10	486	11	4	12.8

Opsiyonel Flanş Ölçüleri / Optional Flange Dimensions / Auswählbare Flanschabmessungen

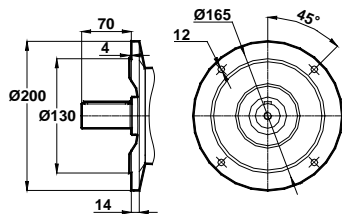

Opt. 1

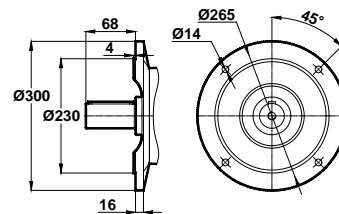

Opt. 2

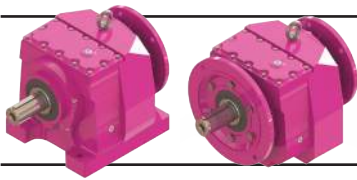

Ölçü Sayfaları Dimension Pages Abmessungsseiten



-Mil ucu çektirme deliği DIN 332 sayfa 2 / Tapped center hole to DIN 332, sheet 2 / Zentrierung mit gewinde DIN 332, Blatt 2

MN372-A.. MN373-A..

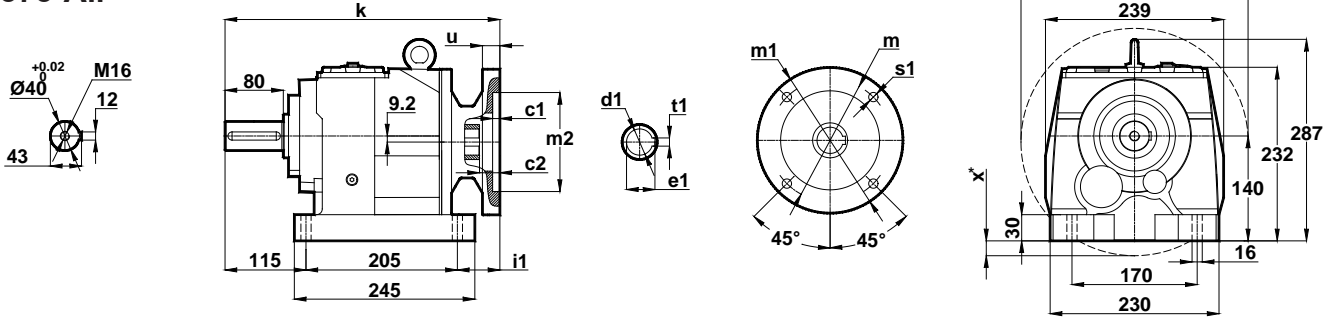

NN372-A.. NN373-A..

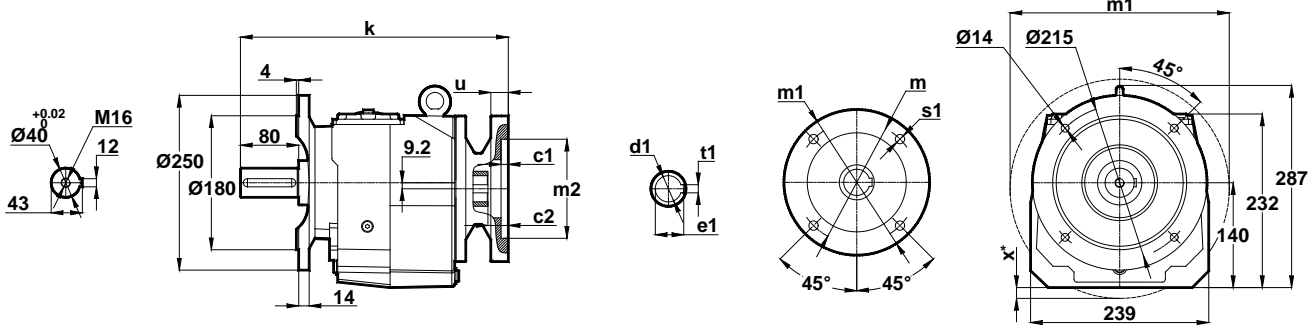

IEC	c1	c2	s1	m	m1	m2	i1	u	k	d1	t1	e1	x
71/B5	4	9	11	130	160	110	43.5	12	364	14	5	16.3	-
80/B5	4	9	12	165	200	130	43.5	12	364	19	6	21.8	-
90/B5	4	9	12	165	200	130	43.5	12	364	24	8	27.3	-
100/B5	4.5	9	15	215	250	180	60.5	15	381	28	8	31.3	-
112/B5	4.5	9	15	215	250	180	60.5	15	381	28	8	31.3	-
132/B5	4.5	7	15	265	300	230	80.5	15	401	38	10	41.3	20

Opsiyonel Flanş Ölçüleri / Optional Flange Dimensions / Auswählbare Flanschabmessungen

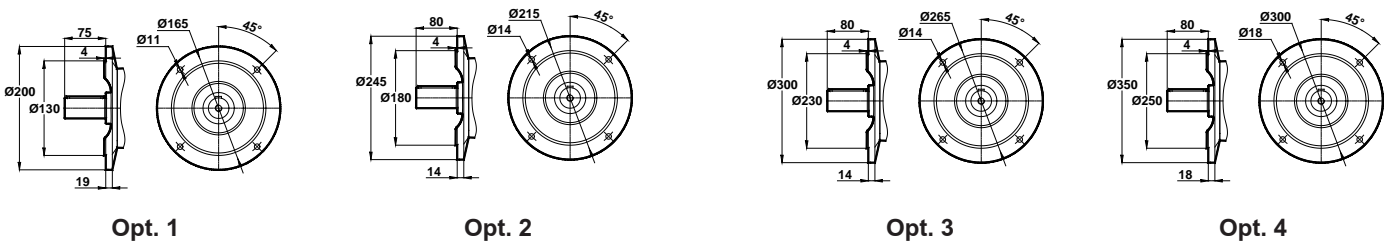

x: Motor flanş, ayak bağlantı yüzeyinin altında ise / x: If Motor flange is lower then foot mounting plane / x: Wenn motorflansch ist niedriger den die Anschlussplatte

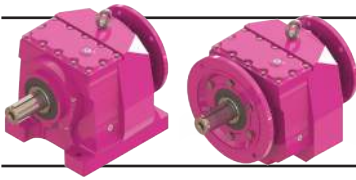

Ölçü Sayfaları

Dimension Pages

Abmessungsseiten



-Mil ucu çektirme deliği DIN 332 sayfa 2 / Tapped center hole to DIN 332, sheet 2 / Zentrierung mit gewinde DIN 332, Blatt 2

MN372-B.. MN373-B..

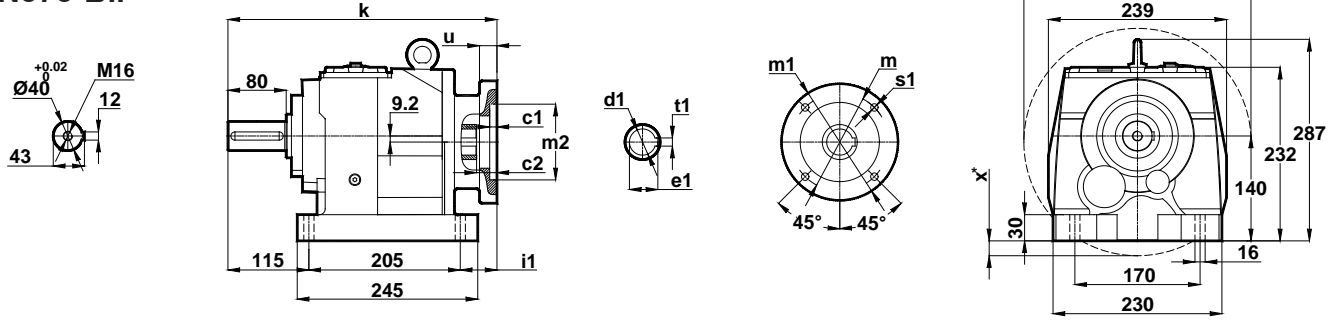

NN372-B.. NN373-B..

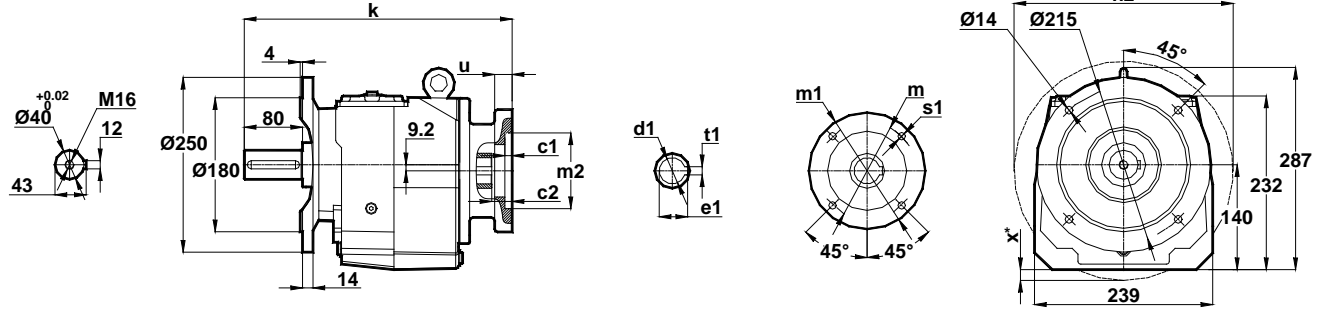

IEC	c1	c2	s1	m	m1	m2	i1	u	k	d1	t1	e1	x
80/B14	4	9	7	100	120	80	43.5	12	364	19	6	21.8	-
90/B14	4	9	9	115	140	95	43.5	12	364	24	8	27.3	-
100/B14	4	9	9	130	160	110	60.5	15	381	28	8	31.3	-
112/B14	4	9	9	130	160	110	60.5	15	381	28	8	31.3	-
132/B14	4.5	9	11	165	200	130	80.5	15	401	38	10	41.3	-

Opsiyonel Flanş Ölçüleri / Optional Flange Dimensions / Auswählbare Flanschabmessungen

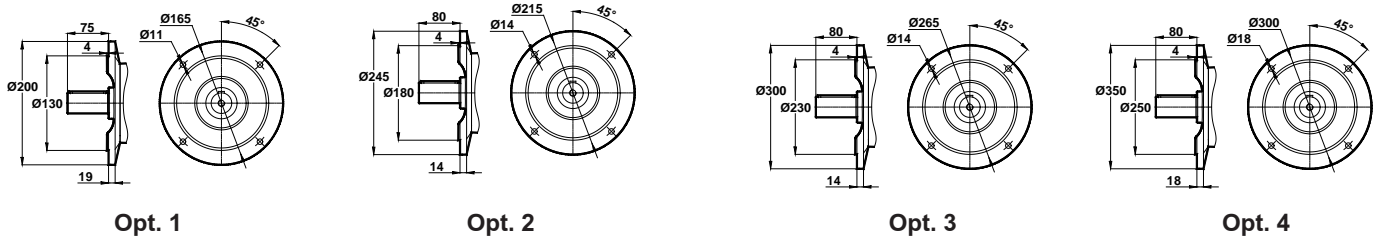

x: Motor flanşı, ayak bağlantı yüzeyinin altında ise / x: If Motor flange is lower then foot mounting plane / x: Wenn motorflansch ist niedriger den die Anschlußplatte

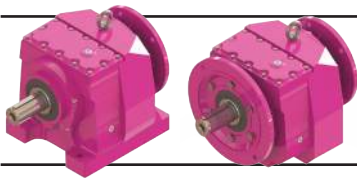

Ölçü Sayfaları Dimension Pages Abmessungsseiten



-Mil ucu çektirme deliği DIN 332 sayfa 2 / Tapped center hole to DIN 332, sheet 2 / Zentrierung mit gewinde DIN 332, Blatt 2

MN374-A.. MN374-B..

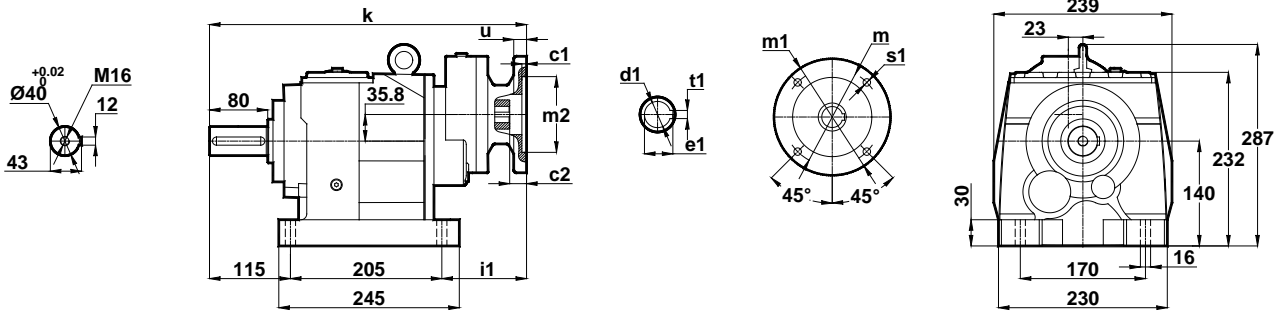

NN374-A.. NN374-B..

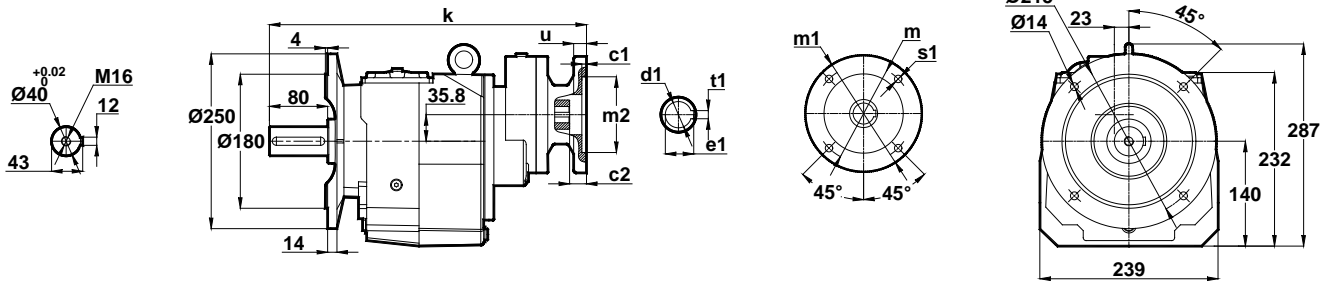

IEC	c1	c2	s1	m	m1	m2	i1	u	k	d1	t1	e1
63/B5	4	5	9	115	140	95	120.5	12	441	11	4	12.8
71/B5	4	8.5	11	130	160	110	91.5	12	412	14	5	16.3
80/B5	4	5	12	165	200	130	120.5	12	441	19	6	21.8
71/B14	3	8.5	7	85	105	70	91.5	10	412	14	5	16.3
80/B14	4	5	7	100	120	80	120.5	12	441	19	6	21.8

Opsiyonel Flanş Ölçüleri / Optional Flange Dimensions / Auswählbare Flanschabmessungen

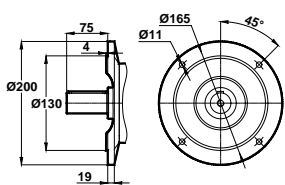

Opt. 1

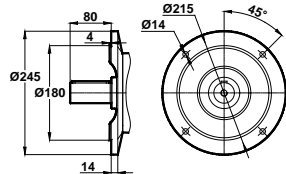

Opt. 2

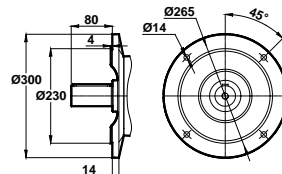

Opt. 3

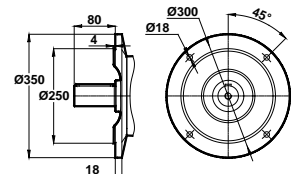

Opt. 4

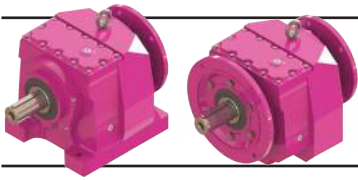

Ölçü Sayfaları

Dimension Pages

Abmessungsseiten



-Mil ucu çektirme deliği DIN 332 sayfa 2 / Tapped center hole to DIN 332, sheet 2 / Zentrierung mit gewinde DIN 332, Blatt 2

MN375-A.. / B.. MN376-A.. / B..

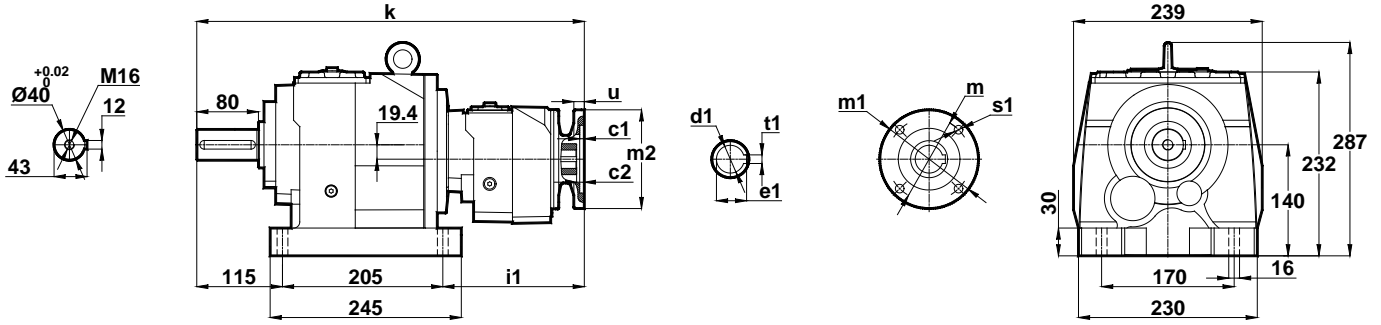

NN375-A.. / B.. NN376-A.. / B..

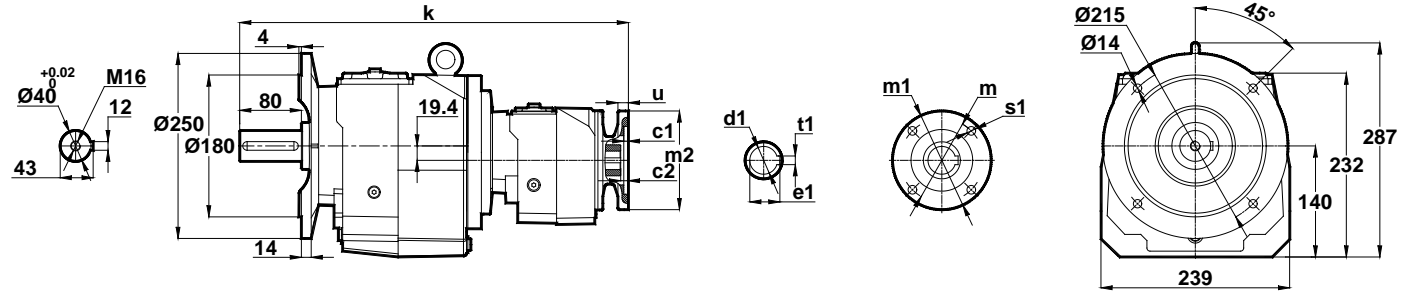

IEC	c1	c2	s1	m	m1	m2	i1	u	k	d1	t1	e1
63/B5	3.5	5	10	115	140	95	186.5	10	507	11	4	12.8
63/B14	2.5	5	5.5	75	90	60	186.5	10	507	11	4	12.8

Opsiyonel Flanş Ölçüleri / Optional Flange Dimensions / Auswählbare Flanschabmessungen

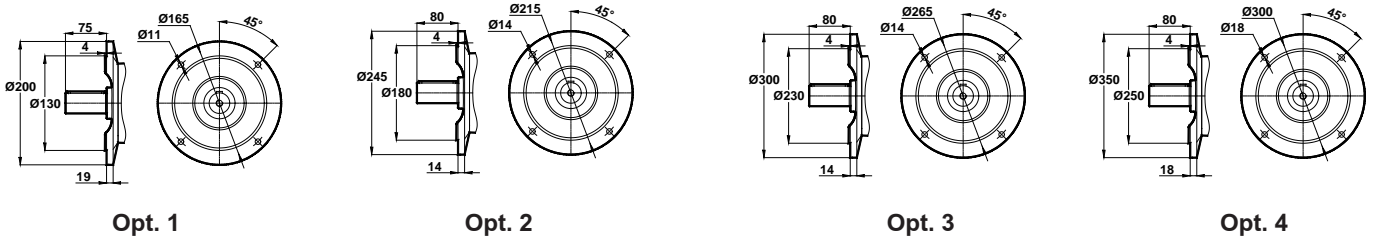

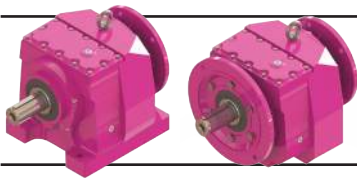

Ölçü Sayfaları Dimension Pages Abmessungsseiten



-Mil ucu çektirme deliği DIN 332 sayfa 2 / Tapped center hole to DIN 332, sheet 2 / Zentrierung mit gewinde DIN 332, Blatt 2

MN472-A.. MN473-A..

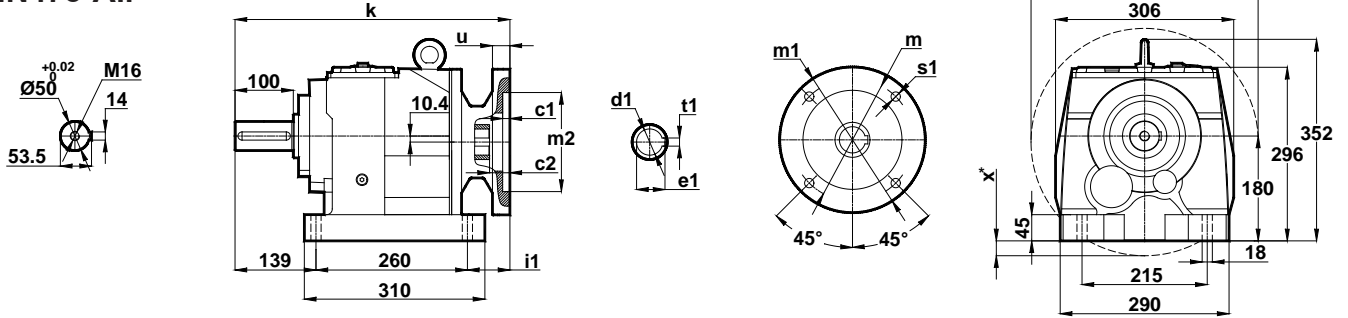

NN472-A.. NN473-A..

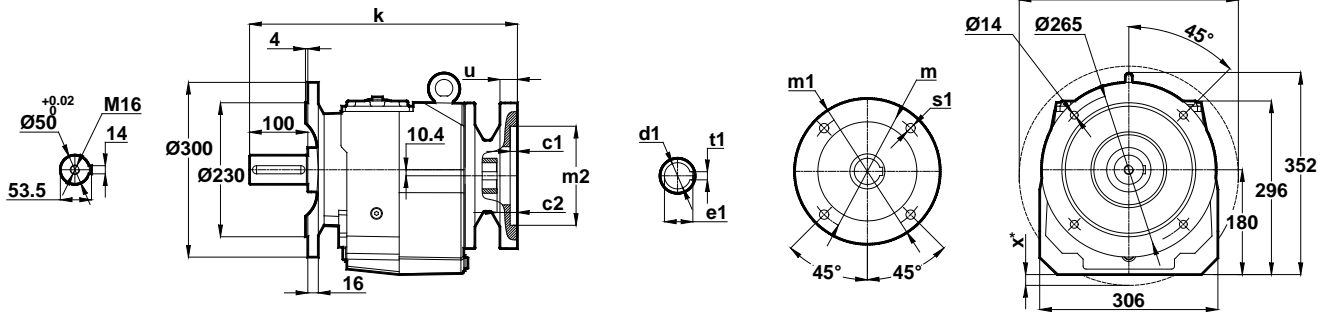

IEC	c1	c2	s1	m	m1	m2	i1	u	k	d1	t1	e1	x
80/B5	4	5	12	165	200	130	27.5	12	427	19	6	21.8	-
90/B5	4	5	12	165	200	130	27.5	12	427	24	8	27.3	-
100/B5	4.5	9	15	215	250	180	46	15	445	28	8	31.3	-
112/B5	4.5	9	15	215	250	180	46	15	445	28	8	31.3	-
132/B5	4.5	6	15	265	300	230	64.5	15	464	38	10	41.3	-
160/B5	5.5	10	19	300	350	250	144	20	543	42	12	45.3	6
180/B5	5.5	10	19	300	350	250	144	20	543	48	14	51.8	6

Opsiyonel Flanş Ölçüleri / Optional Flange Dimensions / Auswählbare Flanschabmessungen

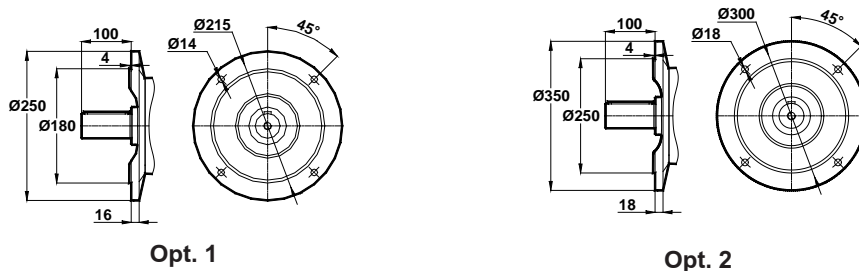

x: Motor flanş, ayak bağlantı yüzeyinin altında ise / x: If Motor flange is lower then foot mounting plane / x: Wenn motorflansch ist niedriger den die Anschlußplatte

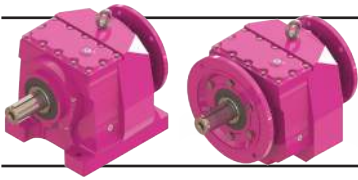

Ölçü Sayfaları

Dimension Pages

Abmessungsseiten



-Mil ucu çektirme deliği DIN 332 sayfa 2 / Tapped center hole to DIN 332, sheet 2 / Zentrierung mit gewinde DIN 332, Blatt 2

MN472-B..
MN473-B..

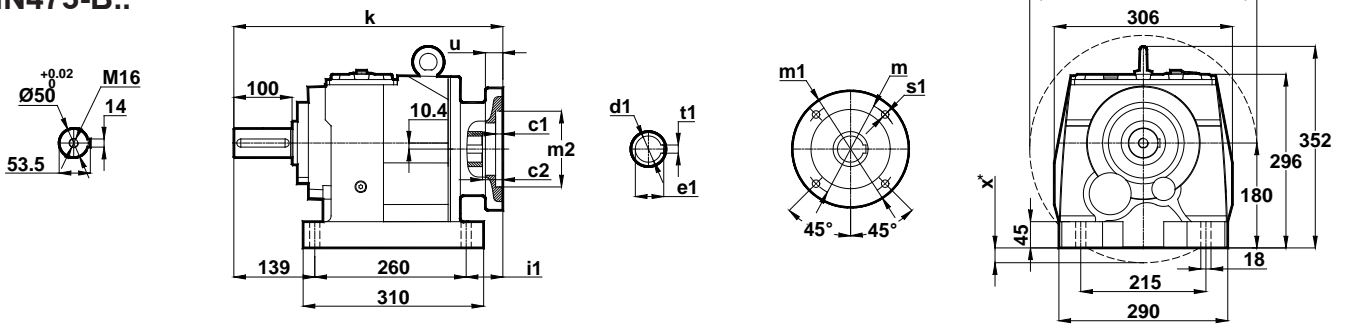

NN472-B..
NN473-B..

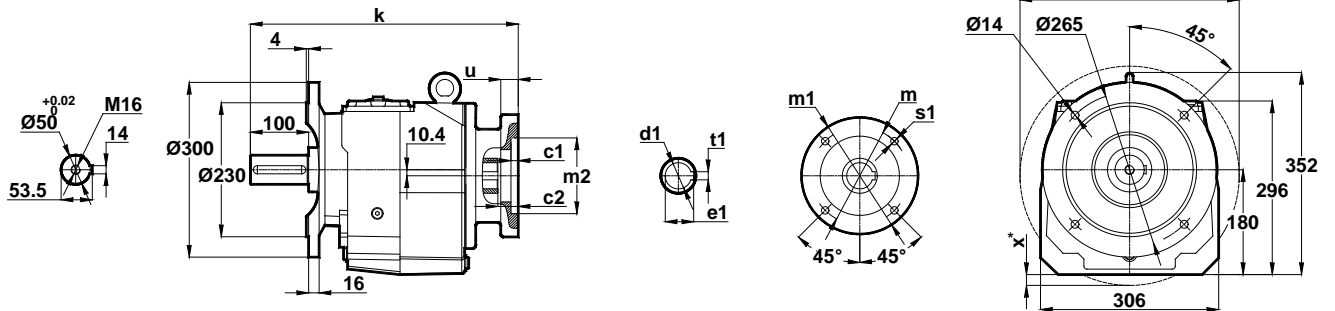

IEC	c1	c2	s1	m	m1	m2	i1	u	k	d1	t1	e1	x
90/B14	4	5	9	115	140	95	27.5	12	427	24	8	27.3	-
100/B14	4	9	9	130	160	110	46	15	445	28	8	31.3	-
112/B14	4	9	9	130	160	110	46	15	445	28	8	31.3	-
132/B14	4.4	6	11	165	200	130	64.5	15	464	38	10	41.3	-

Opsiyonel Flanş Ölçüleri / Optional Flange Dimensions / Auswählbare Flanschabmessungen

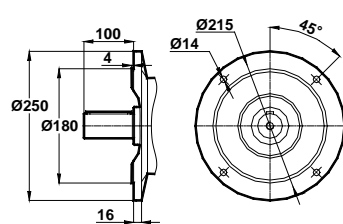

Opt. 1

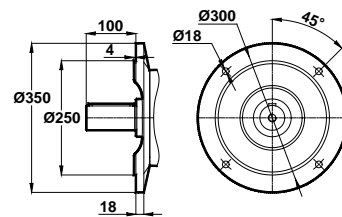

Opt. 2

x: Motor flanşı, ayak bağlantı yüzeyinin altında ise / x: If Motor flange is lower than foot mounting plane / x: Wenn motorflansch ist niedriger den die Anschlußplatte

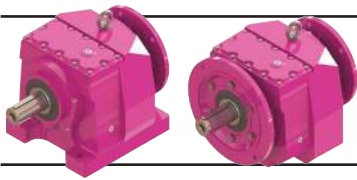

Ölçü Sayfaları

Dimension Pages

Abmessungsseiten



-Mil ucu çekirme deliği DIN 332 sayfa 2 / Tapped center hole to DIN 332, sheet 2 / Zentrierung mit gewinde DIN 332, Blatt 2

MN474-A.. MN474-B..

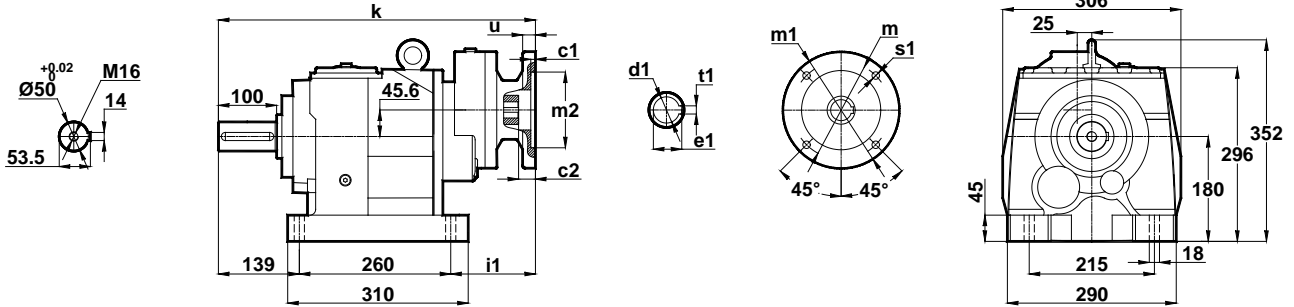

NN474-A.. NN474-B..

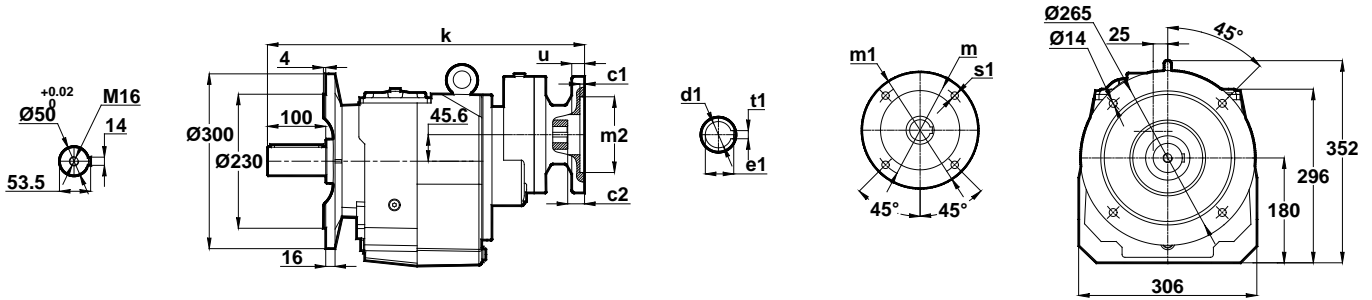

IEC	c1	c2	s1	m	m1	m2	i1	u	k	d1	t1	e1
71/B5	4	9	11	130	160	110	125.5	12	525	14	5	16.3
80/B5	4	9	12	165	200	130	125.5	12	525	19	6	21.8
80/B14	4	9	7	100	120	80	125.5	12	525	19	6	21.8

Opsiyonel Flanş Ölçüleri / Optional Flange Dimensions / Auswählbare Flanschabmessungen

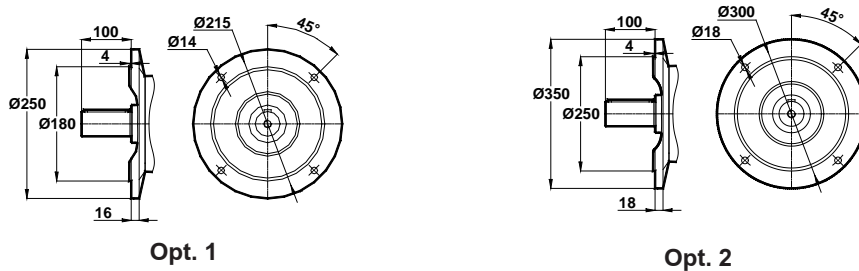

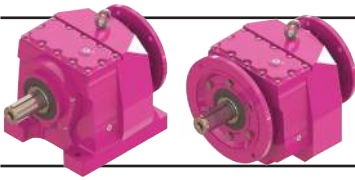

Ölçü Sayfaları

Dimension Pages

Abmessungsseiten



-Mil ucu çektirme deliği DIN 332 sayfa 2 / Tapped center hole to DIN 332, sheet 2 / Zentrierung mit gewinde DIN 332, Blatt 2

MN475-A.. / B..
MN476-A.. / B..

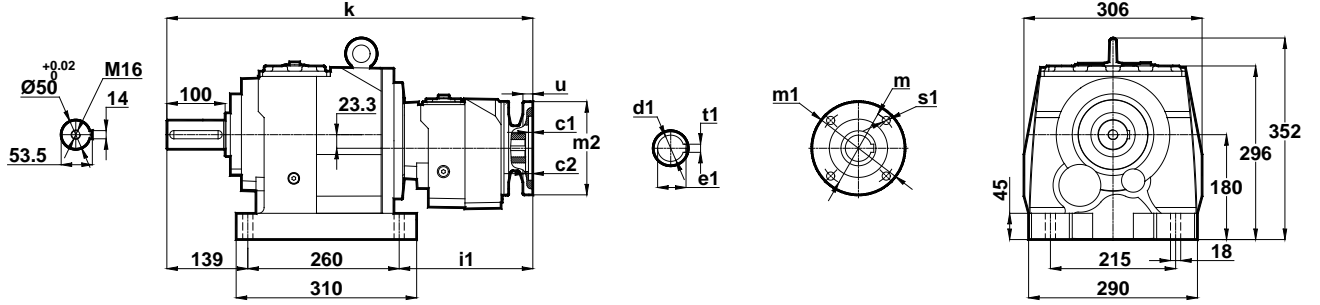

NN475-A.. / B..
NN476-A.. / B..

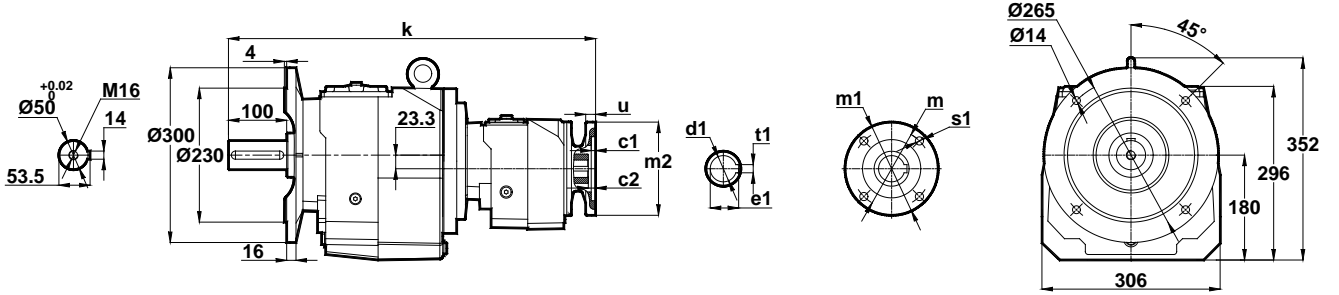

IEC	c1	c2	s1	m	m1	m2	i1	u	k	d1	t1	e1
63/B5	4	5	9	115	140	95	253.5	12	653	11	4	12.8
71/B5	4	8.5	11	130	160	110	224.5	12	624	14	5	16.3
71/B14	3	8.5	7	85	105	70	224.5	10	624	14	5	16.3

Opsiyonel Flanş Ölçüleri / Optional Flange Dimensions / Auswählbare Flanschabmessungen

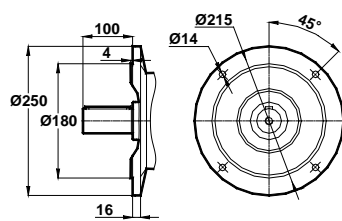

Opt. 1

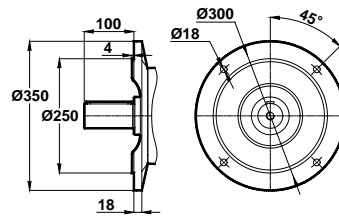

Opt. 2

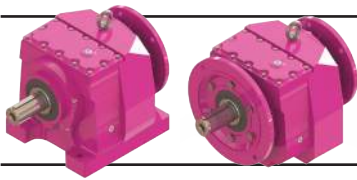

Ölçü Sayfaları Dimension Pages Abmessungsseiten



-Mil ucu çektirme deliği DIN 332 sayfa 2 / Tapped center hole to DIN 332, sheet 2 / Zentrierung mit gewinde DIN 332, Blatt 2

MN572-A.. / B.. MN573-A.. / B..

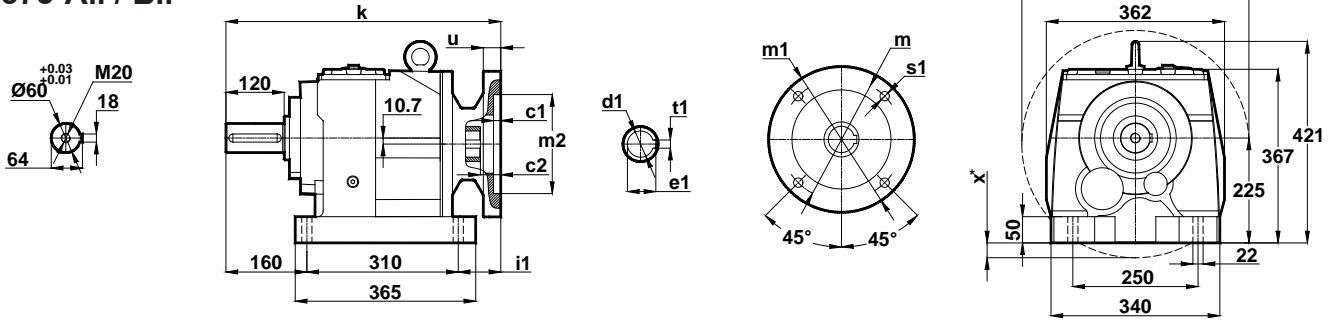

NN572-A.. / B.. NN573-A.. / B..

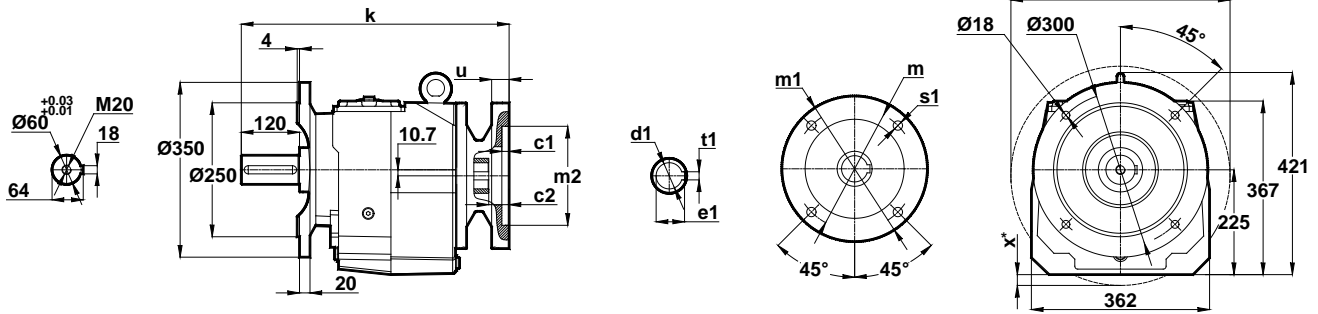

IEC	c1	c2	s1	m	m1	m2	i1	u	k	d1	t1	e1	x
100/B5	4.5	20	15	215	250	180	33.5	15	507	28	8	31.3	-
112/B5	4.5	20	15	215	250	180	33.5	15	507	28	8	31.3	-
132/B5	4.5	9	15	265	300	230	54.5	15	528	38	10	41.3	-
160/B5	5.5	10	19	300	350	250	130	18	603	42	12	45.3	-
180/B5	5.5	10	19	300	350	250	130	18	603	48	14	51.8	-
200/B5	5.5	10	19	350	400	300	150	22	623	55	16	59.3	-
132/B14	4.5	9	11	165	200	130	54.5	15	528	38	10	41.3	-

Opsiyonel Flanş Ölçüleri / Optional Flange Dimensions / Auswählbare Flanschabmessungen

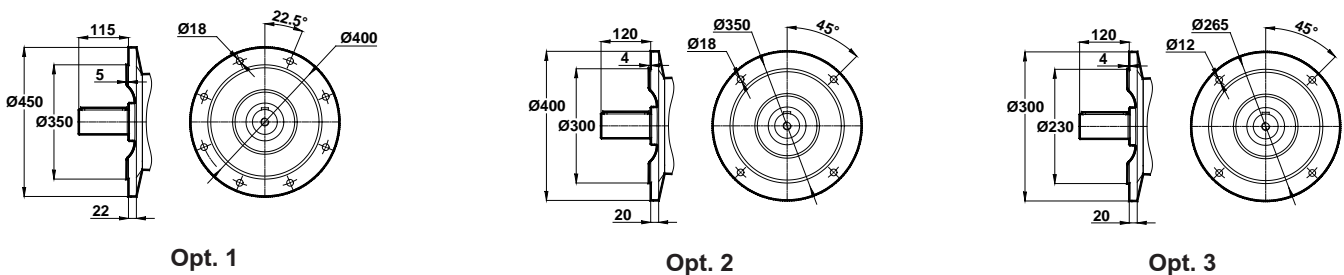

x: Motor flanşı, ayak bağlantı yüzeyinin altında ise / x: If Motor flange is lower then foot mounting plane / x: Wenn motorflansch ist niedriger den die Anschlussplatte

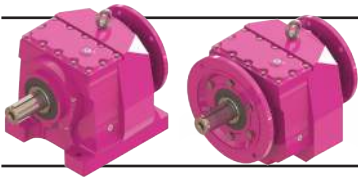

Ölçü Sayfaları

Dimension Pages

Abmessungsseiten



-Mil ucu çektirme deliği DIN 332 sayfa 2 / Tapped center hole to DIN 332, sheet 2 / Zentrierung mit gewinde DIN 332, Blatt 2

MN574-A..

MN574-B..

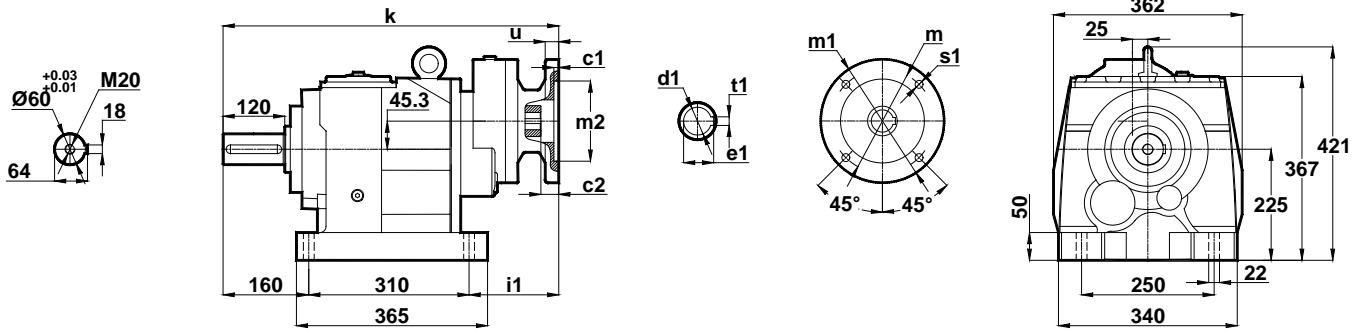

NN574-A..

NN574-B..

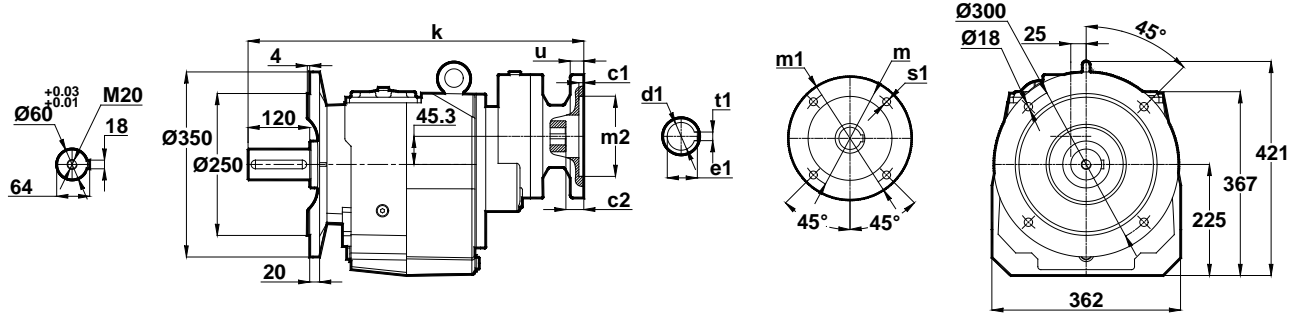

IEC	c1	c2	s1	m	m1	m2	i1	u	k	d1	t1	e1
71/B5	4	9	11	130	160	110	116.5	12	587	14	5	16.3
80/B5	4	9	12	165	200	130	116.5	12	587	14	6	21.8
90/B5	4	9	12	165	200	130	116.5	12	587	19	8	27.3
80/B14	4	9	7	100	120	80	116.5	12	587	19	6	21.8
90/B14	4	9	9	115	140	95	116.5	12	587	24	8	26.3

Opsiyonel Flanş Ölçüleri / Optional Flange Dimensions / Auswählbare Flanschabmessungen

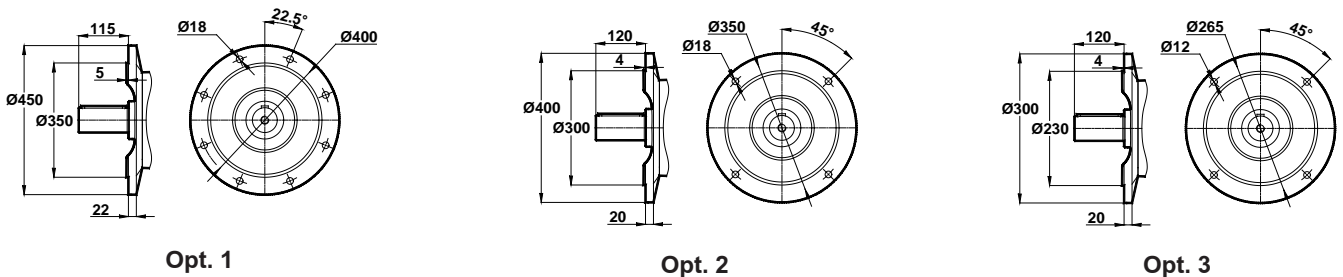

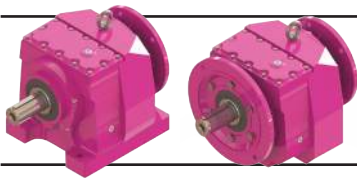

Ölçü Sayfaları Dimension Pages Abmessungsseiten



-Mil ucu çekirme deliği DIN 332 sayfa 2 / Tapped center hole to DIN 332, sheet 2 / Zentrierung mit gewinde DIN 332, Blatt 2

MN575-A.. / B.. MN576-A.. / B..

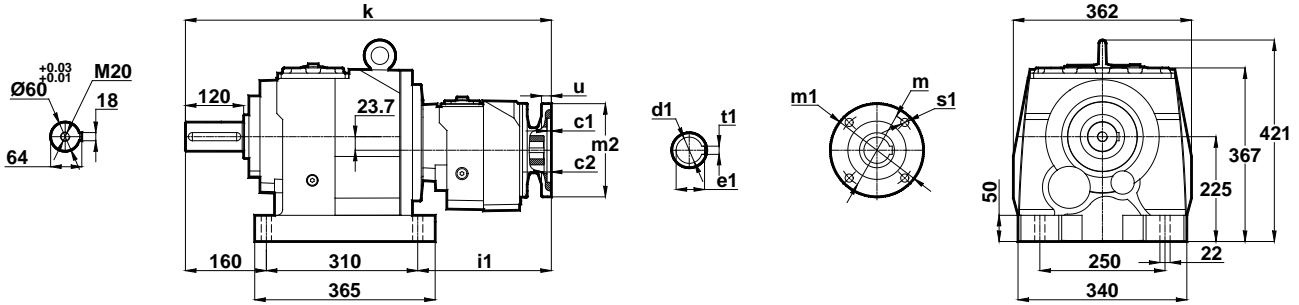

NN575-A.. / B.. NN576-A.. / B..

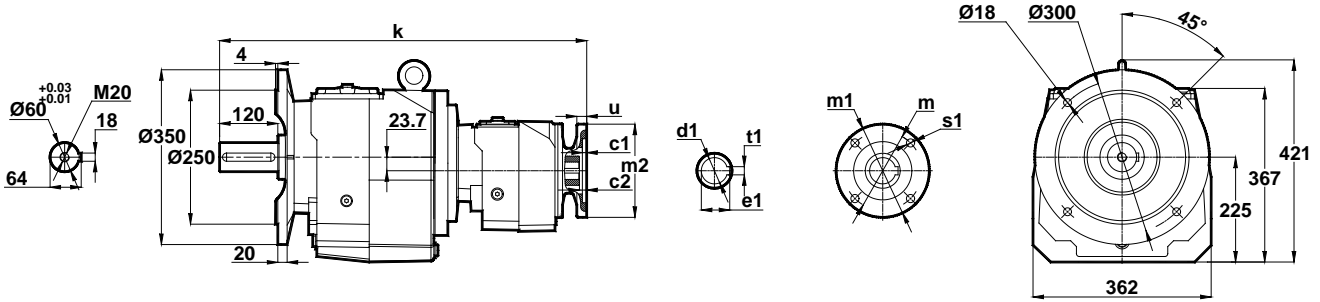

IEC	c1	c2	s1	m	m1	m2	i1	u	k	d1	t1	e1
63/B5	4	5	9	115	140	95	246.5	12	717	11	4	12.8
71/B5	4	8.5	11	130	160	110	217.5	12	688	14	5	16.3
71/B14	3	8.5	7	85	105	70	217.5	10	688	14	5	16.3

Opsiyonel Flanş Ölçüleri / Optional Flange Dimensions / Auswählbare Flanschabmessungen

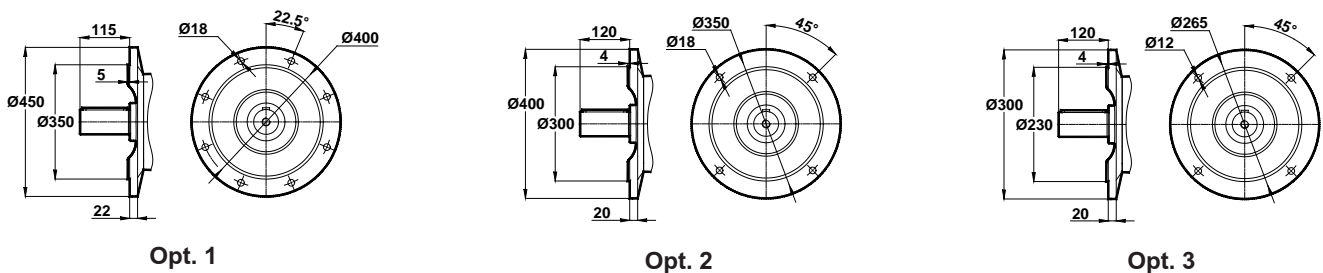

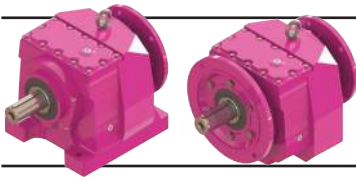

Ölçü Sayfaları Dimension Pages Abmessungsseiten



-Mil ucu çektirme deliği DIN 332 sayfa 2 / Tapped center hole to DIN 332, sheet 2 / Zentrierung mit gewinde DIN 332, Blatt 2

MN672-A.. / B.. MN673-A.. / B..

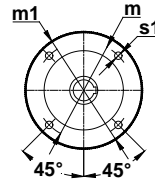
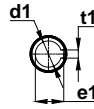
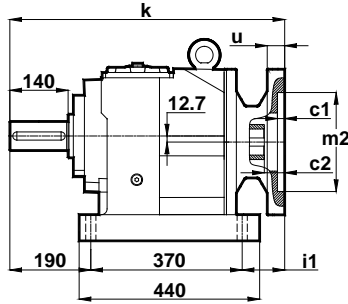
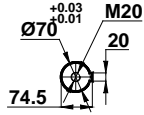

112 - 200 Tip / Type / Typ

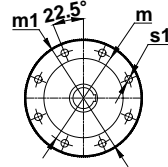

225 Tip / Type / Typ

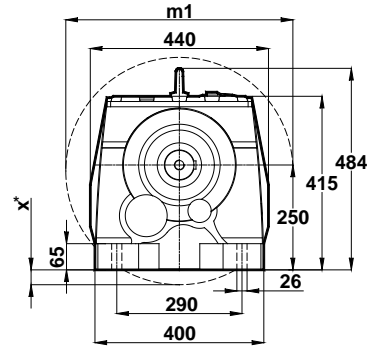

NN672-A.. / B.. NN673-A.. / B..

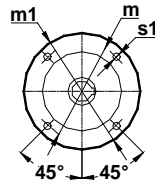
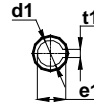
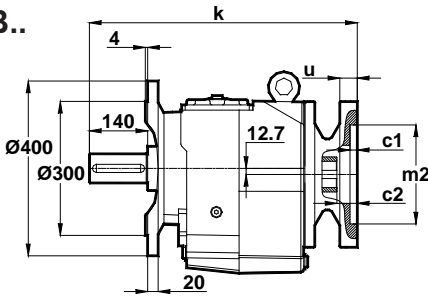
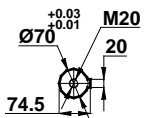

112 - 200 Tip / Type / Typ

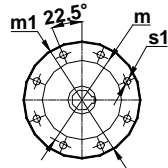

225 Tip / Type / Typ

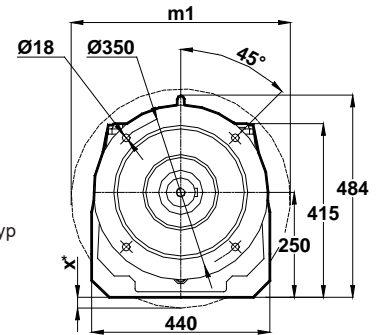

IEC	c1	c2	s1	m	m1	m2	i1	u	k	d1	t1	e1	x
112/B5	4.5	14.5	15	215	250	180	7.5	15	568	28	8	31.3	-
132/B5	4.5	9	15	265	300	230	22.5	15	583	38	10	41.3	-
160/B5	5.5	10	19	300	350	250	97.5	20	658	42	12	45.3	-
180/B5	5.5	10	19	300	350	250	97.5	20	658	48	14	51.8	-
200/B5	5.5	10	19	350	400	300	118	22	678	55	16	59.3	-
225/B5	5.5	10	19	400	450	350	171	24	731	60	18	64.4	-
132/B14	4.5	9	15	165	200	130	22.5	15	583	38	10	41.3	-

Opsiyonel Flanş Ölçüleri / Optional Flange Dimensions / Auswählbare Flanschabmessungen

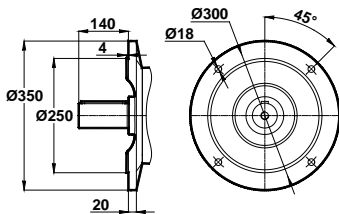

Opt. 1

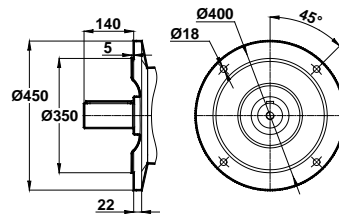

Opt. 2

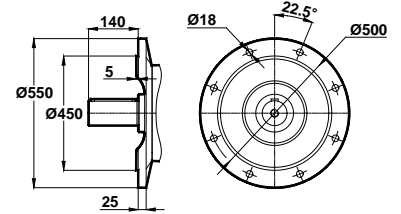

Opt. 3

x: Motor flanşı, ayak bağlantı yüzeyinin altında ise / x: If Motor flange is lower then foot mounting plane / x: Wenn motorflansch ist niedriger den die Anschlußplatte

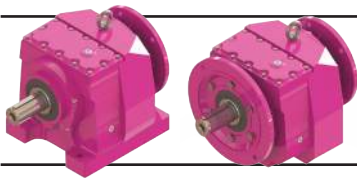

Ölçü Sayfaları

Dimension Pages

Abmessungsseiten



-Mil ucu çekirme deliği DIN 332 sayfa 2 / Tapped center hole to DIN 332, sheet 2 / Zentrierung mit gewinde DIN 332, Blatt 2

MN674-A.. MN674-B..

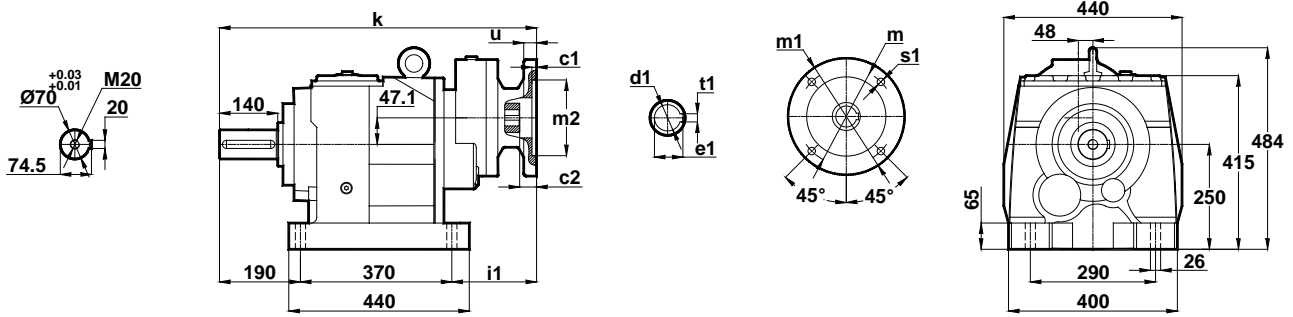

NN674-A.. NN674-B..

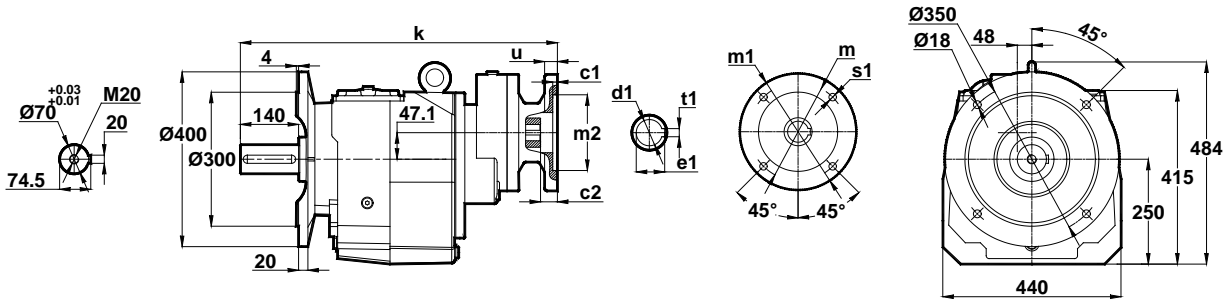

IEC	c1	c2	s1	m	m1	m2	i1	u	k	d1	t1	e1
80/B5	4	5	12	165	200	130	97.5	12	658	19	6	21.8
90/B5	4	5	12	165	200	130	97.5	12	658	24	8	27.3
90/B14	4	5	9	115	140	95	97.5	12	658	24	8	27.3

Opsiyonel Flanş Ölçüleri / Optional Flange Dimensions / Auswählbare Flanschabmessungen

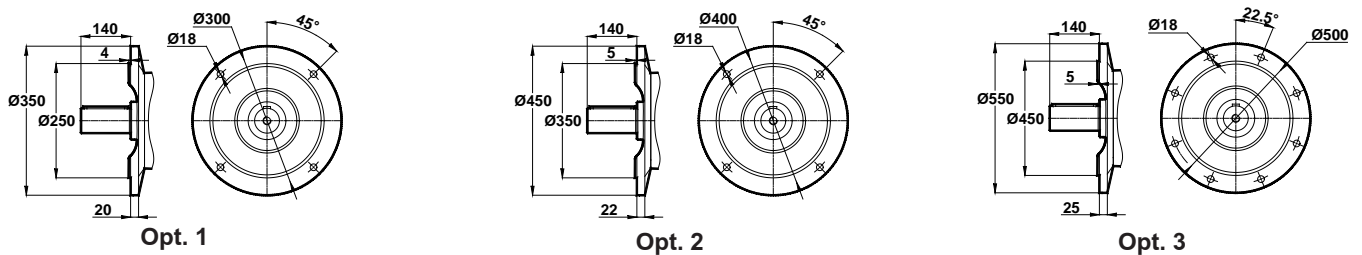

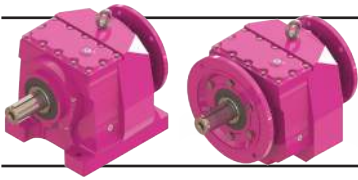

Ölçü Sayfaları

Dimension Pages

Abmessungsseiten



-Mil ucu çektirme deliği DIN 332 sayfa 2 / Tapped center hole to DIN 332, sheet 2 / Zentrierung mit gewinde DIN 332, Blatt 2

MN675-A.. / B.. MN676-A.. / B..

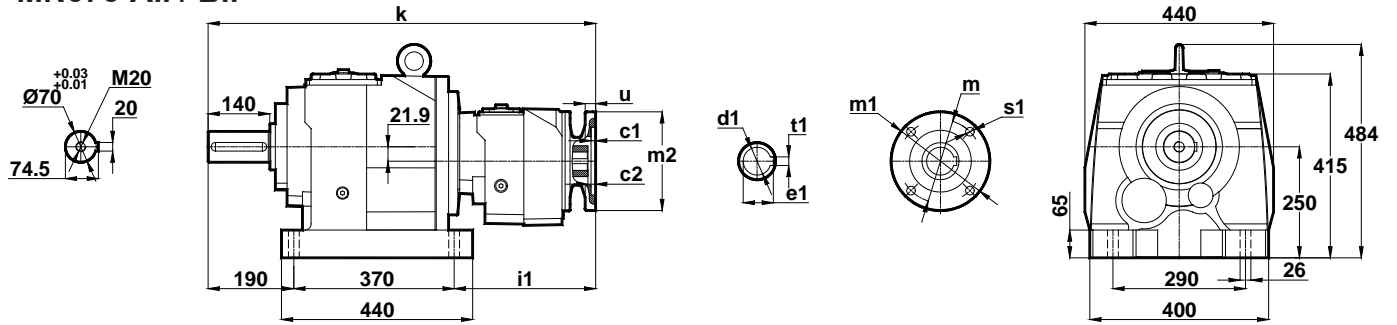

NN675-A.. / B.. NN676-A.. / B..

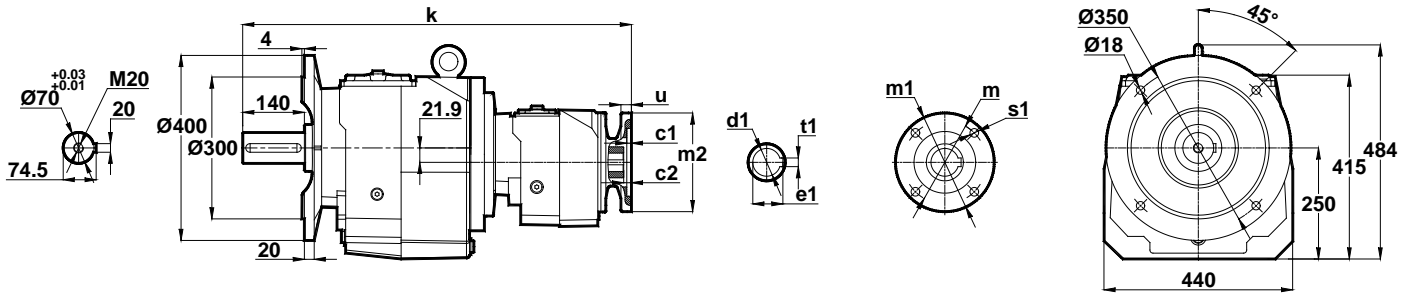

IEC	c1	c2	s1	m	m1	m2	i1	u	k	d1	t1	e1
71/B5	4	9	11	130	160	110	248	12	808	14	5	16.3
80/B5	4	9	12	165	200	130	248	12	808	19	6	21.8
80/B14	4	9	7	100	120	80	248	12	808	19	6	21.8

Opsiyonel Flanş Ölçüleri / Optional Flange Dimensions / Auswählbare Flanschabmessungen

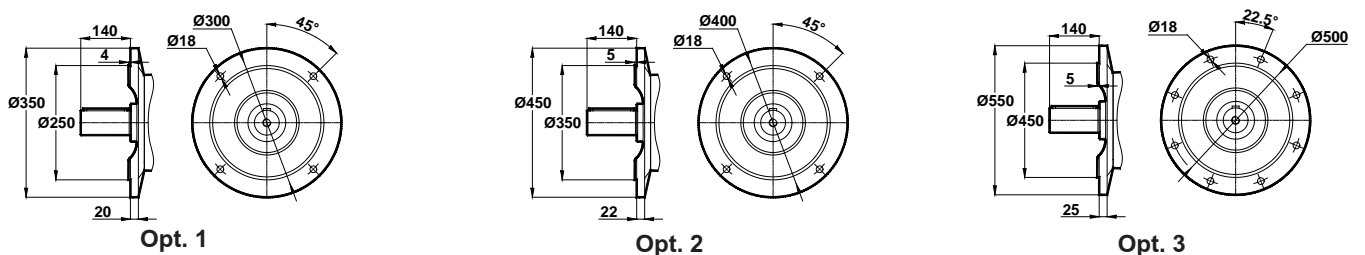

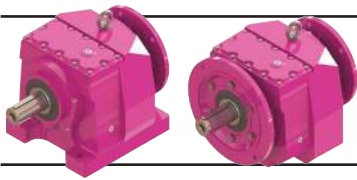

Ölçü Sayfaları Dimension Pages Abmessungsseiten



-Mil ucu çektirme deliği DIN 332 sayfa 2 / Tapped center hole to DIN 332, sheet 2 / Zentrierung mit gewinde DIN 332, Blatt 2

MN772-A.. MN773-A..

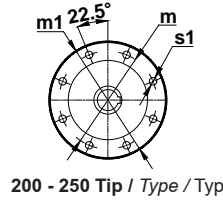
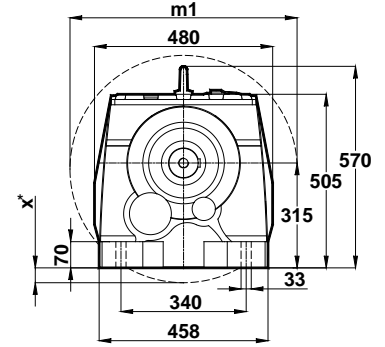
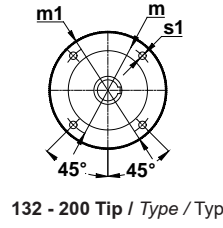
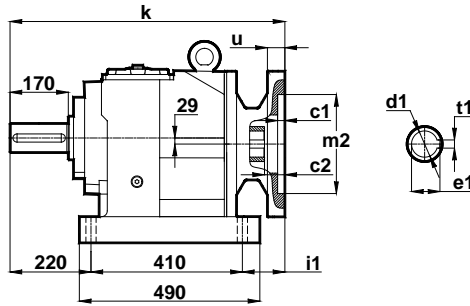
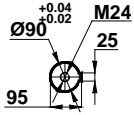

NN772-A.. NN773-A..

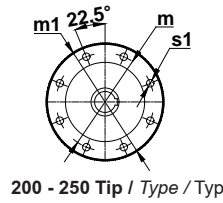
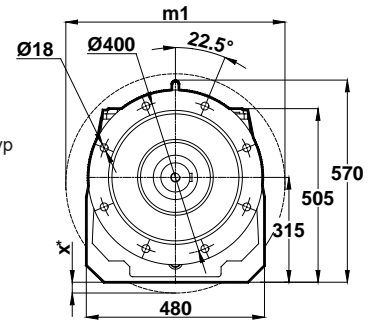
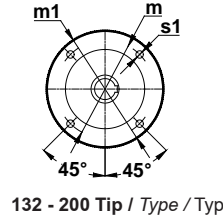
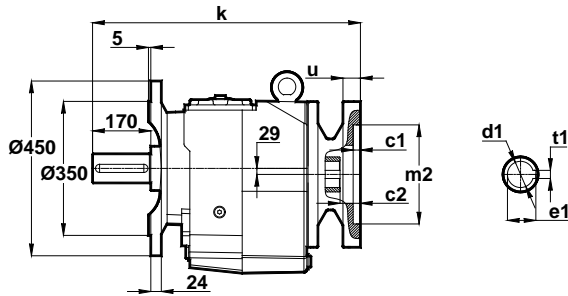
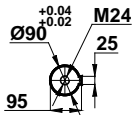

IEC	c1	c2	s1	m	m1	m2	i1	u	k	d1	t1	e1	x
132/B5	4.5	15	15	265	300	230	37.5	15	668	38	10	41.3	-
160/B5	5.5	10	19	300	350	250	107	20	737	42	12	45.3	-
180/B5	5.5	10	19	300	350	250	107	20	737	43	14	51.8	-
200/B5	5.5	10	19	350	400	300	129	20	759	55	16	59.3	-
225/B5	5.5	10	19	400	450	350	182	24	812	60	18	64.4	-
250/B5	5.5	10	19	500	550	450	182	24	812	65	18	69.4	-

Opsiyonel Flanş Ölçüleri / Optional Flange Dimensions / Auswählbare Flanschabmessungen

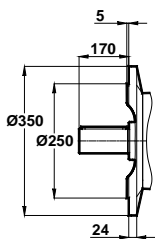

Opt. 1

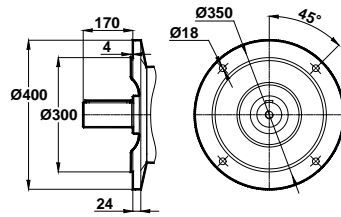
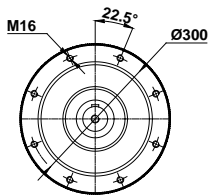

Opt. 2

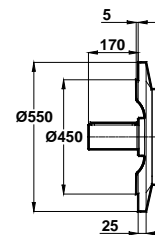
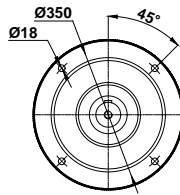

Opt. 3

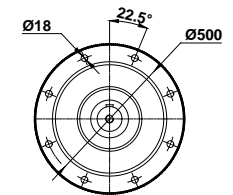

x: Motor flanş, ayak bağlantı yüzeyinin altında ise / x: If Motor flange is lower then foot mounting plane / x: Wenn motorflansch ist niedriger den die Anschlussplatte

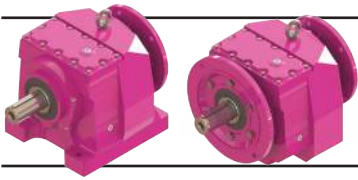

Ölçü Sayfaları

Dimension Pages

Abmessungsseiten



-Mil ucu çektirme deliği DIN 332 sayfa 2 / Tapped center hole to DIN 332, sheet 2 / Zentrierung mit gewinde DIN 332, Blatt 2

MN774-A..

MN774-B..

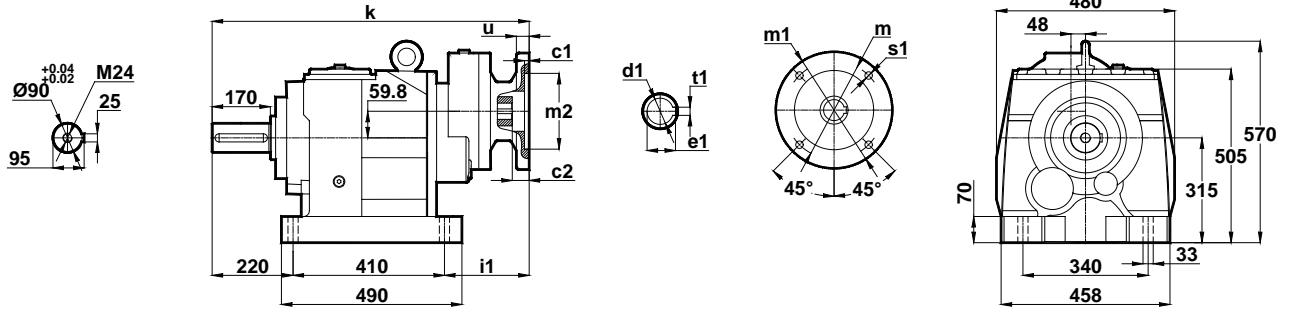

NN774-A..

NN774-B..

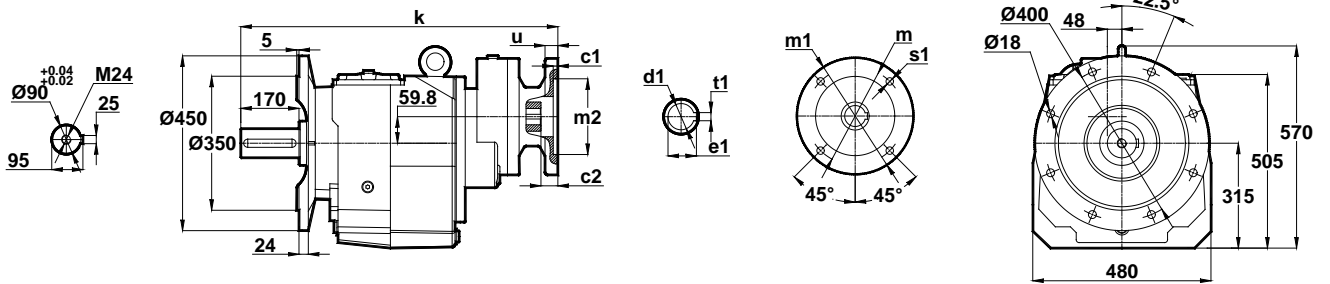

IEC	c1	c2	s1	m	m1	m2	i1	u	k	d1	t1	e1
80/B5	4	5	12	165	200	130	112.5	12	743	19	6	21.8
90/B5	4	5	12	165	200	130	112.5	12	743	24	8	27.3
100/B5	4.5	9	15	215	250	180	131	15	761	28	8	31.3
90/B14	4	5	9	115	140	95	112.5	12	743	24	8	27.3
100/B14	4	9	9	130	160	110	131	15	761	28	8	31.3

Opsiyonel Flanş Ölçüleri / Optional Flange Dimensions / Auswählbare Flanschabmessungen

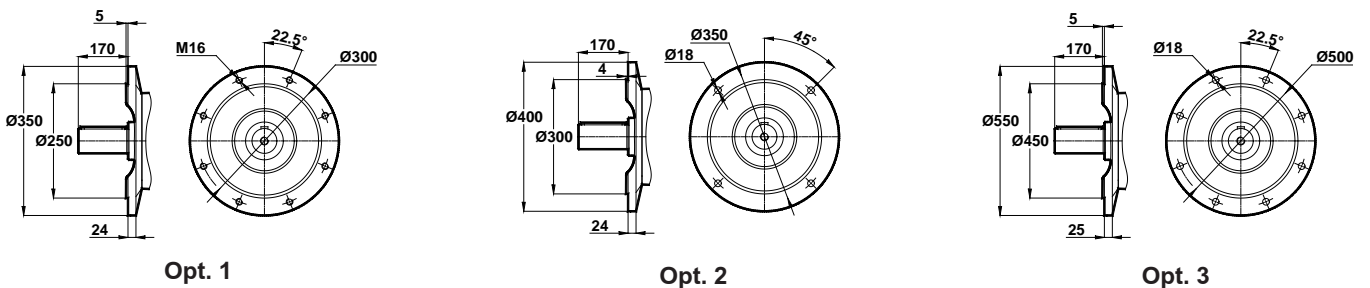

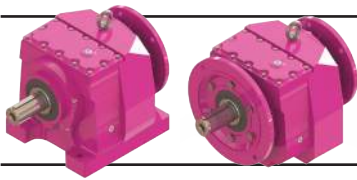

Ölçü Sayfaları

Dimension Pages

Abmessungsseiten



-Mil ucu çektirme deliği DIN 332 sayfa 2 / Tapped center hole to DIN 332, sheet 2 / Zentrierung mit gewinde DIN 332, Blatt 2

MN775-A.. / B.. MN776-A.. / B..

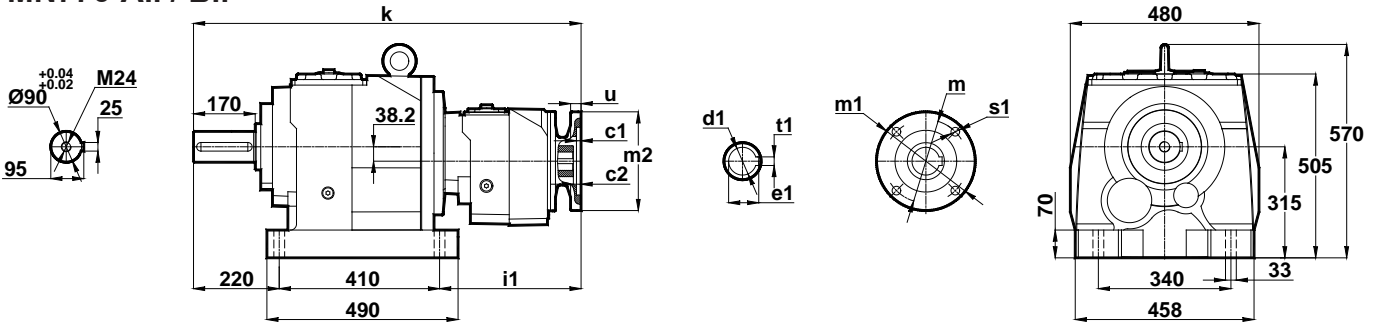

NN775-A.. / B.. NN776-A.. / B..

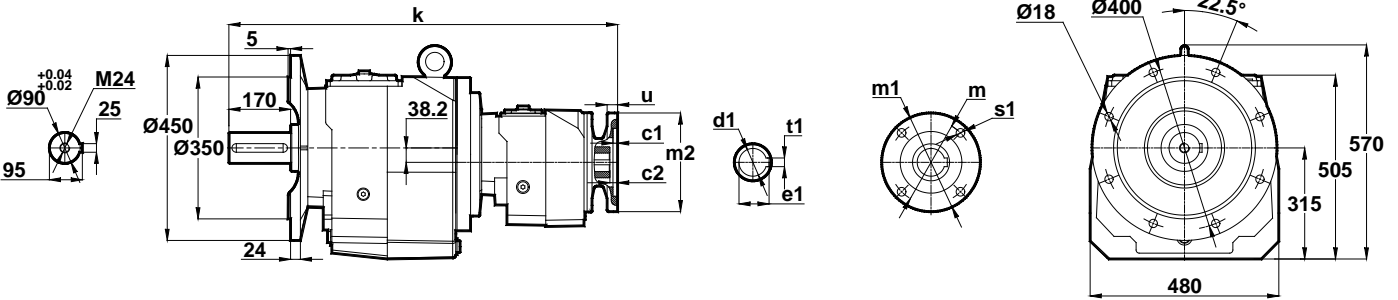

IEC	c1	c2	s1	m	m1	m2	i1	u	k	d1	t1	e1
71/B5	4	9	11	130	160	110	266	12	896	14	5	16.3
80/B5	4	9	12	165	200	130	266	12	869	19	6	21.8
90/B5	4	9	12	165	200	130	266	12	896	24	8	27.3
80/B14	4	9	7	100	120	80	266	12	896	19	6	21.8
90/B14	4	9	9	115	140	95	266	12	896	24	8	26.3

Opsiyonel Flanş Ölçüleri / Optional Flange Dimensions / Auswählbare Flanschabmessungen

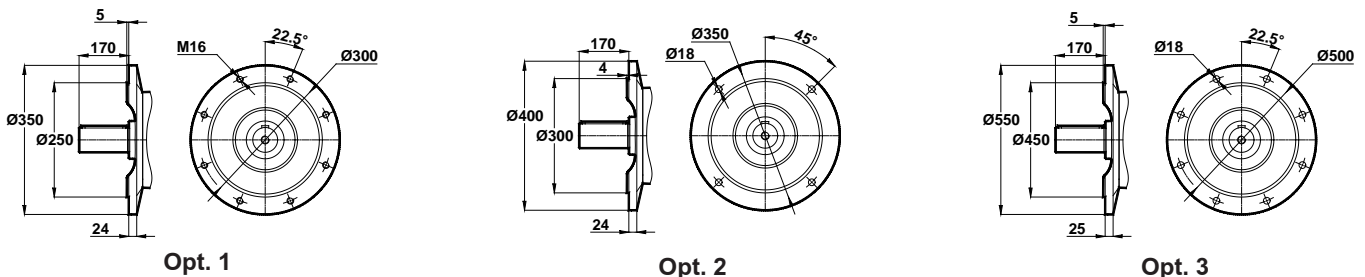

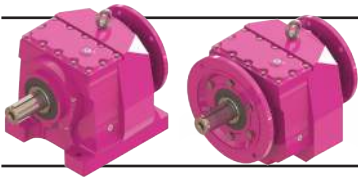

Ölçü Sayfaları Dimension Pages Abmessungsseiten



-Mil ucu çektirme deliği DIN 332 sayfa 2 / Tapped center hole to DIN 332, sheet 2 / Zentrierung mit gewinde DIN 332, Blatt 2

MN872-A.. MN873-A..

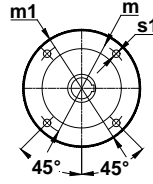
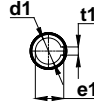
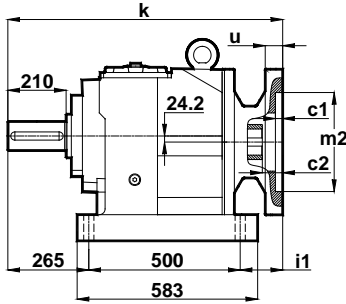
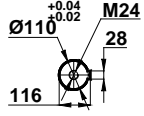

160 - 200 Tip / Type / Typ

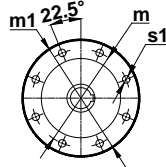
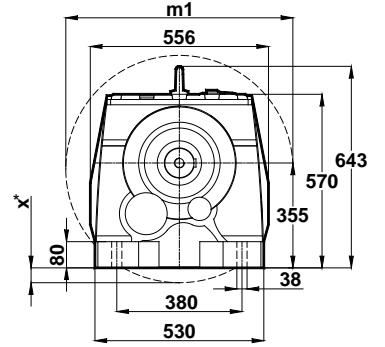

225 - 280 Tip / Type / Typ

NN872-A.. NN873-A..

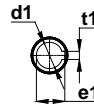
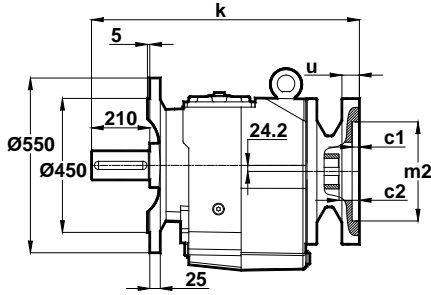
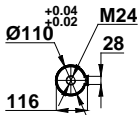

160 - 200 Tip / Type / Typ

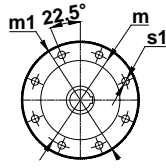
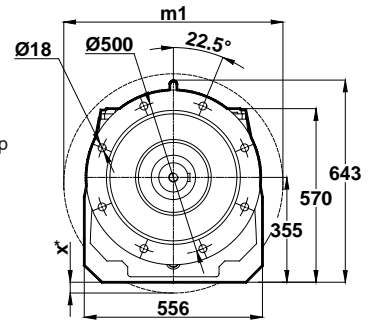

225 - 280 Tip / Type / Typ

IEC	c1	c2	s1	m	m1	m2	i1	u	k	d1	t1	e1	x
160/B5	5.5	10	19	300	350	250	158	20	923	42	12	45.3	-
180/B5	5.5	10	19	300	350	250	158	20	923	48	14	51.8	-
200/B5	5.5	10	19	350	400	300	158	22	923	55	16	59.3	-
225/B5	5.5	10	19	400	450	350	158	24	923	60	18	64.4	-
250/B5	5.5	10	19	500	550	450	158	24	923	65	18	69.4	-
280/B5	5.5	10	19	500	550	450	158	24	923	75	20	79.9	-

Opsiyonel Flanş Ölçüleri / Optional Flange Dimensions / Auswählbare Flanschabmessungen

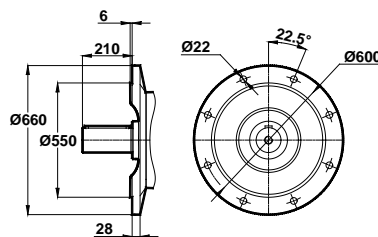

Opt. 1

x: Motor flanşı, ayak bağlantı yüzeyinin altında ise / x: If Motor flange is lower than foot mounting plane / x: Wenn motorflansch ist niedriger den die Anschlußplatte

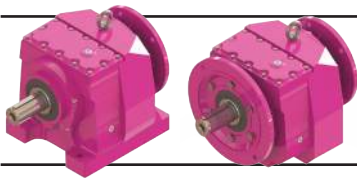

Ölçü Sayfaları

Dimension Pages

Abmessungsseiten



-Mil ucu çekirme deliği DIN 332 sayfa 2 / Tapped center hole to DIN 332, sheet 2 / Zentrierung mit gewinde DIN 332, Blatt 2

MN874-A.. MN874-B..

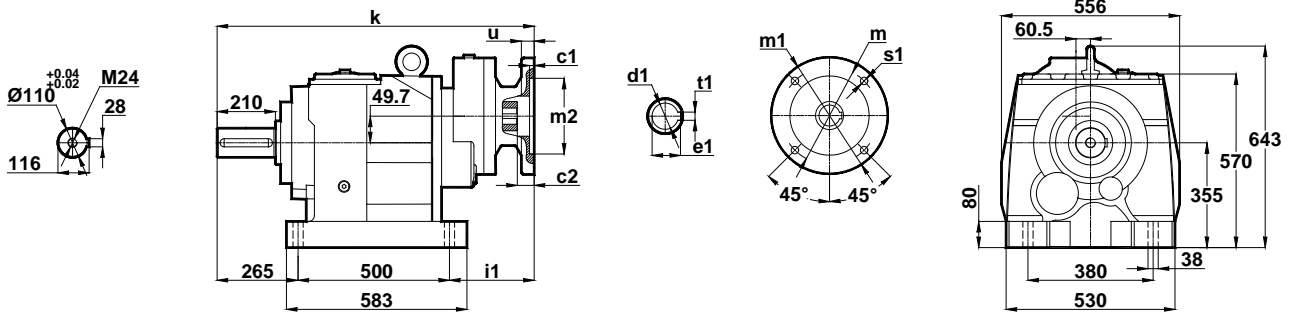

NN874-A.. NN874-B..

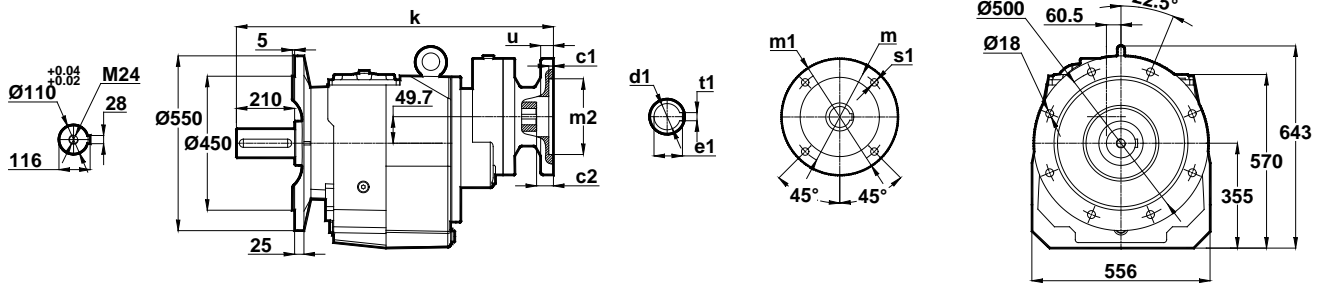

IEC	c1	c2	s1	m	m1	m2	i1	u	k	d1	t1	e1
100/B5	4.5	20	15	215	250	180	130.5	15	896	28	8	31.3
112/B5	4.5	20	15	215	250	180	130.5	15	896	28	8	31.3
132/B5	4.5	9	15	265	300	230	151.5	15	917	38	10	41.3
132/B14	4.5	9	11	165	200	130	151.5	15	917	38	10	41.3

Opsiyonel Flanş Ölçüleri / Optional Flange Dimensions / Auswählbare Flanschabmessungen

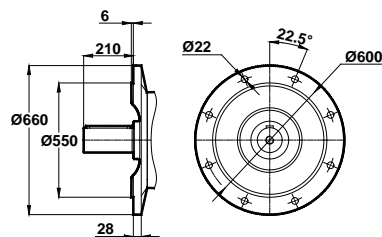

Opt. 1

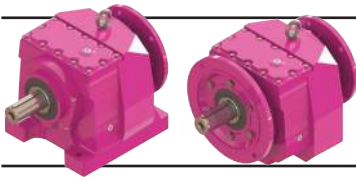

Ölçü Sayfaları

Dimension Pages

Abmessungsseiten



-Mil ucu çektirme deliği DIN 332 sayfa 2 / Tapped center hole to DIN 332, sheet 2 / Zentrierung mit gewinde DIN 332, Blatt 2

MN875-A.. / B..
MN876-A.. / B..

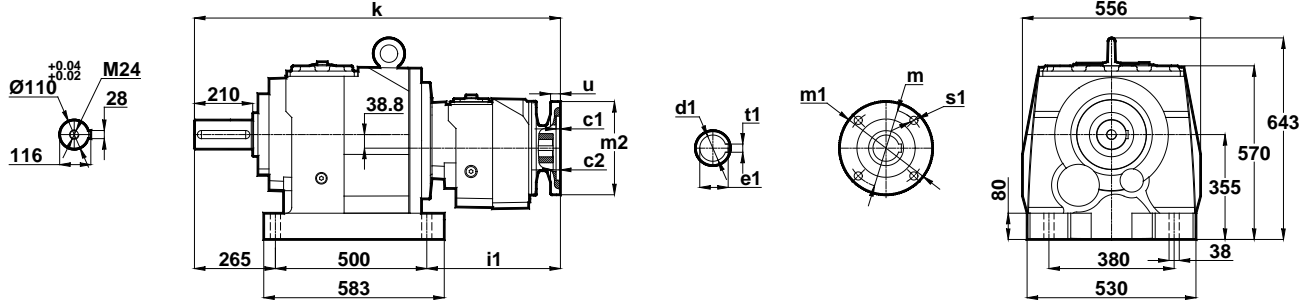

NN875-A.. / B..
NN876-A.. / B..

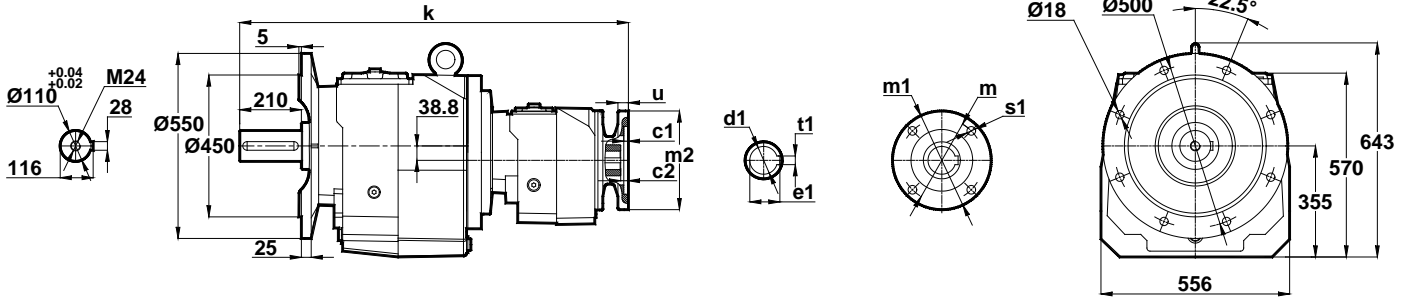

IEC	c1	c2	s1	m	m1	m2	i_1	u	k	d_1	t_1	e_1
71/B5	4	9	11	130	160	110	248	12	1013	14	5	16.3
80/B5	4	9	12	165	200	130	248	12	1013	19	6	21.8
90/B5	4	9	12	165	200	130	248	12	1013	24	8	27.3
100/B5	4.5	9	15	215	250	180	265	15	1030	28	8	31.3
80/B14	4	9	7	100	120	80	248	12	1013	19	8	21.8
90/B14	4	9	9	115	140	95	248	12	1013	24	8	26.3
100/B14	4	9	9	130	160	110	265	15	1030	28	8	31.3

Opsiyonel Flanş Ölçüleri / Optional Flange Dimensions / Auswählbare Flanschabmessungen

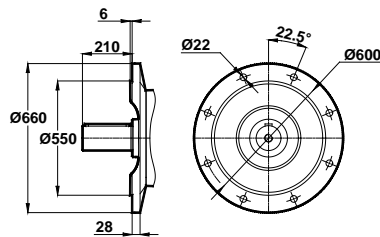

Opt. 1

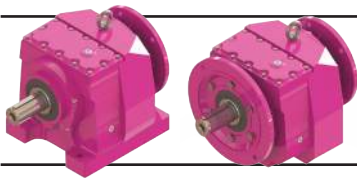

Ölçü Sayfaları

Dimension Pages

Abmessungsseiten



-Mil ucu çektirme deliği DIN 332 sayfa 2 / Tapped center hole to DIN 332, sheet 2 / Zentrierung mit gewinde DIN 332, Blatt 2

MN972-A.. MN973-A..

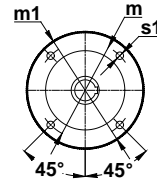
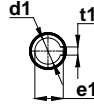
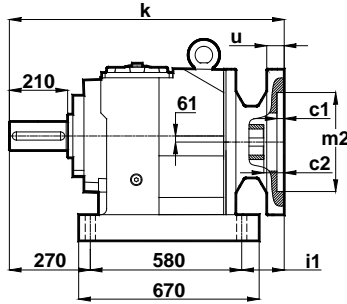
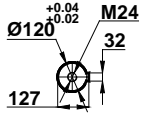

160 - 200 Tip / Type / Typ

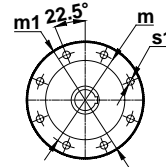
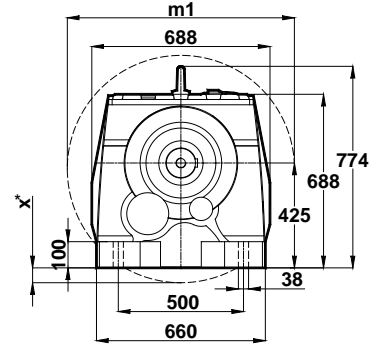

225 - 315 Tip / Type / Typ

NN972-A.. NN973-A..

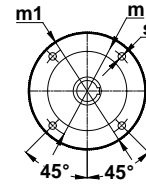
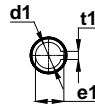
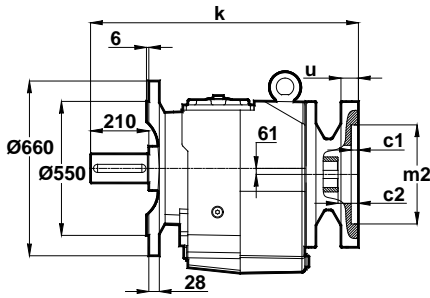
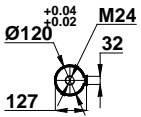

160 - 200 Tip / Type / Typ

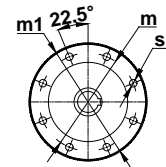
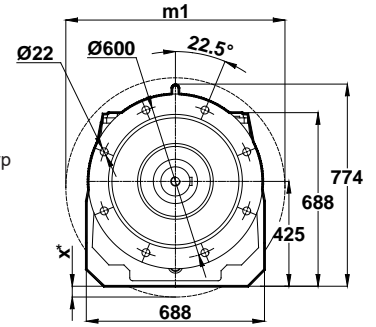

225 - 315 Tip / Type / Typ

IEC	c1	c2	s1	m	m1	m2	i1	u	k	d1	t1	e1	x
160/B5	5.5	10	19	300	350	250	60.5	20	911	42	12	45.3	-
180/B5	5.5	10	19	300	350	250	60.5	20	911	48	14	51.8	-
200/B5	5.5	10	19	350	400	300	84.5	22	935	55	16	59.3	-
225/B5	5.5	10	19	400	450	350	126.5	24	977	60	18	64.4	-
250/B5	5.5	10	19	500	550	450	178.5	24	1029	65	18	69.4	-
280/B5	5.5	10	19	500	550	450	178.5	24	1029	75	20	79.9	-
315/B5	6.5	15	24	660	600	550	228.5	24	1079	85	22	90.4	-

x: Motor flanşı, ayak bağlantı yüzeyinin altında ise / x: If Motor flange is lower then foot mounting plane / x: Wenn motorflansch ist niedriger den die Anschlussplatte

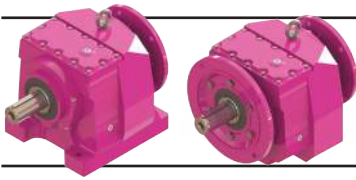

Ölçü Sayfaları

Dimension Pages

Abmessungsseiten



-Mil ucu çektirme deliği DIN 332 sayfa 2 / Tapped center hole to DIN 332, sheet 2 / Zentrierung mit gewinde DIN 332, Blatt 2

MN974-A.. MN974-B..

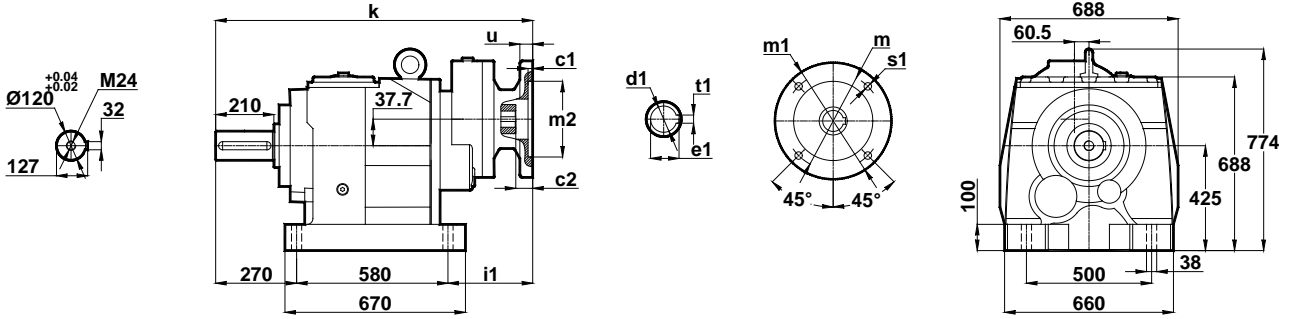

NN974-A.. NN974-B..

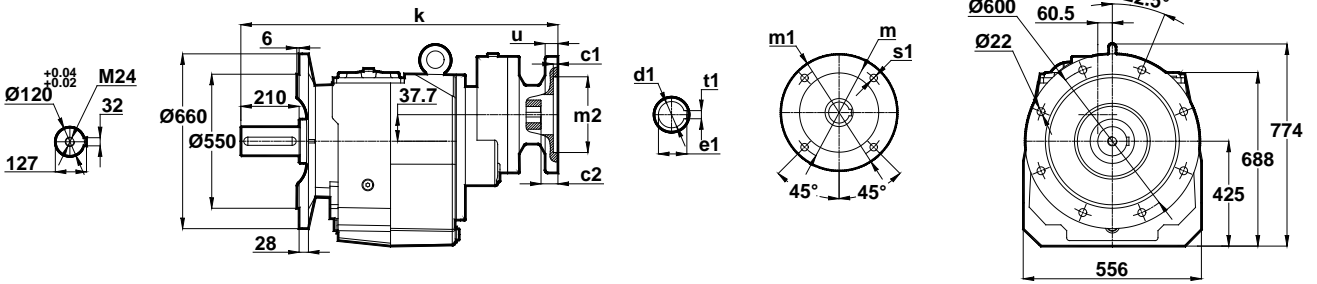

IEC	c1	c2	s1	m	m1	m2	i1	u	k	d1	t1	e1
100/B5	4.5	14.5	15	215	250	180	149	15	1000	28	8	31.3
112/B5	4.5	14.5	15	215	250	180	149	15	1000	28	8	31.3
132/B5	4.5	9	15	265	300	230	164	15	1015	38	10	41.3
132/B14	4.5	9	15	165	200	130	164	15	1015	38	10	41.3

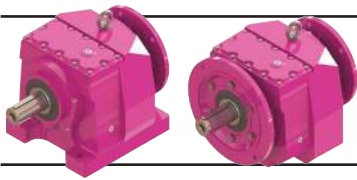

Ölçü Sayfaları

Dimension Pages

Abmessungsseiten



-Mil ucu çekirme deliği DIN 332 sayfa 2 / Tapped center hole to DIN 332, sheet 2 / Zentrierung mit gewinde DIN 332, Blatt 2

MN975-A.. / B.. MN976-A.. / B..

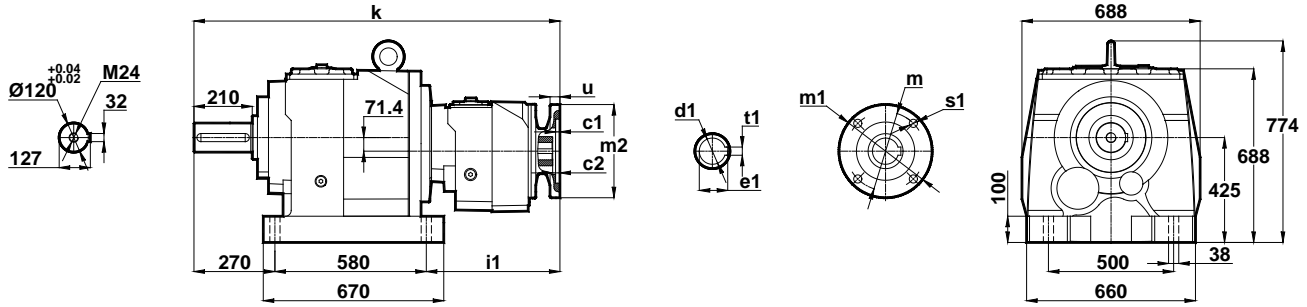

NN975-A.. / B.. NN976-A.. / B..

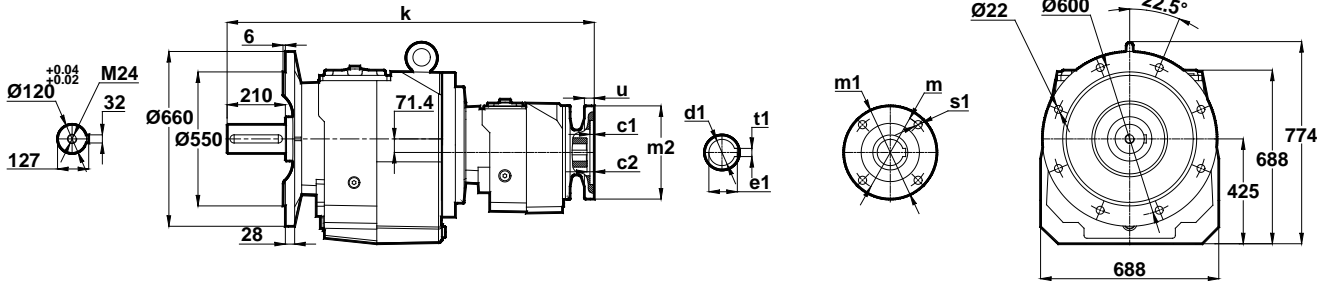

IEC	c1	c2	s1	m	m1	m2	i1	u	k	d1	t1	e1
80/B5	4	5	12	165	200	130	285	12	1136	19	6	12.8
90/B5	4	5	12	165	200	130	285	12	1136	24	8	27.3
100/B5	4.5	9	15	215	250	180	303.5	15	1154	28	8	31.3
112/B5	4.5	9	15	215	250	180	303.5	15	1154	28	8	31.3
132/B5	4.5	6	15	265	300	230	322	15	1173	38	10	41.3
90/B14	4	5	9	115	140	95	285	12	1136	24	8	27.3
100/B14	4	9	9	130	160	110	303.5	15	1154	28	8	31.3
112/B14	4	9	9	130	160	110	303.5	15	1154	28	8	31.3
132/B14	4.4	6	11	165	200	130	322	15	1173	38	10	41.3

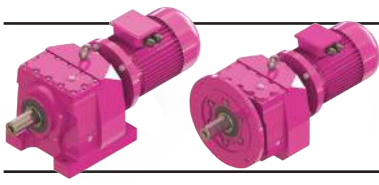

Ölçü Sayfaları Dimension Pages Abmessungsseiten



-Mil ucu çektirme deliği DIN 332 sayfa 2 / Tapped center hole to DIN 332, sheet 2 / Zentrierung mit gewinde DIN 332, Blatt 2

MV002 MV003

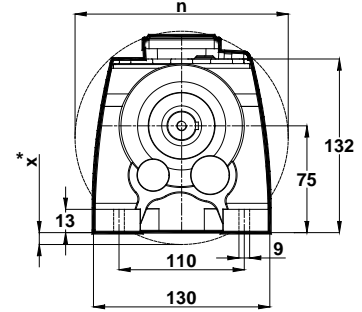
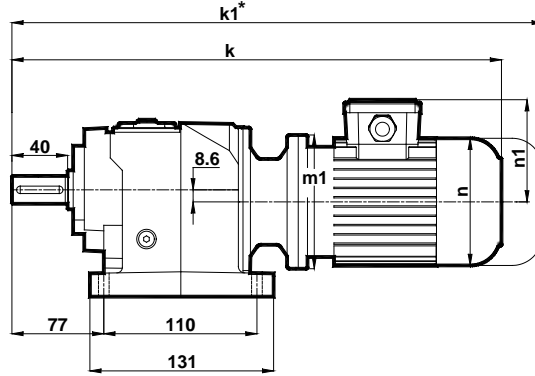
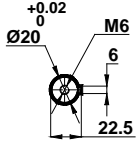

NV002 NV003

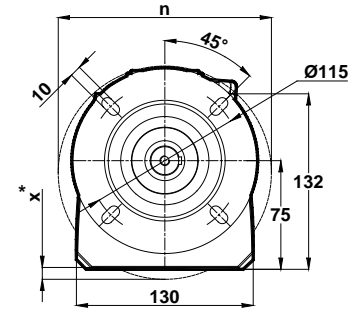
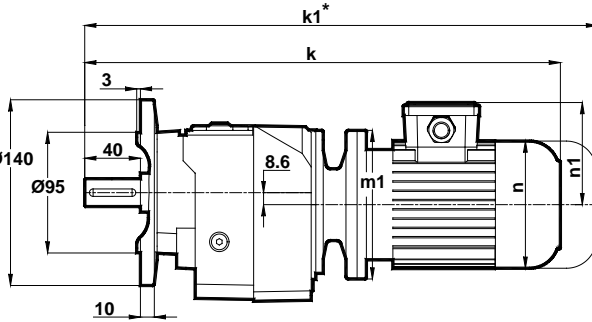
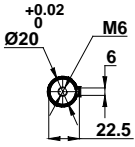

Motor Büyüklüğü / Motor Size / Motorbaugroße					
IEC	63/B5 63/B14	71/B5 71/B14	80/B5 80/B14	90S/B5 90S/B14	90L/B5 90L/B14
k	407	435	470	490	515
k1	460	555	590	615	640
n / n1	121 / 97	138 / 111	156 / 118	176 / 126	176 / 126
m1 (B5)	140	160	200	200	200
m1 (B14)	90	105	120	140	140
x (B5)	4	14	34	34	34

Klemens Kutusu / Terminal Box / Klemmenkasten

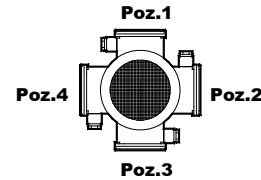

63-71-80-90

Opsiyonel Flanş Ölçüleri / Optional Flange Dimensions / Auswählbare Flanschabmessungen

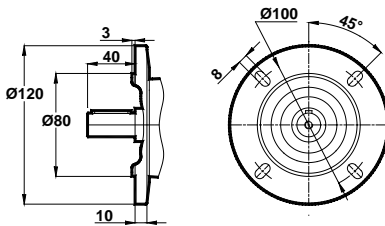

Opt. 1

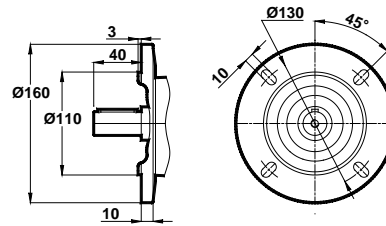

Opt. 2

* " k1 " Ölçüsü frenli redüktörlere aittir. 63, 71 tip elektrik motorlu redüktörler soğutmasız, diğerleri soğutmalıdır.

Dimension " k1 " is for motors with brake. Gearboxes with 63 and 71 type electrical motors are not fan cooled, other types are fan cooled.

Maße " k1 " ist für Bremsenmotoren. Getrieben mit 63 und 71 typ Motoren sind ohne Kühlung, andere Typen sind mit Ventilator gekühlt.

x: Motor, ayak bağlantı yüzeyinin altında ise / x: If Motor is lower then foot mounting plane / x: Wenn motor ist niedriger den die Anschlußplatte

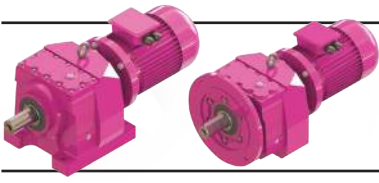

Ölçü Sayfaları Dimension Pages Abmessungsseiten



-Mil ucu çektirme deliği DIN 332 sayfa 2 / Tapped center hole to DIN 332, sheet 2 / Zentrierung mit gewinde DIN 332, Blatt 2

MV102 MV103

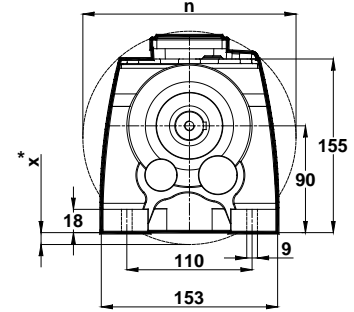
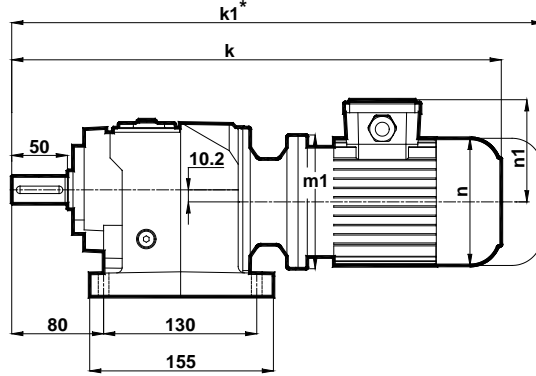
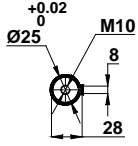

NV102 NV103

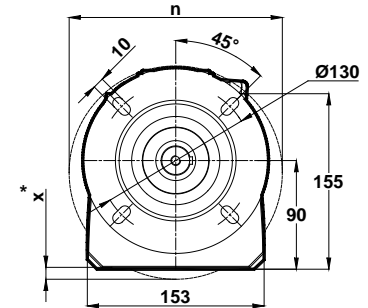
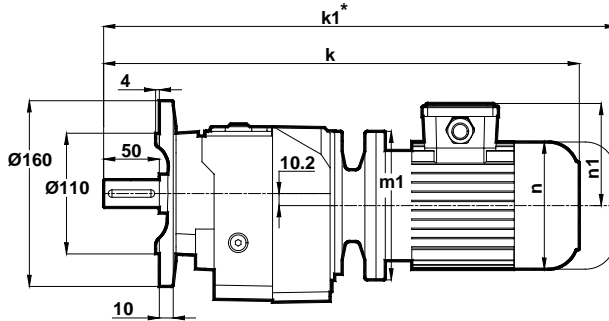
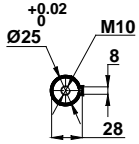

Motor Büyüklüğü / Motor Size / Motorbaugroße					
IEC	63/B5 63/B14	71/B5 71/B14	80/B5 80/B14	90S/B5 90S/B14	90L/B5 90L/B14
k	433	459	494	514	539
k1	486	579	614	639	664
n / n1	121 / 97	138 / 111	156 / 118	176 / 126	176 / 126
m1 (B5)	140	160	200	200	200
m1 (B14)	90	105	120	140	140
x (B5)	-	1	21	21	21

Klemens Kutusu / Terminal Box / Klemmenkasten

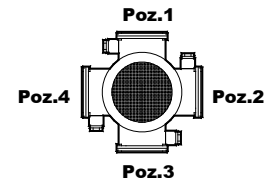

63-71-80-90

Opsiyonel Flanş Ölçüleri / Optional Flange Dimensions / Auswählbare Flanschabmessungen

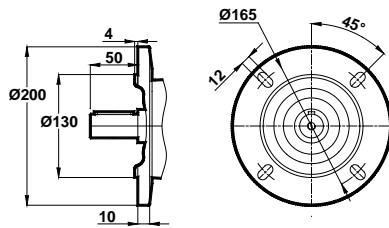

Opt. 1

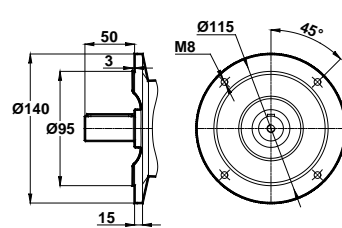

Opt. 2

* "k1" Ölçüsü frenli redüktörlere aittir. 63, 71 tip elektrik motorlu redüktörler soğutmasız, diğerleri soğutmalıdır.

Dimension "k1" is for motors with brake. Gearboxes with 63 and 71 type electrical motors are not fan cooled, other types are fan cooled.

Maße "k1" ist für Bremsenmotoren. Getrieben mit 63 und 71 typ Motoren sind ohne Kühlung, andere Typen sind mit Ventilator gekühlt.

x: Motor Ayak bağlantı yüzeyinin altında ise / x: If Motor is lower than foot mounting plane / x: Wenn motor ist niedriger den die Anschlußplatte

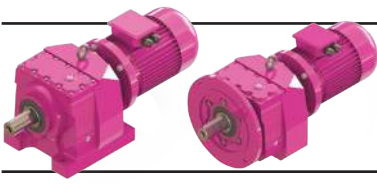

Ölçü Sayfaları Dimension Pages Abmessungenseiten



-Mil ucu çektirme deliği DIN 332 sayfa 2 / Tapped center hole to DIN 332, sheet 2 / Zentrierung mit gewinde DIN 332, Blatt 2

MV172 MV173

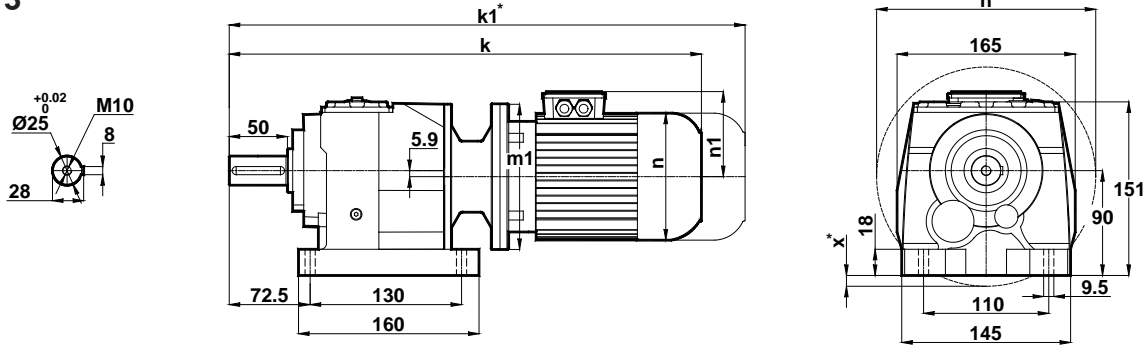

NV172 NV173

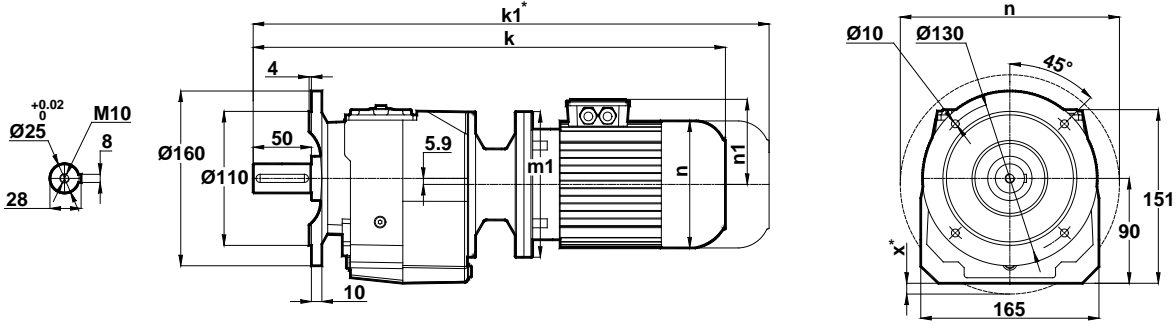

Motor Büyüklüğü / Motor Size / Motorbaugroße							
IEC	63/B5	71/B5 71/B14	80/B5 80/B14	90S/B5 90S/B14	90L/B5 90L/B14	100L/B5 100L/B14	112M/B5 112M/B14
k	434	462	497	517	542	585	605
k1	487	582	617	642	667	720	740
n / n1	121 / 97	138 / 111	156 / 118	176 / 126	176 / 126	194 / 135	218 / 146
m1 (B5)	140	160	200	200	200	250	250
m1 (B14)	-	105	120	140	140	160	160
x (B5)	-	-	16	16	16	41	41

Klemens Kutusu / Terminal Box / Klemmenkasten

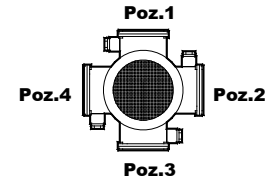

63-71-80-90-100-112

Opsiyonel Flanş Ölçüleri / Optional Flange Dimensions / Auswählbare Flanschabmessungen

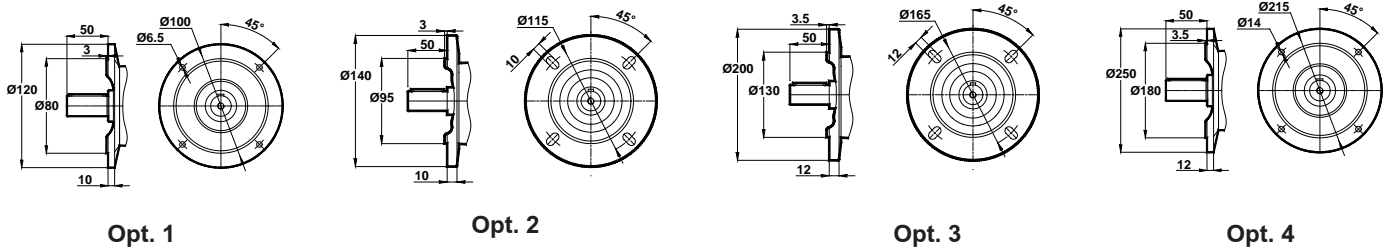

* "k1" Ölçüsü frenli redüktörlere aittir. 63, 71 tip elektrik motorlu redüktörler soğutmasız, diğerleri soğutmalıdır.
Dimension "k1" is for motors with brake. Gearboxes with 63 and 71 type electrical motors are not fan cooled, other types are fan cooled.
Maße "k1" ist für Bremsenmotoren. Getrieben mit 63 und 71 typ Motoren sind ohne Kühlung, andere Typen sind mit Ventilator gekühlt.
x: Motor, ayak bağlantı yüzeyinin altında ise / x: If Motor is lower than foot mounting plane / x: Wenn motor ist niedriger den die Anschlußplatte

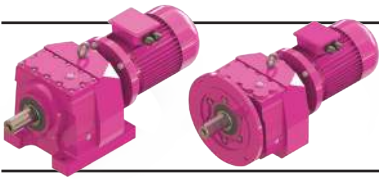

Ölçü Sayfaları Dimension Pages Abmessungsseiten



-Mil ucu çektirme deliği DIN 332 sayfa 2 / Tapped center hole to DIN 332, sheet 2 / Zentrierung mit gewinde DIN 332, Blatt 2

MV202 MV203

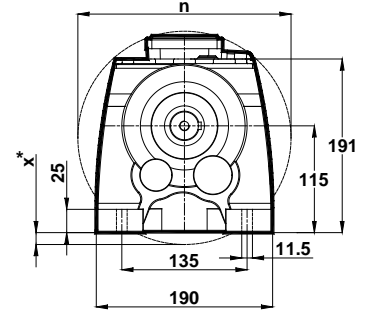
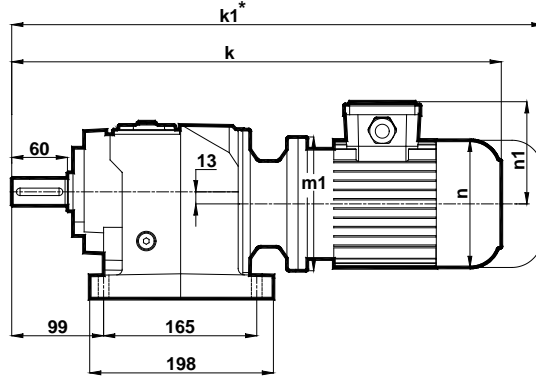
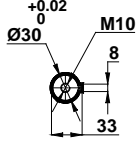

NV202 NV203

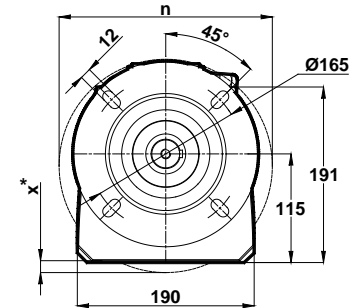
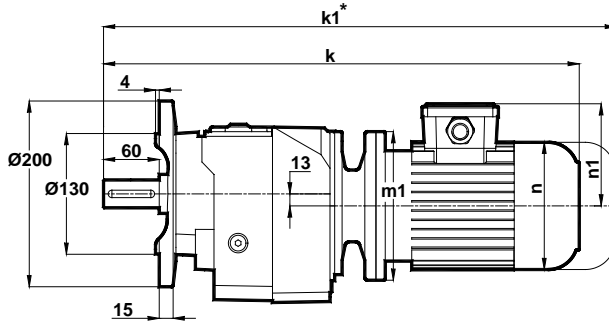
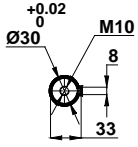

Motor Büyüklüğü / Motor Size / Motorbaugroße							
IEC	63/B5	71/B5 71/B14	80/B5 80/B14	90S/B5 90S/B14	90L/B5 90L/B14	100L/B5 100L/B14	112M/B5 112M/B14
k	516	513	562	582	607	632	652
k1	569	633	682	707	732	767	787
n / n1	121 / 97	138 / 111	156 / 118	176 / 126	176 / 126	194 / 135	218 / 146
m1 (B5)	140	160	200	200	200	250	250
m1 (B14)	-	105	120	140	140	160	160
x (B5)	-	-	-	-	-	23	23

Klemens Kutusu / Terminal Box / Klemmenkasten

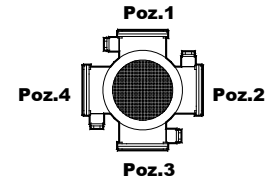

63-71-80-90-100-112

Opsiyonel Flanş Ölçüleri / Optional Flange Dimensions / Auswählbare Flanschabmessungen

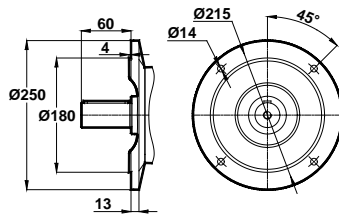

Opt. 1

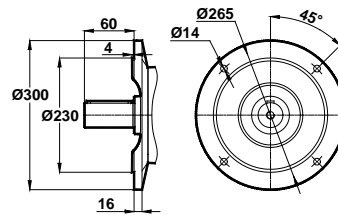

Opt. 2

* "k1" Ölçüsü frenli redüktörlere aittir. 63, 71 tip elektrik motorlu redüktörler soğutmasız, diğerleri soğutmalıdır.

Dimension "k1" is for motors with brake. Gearboxes with 63 and 71 type electrical motors are not fan cooled, other types are fan cooled.

Maße "k1" ist für Bremsenmotoren. Getrieben mit 63 und 71 typ Motoren sind ohne Kühlung, andere Typen sind mit Ventilator gekühlt.

x: Motor Ayak bağlantı yüzeyinin altında ise / x: If Motor is lower than foot mounting plane / x: Wenn motor ist niedriger den die Anschlußplatte

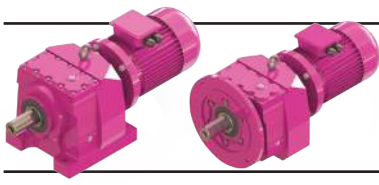

Ölçü Sayfaları Dimension Pages Abmessungsseiten



-Mil ucu çektirme deliği DIN 332 sayfa 2 / Tapped center hole to DIN 332, sheet 2 / Zentrierung mit gewinde DIN 332, Blatt 2

MV272 MV273

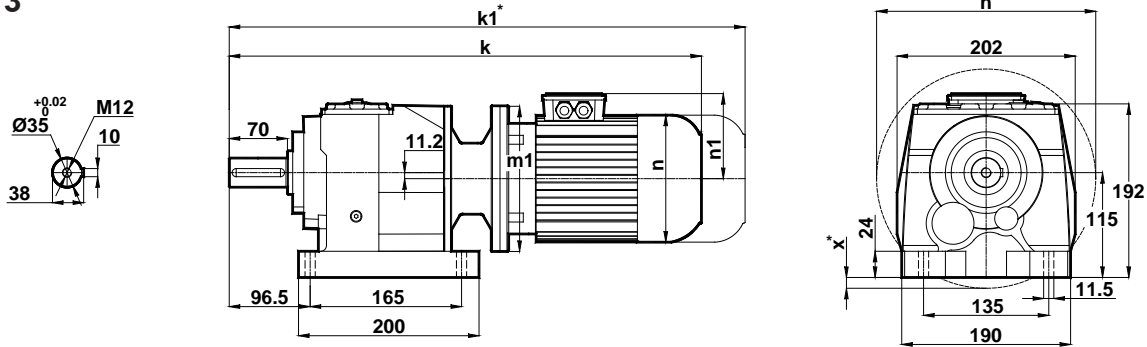

NV272 NV273

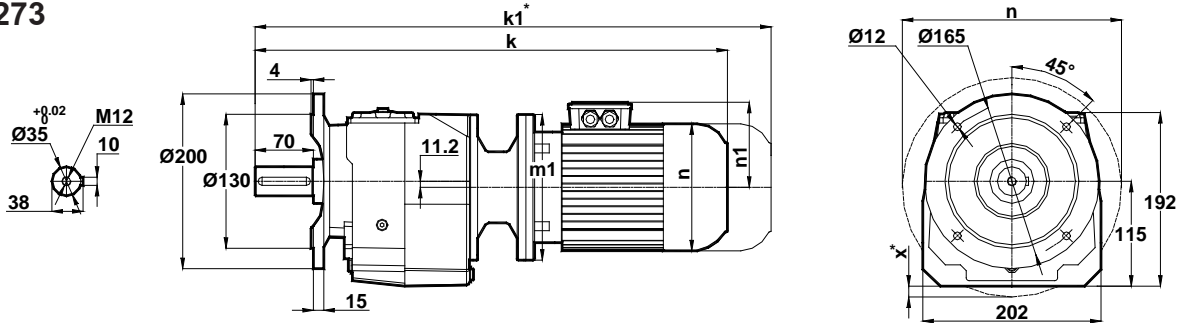

Motor Büyüklüğü / Motor Size / Motorbaugröße							
IEC	63/B5	71/B5 71/B14	80/B5 80/B14	90S/B5 90S/B14	90L/B5 90L/B14	100L/B5 100L/B14	112M/B5 112M/B14
k	517	514	563	583	608	633	653
k1	570	634	683	708	733	768	788
n / n1	121 / 97	138 / 111	156 / 118	176 / 126	176 / 126	194 / 135	218 / 146
m1 (B5)	140	160	200	200	200	250	250
m1 (B14)	-	105	120	140	140	160	160
x (B5)	-	-	-	-	-	22	22

Klemens Kutusu / Terminal Box / Klemmenkasten

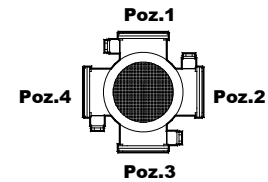

63-71-80-90-100-112

Opsiyonel Flanş Ölçüleri / Optional Flange Dimensions / Auswählbare Flanschabmessungen

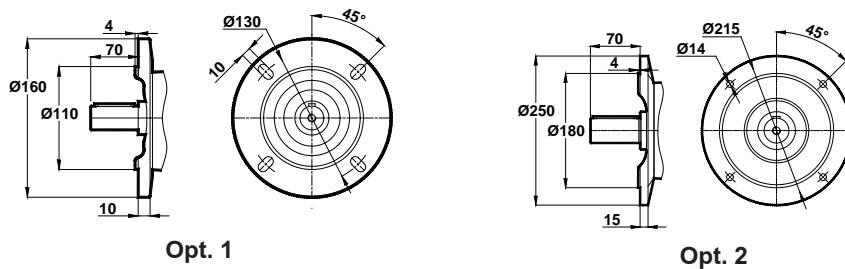

* " k1 " Ölçüsü frenli redüktörlere aittir. 63, 71 tip elektrik motorlu redüktörler soğutmasız, diğerleri soğutmalıdır.
Dimension " k1 " is for motors with brake. Gearboxes with 63 and 71 type electrical motors are not fan cooled, other types are fan cooled.
Maße " k1 " ist für Bremsenmotoren. Getrieben mit 63 und 71 typ Motoren sind ohne Kühlung, andere Typen sind mit Ventilator gekühlt.
x: Motor, ayak bağlantı yüzeyinin altında ise / x: If Motor is lower then foot mounting plane / x: Wenn motor ist niedriger den die Anschlußplatte

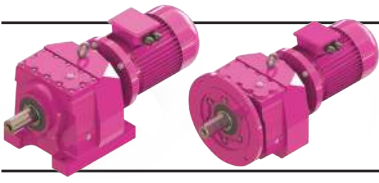

Ölçü Sayfaları Dimension Pages Abmessungsseiten



-Mil ucu çektirme deliği DIN 332 sayfa 2 / Tapped center hole to DIN 332, sheet 2 / Zentrierung mit gewinde DIN 332, Blatt 2

MV275 MV276

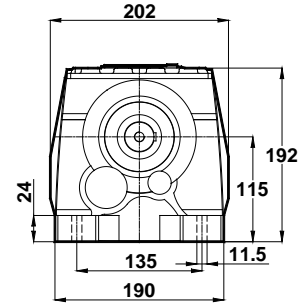
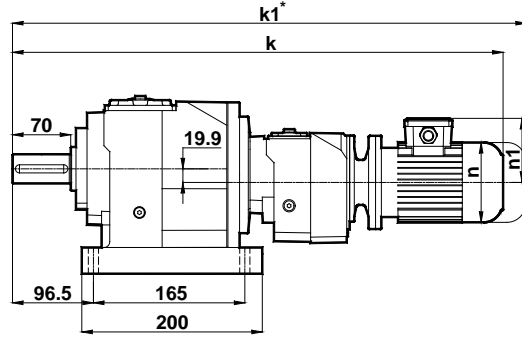
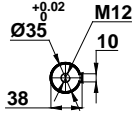

NV275 NV276

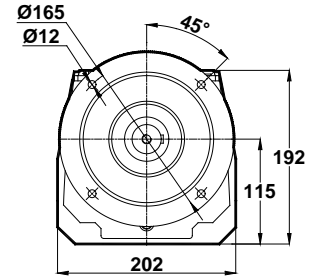
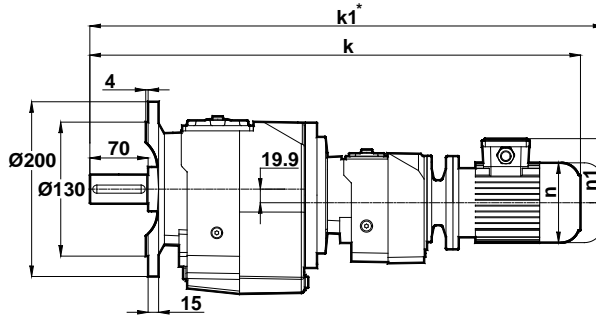
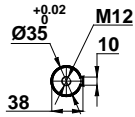

Motor Büyüklüğü / Motor Size / Motorbaugroße		
IEC	63/B5 63/B14	71/B5 71/B14
k	632	660
k1	685	780
n / n1	121 / 97	138 / 111
m1 (B5)	140	160
m1 (B14)	90	105

Klemens Kutusu / Terminal Box / Klemmenkasten

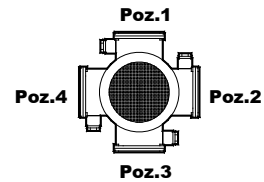

63-71

Opsiyonel Flanş Ölçüleri / Optional Flange Dimensions / Auswählbare Flanschabmessungen

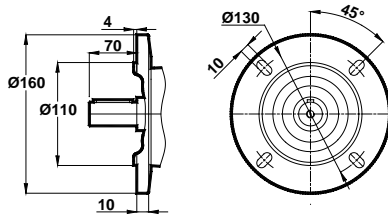

Opt. 1

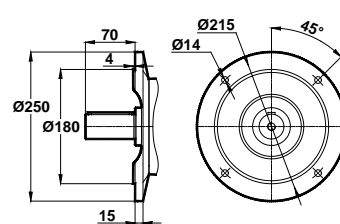

Opt. 2

* " k1 " Ölçüsü frenli redüktörlere aittir. 63, 71 tip elektrik motorlu redüktörler soğutmasız, diğerleri soğutmalıdır.

Dimension " k1 " is for motors with brake. Gearboxes with 63 and 71 type electrical motors are not fan cooled, other types are fan cooled.
Maße " k1 " ist für Bremsenmotoren. Getrieben mit 63 und 71 typ Motoren sind ohne Kühlung, andere Typen zind mit Ventilator gekühlt.

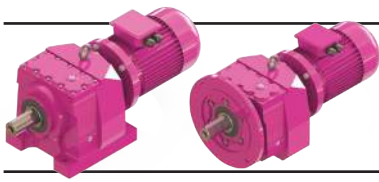

Ölçü Sayfaları Dimension Pages Abmessungsseiten



-Mil ucu çektirme deliği DIN 332 sayfa 2 / Tapped center hole to DIN 332, sheet 2 / Zentrierung mit gewinde DIN 332, Blatt 2

MV282 MV283

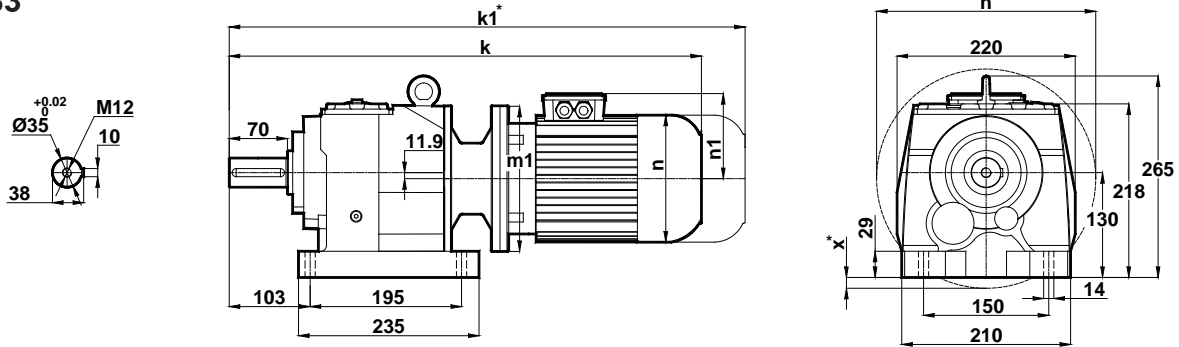

NV282 NV283

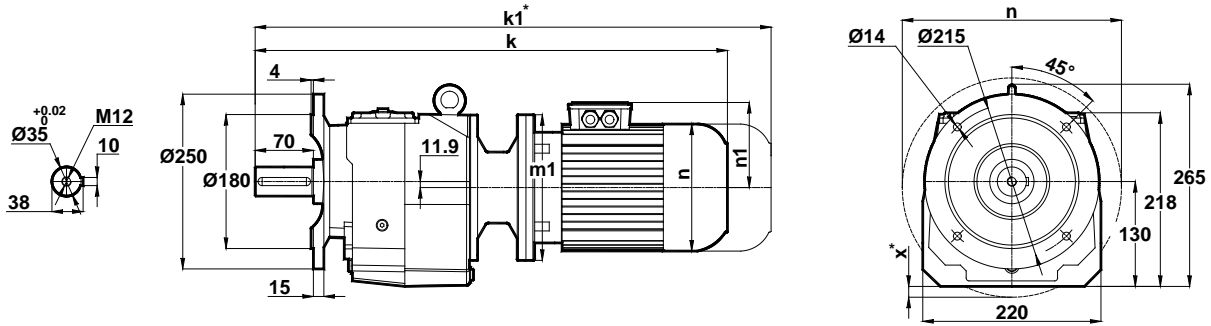

Motor Büyüklüğü / Motor Size / Motorbaugroße								
IEC	71/B5	80/B5 80/B14	90S/B5 90S/B14	90L/B5 90L/B14	100L/B5 100L/B14	112M/B5 112M/B14	132S/B5 132S/B14	132M/B5 132M/B14
k	562	582	602	627	666	686	760	798
k1	682	702	727	752	801	821	905	943
n / n1	138 / 111	156 / 118	176 / 126	176 / 126	194 / 135	218 / 146	257 / 168	257 / 168
m1 (B5)	160	200	200	200	250	250	300	300
m1 (B14)	-	120	140	140	160	160	200	200
x (B5)	-	-	-	-	7	7	32	32

Klemens Kutusu / Terminal Box / Klemmenkasten

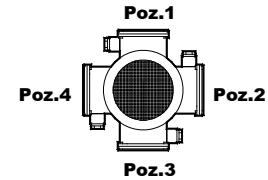

71-80-90-100-112-132

Opsiyonel Flanş Ölçüleri / Optional Flange Dimensions / Auswählbare Flanschabmessungen

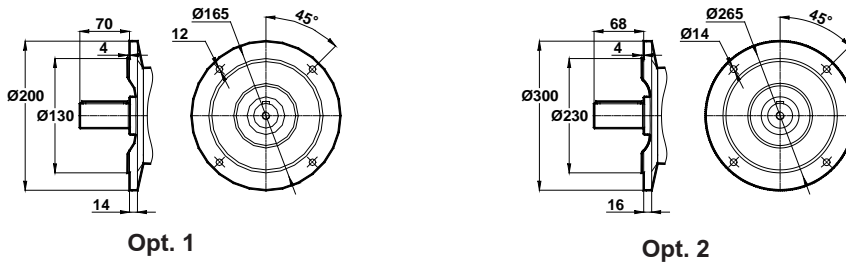

* " k1 " Ölçüsü frenli redüktörlere aittir. 63, 71 tip elektrik motorlu redüktörler soğutmasız, diğerleri soğutmalıdır.
Dimension " k1 " is for motors with brake. Gearboxes with 63 and 71 type electrical motors are not fan cooled, other types are fan cooled.
Maße " k1 " ist für Bremsenmotoren. Getrieben mit 63 und 71 typ Motoren sind ohne Kühlung, andere Typen sind mit Ventilator gekühlt.
x: Motor, ayak bağlantı yüzeyinin altında ise / x: If Motor is lower then foot mounting plane / x: Wenn motor ist niedriger den die Anschlußplatte

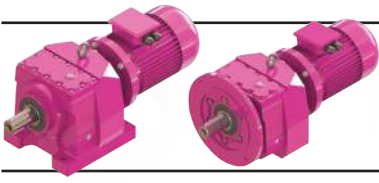

Ölçü Sayfaları

Dimension Pages

Abmessungsseiten



-Mil ucu çektirme deliği DIN 332 sayfa 2 / Tapped center hole to DIN 332, sheet 2 / Zentrierung mit gewinde DIN 332, Blatt 2

MV284

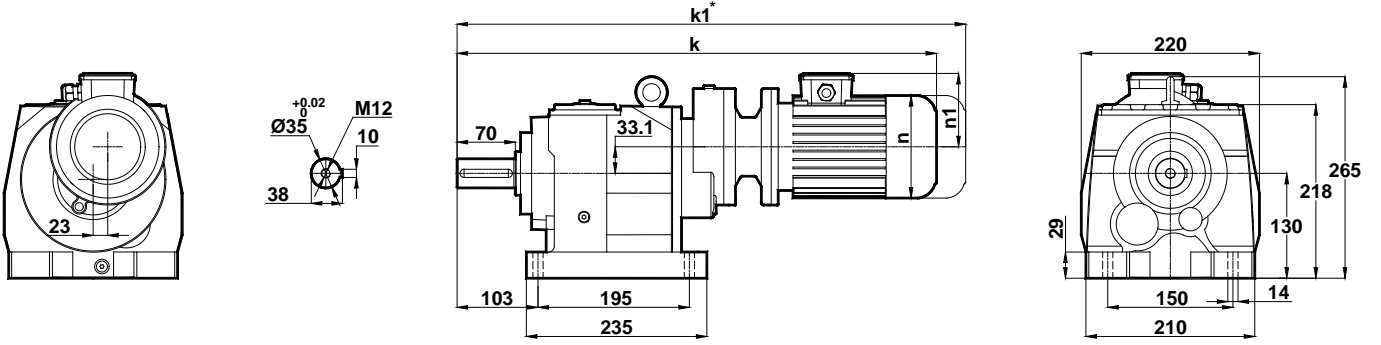

NV284

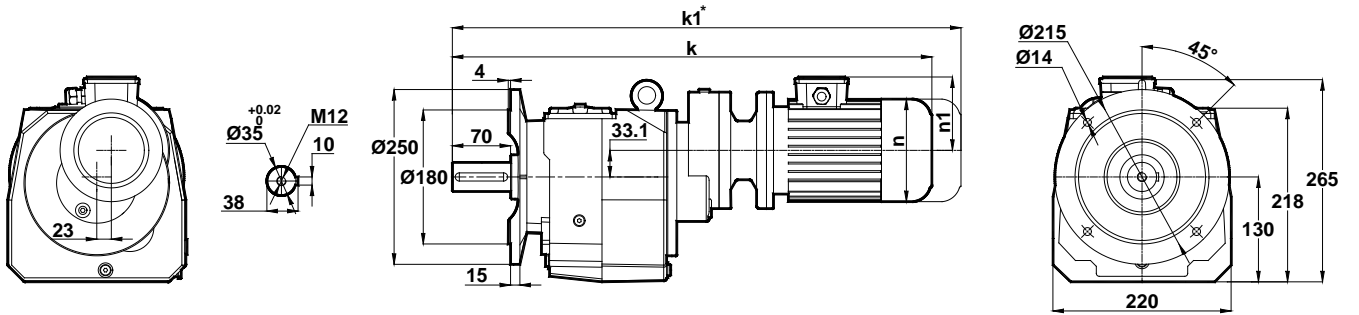

Motor Büyüklüğü / Motor Size / Motorbaugröße		
IEC	63/B5	71/B5 71/B14
k	613	610
k1	666	730
n / n1	121 / 97	138 / 111
m1 (B5)	140	160
m1 (B14)	-	105

Klemens Kutusu / Terminal Box / Klemmenkasten

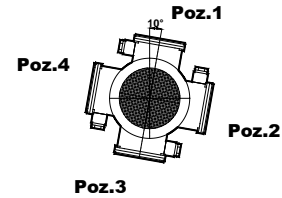

63-71

Opsiyonel Flanş Ölçüleri / Optional Flange Dimensions / Auswählbare Flanschabmessungen

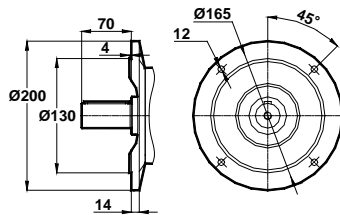

Opt. 1

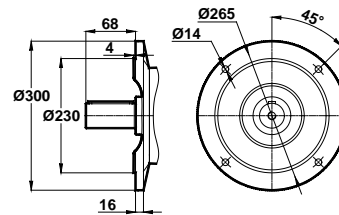

Opt. 2

* "k1" Ölçüsü frenli redüktörlere aittir. 63, 71 tip elektrik motorlu redüktörler soğutmasız, diğerleri soğutmalıdır.

Dimension "k1" is for motors with brake. Gearboxes with 63 and 71 type electrical motors are not fan cooled, other types are fan cooled.

Maße "k1" ist für Bremsenmotoren. Getrieben mit 63 und 71 typ Motoren sind ohne Kühlung, andere Typen sind mit Ventilator gekühlt.

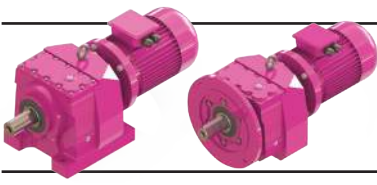

Ölçü Sayfaları Dimension Pages Abmessungsseiten



-Mil ucu çektirme deliği DIN 332 sayfa 2 / Tapped center hole to DIN 332, sheet 2 / Zentrierung mit gewinde DIN 332, Blatt 2

MV285 MV286

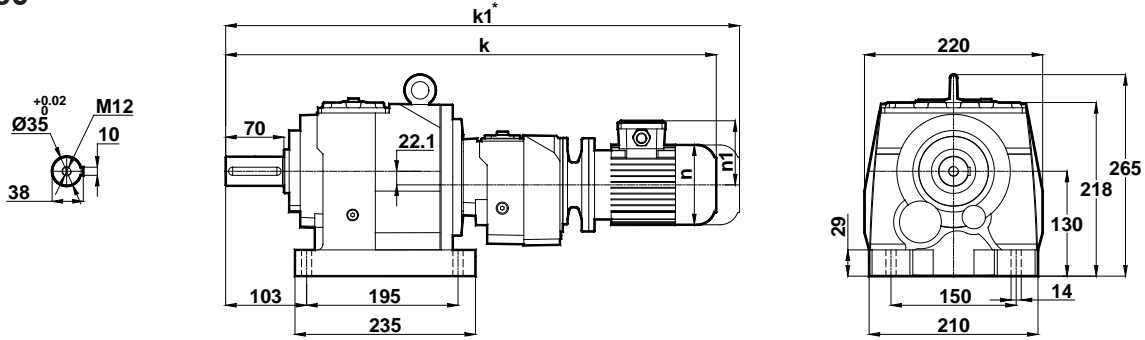

NV285 NV286

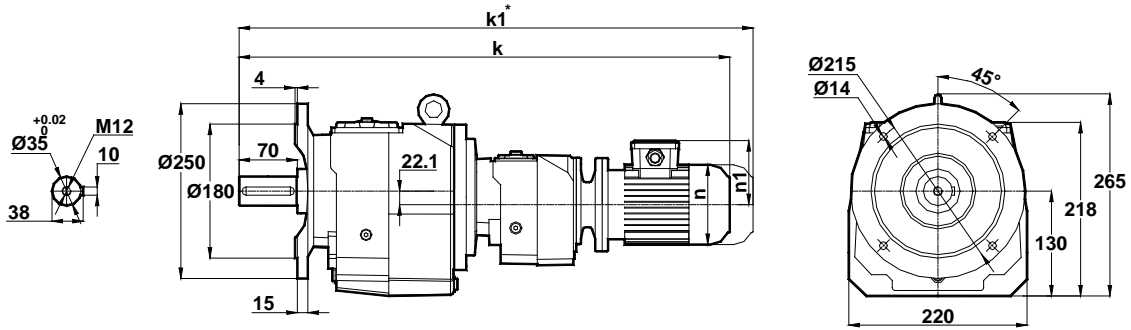

Motor Büyüklüğü / Motor Size / Motorbaugröße	
IEC	63/B5 63/B14
k	679
k1	732
n / n1	121 / 97
m1 (B5)	140
m1 (B14)	90

Klemens Kutusu / Terminal Box / Klemmenkasten

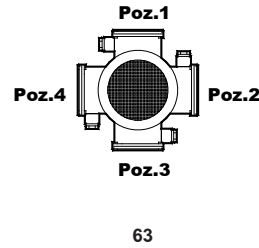

Opsiyonel Flanş Ölçüleri / Optional Flange Dimensions / Auswählbare Flanschabmessungen

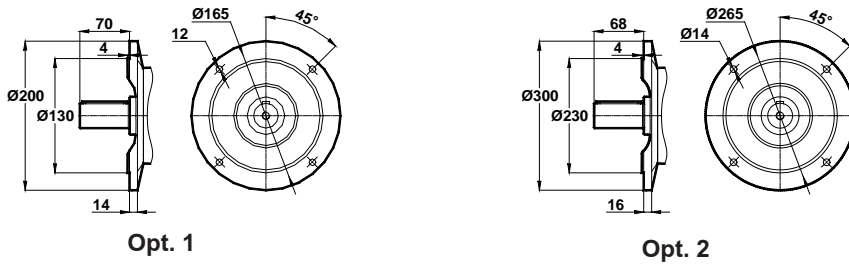

* " k1 " Ölçüsü frenli redüktörlere aittir. 63, 71 tip elektrik motorlu redüktörler soğutmasız, diğerleri soğutmalıdır.
Dimension " k1 " is for motors with brake. Gearboxes with 63 and 71 type electrical motors are not fan cooled, other types are fan cooled.
Maße " k1 " ist für Bremsenmotoren. Getrieben mit 63 und 71 typ Motoren sind ohne Kühlung, andere Typen zind mit Ventilator gekühlt.

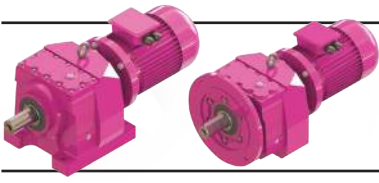

Ölçü Sayfaları Dimension Pages Abmessungsseiten



-Mil ucu çektirme deliği DIN 332 sayfa 2 / Tapped center hole to DIN 332, sheet 2 / Zentrierung mit gewinde DIN 332, Blatt 2

MV372 MV373

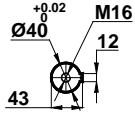
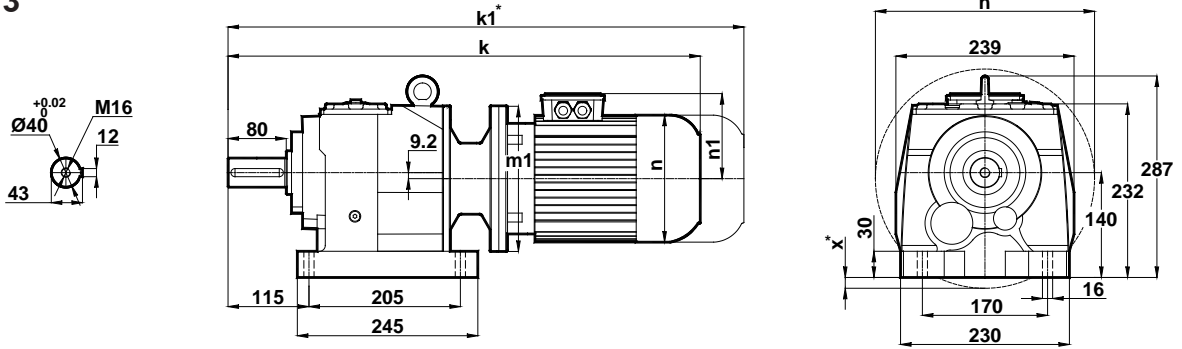

NV372 NV373

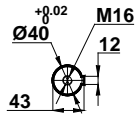
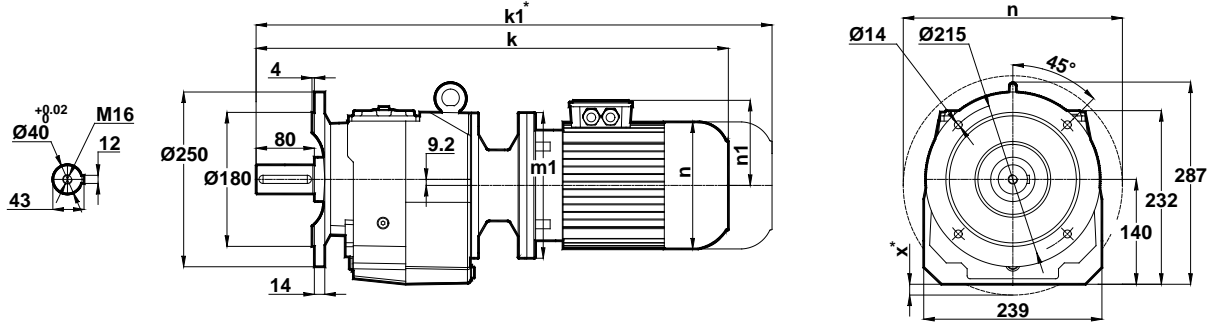

Motor Büyüklüğü / Motor Size / Motorbaugroße								
IEC	71/B5	80/B5 80/B14	90S/B5 90S/B14	90L/B5 90L/B14	100L/B5 100L/B14	112M/B5 112M/B14	132S/B5 132S/B14	132M/B5 132M/B14
k	583	603	623	648	697	717	781	819
k1	703	723	748	773	832	852	926	964
n / n1	138 / 111	156 / 118	176 / 126	176 / 126	194 / 135	218 / 146	257 / 168	257 / 168
m1 (B5)	160	200	200	200	250	250	300	300
m1 (B14)	-	120	140	140	160	160	200	200
x (B5)	-	-	-	-	-	-	20	20

Klemens Kutusu / Terminal Box / Klemmenkasten

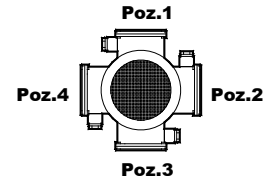

71-80-90-100-112-132

Opsiyonel Flanş Ölçüleri / Optional Flange Dimensions / Auswählbare Flanschabmessungen

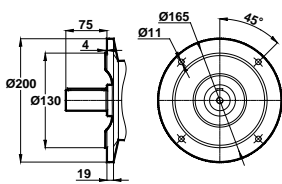

Opt. 1

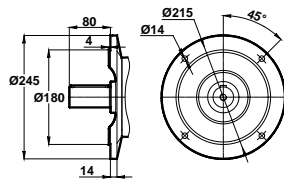

Opt. 2

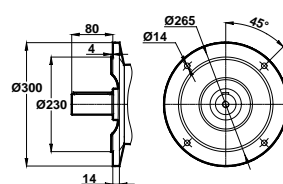

Opt. 3

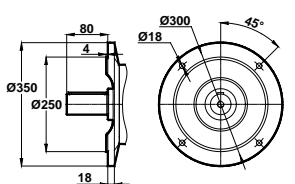

Opt. 4

* "k1" Ölçüsü frenli redüktörlere aittir. 63, 71 tip elektrik motorlu redüktörler soğutmasız, diğerleri soğutmalıdır.

Dimension "k1" is for motors with brake. Gearboxes with 63 and 71 type electrical motors are not fan cooled, other types are fan cooled.

Maße "k1" ist für Bremsenmotoren. Getrieben mit 63 und 71 typ Motoren sind ohne Kühlung, andere Typen sind mit Ventilator gekühlt.

x: Motor Ayak bağlantı yüzeyinin altında ise / x: If Motor is lower than foot mounting plane / x: Wenn motor ist niedriger den die Anschlußplatte

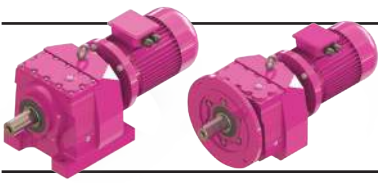

Ölçü Sayfaları Dimension Pages Abmessungsseiten



-Mil ucu çekirme deliği DIN 332 sayfa 2 / Tapped center hole to DIN 332, sheet 2 / Zentrierung mit gewinde DIN 332, Blatt 2

MV374

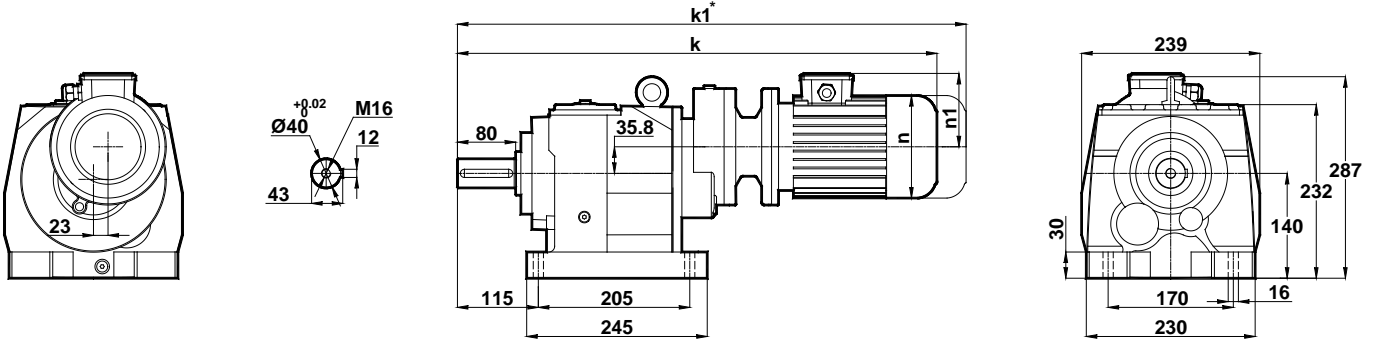

NV374

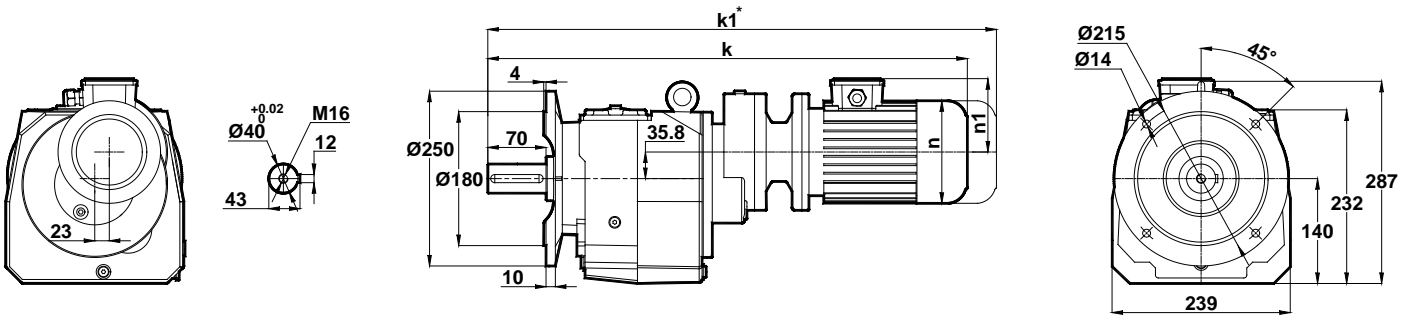

Motor Büyüklüğü / Motor Size / Motorbaugroße	63/B5	71/B5 71/B14	80/B5 80/B14
k	634	631	680
k1	687	751	800
n / n1	121 / 97	138 / 111	156 / 118
m1 (B5)	140	160	200
m1 (B14)	-	105	120

Klemens Kutusu / Terminal Box / Klemmenkasten

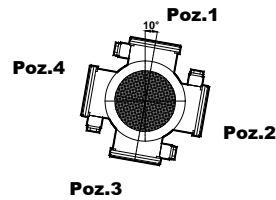

63-71-80

Opsiyonel Flanş Ölçüleri / Optional Flange Dimensions / Auswählbare Flanschabmessungen

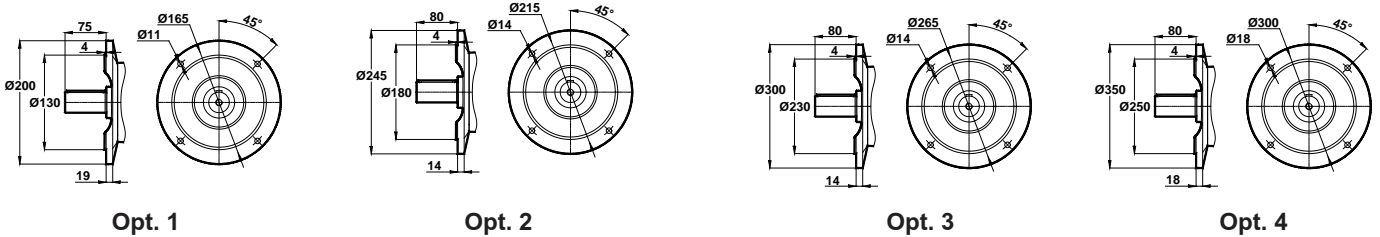

* " k1 " Ölçüsü frenli redüktörlere aittir. 63, 71 tip elektrik motorlu redüktörler soğutmasız, diğerleri soğutmalıdır.
Dimension " k1 " is for motors with brake. Gearboxes with 63 and 71 type electrical motors are not fan cooled, other types are fan cooled.
Maße " k1 " ist für Bremsenmotoren. Getrieben mit 63 und 71 typ Motoren sind ohne Kühlung, andere Typen sind mit Ventilator gekühlt.

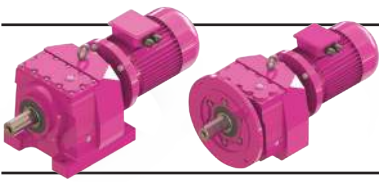

Ölçü Sayfaları

Dimension Pages

Abmessungsseiten



-Mil ucu çektirme deliği DIN 332 sayfa 2 / Tapped center hole to DIN 332, sheet 2 / Zentrierung mit gewinde DIN 332, Blatt 2

MV375

MV376

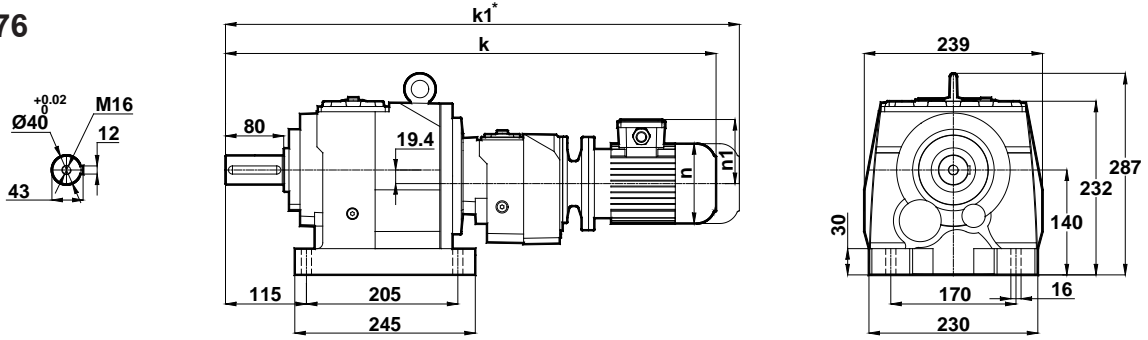

NV375

NV376

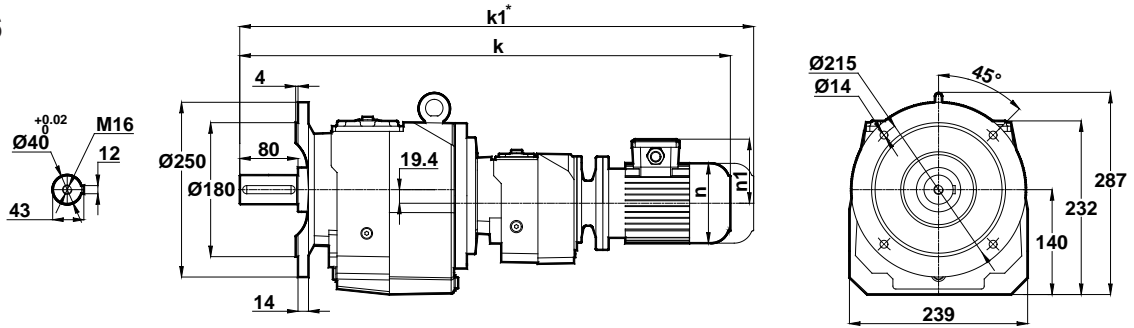

Motor Büyüklüğü / Motor Size / Motorbaugroße	
IEC	63/B5 63/B14
k	700
k1	753
n / n1	121 / 97
m1 (B5)	140
m1 (B14)	90

Klemens Kutusu / Terminal Box / Klemmenkasten

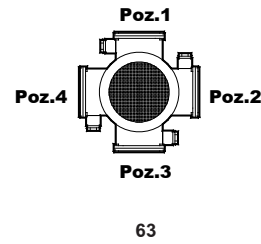

Opsiyonel Flanş Ölçüleri / Optional Flange Dimensions / Auswählbare Flanschabmessungen

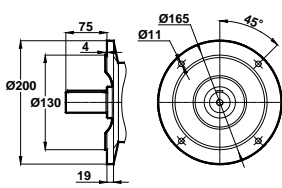

Opt. 1

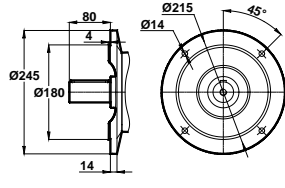

Opt. 2

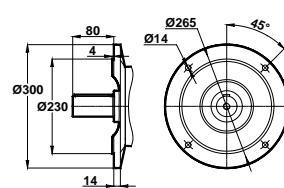

Opt. 3

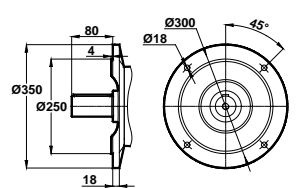

Opt. 4

* " k1 " Ölçüsü frenli redüktörlere aittir. 63, 71 tip elektrik motorlu redüktörler soğutmasız, diğerleri soğutmalıdır.
Dimension " k1 " is for motors with brake. Gearboxes with 63 and 71 type electrical motors are not fan cooled, other types are fan cooled.
Maße " k1 " ist für Bremsenmotoren. Getrieben mit 63 und 71 typ Motoren sind ohne Kühlung, andere Typen zind mit Ventilator gekühlt.

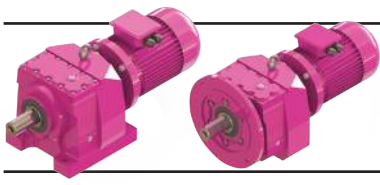

Ölçü Sayfaları Dimension Pages Abmessungsseiten



-Mil ucu çektirme deliği DIN 332 sayfa 2 / Tapped center hole to DIN 332, sheet 2 / Zentrierung mit gewinde DIN 332, Blatt 2

MV472 MV473

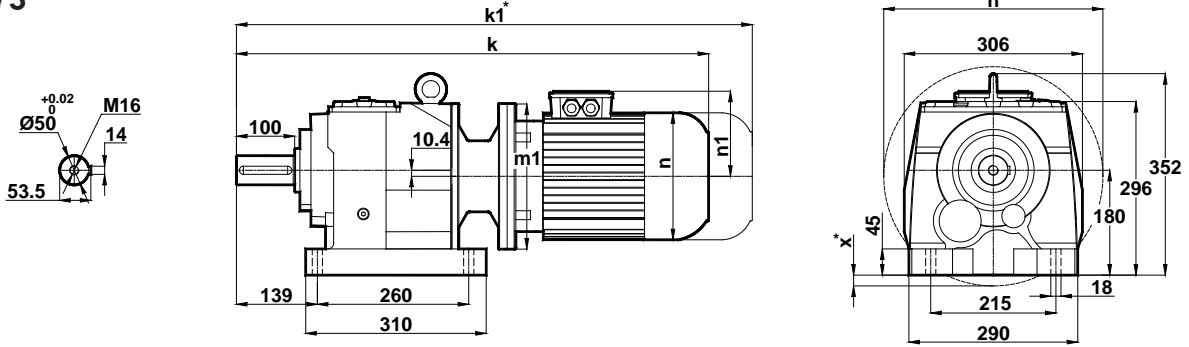

NV472 NV473

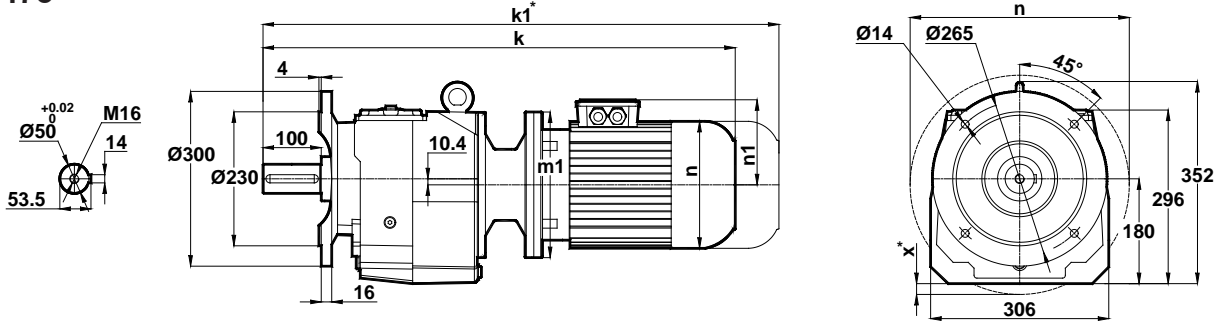

Motor Büyüklüğü / Motor Size / Motorbaugroße											
IEC	80/B5	90S/B5 90S/B14	90L/B5 90L/B14	100L/B5 100L/B14	112M/B5 112M/B14	132S/B5 132S/B14	132M/B5 132M/B14	160M/B5	160L/B5	180M/B5	180L/B5
k	666	686	711	761	781	844	882	1033	1077	1090	1128
k1	786	811	836	896	916	989	1027	1203	1247	1260	1298
n / n1	156 / 118	176 / 126	176 / 126	194 / 135	218 / 146	257 / 168	257 / 168	310 / 225	310 / 225	348 / 241	348 / 241
m1 (B5)	200	200	200	250	250	300	300	350	350	350	350
m1 (B14)	-	140	140	160	160	200	200	-	-	-	-
x (B5)	-	-	-	-	-	-	-	6	6	6	6

Klemens Kutusu / Terminal Box / Klemmenkasten

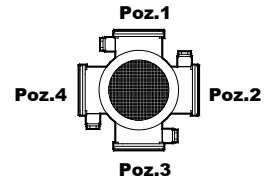

80-90-100-112-132-160-180

Opsiyonel Flanş Ölçüleri / Optional Flange Dimensions / Auswählbare Flanschabmessungen

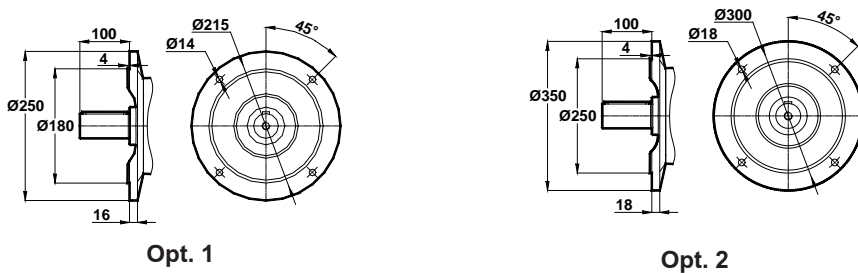

* " k1 " Ölçüsü frenli redüktörlere aittir. 63, 71 tip elektrik motorlu redüktörler soğutmasız, diğerleri soğutmalıdır.
Dimension " k1 " is for motors with brake. Gearboxes with 63 and 71 type electrical motors are not fan cooled, other types are fan cooled.
Maße " k1 " ist für Bremsenmotoren. Getrieben mit 63 und 71 typ Motoren sind ohne Kühlung, andere Typen sind mit Ventilator gekühlt.
x: Motor, ayak bağlantı yüzeyinin altında ise / x: If Motor is lower then foot mounting plane / x: Wenn motor ist niedriger den die Anschlußplatte

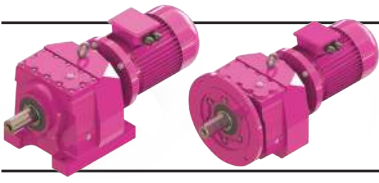

Ölçü Sayfaları Dimension Pages Abmessungenseiten



-Mil ucu çektirme deliği DIN 332 sayfa 2 / Tapped center hole to DIN 332, sheet 2 / Zentrierung mit gewinde DIN 332, Blatt 2

MV474

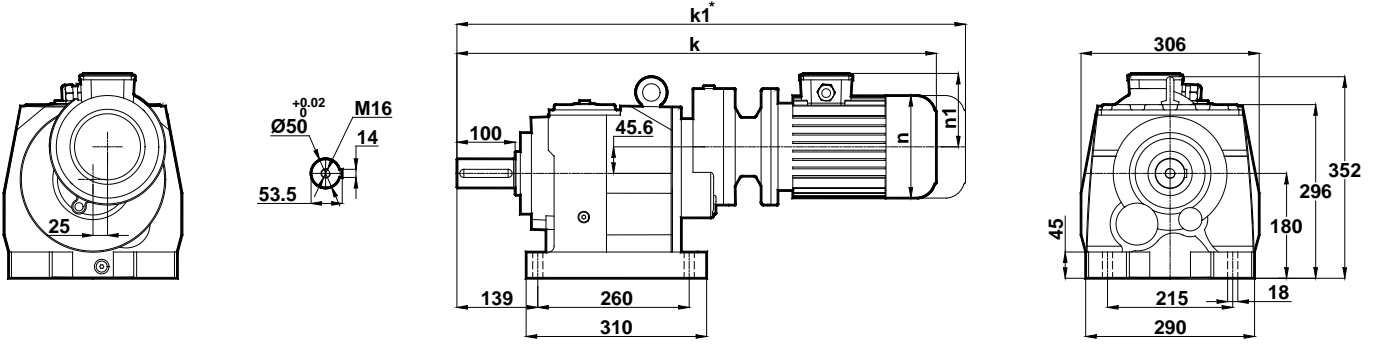

NV474

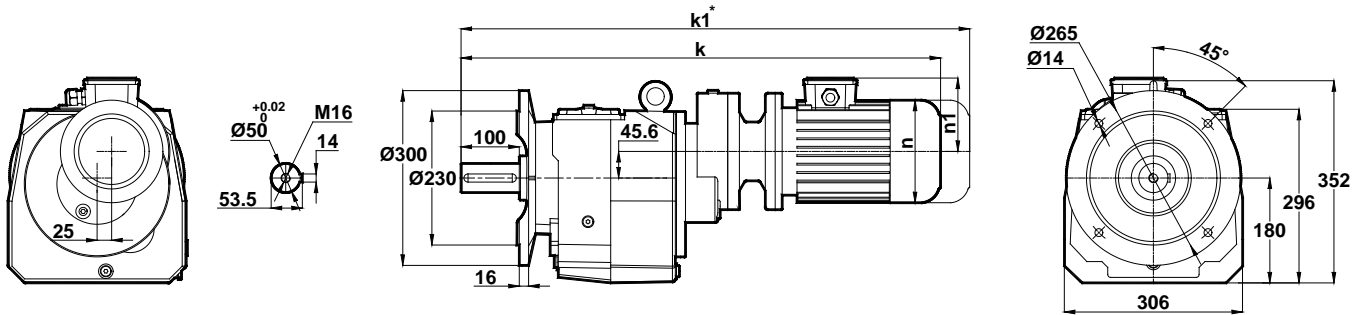

Motor Büyüklüğü / Motor Size / Motorbaugroße		
IEC	71/B5	80/B5 80/B14
k	744	764
k1	864	884
n / n1	138 / 111	156 / 118
m1 (B5)	160	200
m1 (B14)	-	120

Klemens Kutusu / Terminal Box / Klemmenkasten

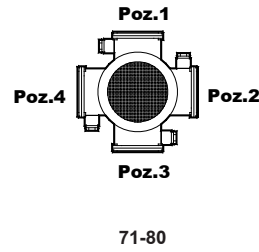

Opsiyonel Flanş Ölçüleri / Optional Flange Dimensions / Auswählbare Flanschabmessungen

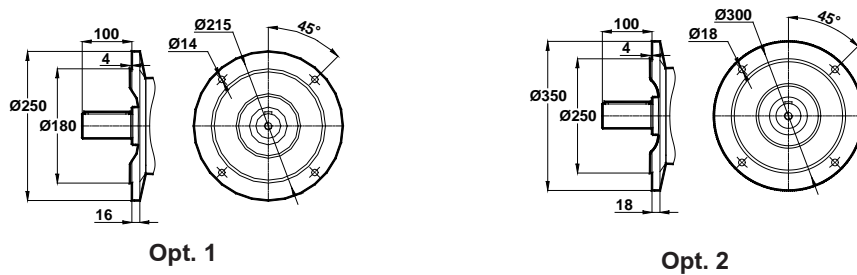

* " k1 " Ölçüsü frenli redüktörlere aittir. 63, 71 tip elektrik motorlu redüktörler soğutmasız, diğerleri soğutmalıdır.
Dimension " k1 " is for motors with brake. Gearboxes with 63 and 71 type electrical motors are not fan cooled, other types are fan cooled.
Maße " k1 " ist für Bremsenmotoren. Getrieben mit 63 und 71 typ Motoren sind ohne Kühlung, andere Typen zind mit Ventilator gekühlt.

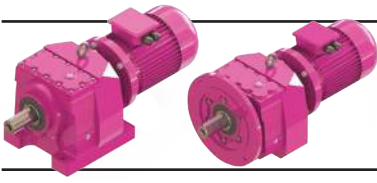

Ölçü Sayfaları Dimension Pages Abmessungsseiten



-Mil ucu çekirme deliği DIN 332 sayfa 2 / Tapped center hole to DIN 332, sheet 2 / Zentrierung mit gewinde DIN 332, Blatt 2

MV475 MV476

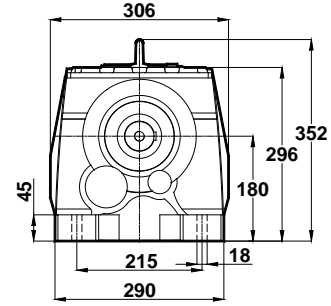
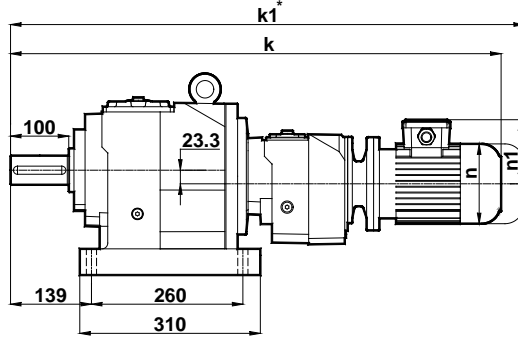
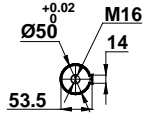

NV475 NV476

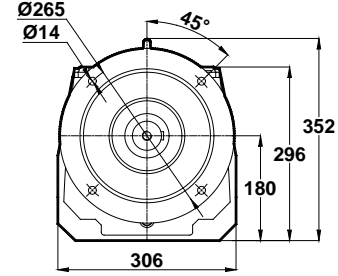
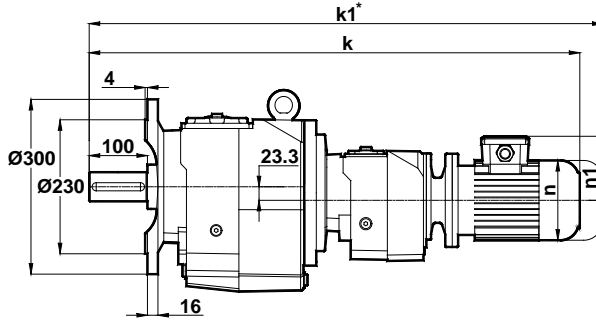
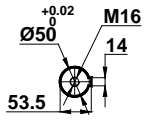

Motor Büyüklüğü / Motor Size / Motorbaugroße		
IEC	63/B5	71/B5 71/B14
k	846	843
k1	899	963
n / n1	121 / 97	138 / 111
m1 (B5)	140	160
m1 (B14)	-	105

Klemens Kutusu / Terminal Box / Klemmenkasten

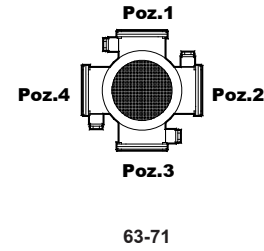

Opsiyonel Flanş Ölçüleri / Optional Flange Dimensions / Auswählbare Flanschabmessungen

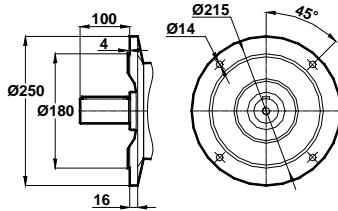

Opt. 1

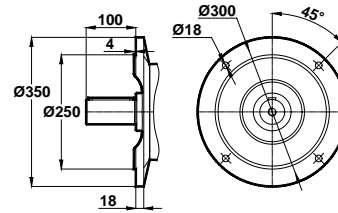

Opt. 2

* " k1 " Ölçüsü frenli redüktörlere aittir. 63, 71 tip elektrik motorlu redüktörler soğutmasız, diğerleri soğutmalıdır.
Dimension " k1 " is for motors with brake. Gearboxes with 63 and 71 type electrical motors are not fan cooled, other types are fan cooled.
Maße " k1 " ist für Bremsenmotoren. Getrieben mit 63 und 71 typ Motoren sind ohne Kühlung, andere Typen zind mit Ventilator gekühlt.

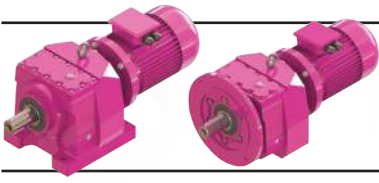

Ölçü Sayfaları Dimension Pages Abmessungsseiten



-Mil ucu çektirme deliği DIN 332 sayfa 2 / Tapped center hole to DIN 332, sheet 2 / Zentrierung mit gewinde DIN 332, Blatt 2

MV572 MV573

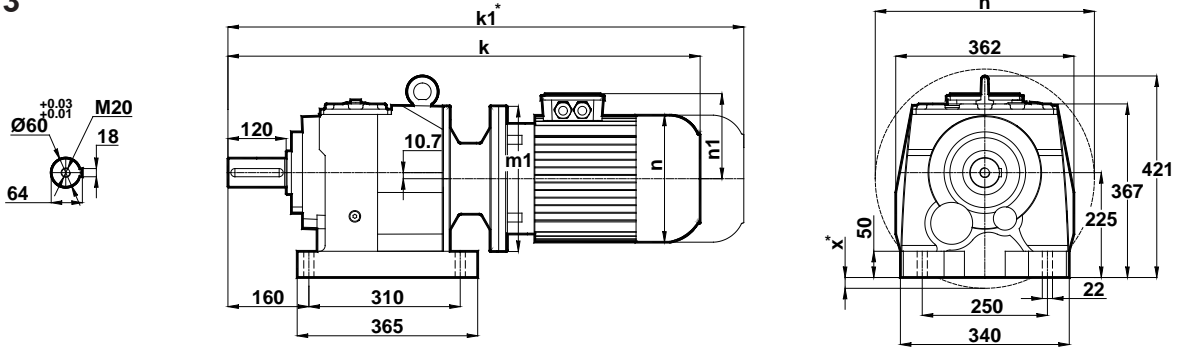

NV572 NV573

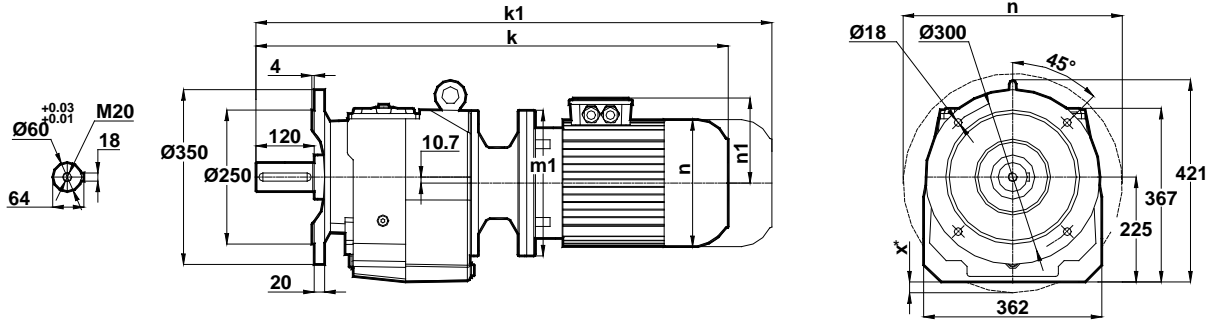

Motor Büyüklüğü / Motor Size / Motorbaugroße									
IEC	100L/B5	112M/B5	132S/B5 132S/B14	132M/B5 132M/B14	160M/B5	160L/B5	180M/B5	180L/B5	200L/B5
k	823	843	908	946	1093	1137	1150	1188	1260
k1	958	978	1053	1091	1263	1307	1320	1358	1460
n / n1	194 / 135	218 / 146	257 / 168	257 / 168	310 / 225	310 / 225	348 / 241	348 / 241	390 / 275
m1 (B5)	250	250	300	300	350	350	350	350	400
m1 (B14)	-	-	200	200	-	-	-	-	-
x (B5)	-	-	-	-	-	-	-	-	-

Klemens Kutusu / Terminal Box / Klemmenkasten

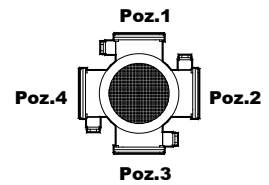

100-112-132-160-180-200

Opsiyonel Flanş Ölçüleri / Optional Flange Dimensions / Auswählbare Flanschabmessungen

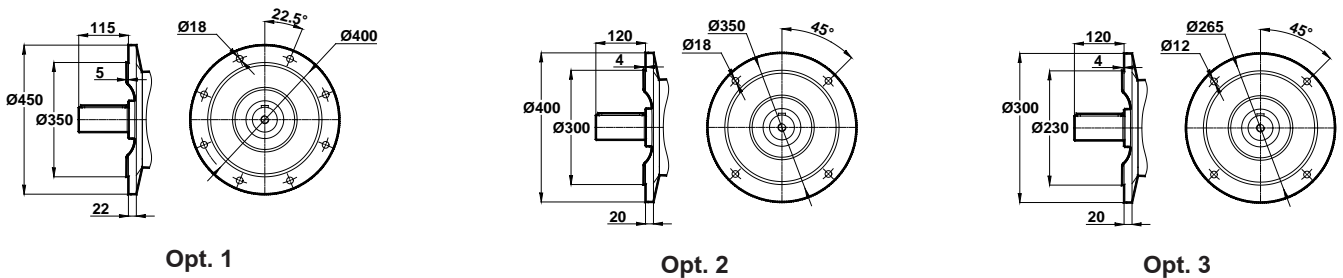

* "k1" Ölçüsü frenli redüktörlere aittir. 63, 71 tip elektrik motorlu redüktörler soğutmasız, diğerleri soğutmalıdır.

Dimension "k1" is for motors with brake. Gearboxes with 63 and 71 type electrical motors are not fan cooled, other types are fan cooled.

Maße "k1" ist für Bremsenmotoren. Getrieben mit 63 und 71 typ Motoren sind ohne Kühlung, andere Typen sind mit Ventilator gekühlt.

x: Motor Ayak bağlantı yüzeyinin altında ise / x: If Motor is lower then foot mounting plane / x: Wenn motor ist niedriger den die Anschlußplatte

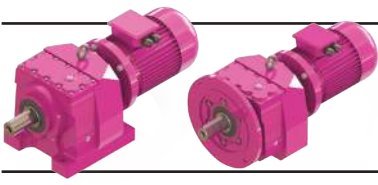

Ölçü Sayfaları

Dimension Pages

Abmessungsseiten



-Mil ucu çekirme deliği DIN 332 sayfa 2 / Tapped center hole to DIN 332, sheet 2 / Zentrierung mit gewinde DIN 332, Blatt 2

MV574

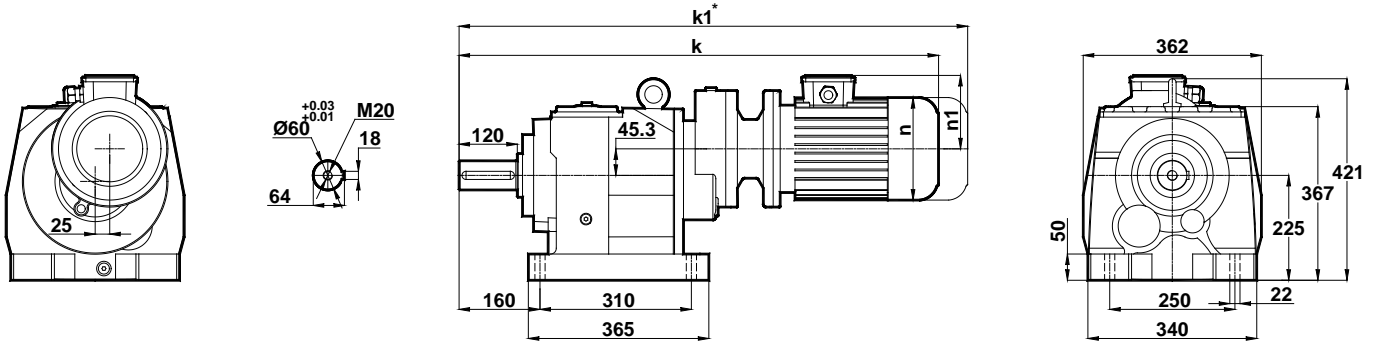

NV574

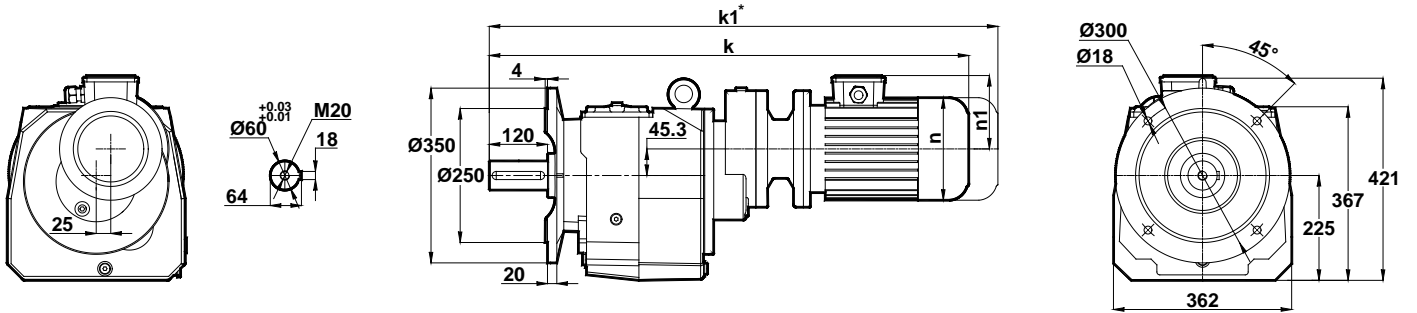

Motor Büyüklüğü / Motor Size / Motorbaugroße				
IEC	71/B5	80/B5 80/B14	90S/B5 90S/B14	90L/B5 90L/B14
k	806	826	846	871
k1	926	946	971	996
n / n1	138 / 111	156 / 118	176 / 126	176 / 126
m1 (B5)	160	200	200	200
m1 (B14)	-	120	140	140

Klemens Kutusu / Terminal Box / Klemmenkasten

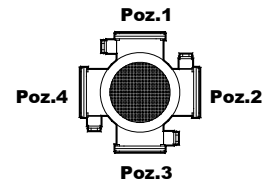

71-80-90

Opsiyonel Flanş Ölçüleri / Optional Flange Dimensions / Auswählbare Flanschabmessungen

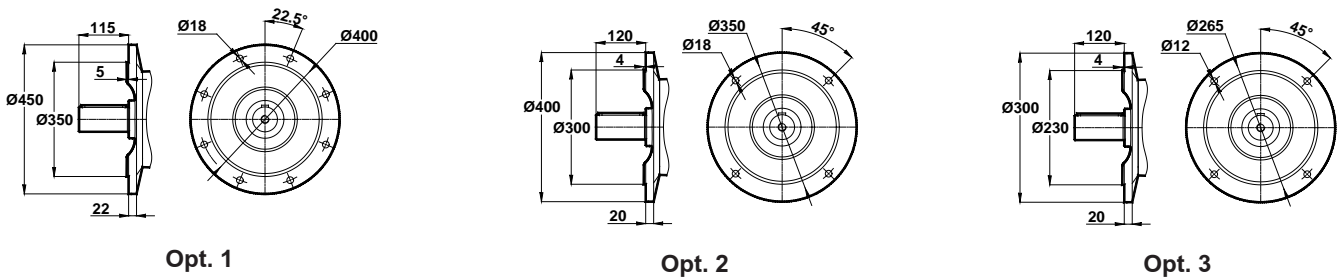

* " k1 " Ölçüsü frenli redüktörlere aittir. 63, 71 tip elektrik motorlu redüktörler soğutmasız, diğerleri soğutmalıdır.
Dimension " k1 " is for motors with brake. Gearboxes with 63 and 71 type electrical motors are not fan cooled, other types are fan cooled.
Maße " k1 " ist für Bremsenmotoren. Getrieben mit 63 und 71 typ Motoren sind ohne Kühlung, andere Typen sind mit Ventilator gekühlt.

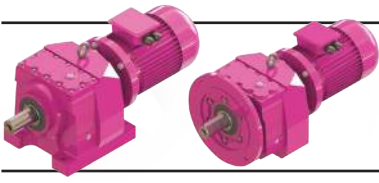

Ölçü Sayfaları Dimension Pages Abmessungsseiten



-Mil ucu çektirme deliği DIN 332 sayfa 2 / Tapped center hole to DIN 332, sheet 2 / Zentrierung mit gewinde DIN 332, Blatt 2

MV575 MV576

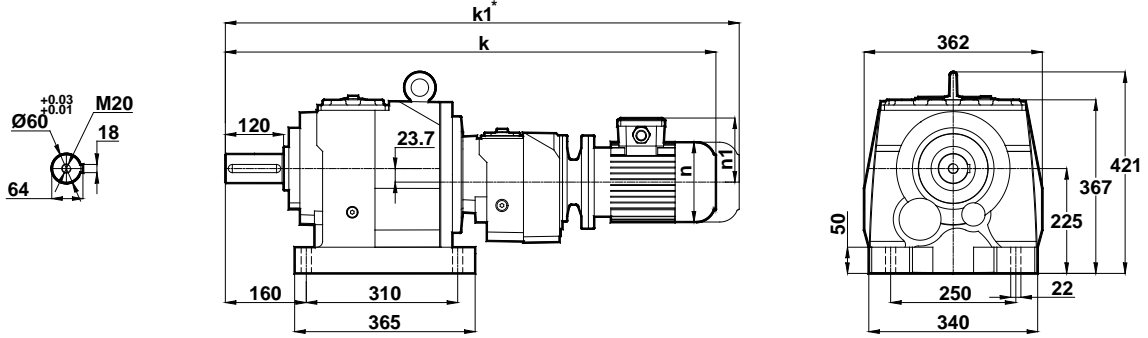

NV575 NV576

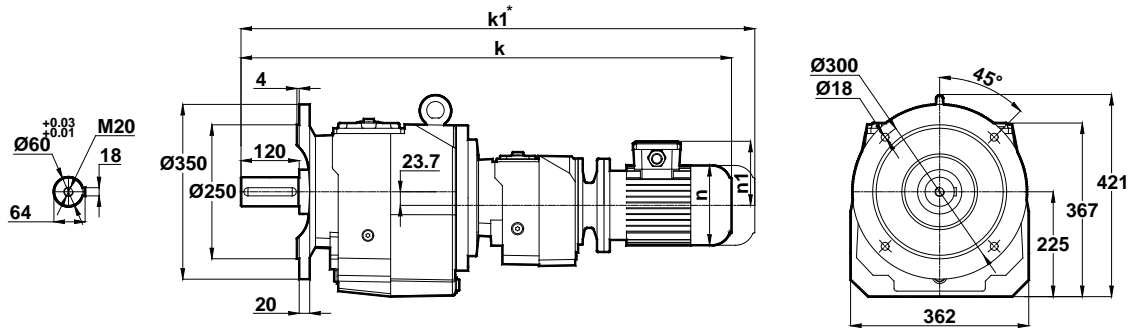

Motor Büyüklüğü / Motor Size / Motorbaugroße		
IEC	63/B5	71/B5 71/B14
k	910	907
k1	963	1027
n / n1	121 / 97	138 / 111
m1 (B5)	140	160
m1 (B14)	-	105

Klemens Kutusu / Terminal Box / Klemmenkasten

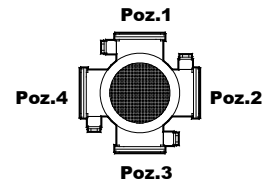

63-71

Opsiyonel Flanş Ölçüleri / Optional Flange Dimensions / Auswählbare Flanschabmessungen

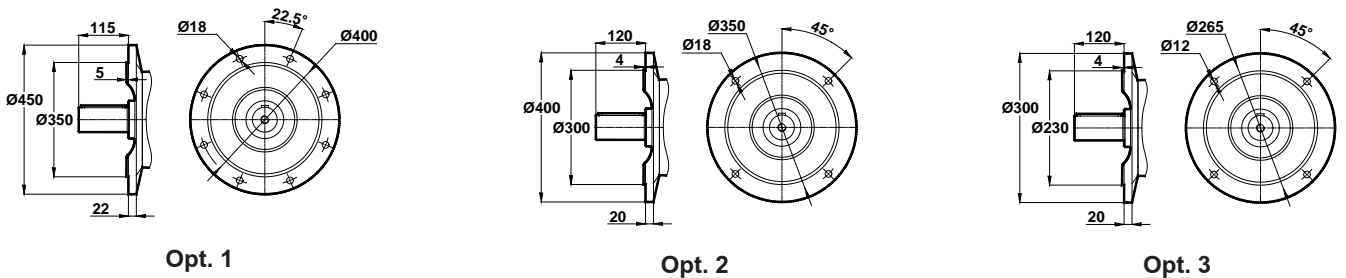

* " k1 " Ölçüsü frenli redüktörlere aittir. 63, 71 tip elektrik motorlu redüktörler soğutmasız, diğerleri soğutmalıdır.
Dimension " k1 " is for motors with brake. Gearboxes with 63 and 71 type electrical motors are not fan cooled, other types are fan cooled.
Maße " k1 " ist für Bremsenmotoren. Getrieben mit 63 und 71 typ Motoren sind ohne Kühlung, andere Typen zind mit Ventilator gekühlt.

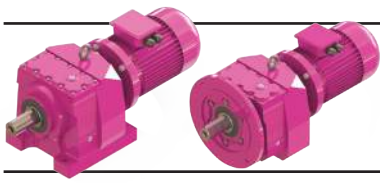

Ölçü Sayfaları Dimension Pages Abmessungsseiten



-Mil ucu çektirme deliği DIN 332 sayfa 2 / Tapped center hole to DIN 332, sheet 2 / Zentrierung mit gewinde DIN 332, Blatt 2

MV672 MV673

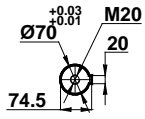
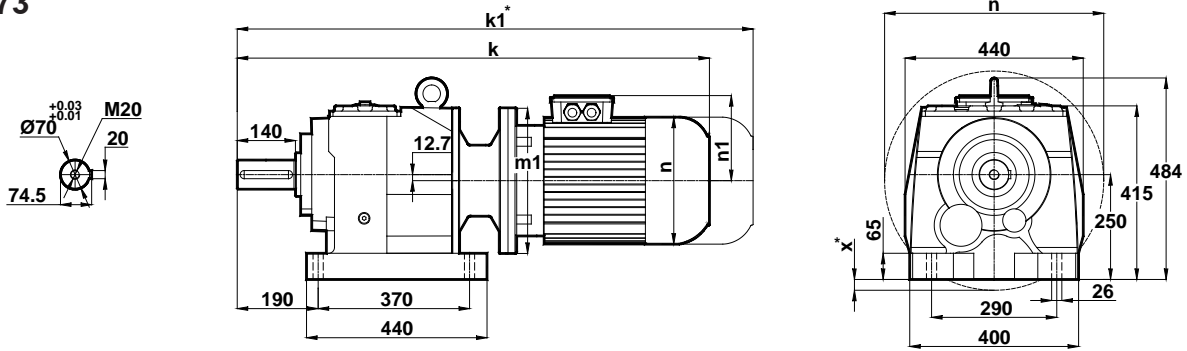

NV672 NV673

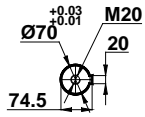
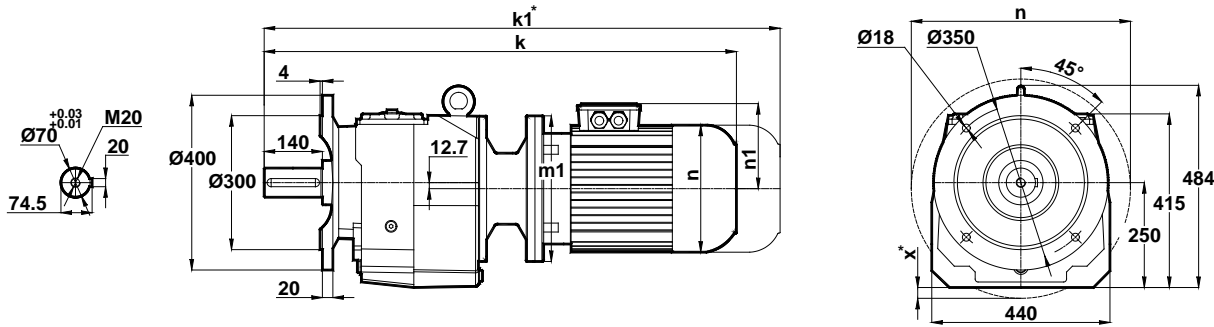

Motor Büyüklüğü / Motor Size / Motorbaugroße										
IEC	112M/B5	132S/B5 132S/B14	132M/B5 132M/B14	160M/B5	160L/B5	180M/B5	180L/B5	200L/B5	225S/B5	225M/B5
k	904	963	1001	1148	1192	1205	1243	1315	1386	1411
k1	1039	1108	1146	1318	1362	1375	1413	1515	1576	-
n / n1	218 / 146	257 / 168	257 / 168	310 / 225	310 / 225	348 / 241	348 / 241	390 / 275	434 / 285	434 / 285
m1 (B5)	250	300	300	350	350	350	350	400	450	450
m1 (B14)	-	200	200	-	-	-	-	-	-	-
x (B5)	-	-	-	-	-	-	-	-	-	-

Klemens Kutusu / Terminal Box / Klemmenkasten

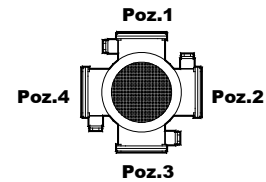

112-132-160-180-200-225

Opsiyonel Flanş Ölçüleri / Optional Flange Dimensions / Auswählbare Flanschabmessungen

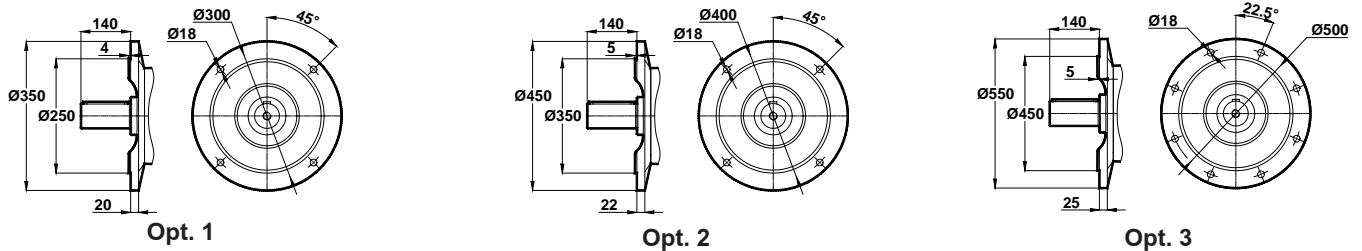

* " k1 " Ölçüsü frenli redüktörlere aittir. 63, 71 tip elektrik motorlu redüktörler soğutmasız, diğerleri soğutmalıdır.
Dimension " k1 " is for motors with brake. Gearboxes with 63 and 71 type electrical motors are not fan cooled, other types are fan cooled.
Maße " k1 " ist für Bremsenmotoren. Getrieben mit 63 und 71 typ Motoren sind ohne Kühlung, andere Typen sind mit Ventilator gekühlt.
x: Motor, ayak bağlantı yüzeyinin altında ise / x: If Motor is lower then foot mounting plane / x: Wenn motor ist niedriger den die Anschlußplatte

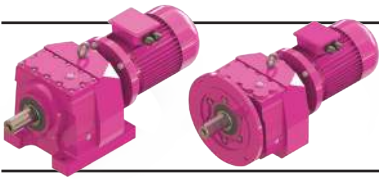

Ölçü Sayfaları

Dimension Pages

Abmessungsseiten



-Mil ucu çektirme deliği DIN 332 sayfa 2 / Tapped center hole to DIN 332, sheet 2 / Zentrierung mit gewinde DIN 332, Blatt 2

MV674

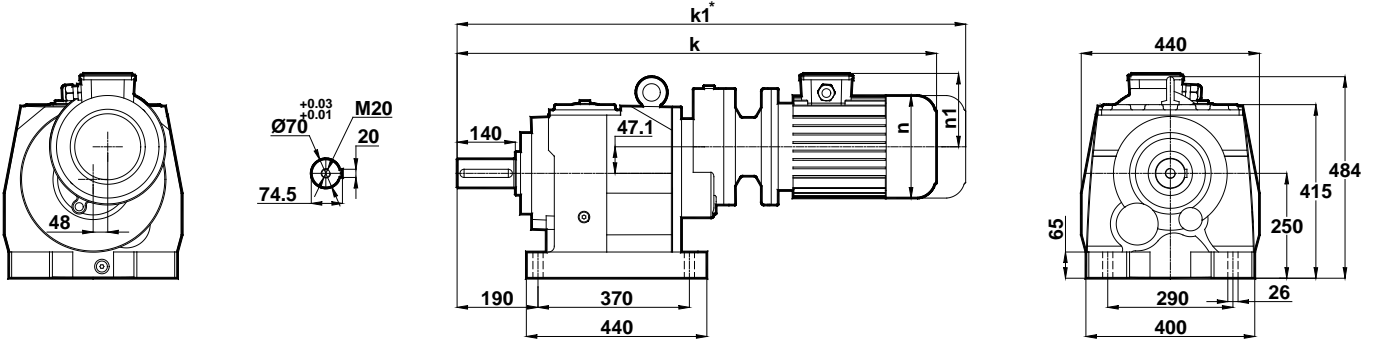

NV674

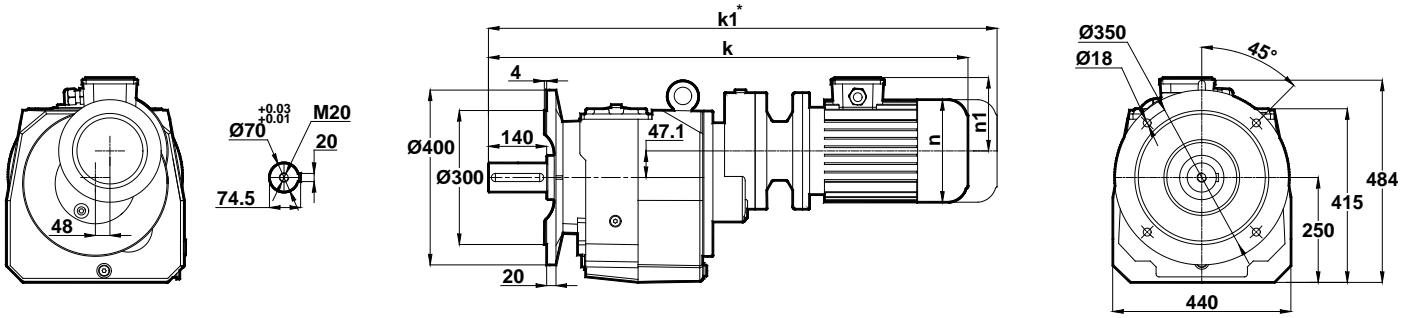

Motor Büyüklüğü / Motor Size / Motorbaugroße			
IEC	80/B5	90S/B5 90S/B14	90L/B5 90L/B14
k	897	917	942
k1	1017	1042	1067
n / n1	156 / 118	176 / 126	176 / 126
m1 (B5)	200	200	200
m1 (B14)	-	140	140

Klemens Kutusu / Terminal Box / Klemmenkasten

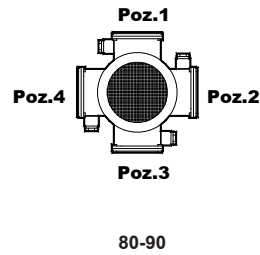

Opsiyonel Flanş Ölçüleri / Optional Flange Dimensions / Auswählbare Flanschabmessungen

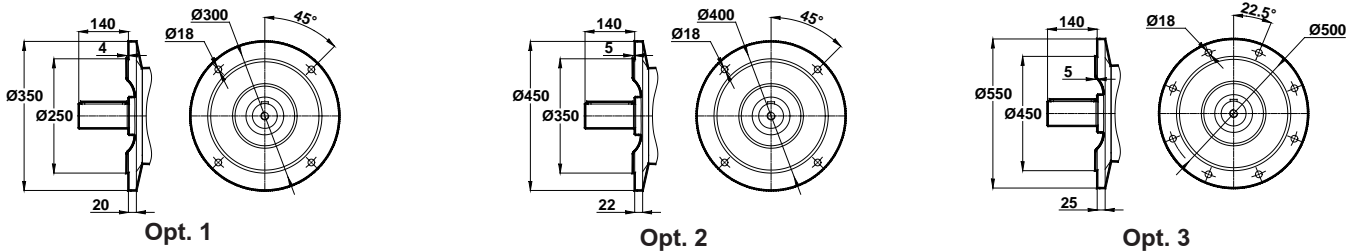

* "k1" Ölçüsü frenli redüktörlere aittir. 63, 71 tip elektrik motorlu redüktörler soğutmasız, diğerleri soğutmalıdır.
Dimension "k1" is for motors with brake. Gearboxes with 63 and 71 type electrical motors are not fan cooled, other types are fan cooled.
Maße "k1" ist für Bremsenmotoren. Getrieben mit 63 und 71 typ Motoren sind ohne Kühlung, andere Typen sind mit Ventilator gekühlt.

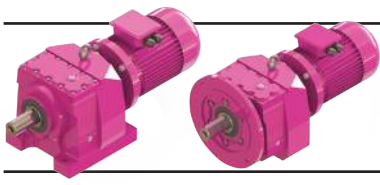

Ölçü Sayfaları Dimension Pages Abmessungenseiten



-Mil ucu çektirme deliği DIN 332 sayfa 2 / Tapped center hole to DIN 332, sheet 2 / Zentrierung mit gewinde DIN 332, Blatt 2

MV675 MV676

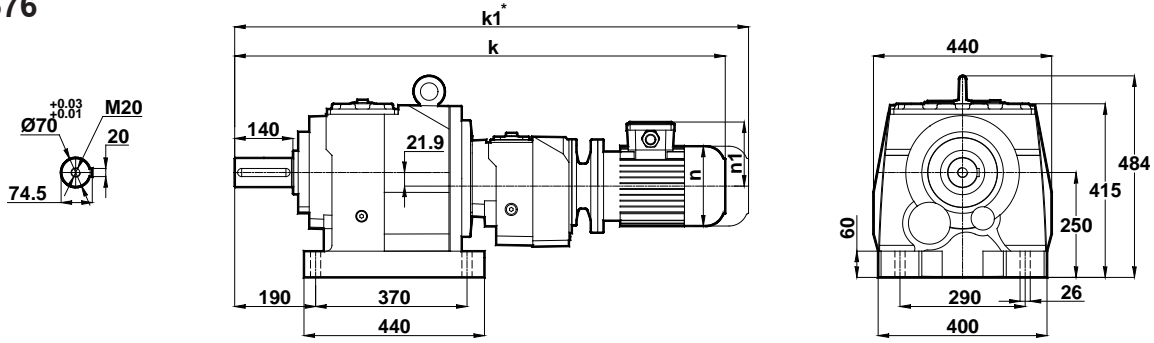

NV675 NV676

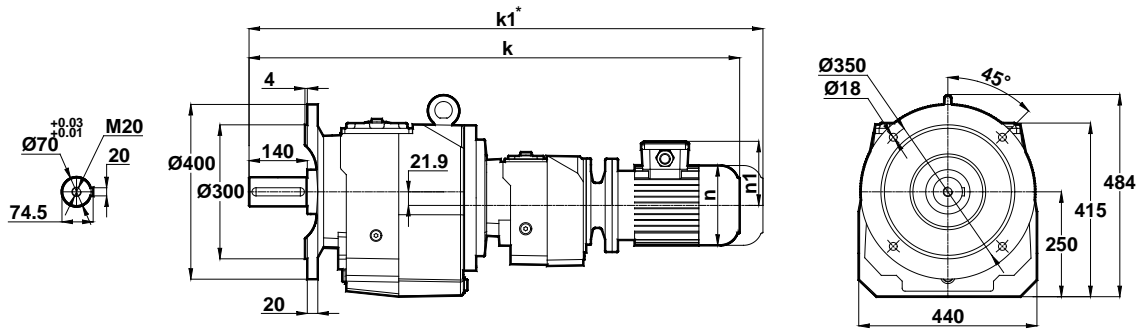

Motor Büyüklüğü / Motor Size / Motorbaugroße	71/B5	80/B5 80/B14
IEC	71/B5	80/B5 80/B14
k	1027	1047
k1	1147	1167
n / n1	138 / 111	156 / 118
m1 (B5)	160	200
m1 (B14)	-	120

Klemens Kutusu / Terminal Box / Klemmenkasten

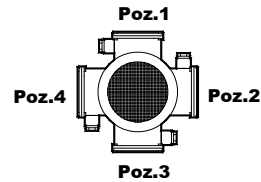

71-80

Opsiyonel Flanş Ölçüleri / Optional Flange Dimensions / Auswählbare Flanschabmessungen

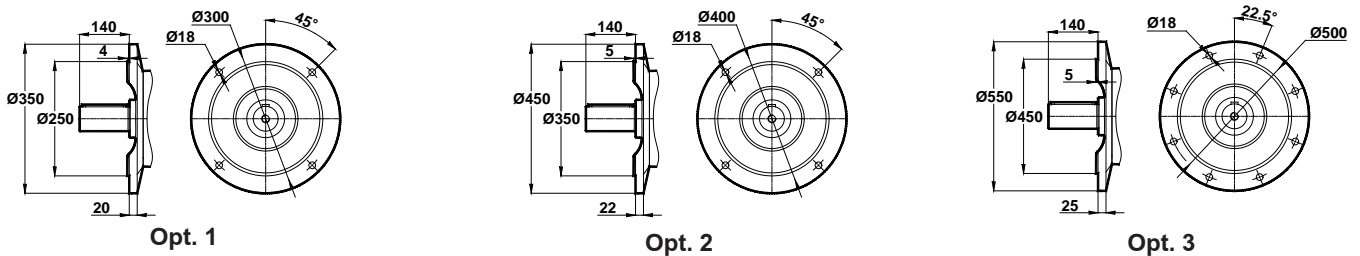

* " k1 " Ölçüsü frenli redüktörlere aittir. 63, 71 tip elektrik motorlu redüktörler soğutmasız, diğerleri soğutmalıdır.
Dimension " k1 " is for motors with brake. Gearboxes with 63 and 71 type electrical motors are not fan cooled, other types are fan cooled.
Maße " k1 " ist für Bremsenmotoren. Getrieben mit 63 und 71 typ Motoren sind ohne Kühlung, andere Typen sind mit Ventilator gekühlt.

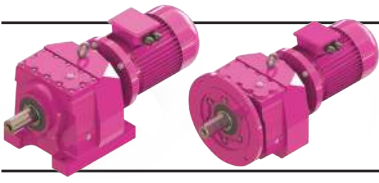

Ölçü Sayfaları Dimension Pages Abmessungsseiten



-Mil ucu çektirme deliği DIN 332 sayfa 2 / Tapped center hole to DIN 332, sheet 2 / Zentrierung mit gewinde DIN 332, Blatt 2

MV772 MV773

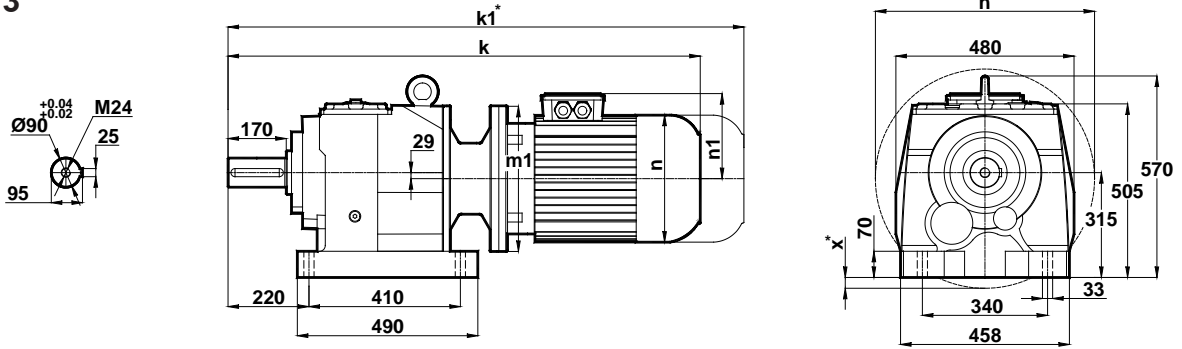

NV772 NV773

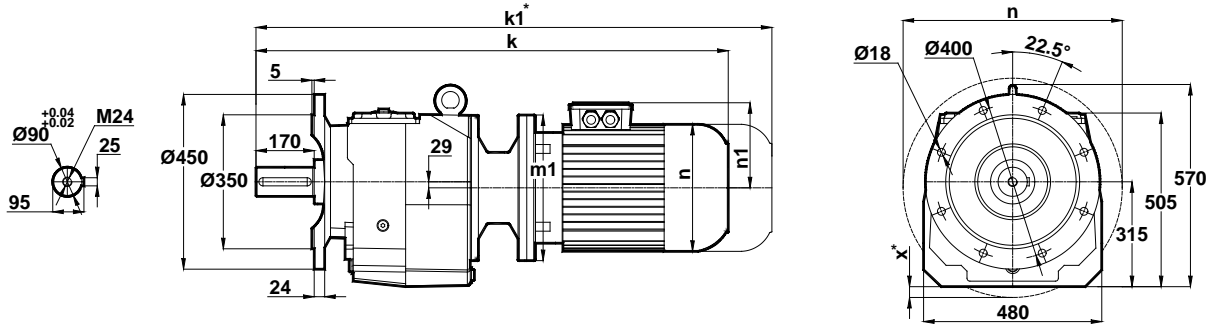

Motor Büyüklüğü / Motor Size / Motorbaugroße										
IEC	132S/B5	132M/B5	160M/B5	160L/B5	180M/B5	180L/B5	200L/B5	225S/B5	225M/B5	250M/B5
k	1048	1086	1227	1271	1284	1322	1396	1467	1492	1568
k1	1193	1231	1397	1441	1454	1492	1596	1657	-	-
n / n1	257 / 168	257 / 168	310 / 225	310 / 225	348 / 241	348 / 241	434 / 285	434 / 285	434 / 285	480 / 322
m1 (B5)	300	300	350	350	350	350	400	450	450	550
m1 (B14)	-	-	-	-	-	-	-	-	-	-
x (B5)	-	-	-	-	-	-	-	-	-	-

Klemens Kutusu / Terminal Box / Klemmenkasten

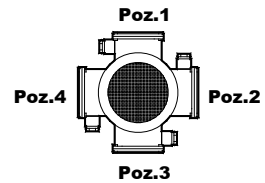

132-160-180-200-225-250

Opsiyonel Flanş Ölçüleri / Optional Flange Dimensions / Auswählbare Flanschabmessungen

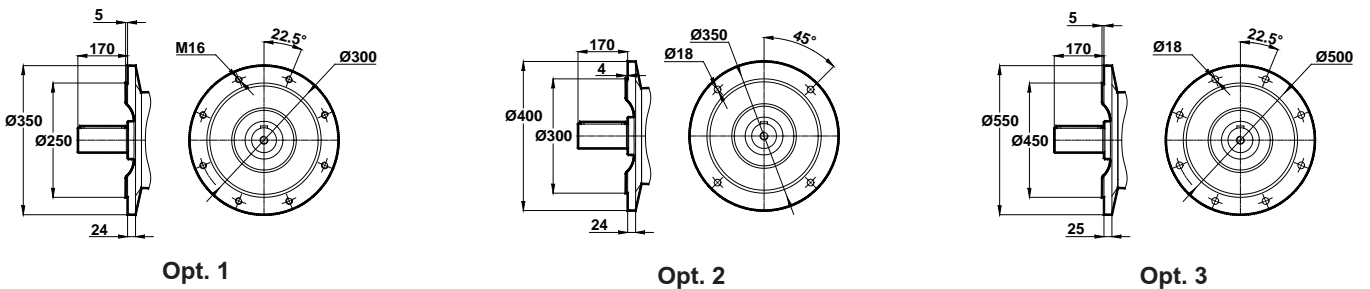

* "k1" Ölçüsü frenli redüktörlere aittir. 63, 71 tip elektrik motorlu redüktörler soğutmasız, diğerleri soğutmalıdır.

Dimension "k1" is for motors with brake. Gearboxes with 63 and 71 type electrical motors are not fan cooled, other types are fan cooled.

Maße "k1" ist für Bremsenmotoren. Getrieben mit 63 und 71 typ Motoren sind ohne Kühlung, andere Typen sind mit Ventilator gekühlt.

x: Motor Ayak bağlantı yüzeyinin altında ise / x: If Motor is lower than foot mounting plane / x: Wenn motor ist niedriger den die Anschlußplatte

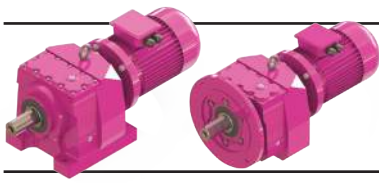

Ölçü Sayfaları

Dimension Pages

Abmessungsseiten



-Mil ucu çekirme deliği DIN 332 sayfa 2 / Tapped center hole to DIN 332, sheet 2 / Zentrierung mit gewinde DIN 332, Blatt 2

MV774

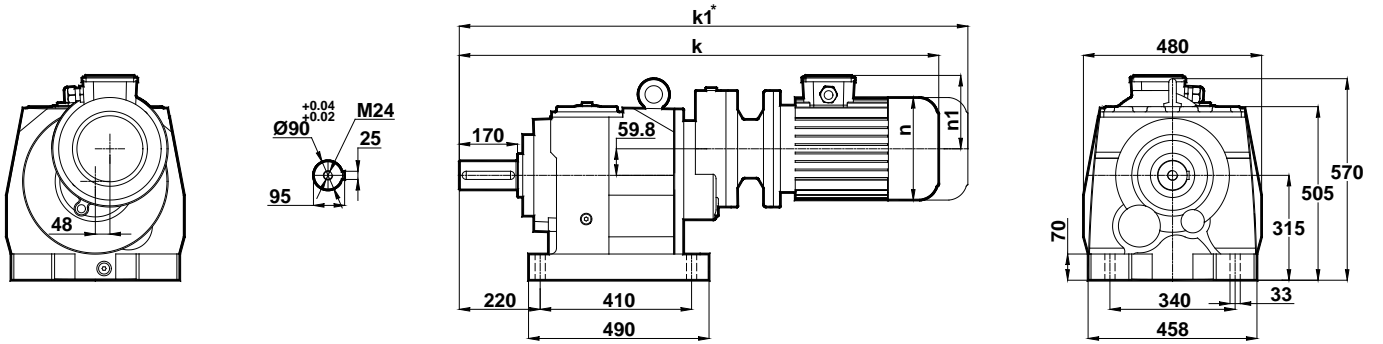

NV774

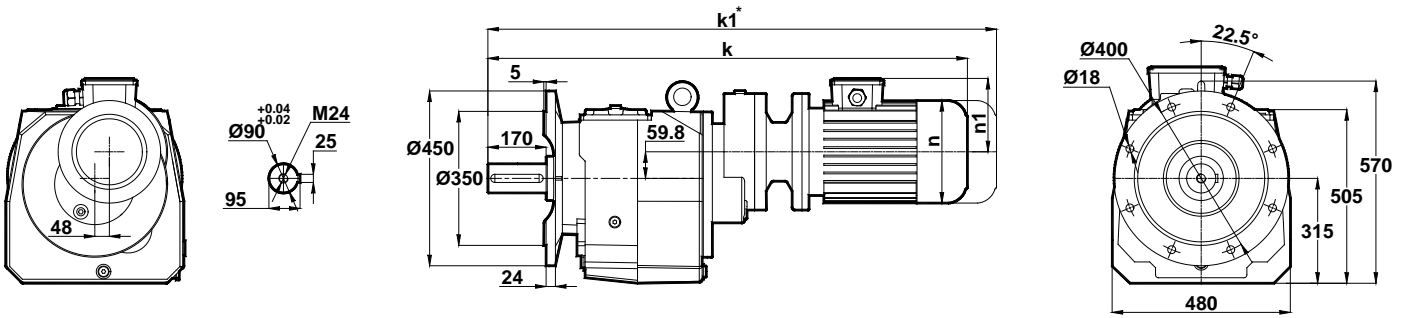

Motor Büyüklüğü / Motor Size / Motorbaugroße				
IEC	80/B5	90S/B5 90S/B14	90L/B5 90L/B14	100L/B5 100L/B14
k	982	1002	1027	1077
k1	1102	1127	1152	1212
n / n1	156 / 118	176 / 126	176 / 126	194 / 135
m1 (B5)	200	200	200	250
m1 (B14)	-	140	140	160

Klemens Kutusu / Terminal Box / Klemmenkasten

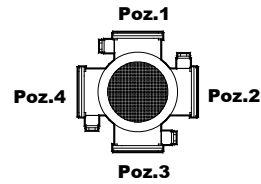

80-90-100

Opsiyonel Flanş Ölçüleri / Optional Flange Dimensions / Auswählbare Flanschabmessungen

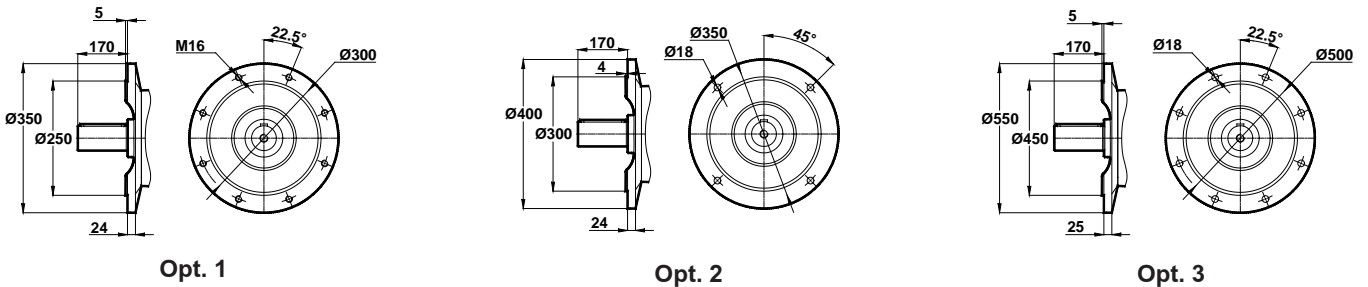

* " k1 " Ölçüsü frenli redüktörlere aittir. 63, 71 tip elektrik motorlu redüktörler soğutmasız, diğerleri soğutmalıdır.
Dimension " k1 " is for motors with brake. Gearboxes with 63 and 71 type electrical motors are not fan cooled, other types are fan cooled.
Maße " k1 " ist für Bremsenmotoren. Getrieben mit 63 und 71 typ Motoren sind ohne Kühlung, andere Typen sind mit Ventilator gekühlt.

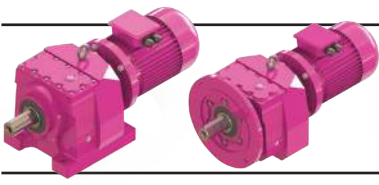

Ölçü Sayfaları Dimension Pages Abmessungsseiten



-Mil ucu çektirme deliği DIN 332 sayfa 2 / Tapped center hole to DIN 332, sheet 2 / Zentrierung mit gewinde DIN 332, Blatt 2

MV775 MV776

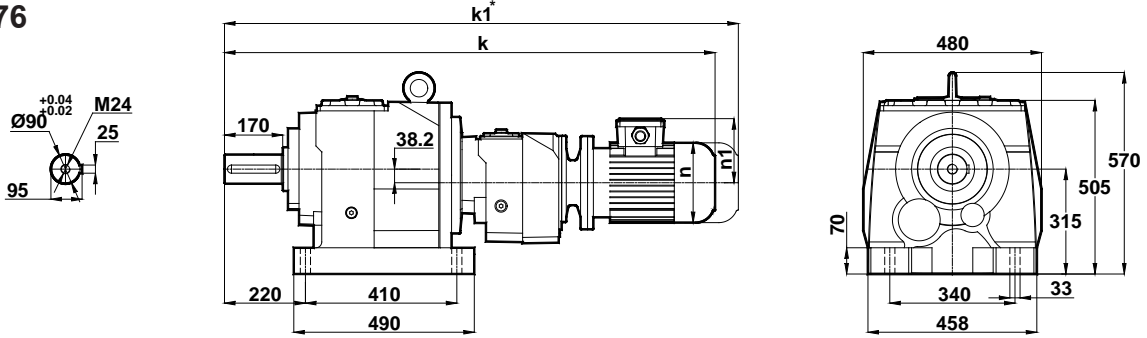

NV775 NV776

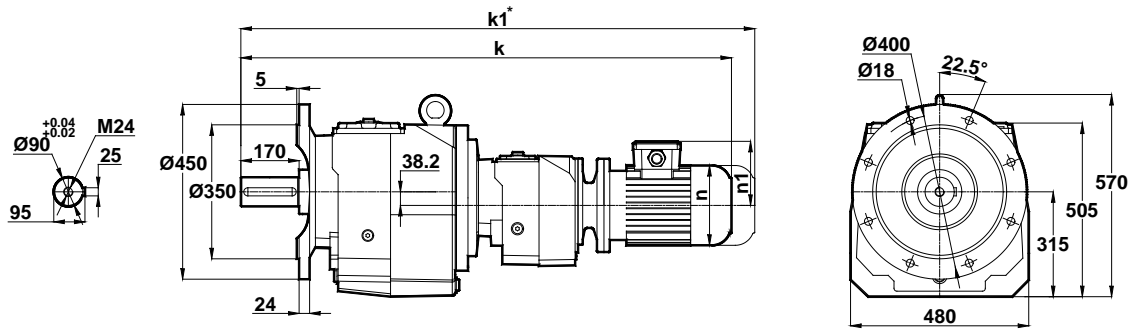

Motor Büyüklüğü / Motor Size / Motorbaugroße				
IEC	71/B5	80/B5 80/B14	90S/B5 90S/B14	90L/B5 90L/B14
k	1115	1135	1155	1180
k1	1235	1255	1280	1305
n / n1	138 / 111	156 / 118	176 / 126	176 / 126
m1 (B5)	160	200	200	200
m1 (B14)	-	120	140	140

Klemens Kutusu / Terminal Box / Klemmenkasten

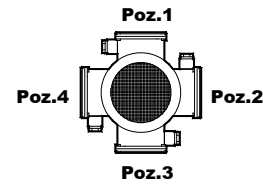

71-80-90

Opsiyonel Flanş Ölçüleri / Optional Flange Dimensions / Auswählbare Flanschabmessungen

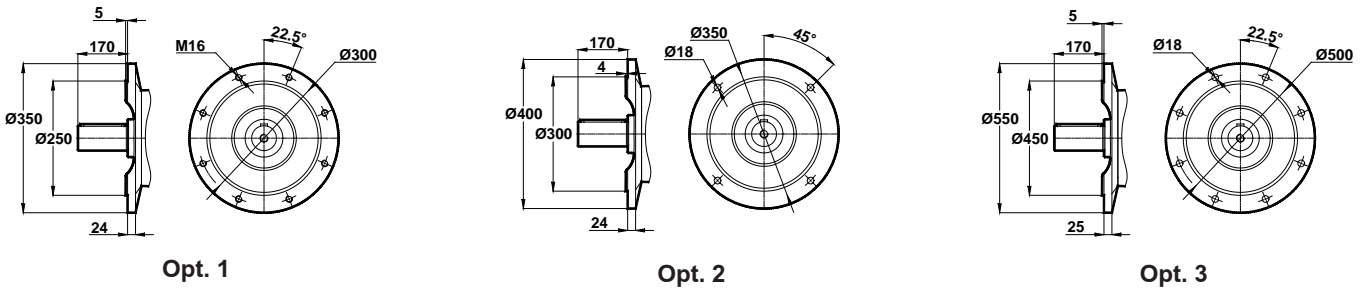

Opt. 1

Opt. 2

Opt. 3

* " k1 " Ölçüsü frenli redüktörlere aittir. 63, 71 tip elektrik motorlu redüktörler soğutmasız, diğerleri soğutmalıdır.

Dimension " k1 " is for motors with brake. Gearboxes with 63 and 71 type electrical motors are not fan cooled, other types are fan cooled.

Maße " k1 " ist für Bremsenmotoren. Getrieben mit 63 und 71 typ Motoren sind ohne Kühlung, andere Typen sind mit Ventilator gekühlt.

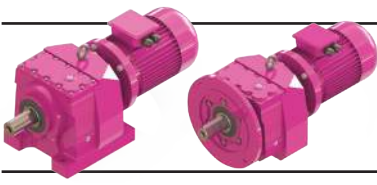

Ölçü Sayfaları Dimension Pages Abmessungsseiten



-Mil ucu çekirme deliği DIN 332 sayfa 2 / Tapped center hole to DIN 332, sheet 2 / Zentrierung mit gewinde DIN 332, Blatt 2

MV872 MV873

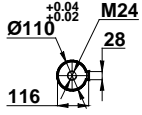
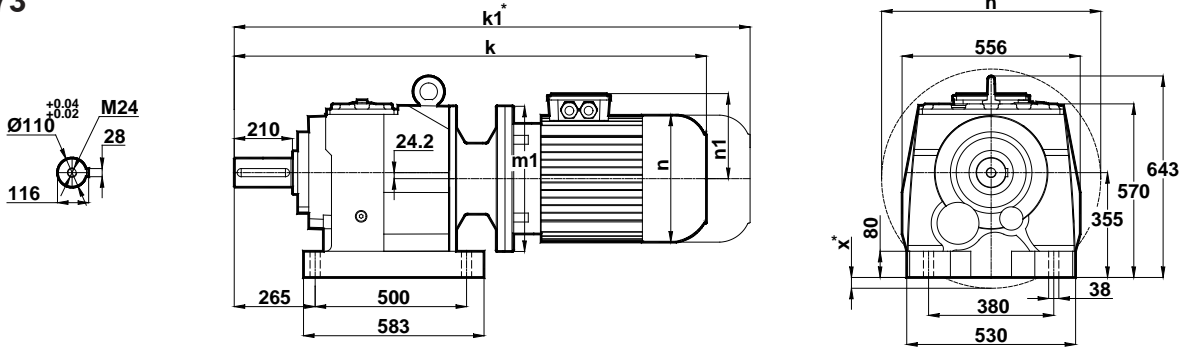

NV872 NV873

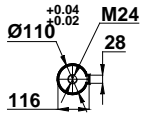
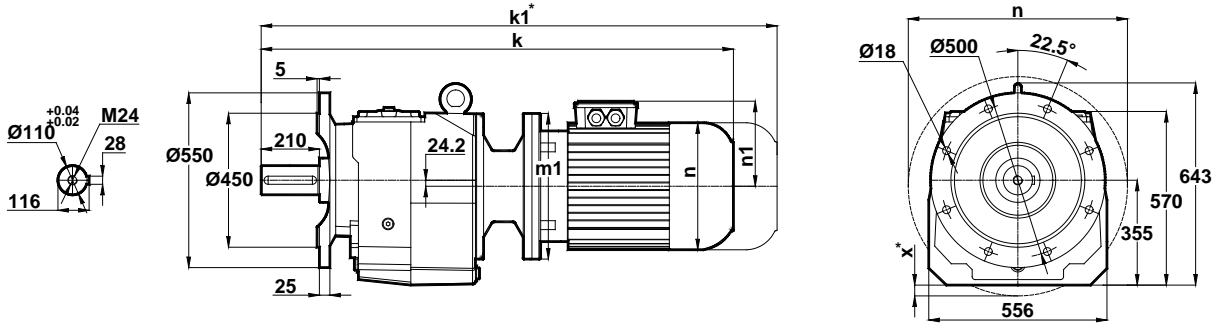

Klemens Kutusu / Terminal Box / Klemmenkasten

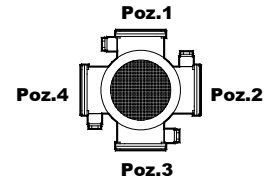

160-180-200-225-250-280

Motor Büyüklüğü / Motor Size / Motorbaugroße										
IEC	160M/B5	160L/B5	180M/B5	180L/B5	200L/B5	225S/B5	225M/B5	250M/B5	280S/B5	280M/B5
k	1413	1457	1470	1508	1560	1578	1603	1679	1741	1740
k1	1583	1627	1640	1678	1760	1768	-	-	-	-
n / n1	310 / 225	310 / 225	348 / 241	348 / 241	390 / 275	434 / 285	434 / 285	480 / 322	544 / 350	544 / 350
m1 (B5)	350	350	350	350	400	450	450	550	550	550
m1 (B14)	-	-	-	-	-	-	-	-	-	-
x (B5)	-	-	-	-	-	-	-	-	-	-

Opsiyonel Flanş Ölçüleri / Optional Flange Dimensions / Auswählbare Flanschabmessungen

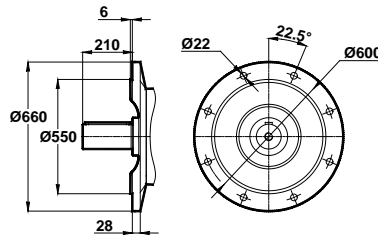

Opt. 1

* " k1 " Ölçüsü frenli redüktörlere aittir. 63, 71 tip elektrik motorlu redüktörler soğutmasız, diğerleri soğutmalıdır.

Dimension " k1 " is for motors with brake. Gearboxes with 63 and 71 type electrical motors are not fan cooled, other types are fan cooled.

Maße " k1 " ist für Bremsenmotoren. Getrieben mit 63 und 71 typ Motoren sind ohne Kühlung, andere Typen sind mit Ventilator gekühlt.

x: Motor, ayak bağlantı yüzeyinin altında ise / x: If Motor is lower then foot mounting plane / x: Wenn motor ist niedriger den die Anschlußplatte

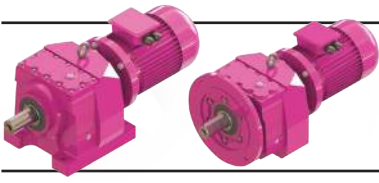

Ölçü Sayfaları Dimension Pages Abmessungenseiten



-Mil ucu çektirme deliği DIN 332 sayfa 2 / Tapped center hole to DIN 332, sheet 2 / Zentrierung mit gewinde DIN 332, Blatt 2

MV874

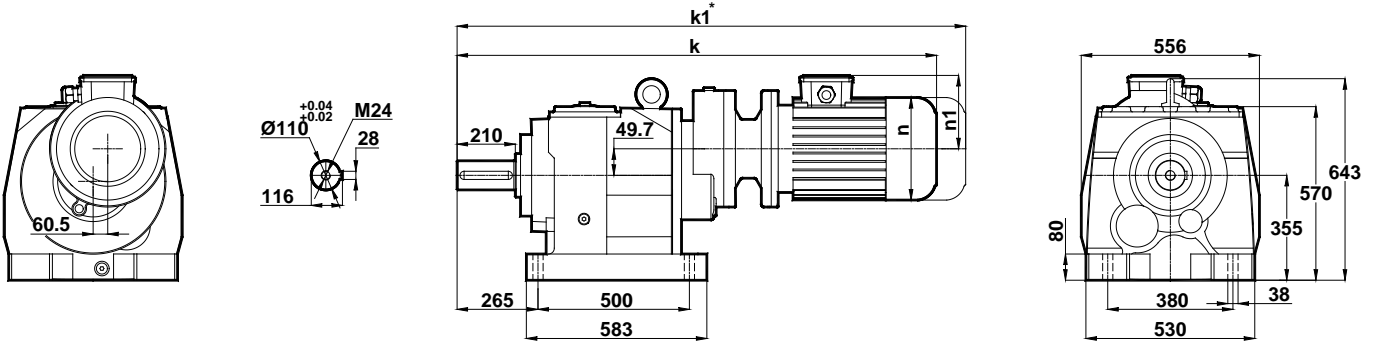

NV874

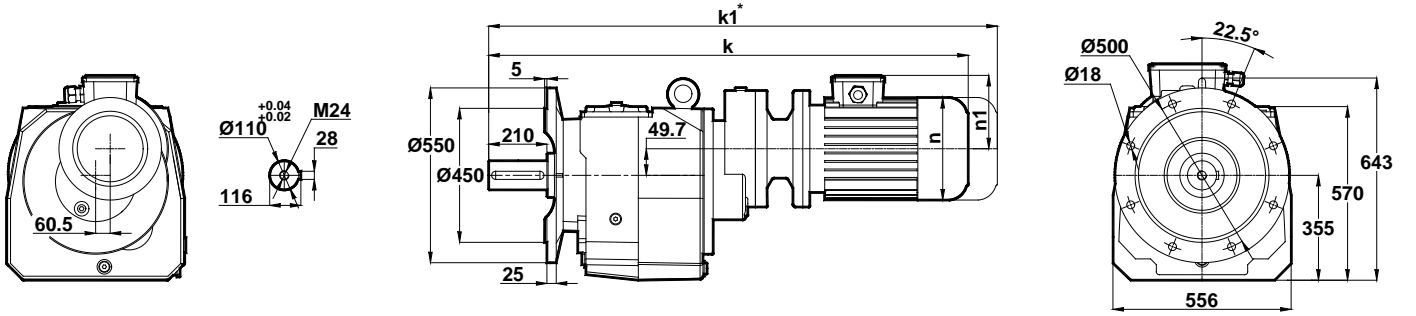

Motor Büyüklüğü / Motor Size / Motorbaugroße				
IEC	100L/B5	112M/B5	132S/B5 132S/B14	132M/B5 132M/B14
k	1212	1232	1297	1335
k1	1347	1367	1442	1480
n / n1	194 / 135	218 / 146	257 / 168	257 / 168
m1 (B5)	250	250	300	300
m1 (B14)	-	-	200	200

Klemens Kutusu / Terminal Box / Klemmenkasten

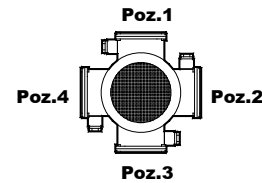

100-112-132

Opsiyonel Flanş Ölçüleri / Optional Flange Dimensions / Auswählbare Flanschabmessungen

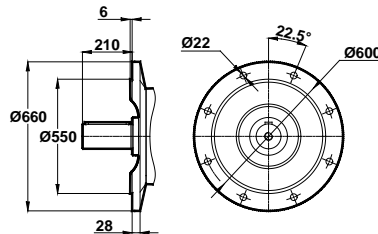

Opt. 1

* " k1 " Ölçüsü frenli redüktörlere aittir. 63, 71 tip elektrik motorlu redüktörler soğutmasız, diğerleri soğutmalıdır.

Dimension " k1 " is for motors with brake. Gearboxes with 63 and 71 type electrical motors are not fan cooled, other types are fan cooled.

Maße " k1 " ist für Bremsenmotoren. Getrieben mit 63 und 71 typ Motoren sind ohne Kühlung, andere Typen sind mit Ventilator gekühlt.

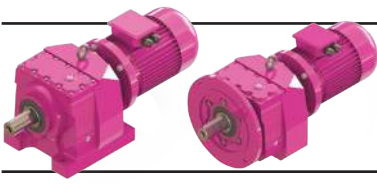

Ölçü Sayfaları Dimension Pages Abmessungsseiten



-Mil ucu çekirme deliği DIN 332 sayfa 2 / Tapped center hole to DIN 332, sheet 2 / Zentrierung mit gewinde DIN 332, Blatt 2

MV875 MV876

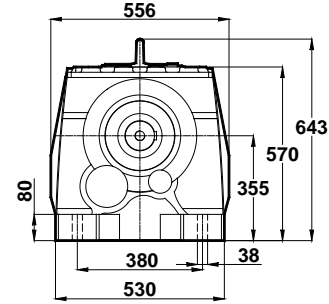
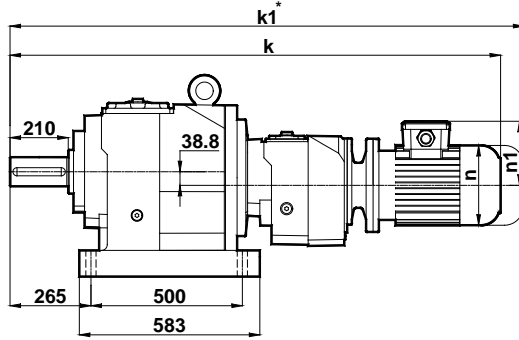
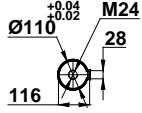

NV875 NV876

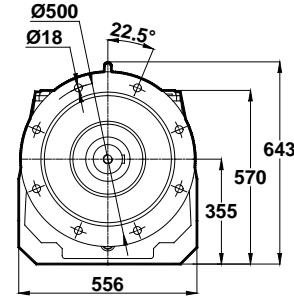
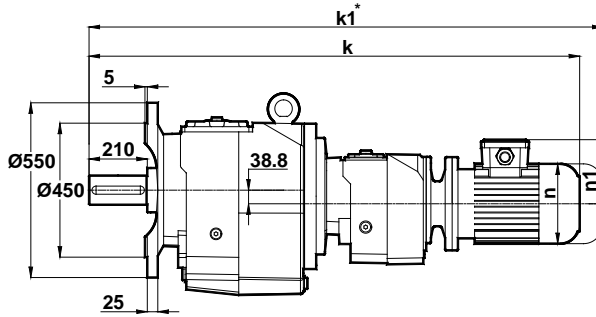
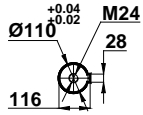

Motor Büyüklüğü / Motor Size / Motorbaugroße					
IEC	71/B5	80/B5 80/B14	90S/B5 90S/B14	90L/B5 90L/B14	100L/B5 100L/B14
k	1232	1252	1272	1297	1346
k1	1352	1372	1397	1422	1481
n / n1	138 / 111	156 / 118	176 / 126	176 / 126	194 / 135
m1 (B5)	160	200	200	200	250
m1 (B14)	-	120	140	140	160

Klemens Kutusu / Terminal Box / Klemmenkasten

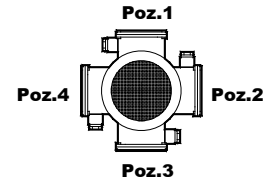

71-80-90-100

Opsiyonel Flanş Ölçüleri / Optional Flange Dimensions / Auswählbare Flanschabmessungen

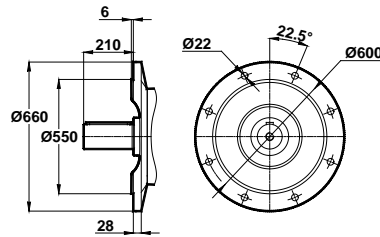

Opt. 1

* " k1 " Ölçüsü frenli redüktörlere aittir. 63, 71 tip elektrik motorlu redüktörler soğutmasız, diğerleri soğutmalıdır.
Dimension " k1 " is for motors with brake. Gearboxes with 63 and 71 type electrical motors are not fan cooled, other types are fan cooled.
Maße " k1 " ist für Bremsenmotoren. Getrieben mit 63 und 71 typ Motoren sind ohne Kühlung, andere Typen sind mit Ventilator gekühlt.

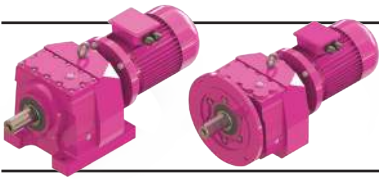

Ölçü Sayfaları Dimension Pages Abmessungsseiten



-Mil ucu çektirme deliği DIN 332 sayfa 2 / Tapped center hole to DIN 332, sheet 2 / Zentrierung mit gewinde DIN 332, Blatt 2

MV972 MV973

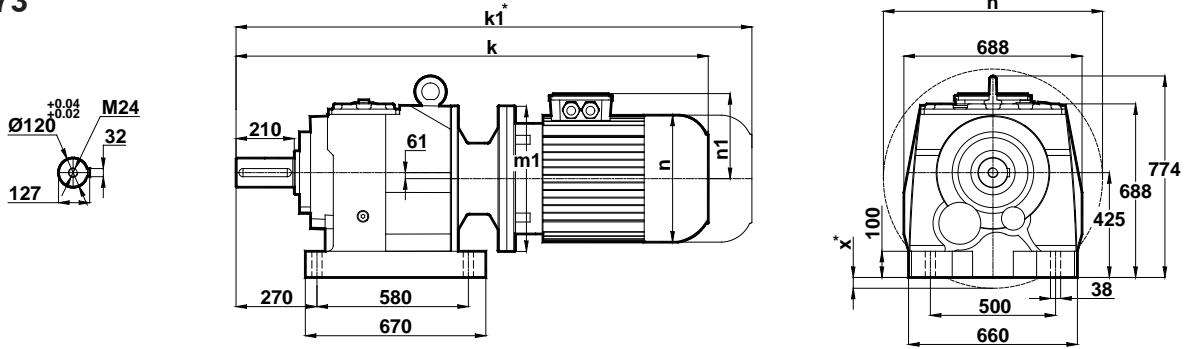

NV972 NV973

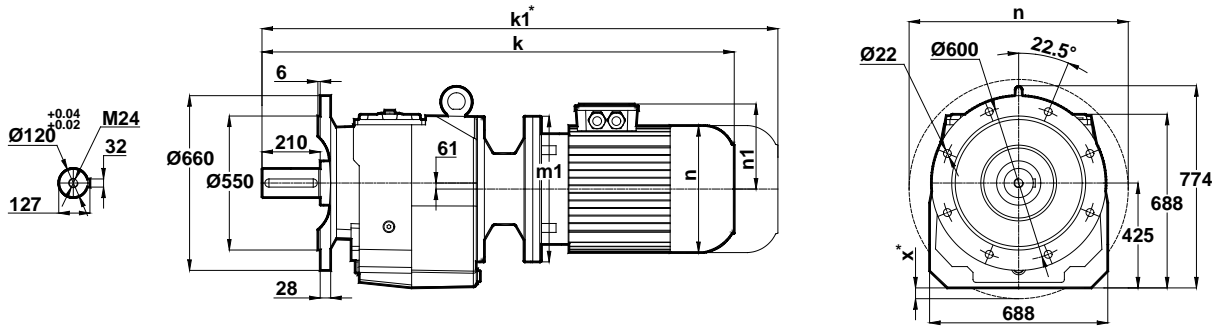

Motor Büyüklüğü / Motor Size / Motorbaugroße												
IEC	160M/B5	160L/B5	180M/B5	180L/B5	200L/B5	225S/B5	225M/B5	250M/B5	280S/B5	280M/B5	315S/4	315M/4
k	1401	1445	1458	1496	1572	1632	1657	1785	1847	1847	2059	2059
k1	1571	1615	1628	1666	1772	1822	1842	-	-	-	-	-
n / n1	310 / 225	310 / 225	348 / 241	348 / 241	390 / 275	434 / 285	434 / 285	480 / 322	544 / 350	544 / 350	614 / 510	614 / 510
m1 (B5)	350	350	350	350	400	450	450	550	550	550	660	660
m1 (B14)	-	-	-	-	-	-	-	-	-	-	-	-
x (B5)	-	-	-	-	-	-	-	-	-	-	-	-

Klemens Kutusu / Terminal Box / Klemmenkasten

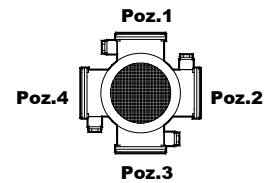

160-180-200-225-250-280-315

* " k1 " Ölçüsü frenli redüktörlere aittir. 63, 71 tip elektrik motorlu redüktörler soğutmasız, diğerleri soğutmalıdır.

Dimension " k1 " is for motors with brake. Gearboxes with 63 and 71 type electrical motors are not fan cooled, other types are fan cooled.

Maße " k1 " ist für Bremsenmotoren. Getrieben mit 63 und 71 typ Motoren sind ohne Kühlung, andere Typen sind mit Ventilator gekühlt.

x: Motor Ayak bağlantı yüzeyinin altında ise / x: If Motor is lower then foot mounting plane / x: Wenn motor ist niedriger den die Anschlußplatte

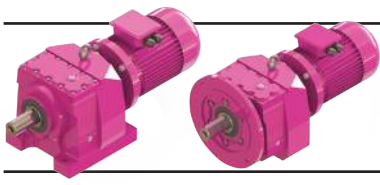

Ölçü Sayfaları

Dimension Pages

Abmessungsseiten



-Mil ucu çekirme deliği DIN 332 sayfa 2 / Tapped center hole to DIN 332, sheet 2 / Zentrierung mit gewinde DIN 332, Blatt 2

MV974

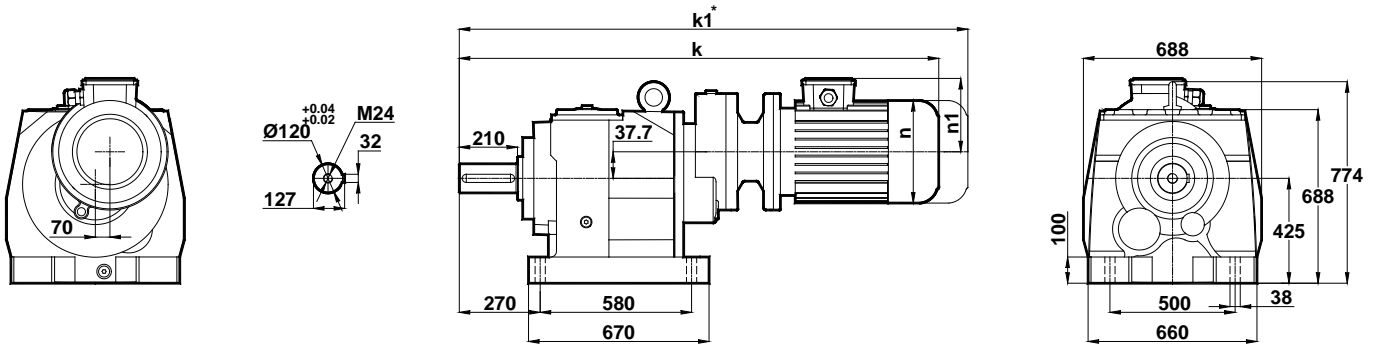

NV974

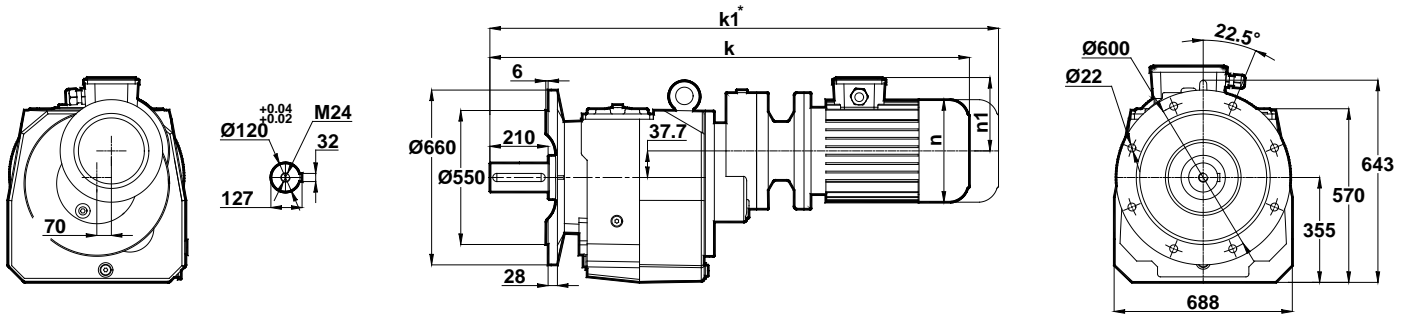

Motor Büyüklüğü / Motor Size / Motorbaugroße				
IEC	100L/B5	112M/B5	132S/B5 132S/B14	132M/B5 132M/B14
k	1316	1336	1395	1433
k1	1451	1471	1540	1578
n / n1	194 / 135	218 / 146	257 / 168	257 / 168
m1 (B5)	250	250	300	300
m1 (B14)	-	-	200	200

Klemens Kutusu / Terminal Box / Klemmenkasten

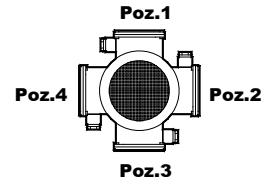

100-112-132

* " k1 " Ölçüsü frenli redüktörlere aittir. 63, 71 tip elektrik motorlu redüktörler soğutmasız, diğerleri soğutmalıdır.
Dimension " k1 " is for motors with brake. Gearboxes with 63 and 71 type electrical motors are not fan cooled, other types are fan cooled.
Maße " k1 " ist für Bremsenmotoren. Getrieben mit 63 und 71 typ Motoren sind ohne Kühlung, andere Typen sind mit Ventilator gekühlt.

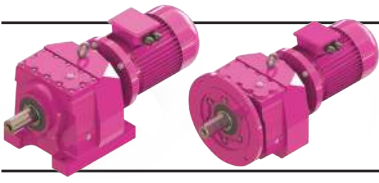

Ölçü Sayfaları Dimension Pages Abmessungsseiten



-Mil ucu çekirtme deliği DIN 332 sayfa 2 / Tapped center hole to DIN 332, sheet 2 / Zentrierung mit gewinde DIN 332, Blatt 2

MV975 MV976

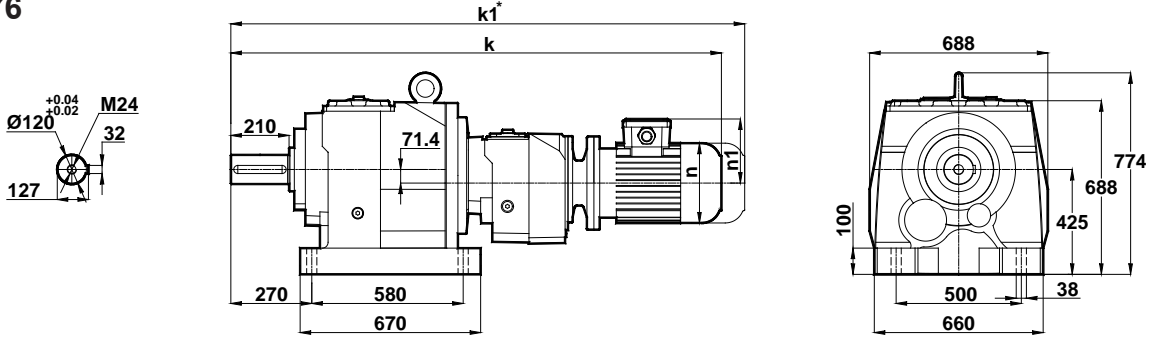

NV975 NV976

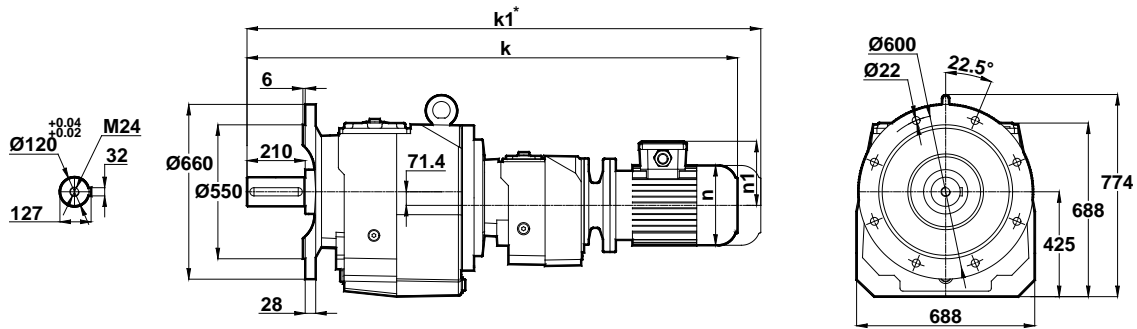

Motor Büyüklüğü / Motor Size / Motorbaugroße						
IEC	80/B5	90S/B5 90S/B14	90L/B5 90L/B14	100L/B5 100L/B14	112M/B5 112M/B14	132S/B5 132S/B14
k	1375	1395	1420	1470	1490	1553
k1	1495	1520	1545	1605	1625	1698
n / n1	156 / 118	176 / 126	176 / 126	194 / 135	218 / 146	218 / 146
m1 (B5)	200	200	200	250	250	300
m1 (B14)	-	140	140	160	160	200

Klemens Kutusu / Terminal Box / Klemmenkasten

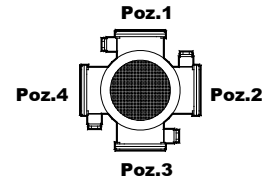

80-90-100-112-132

* "k1" Ölçüsü frenli redüktörlere aittir. 63, 71 tip elektrik motorlu redüktörler soğutmasız, diğerleri soğutmalıdır.
Dimension "k1" is for motors with brake. Gearboxes with 63 and 71 type electrical motors are not fan cooled, other types are fan cooled.
Maße "k1" ist für Bremsenmotoren. Getrieben mit 63 und 71 typ Motoren sind ohne Kühlung, andere Typen zind mit Ventilator gekühlt.



Ölçü Sayfaları Dimension Pages Abmessungsseiten



-Mil ucu çekirme deliği DIN 332 sayfa 2 / Tapped center hole to DIN 332, sheet 2 / Zentrierung mit gewinde DIN 332, Blatt 2

MRF002 MRF003

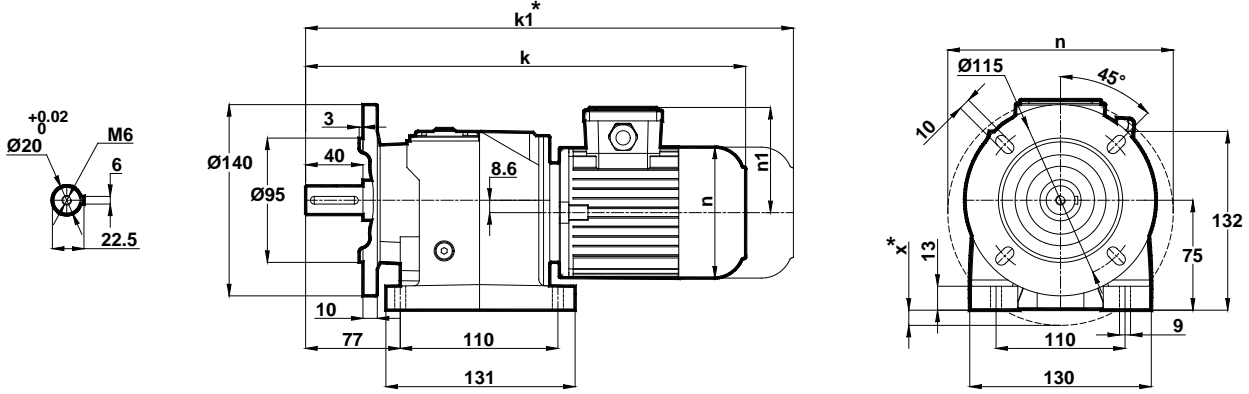

Motor Büyüklüğü / Motor Size / Motorbaugroße	63	71	80	90S	90L
k	368	387	415	443	483
k1	421	507	535	568	608
n	121	138	156	176	176
n1	97	111	118	126	126
x	-	5	14	24	24

Klemens Kutusu / Terminal Box / Klemmenkasten

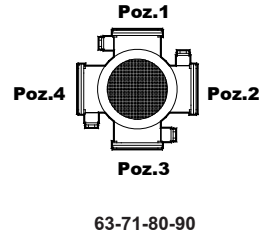

Opsiyonel Flanş Ölçüleri / Optional Flange Dimensions / Auswählbare Flanschabmessungen

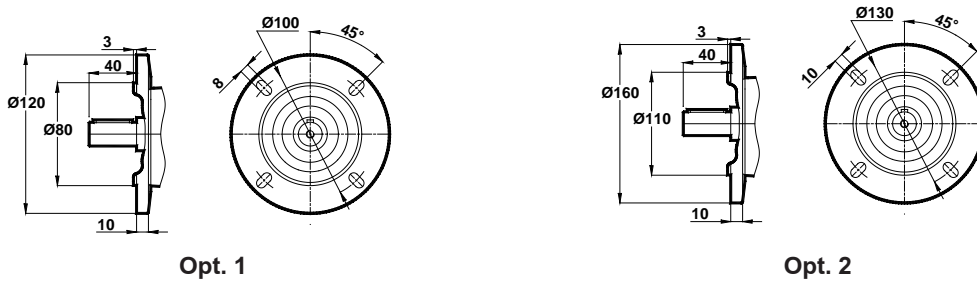

* "k1" Ölçüsü frenli redüktörlere aittir. 63, 71 tip elektrik motorlu redüktörler soğutmasız, diğerleri soğutmalıdır.
Dimension "k1" is for motors with brake. Gearboxes with 63 and 71 type electrical motors are not fan cooled, other types are fan cooled.
Maße "k1" ist für Bremsenmotoren. Getrieben mit 63 und 71 typ Motoren sind ohne Kühlung, andere Typen sind mit Ventilator gekühlt.
x: Motor, ayak bağlantı yüzeyinin altında ise / x: If Motor is lower then foot mounting plane / x: Wenn motor ist niedriger den die Anschlußplatte



Ölçü Sayfaları Dimension Pages Abmessungsseiten



-Mil ucu çektirme deliği DIN 332 sayfa 2 / Tapped center hole to DIN 332, sheet 2 / Zentrierung mit gewinde DIN 332, Blatt 2

MRF102 MRF103

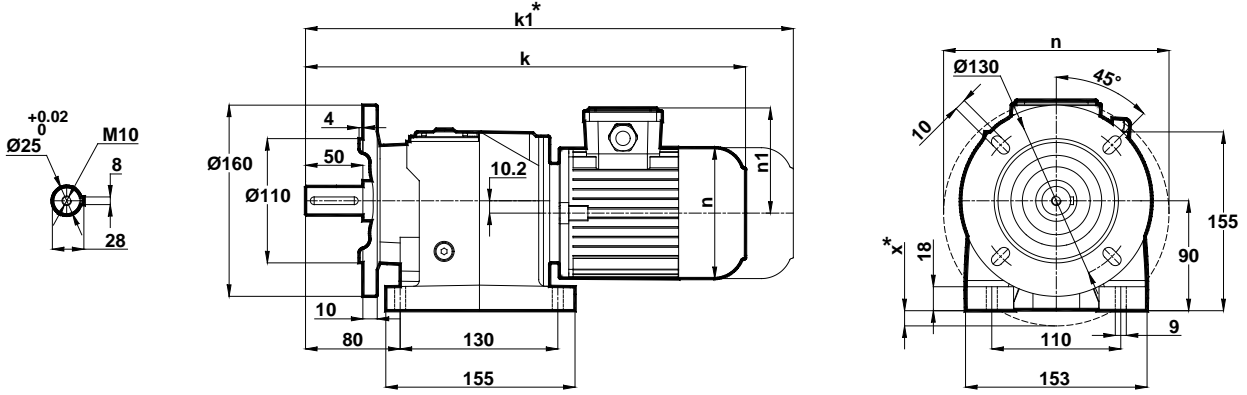

Motor Büyüklüğü / Motor Size / Motorbaugroße	63	71	80	90S	90L
k	394	413	442	471	596
k1	447	533	562	596	633
n	121	138	156	176	176
n1	97	111	118	126	126
x	-	-	-	10	10

Klemens Kutusu / Terminal Box / Klemmenkasten

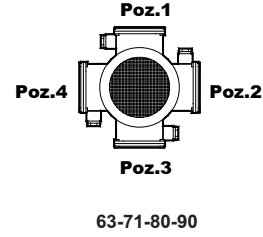

Opsiyonel Flanş Ölçüleri / Optional Flange Dimensions / Auswählbare Flanschabmessungen

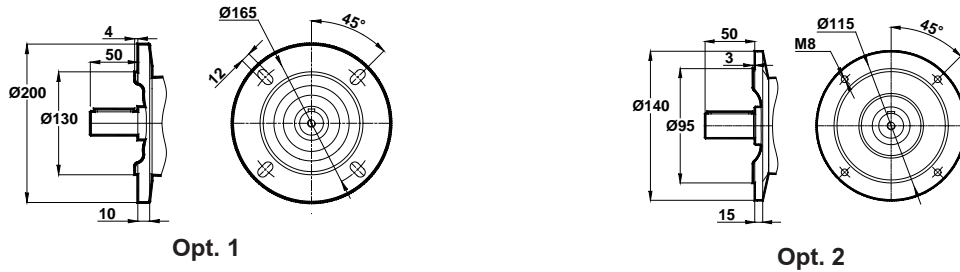

* "k1" ölçüsü frenli redüktörlere aittir. 63, 71 tip elektrik motorlu redüktörler soğutmasız, diğerleri soğutmalıdır.

Dimension "k1" is for motors with brake. Gearboxes with 63 and 71 type electrical motors are not fan cooled, other types are fan cooled.

Maße "k1" ist für Bremsenmotoren. Getrieben mit 63 und 71 typ Motoren sind ohne Kühlung, andere Typen sind mit Ventilator gekühlt.

x: Motor ayak bağlantı yüzeyinin altında ise / x: If Motor is lower than foot mounting plane / x: Wenn motor ist niedriger den die Anschlussplatte



Ölçü Sayfaları Dimension Pages Abmessungsseiten



-Mil ucu çekirme deliği DIN 332 sayfa 2 / Tapped center hole to DIN 332, sheet 2 / Zentrierung mit gewinde DIN 332, Blatt 2

MRF172 MRF173

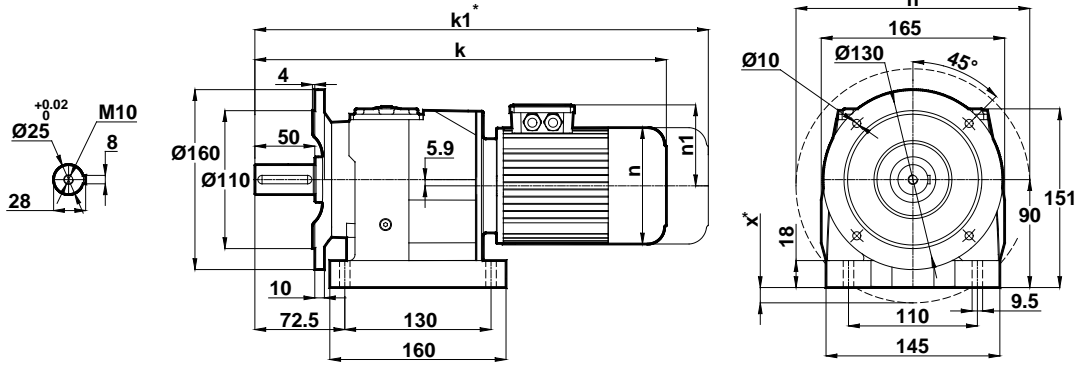

Motor Büyüklüğü / Motor Size / Motorbaugroße							
	63	71	80	90S	90L	100L	112M
k	395	414	442	470	510	536	559
k1	448	534	562	595	635	671	694
n	121	138	156	176	176	194	218
n1	97	111	118	126	126	135	146
x	-	-	-	6	6	16	28

Klemens Kutusu / Terminal Box / Klemmenkasten

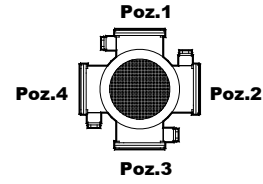

63-71-80-90-100-112

Opsiyonel Flanş Ölçüleri / Optional Flange Dimensions / Auswählbare Flanschabmessungen

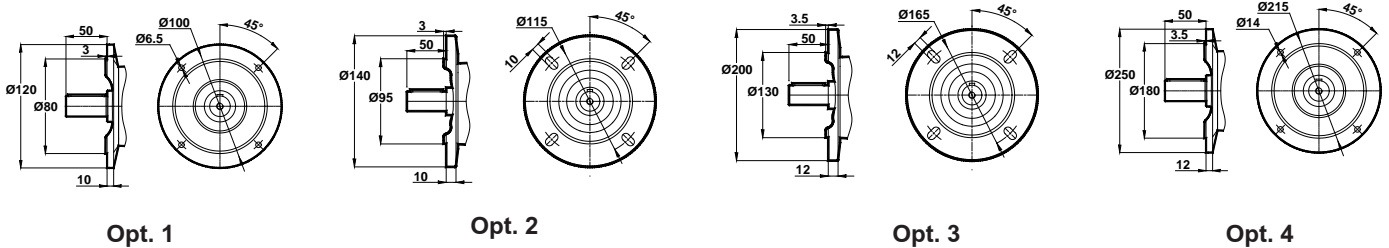

* " k1 " Ölçüsü frenli redüktörlere aittir. 63, 71 tip elektrik motorlu redüktörler soğutmasız, diğerleri soğutmalıdır.
Dimension " k1 " is for motors with brake. Gearboxes with 63 and 71 type electrical motors are not fan cooled, other types are fan cooled.
Maße " k1 " ist für Bremsenmotoren. Getrieben mit 63 und 71 typ Motoren sind ohne Kühlung, andere Typen sind mit Ventilator gekühlt.
x: Motor, ayak bağlantı yüzeyinin altında ise / x: If Motor is lower then foot mounting plane / x: Wenn motor ist niedriger den die Anschlußplatte



Ölçü Sayfaları Dimension Pages Abmessungenseiten



-Mil ucu çektirme deliği DIN 332 sayfa 2 / Tapped center hole to DIN 332, sheet 2 / Zentrierung mit gewinde DIN 332, Blatt 2

MRF202 MRF203

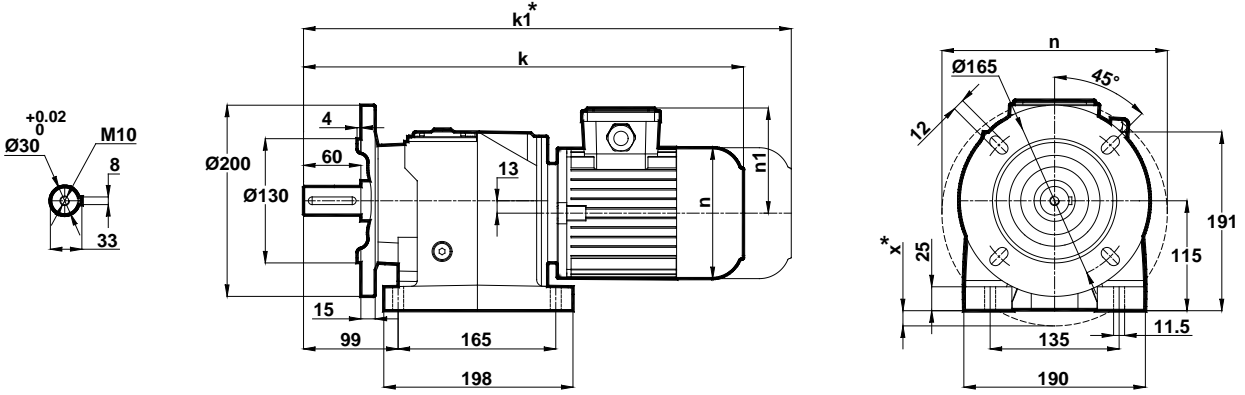

Motor Büyüklüğü / Motor Size / Motorbaugroße							
	63	71	80	90S	90L	100L	112M
k	442	461	489	517	542	583	606
k1	495	581	609	642	667	718	741
n	121	138	156	176	176	194	218
n1	97	111	118	126	126	135	146
x	-	-	-	-	-	-	10

Klemens Kutusu / Terminal Box / Klemmenkasten

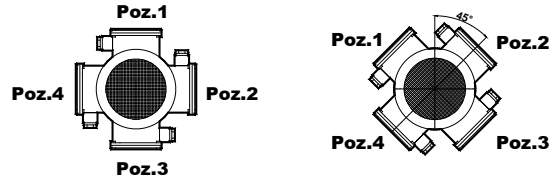

63-80-90-100-112

71

Opsiyonel Flanş Ölçüleri / Optional Flange Dimensions / Auswählbare Flanschabmessungen

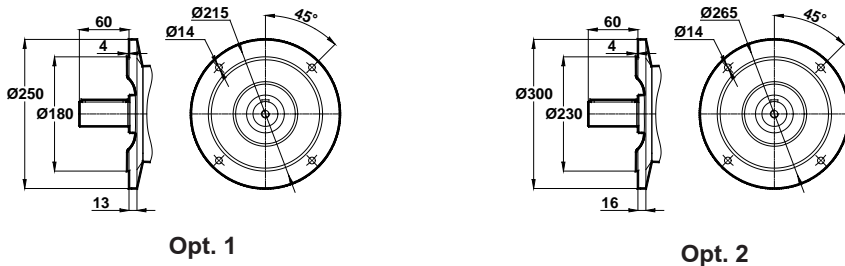

Opt. 1

Opt. 2

* "k1" ölçüsü frenli redüktörlere aittir. 63, 71 tip elektrik motorlu redüktörler soğutmasız, diğerleri soğutmalıdır.

Dimension "k1" is for motors with brake. Gearboxes with 63 and 71 type electrical motors are not fan cooled, other types are fan cooled.

Maße "k1" ist für Bremsenmotoren. Getrieben mit 63 und 71 typ Motoren sind ohne Kühlung, andere Typen sind mit Ventilator gekühlt.

x: Motor ayak bağlantı yüzeyinin altında ise / x: If Motor is lower than foot mounting plane / x: Wenn motor ist niedriger den die Anschlußplatte



Ölçü Sayfaları Dimension Pages Abmessungsseiten



-Mil ucu çekirme deliği DIN 332 sayfa 2 / Tapped center hole to DIN 332, sheet 2 / Zentrierung mit gewinde DIN 332, Blatt 2

MRF272
MRF273

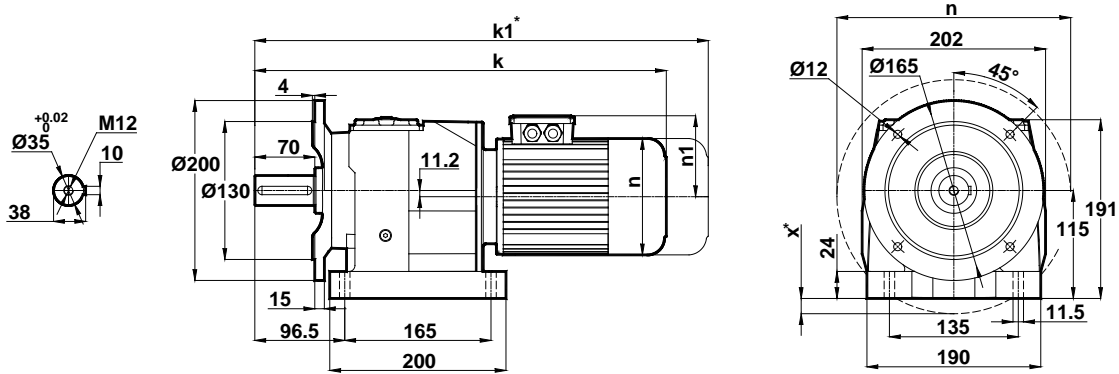

Motor Büyüklüğü / Motor Size / Motorbaugroße							
	63	71	80	90S	90L	100L	112M
k	443	462	490	518	543	584	607
k1	496	582	610	643	668	719	742
n	121	138	156	176	176	194	218
n1	97	111	118	126	126	135	146
x	-	-	-	-	-	-	9

Klemens Kutusu / Terminal Box / Klemmenkasten

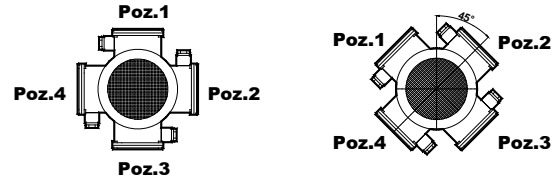

63-80-90-100-112

71

Opsiyonel Flanş Ölçüleri / Optional Flange Dimensions / Auswählbare Flanschabmessungen

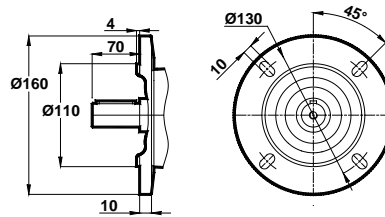

Opt. 1

* "k1" Ölçüsü frenli redüktörlere aittir. 63, 71 tip elektrik motorlu redüktörler soğutmasız, diğerleri soğutmalıdır.

Dimension "k1" is for motors with brake. Gearboxes with 63 and 71 type electrical motors are not fan cooled, other types are fan cooled.

Maße "k1" ist für Bremsenmotoren. Getrieben mit 63 und 71 typ Motoren sind ohne Kühlung, andere Typen sind mit Ventilator gekühlt.

x: Motor, ayak bağlantı yüzeyinin altında ise / x: If Motor is lower than foot mounting plane / x: Wenn motor ist niedriger den die Anschlußplatte



Ölçü Sayfaları Dimension Pages Abmessungsseiten



-Mil ucu çekirtme deliği DIN 332 sayfa 2 / Tapped center hole to DIN 332, sheet 2 / Zentrierung mit gewinde DIN 332, Blatt 2

MRF275 MRF276

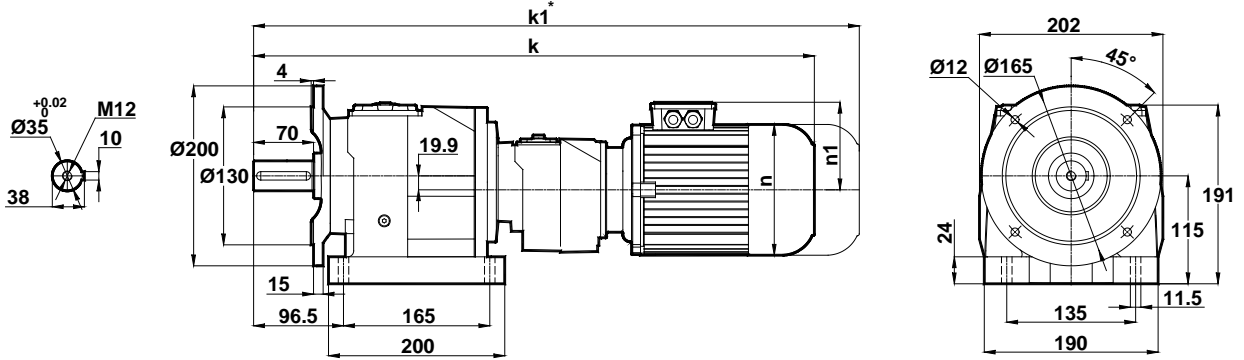

Motor Büyüklüğü / Motor Size / Motorbaugroße	63	71
k	593	614
k1	646	734
n	121	138
n1	97	111

Klemens Kutusu / Terminal Box / Klemmenkasten

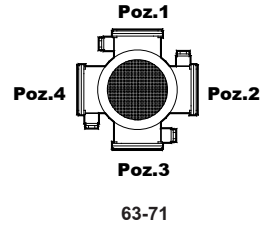

Opsiyonel Flanş Ölçüleri / Optional Flange Dimensions / Auswählbare Flanschabmessungen

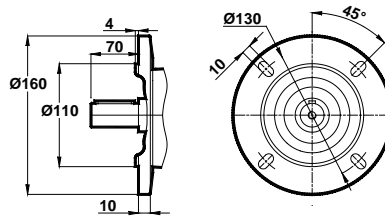

Opt. 1

* " k1 " Ölçüsü frenli redüktörlere aittir. 63, 71 tip elektrik motorlu redüktörler soğutmasız, diğerleri soğutmalıdır.

Dimension " k1 " is for motors with brake. Gearboxes with 63 and 71 type electrical motors are not fan cooled, other types are fan cooled.

Maße " k1 " ist für Bremsenmotoren. Getrieben mit 63 und 71 typ Motoren sind ohne Kühlung, andere Typen sind mit Ventilator gekühlt.



Ölçü Sayfaları

Dimension Pages

Abmessungsseiten



-Mil ucu çekirtilme deliği DIN 332 sayfa 2 / Tapped center hole to DIN 332, sheet 2 / Zentrierung mit gewinde DIN 332, Blatt 2

MRF282

MRF283

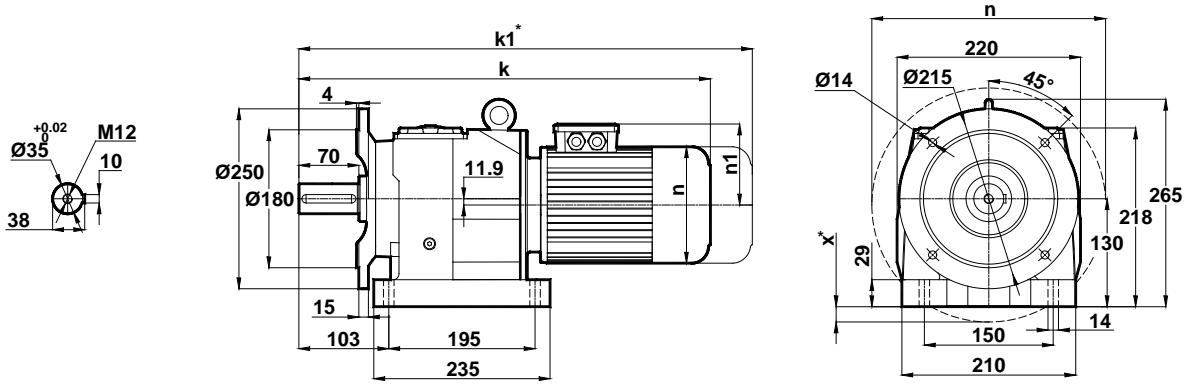

Motor Büyüklüğü / Motor Size / Motorbaugroße								
	71	80	90S	90L	100L	112M	132S	132M
k	479	507	537	562	602	625	679	717
k1	599	627	662	687	737	760	824	862
n	138	156	176	176	194	218	257	257
n1	111	118	126	126	135	146	168	168
x	-	-	-	-	-	-	-	14

Klemens Kutusu / Terminal Box / Klemmenkasten

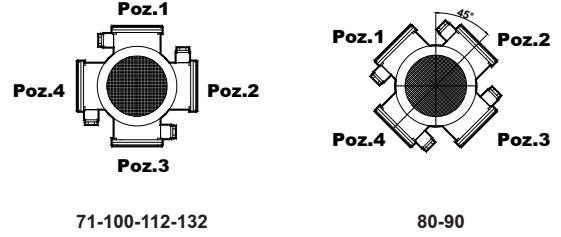

Opsiyonel Flanş Ölçüleri / Optional Flange Dimensions / Auswählbare Flanschabmessungen

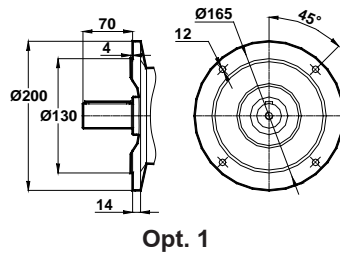

* “k1” ölçüsü frenli redüktörlere aittir. 63, 71 tip elektrik motorlu redüktörler soğutmasız, diğerleri soğutmalıdır.
 Dimension “k1” is for motors with brake. Gearboxes with 63 and 71 type electrical motors are not fan cooled, other types are fan cooled.
 Maße “k1” ist für Bremsenmotoren. Getrieben mit 63 und 71 typ Motoren sind ohne Kühlung, andere Typen sind mit Ventilator gekühlt.
 x: Motor, ayak bağlantı yüzeyinin altında ise / x: If Motor is lower then foot mounting plane / x: Wenn motor ist niedriger den die Anschlußplatte



Ölçü Sayfaları Dimension Pages Abmessungenseiten



-Mil ucu çektirme deliği DIN 332 sayfa 2 / Tapped center hole to DIN 332, sheet 2 / Zentrierung mit gewinde DIN 332, Blatt 2

MRF284

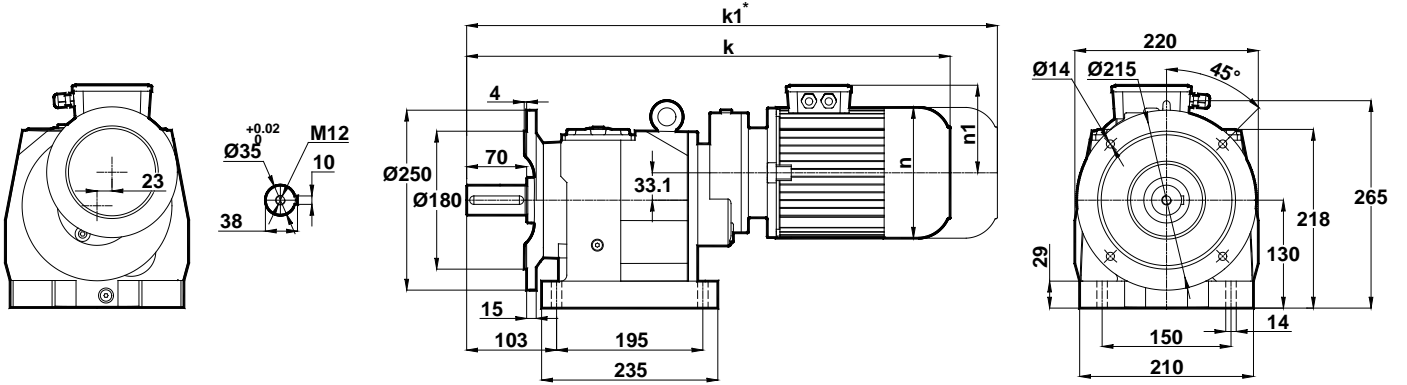

Motor Büyüklüğü / Motor Size / Motorbaugroße	63	71
k	540	558
k1	593	678
n	121	138
n1	97	111

Klemens Kutusu / Terminal Box / Klemmenkasten

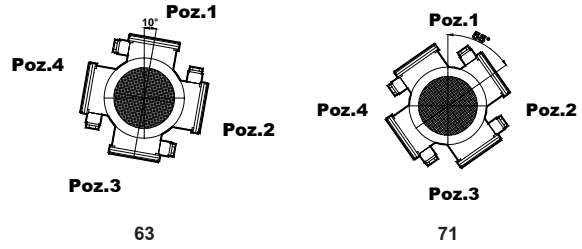

Opsiyonel Flanş Ölçüleri / Optional Flange Dimensions / Auswählbare Flanschabmessungen

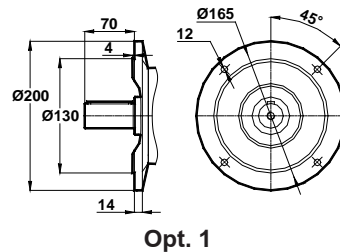

* " k1 " Ölçüsü frenli redüktörlere aittir. 63, 71 tip elektrik motorlu redüktörler soğutmasız, diğerleri soğutmalıdır.

Dimension " k1 " is for motors with brake. Gearboxes with 63 and 71 type electrical motors are not fan cooled, other types are fan cooled.

Maße " k1 " ist für Bremsenmotoren. Getrieben mit 63 und 71 typ Motoren sind ohne Kühlung, andere Typen zind mit Ventilator gekühlt.



Ölçü Sayfaları Dimension Pages Abmessungsseiten



-Mil ucu çektirme deliği DIN 332 sayfa 2 / Tapped center hole to DIN 332, sheet 2 / Zentrierung mit gewinde DIN 332, Blatt 2

MRF285
MRF286

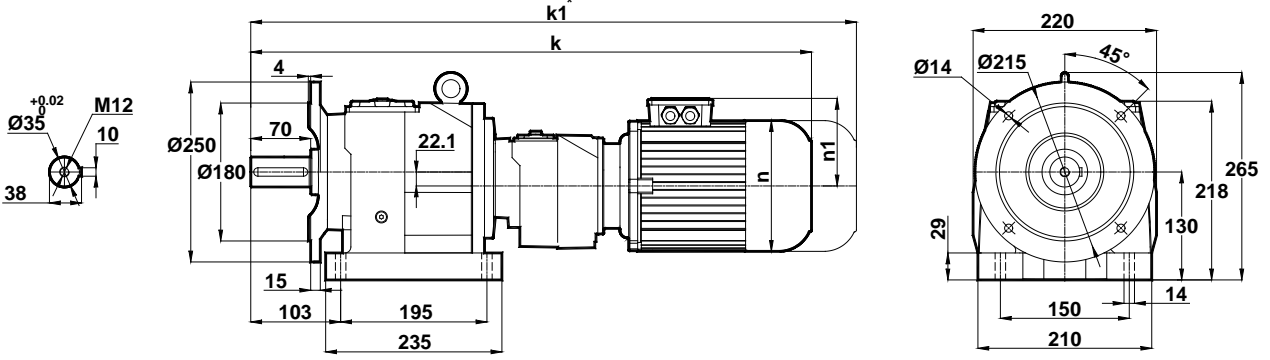

Motor Büyüklüğü / Motor Size / Motorbaugroße	
	63
k	641
k1	694
n	121
n1	97

Klemens Kutusu / Terminal Box / Klemmenkasten

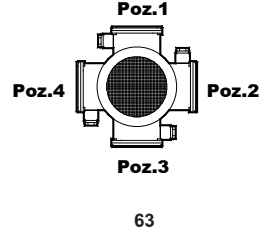

Opsiyonel Flanş Ölçüleri / Optional Flange Dimensions / Auswählbare Flanschabmessungen

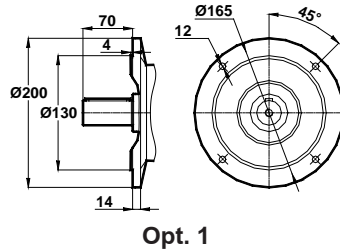

* " k1 " Ölçüsü frenli redüktörlere aittir. 63, 71 tip elektrik motorlu redüktörler soğutmasız, diğerleri soğutmalıdır.
Dimension " k1 " is for motors with brake. Gearboxes with 63 and 71 type electrical motors are not fan cooled, other types are fan cooled.
Maße " k1 " ist für Bremsenmotoren. Getrieben mit 63 und 71 typ Motoren sind ohne Kühlung, andere Typen sind mit Ventilator gekühlt.



Ölçü Sayfaları Dimension Pages Abmessungsseiten



-Mil ucu çektirme deliği DIN 332 sayfa 2 / Tapped center hole to DIN 332, sheet 2 / Zentrierung mit gewinde DIN 332, Blatt 2

MRF372
MRF373

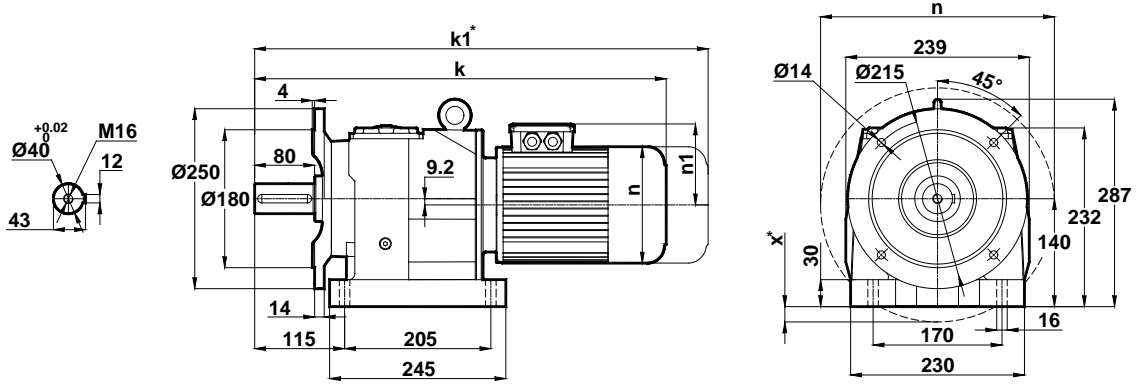

Motor Büyüklüğü / Motor Size / Motorbaugroße								
	71	80	90S	90L	100L	112M	132S	132M
k	500	528	558	583	623	646	700	738
k1	620	648	683	708	758	781	845	883
n	138	156	176	176	194	218	257	257
n1	111	118	126	126	135	146	168	168
x	-	-	-	-	-	-	2	30

Klemens Kutusu / Terminal Box / Klemmenkasten

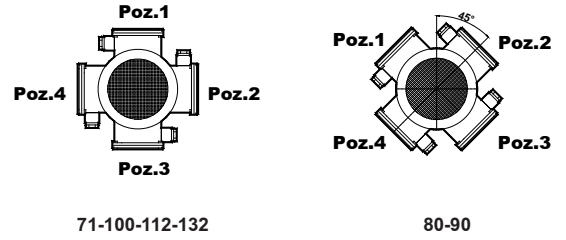

Opsiyonel Flanş Ölçüleri / Optional Flange Dimensions / Auswählbare Flanschabmessungen

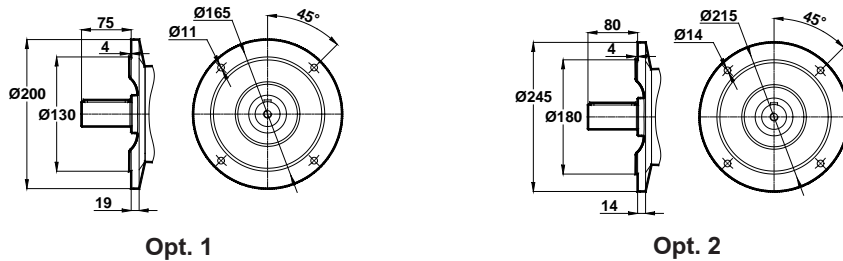

* " k1 " Ölçüsü frenli redüktörlere aittir. 63, 71 tip elektrik motorlu redüktörler soğutmasız, diğerleri soğutmalıdır.
Dimension " k1 " is for motors with brake. Gearboxes with 63 and 71 type electrical motors are not fan cooled, other types are fan cooled.
Maße " k1 " ist für Bremsenmotoren. Getrieben mit 63 und 71 typ Motoren sind ohne Kühlung, andere Typen sind mit Ventilator gekühlt.
x: Motor, ayak bağlantı yüzeyinin altında ise / x: If Motor is lower then foot mounting plane / x: Wenn motor ist niedriger den die Anschlußplatte



Ölçü Sayfaları Dimension Pages Abmessungsseiten



-Mil ucu çekirme deliği DIN 332 sayfa 2 / Tapped center hole to DIN 332, sheet 2 / Zentrierung mit gewinde DIN 332, Blatt 2

MRF374

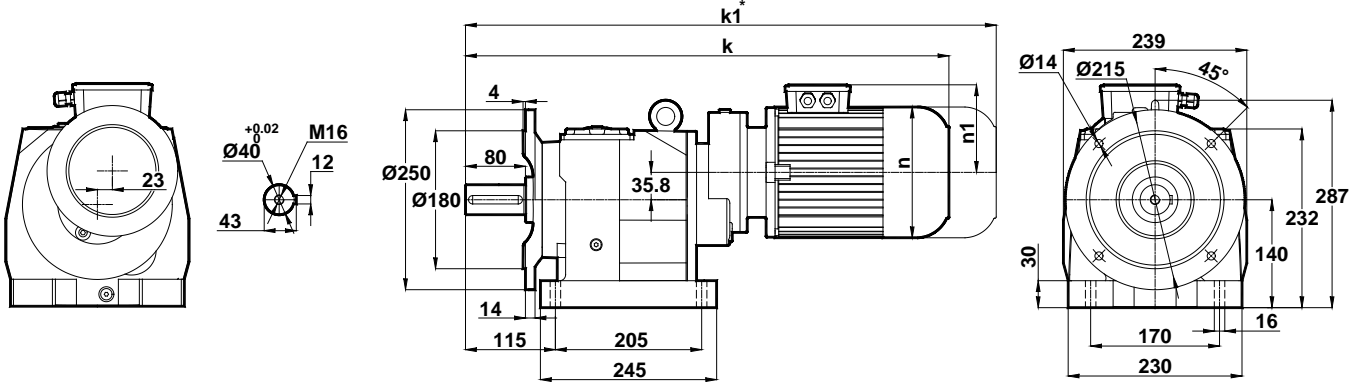

Motor Büyüklüğü / Motor Size / Motorbaugroße			
	63	71	80
k	561	579	608
k1	614	699	728
n	121	138	156
n1	97	111	118

Klemens Kutusu / Terminal Box / Klemmenkasten

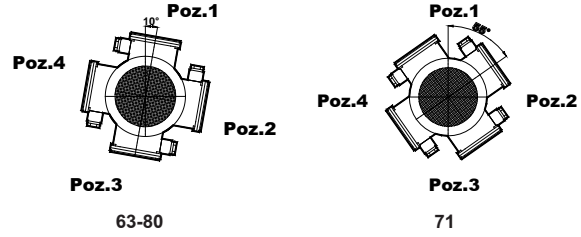

Opsiyonel Flanş Ölçüleri / Optional Flange Dimensions / Auswählbare Flanschabmessungen

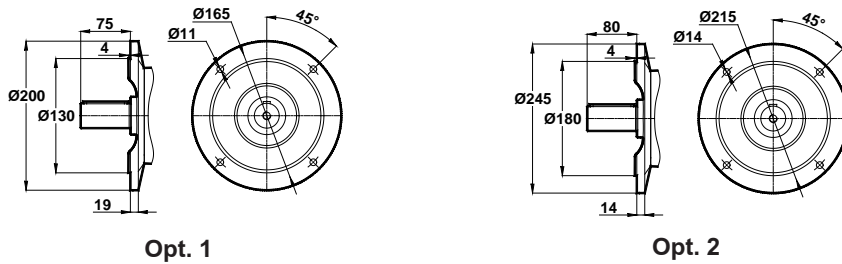

* " k1 " Ölçüsü frenli redüktörlere aittir. 63, 71 tip elektrik motorlu redüktörler soğutmasız, diğerleri soğutmalıdır.
Dimension " k1 " is for motors with brake. Gearboxes with 63 and 71 type electrical motors are not fan cooled, other types are fan cooled.
Maße " k1 " ist für Bremsenmotoren. Getrieben mit 63 und 71 typ Motoren sind ohne Kühlung, andere Typen zind mit Ventilator gekühlt.



Ölçü Sayfaları Dimension Pages Abmessungsseiten



-Mil ucu çektirme deliği DIN 332 sayfa 2 / Tapped center hole to DIN 332, sheet 2 / Zentrierung mit gewinde DIN 332, Blatt 2

MRF375
MRF376

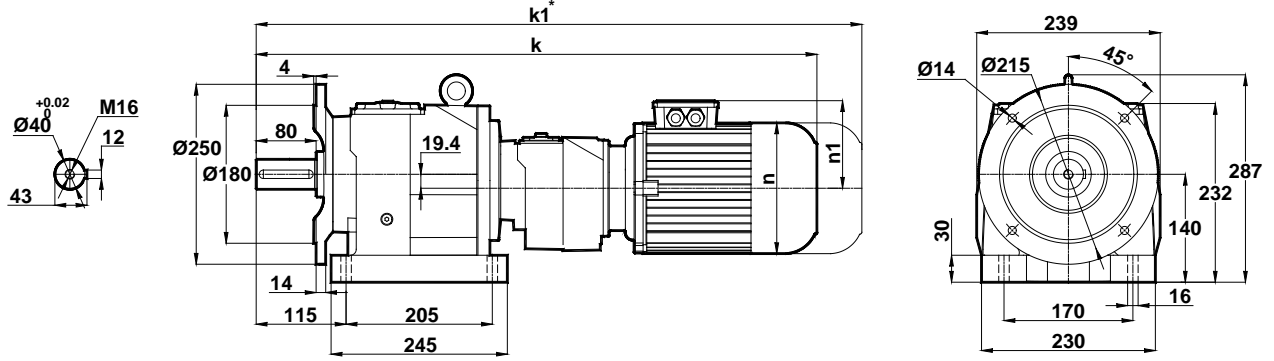

Motor Büyüklüğü / Motor Size / Motorbaugroße	
	63
k	662
k1	715
n	121
n1	97

Klemens Kutusu / Terminal Box / Klemmenkasten

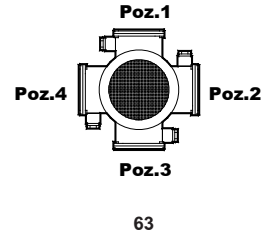

Opsiyonel Flanş Ölçüleri / Optional Flange Dimensions / Auswählbare Flanschabmessungen

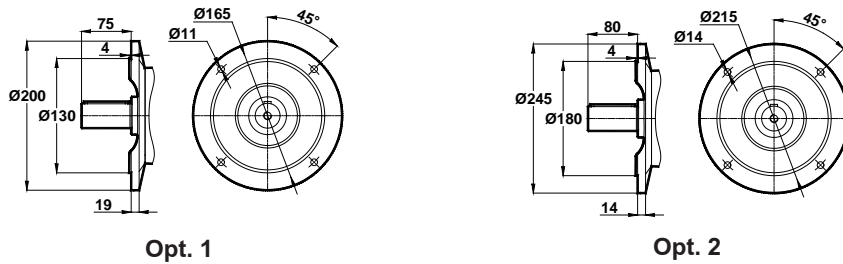

* " k1 " Ölçüsü frenli redüktörlere aittir. 63, 71 tip elektrik motorlu redüktörler soğutmasız, diğerleri soğutmalıdır.
Dimension " k1 " is for motors with brake. Gearboxes with 63 and 71 type electrical motors are not fan cooled, other types are fan cooled.
Maße " k1 " ist für Bremsenmotoren. Getrieben mit 63 und 71 typ Motoren sind ohne Kühlung, andere Typen zind mit Ventilator gekühlt.



Ölçü Sayfaları Dimension Pages Abmessungenseiten



-Mil ucu çektirme deliği DIN 332 sayfa 2 / Tapped center hole to DIN 332, sheet 2 / Zentrierung mit gewinde DIN 332, Blatt 2

MRF472
MRF473

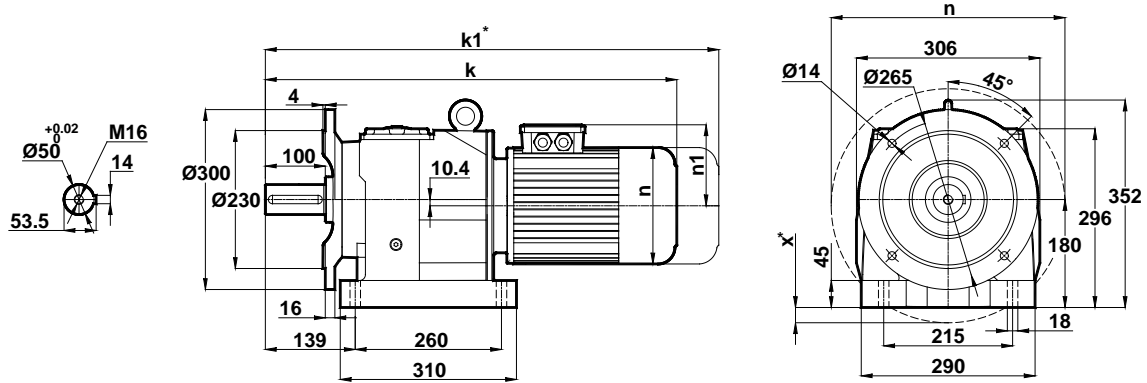

Motor Büyüklüğü / Motor Size / Motorbaugroße											
	80	90S	90L	100L	112M	132S	132M	160M	160L	180M	180L
k	596	624	649	688	713	762	800	875	919	936	974
k1	716	749	774	823	848	907	945	1045	1089	1106	1144
n	156	176	176	194	218	257	257	310	310	348	348
n1	118	126	126	135	146	168	168	225	225	241	241
x	-	-	-	-	-	-	-	-	-	11	11

Klemens Kutusu / Terminal Box / Klemmenkasten

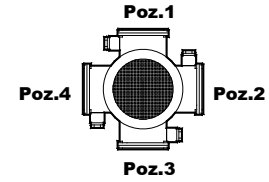

80-90-100-112-132-160-180

Opsiyonel Flanş Ölçüleri / Optional Flange Dimensions / Auswählbare Flanschabmessungen

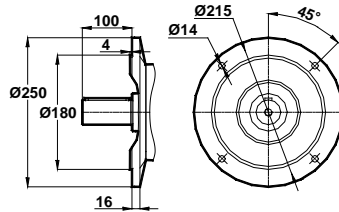

Opt. 1

* " k1 " Ölçüsü frenli redüktörlere aittir. 63, 71 tip elektrik motorlu redüktörler soğutmasız, diğerleri soğutmalıdır.

Dimension " k1 " is for motors with brake. Gearboxes with 63 and 71 type electrical motors are not fan cooled, other types are fan cooled.

Maße " k1 " ist für Bremsenmotoren. Getrieben mit 63 und 71 typ Motoren sind ohne Kühlung, andere Typen sind mit Ventilator gekühlt.

x: Motor, ayak bağlantı yüzeyinin altında ise / x: If Motor is lower than foot mounting plane / x: Wenn motor ist niedriger den die Anschlußplatte



Ölçü Sayfaları Dimension Pages Abmessungsseiten



-Mil ucu çektirme deliği DIN 332 sayfa 2 / Tapped center hole to DIN 332, sheet 2 / Zentrierung mit gewinde DIN 332, Blatt 2

MRF474

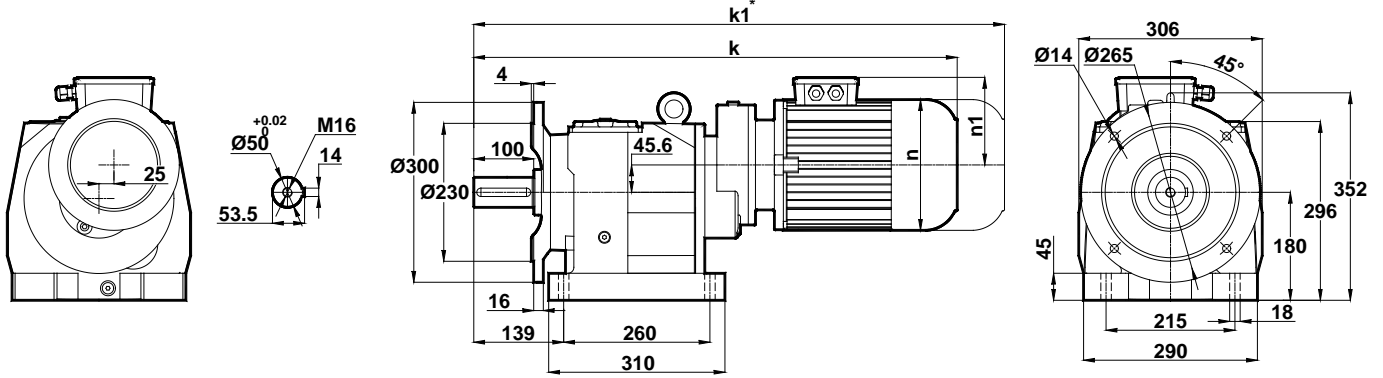

Motor Büyüklüğü / Motor Size / Motorbaugroße		
	71	80
k	661	689
k1	781	809
n	138	156
n1	111	118

Klemens Kutusu / Terminal Box / Klemmenkasten

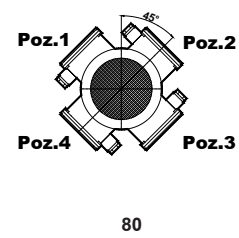
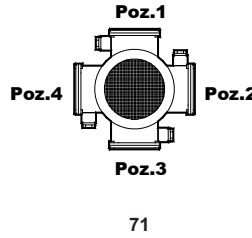

Opsiyonel Flanş Ölçüleri / Optional Flange Dimensions / Auswählbare Flanschabmessungen

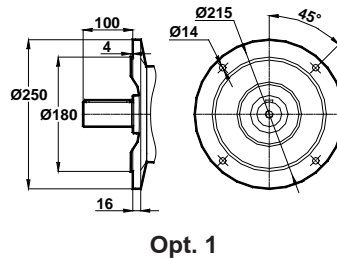

Opt. 1

* " k1 " Ölçüsü frenli redüktörlere aittir. 63, 71 tip elektrik motorlu redüktörler soğutmasız, diğerleri soğutmalıdır.

Dimension " k1 " is for motors with brake. Gearboxes with 63 and 71 type electrical motors are not fan cooled, other types are fan cooled.

Maße " k1 " ist für Bremsenmotoren. Getrieben mit 63 und 71 typ Motoren sind ohne Kühlung, andere Typen zind mit Ventilator gekühlt.



Ölçü Sayfaları Dimension Pages Abmessungsseiten



-Mil ucu çekirme deliği DIN 332 sayfa 2 / Tapped center hole to DIN 332, sheet 2 / Zentrierung mit gewinde DIN 332, Blatt 2

MRF475 MRF476

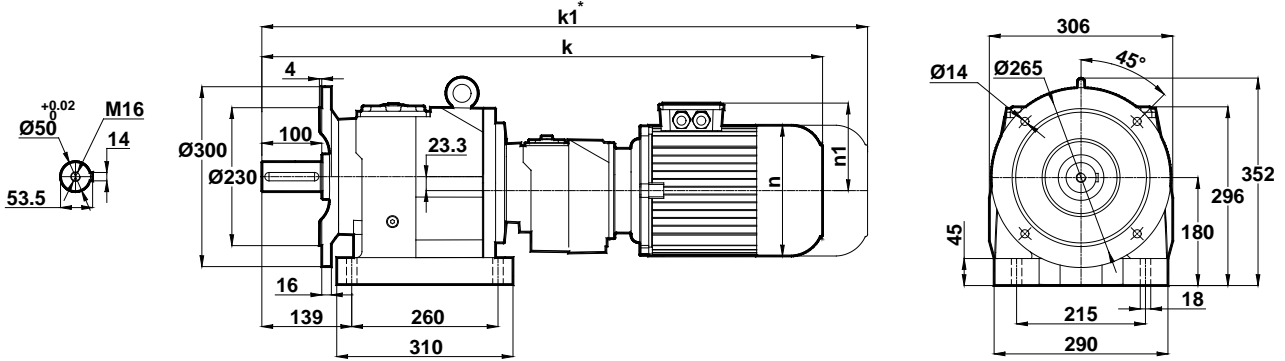

Motor Büyüklüğü / Motor Size / Motorbaugroße		
	63	71
k	772	791
k1	825	911
n	121	138
n1	97	111

Klemens Kutusu / Terminal Box / Klemmenkasten

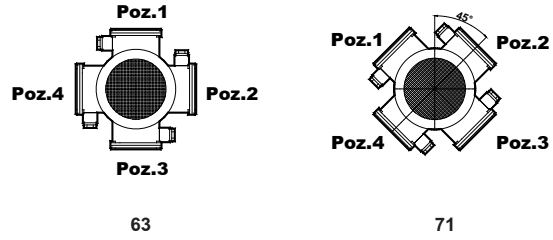

Opsiyonel Flanş Ölçüleri / Optional Flange Dimensions / Auswählbare Flanschabmessungen

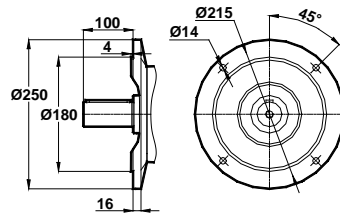

Opt. 1

* " k1 " Ölçüsü frenli redüktörlere aittir. 63, 71 tip elektrik motorlu redüktörler soğutmasız, diğerleri soğutmalıdır.
Dimension " k1 " is for motors with brake. Gearboxes with 63 and 71 type electrical motors are not fan cooled, other types are fan cooled.
Maße " k1 " ist für Bremsenmotoren. Getrieben mit 63 und 71 typ Motoren sind ohne Kühlung, andere Typen sind mit Ventilator gekühlt.



Ölçü Sayfaları Dimension Pages Abmessungsseiten



-Mil ucu çekirme deliği DIN 332 sayfa 2 / Tapped center hole to DIN 332, sheet 2 / Zentrierung mit gewinde DIN 332, Blatt 2

MNF002-A..
MNF003-A..

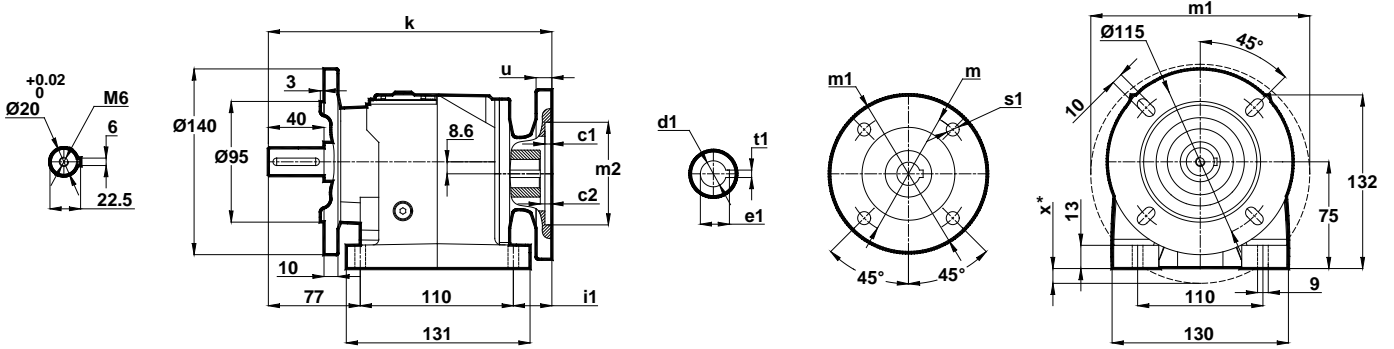

IEC	c1	c2	s1	m	m1	m2	i1	u	k	d1	t1	e1	x
63/B5	3.5	5	10	115	140	95	28	10	214	11	4	12.8	4
71/B5	4	4.5	11	130	160	110	29.5	12	216	14	5	16.3	14
80/B5	4	5	12	165	200	130	44.5	12	231	19	6	21.8	34
90/B5	4	5	12	165	200	130	44.5	12	231	24	8	27.3	34

Opsiyonel Flanş Ölçüleri / Optional Flange Dimensions / Auswählbare Flanschabmessungen

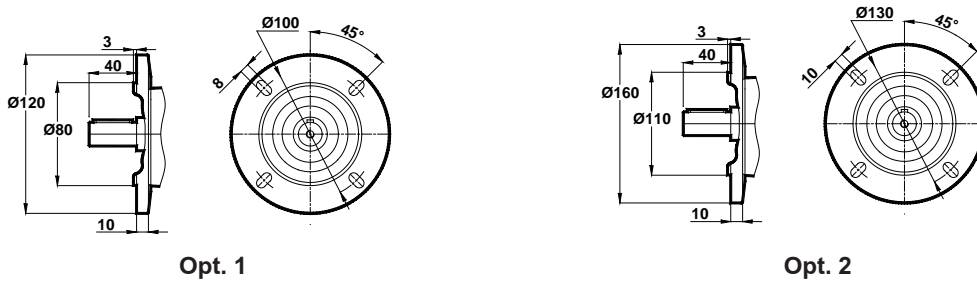

x: Motor, ayak bağlantı yüzeyinin altında ise / x: If Motor is lower then foot mounting plane / x: Wenn motor ist niedriger den die Anschlussplatte



Ölçü Sayfaları Dimension Pages Abmessungsseiten



-Mil ucu çektirme deliği DIN 332 sayfa 2 / Tapped center hole to DIN 332, sheet 2 / Zentrierung mit gewinde DIN 332, Blatt 2

MNF002-B..
MNF003-B..

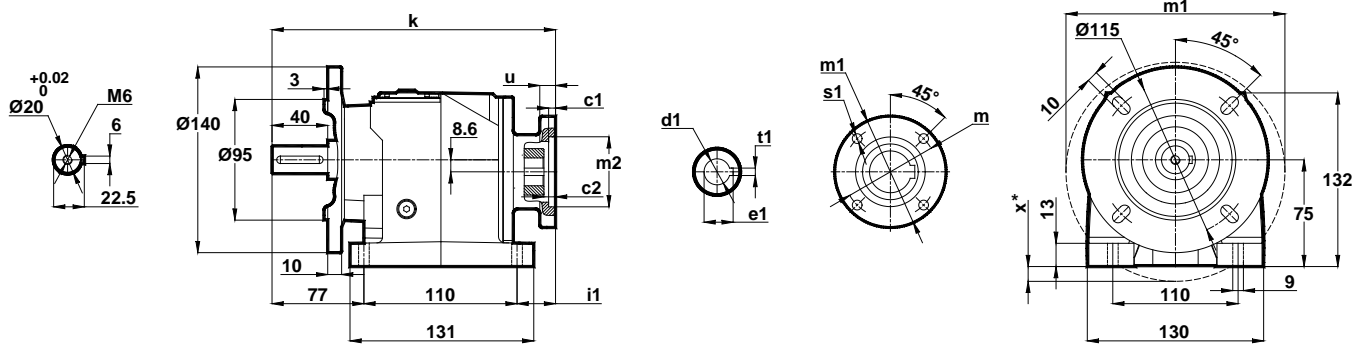

IEC	c1	c2	s1	m	m1	m2	i1	u	k	d1	t1	e1	x
63/B14	2.5	5	5.5	75	90	60	28	10	214	11	4	12.8	-
71/B14	3	4.5	7	85	105	70	29.5	10	216	14	5	16.3	-
80/B14	4	5	7	100	120	80	44.5	12	231	19	6	21.8	-
90/B14	4	5	9	115	140	95	44.5	12	231	24	8	27.3	4

Opsiyonel Flanş Ölçüleri / Optional Flange Dimensions / Auswählbare Flanschabmessungen

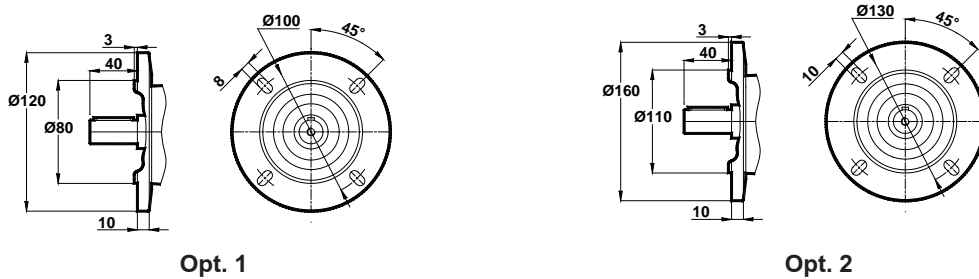

x: Motor Ayak bağlantı yüzeyinin altında ise / x: If Motor is lower then foot mounting plane / x: Wenn motor ist niedriger den die Anschlußplatte



Ölçü Sayfaları Dimension Pages Abmessungsseiten



-Mil ucu çekirme deliği DIN 332 sayfa 2 / Tapped center hole to DIN 332, sheet 2 / Zentrierung mit gewinde DIN 332, Blatt 2

MNF102-A..
MNF103-A..

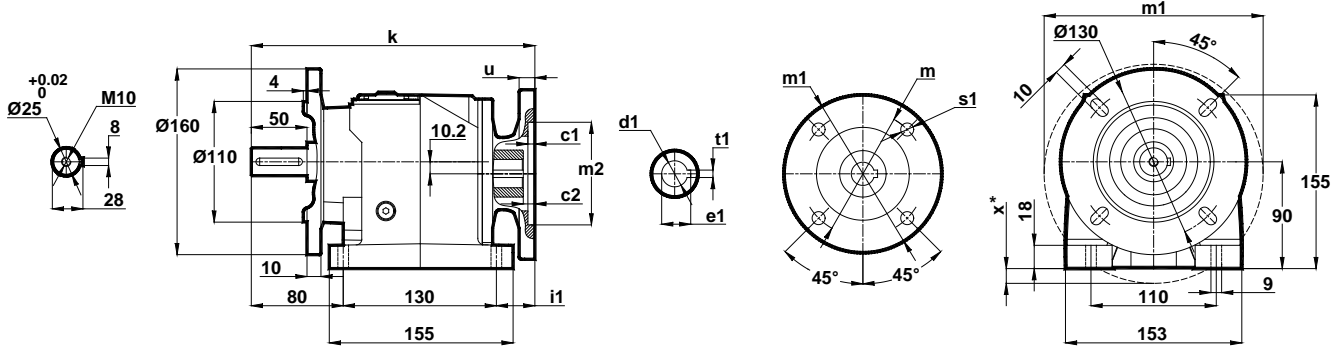

IEC	c1	c2	s1	m	m1	m2	i1	u	k	d1	t1	e1	x
63/B5	4	7	10	115	140	95	28.5	12	240	11	4	12.8	-
71/B5	4	4.5	12	130	160	110	28.5	12	240	14	5	16.3	0.5
80/B5	4	5	12	165	200	130	43.5	12	255	19	6	21.8	20
90/B5	4	5	12	165	200	130	43.5	12	255	24	8	27.3	20

Opsiyonel Flanş Ölçüleri / Optional Flange Dimensions / Auswählbare Flanschabmessungen

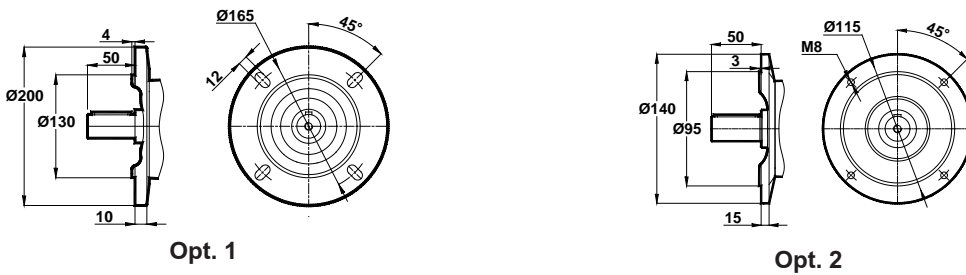

x: Motor, ayak bağlantı yüzeyinin altında ise / x: If Motor is lower then foot mounting plane / x: Wenn motor ist niedriger den die Anschlußplatte



Ölçü Sayfaları Dimension Pages Abmessungenseiten



-Mil ucu çektirme deliği DIN 332 sayfa 2 / Tapped center hole to DIN 332, sheet 2 / Zentrierung mit gewinde DIN 332, Blatt 2

MNF102-B..
MNF103-B..

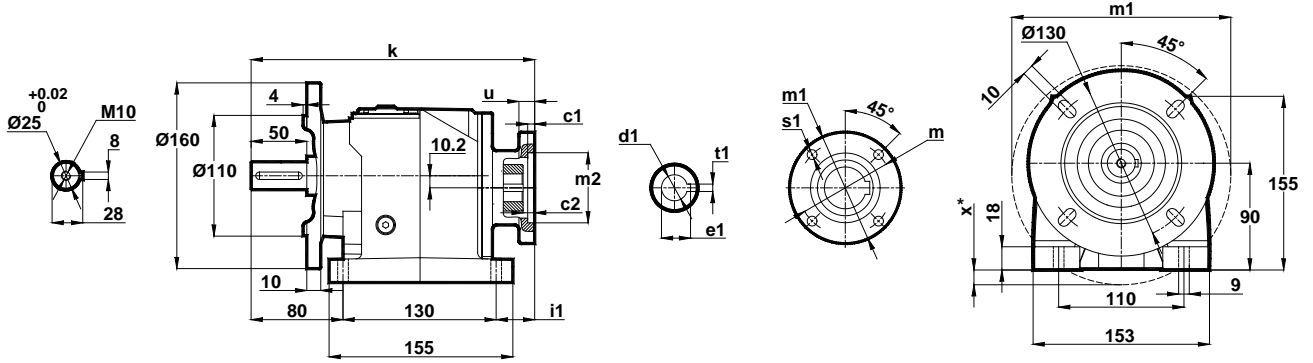

IEC	c1	c2	s1	m	m1	m2	i1	u	k	d1	t1	e1	x
63/B14	2.5	5	5.5	75	90	60	28.5	10	240	11	4	12.8	-
71/B14	3	4.5	7	85	105	70	28.5	10	240	14	5	16.3	-
80/B14	4	4.7	7	100	120	80	43.5	12	255	19	6	21.8	-
90/B14	4	4.7	9	115	140	95	43.5	12	255	24	8	27.3	-

Opsiyonel Flanş Ölçüleri / Optional Flange Dimensions / Auswählbare Flanschabmessungen

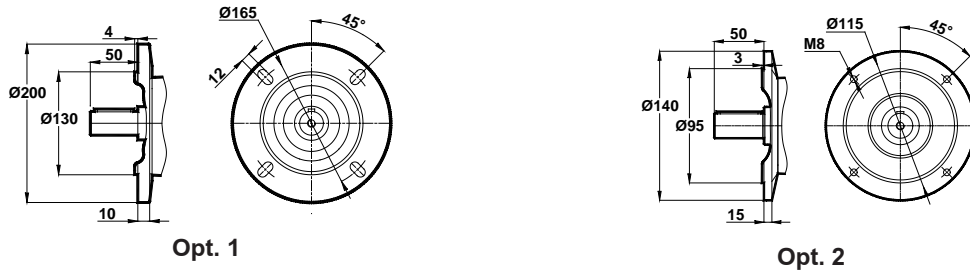

x: Motor Ayak bağlantı yüzeyinin altında ise / x: If Motor is lower than foot mounting plane / x: Wenn motor ist niedriger den die Anschlußplatte



Ölçü Sayfaları Dimension Pages Abmessungsseiten



-Mil ucu çekirme deliği DIN 332 sayfa 2 / Tapped center hole to DIN 332, sheet 2 / Zentrierung mit gewinde DIN 332, Blatt 2

MNF172-A..
MNF173-A..

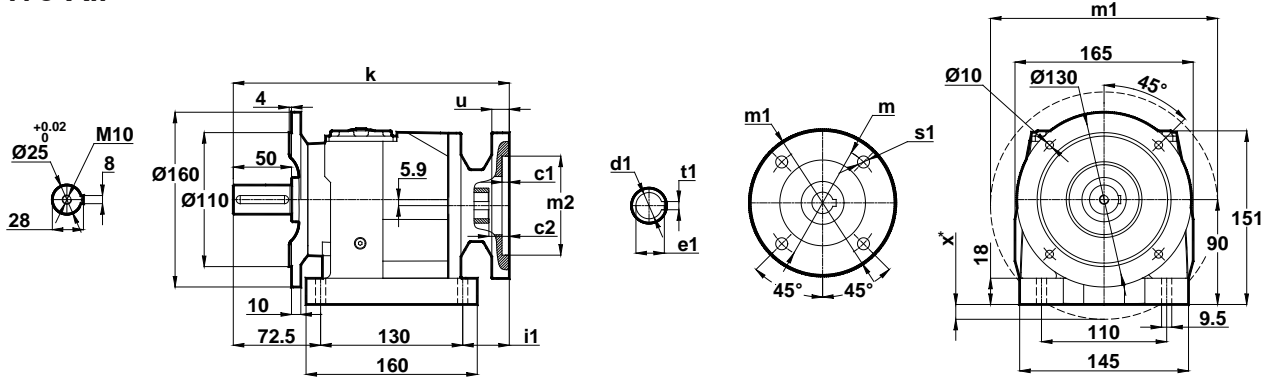

IEC	c1	c2	s1	m	m1	m2	i1	u	k	d1	t1	e1	x
63/B5	3.5	5	10	115	140	95	38.5	10	241	11	4	12.8	-
71/B5	4	4.5	11	130	160	110	40	12	243	14	5	16.3	-
80/B5	4	5	12	165	200	130	55	12	258	19	6	21.8	16
90/B5	4	5	12	165	200	130	55	12	258	24	8	27.3	16
100/B5	4	5	15	215	250	180	66	12	269	28	8	31.3	41
112/B5	4	5	15	215	250	180	66	12	269	28	8	31.3	41

Opsiyonel Flanş Ölçüleri / Optional Flange Dimensions / Auswählbare Flanschabmessungen

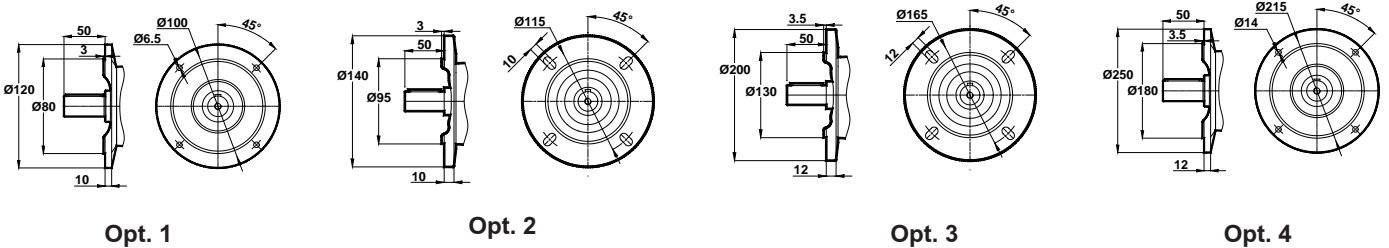

x: Motor, ayak bağlantı yüzeyinin altında ise / x: If Motor is lower then foot mounting plane / x: Wenn motor ist niedriger den die Anschlußplatte



Ölçü Sayfaları Dimension Pages Abmessungsseiten



-Mil ucu çektirme deliği DIN 332 sayfa 2 / Tapped center hole to DIN 332, sheet 2 / Zentrierung mit gewinde DIN 332, Blatt 2

MNF172-B..
MNF173-B..

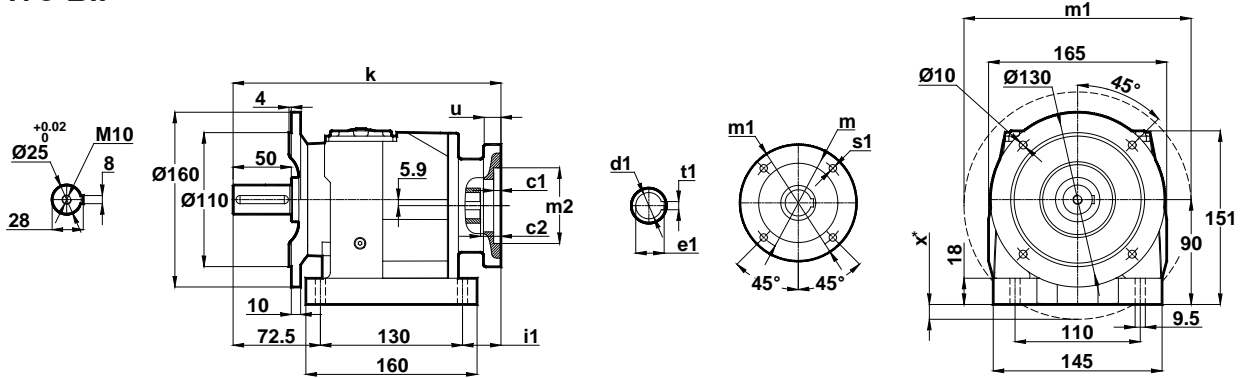

IEC	c1	c2	s1	m	m1	m2	i1	u	k	d1	t1	e1	x
71/B14	3	4.5	7	85	105	70	40	10	243	14	5	16.3	-
80/B14	4	5	7	100	120	80	55	120	258	19	6	21.8	-
90/B14	4	5	9	115	140	95	55	12	258	24	8	27.3	-
100/B14	4	5.5	9	130	160	110	66	12	269	28	8	31.3	-
112/B14	4	5.5	9	130	160	110	66	12	269	28	8	31.3	-

Opsiyonel Flanş Ölçüleri / Optional Flange Dimensions / Auswählbare Flanschabmessungen

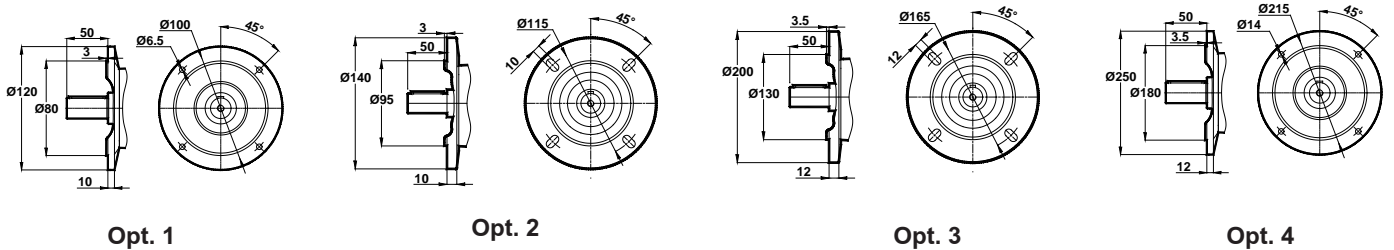

x: Motor ayak bağlantı yüzeyinin altında ise / x: If Motor is lower then foot mounting plane / x: Wenn motor ist niedriger den die Anschlußplatte



Ölçü Sayfaları Dimension Pages Abmessungsseiten



-Mil ucu çekirme deliği DIN 332 sayfa 2 / Tapped center hole to DIN 332, sheet 2 / Zentrierung mit gewinde DIN 332, Blatt 2

MNF202-A..
MNF203-A..

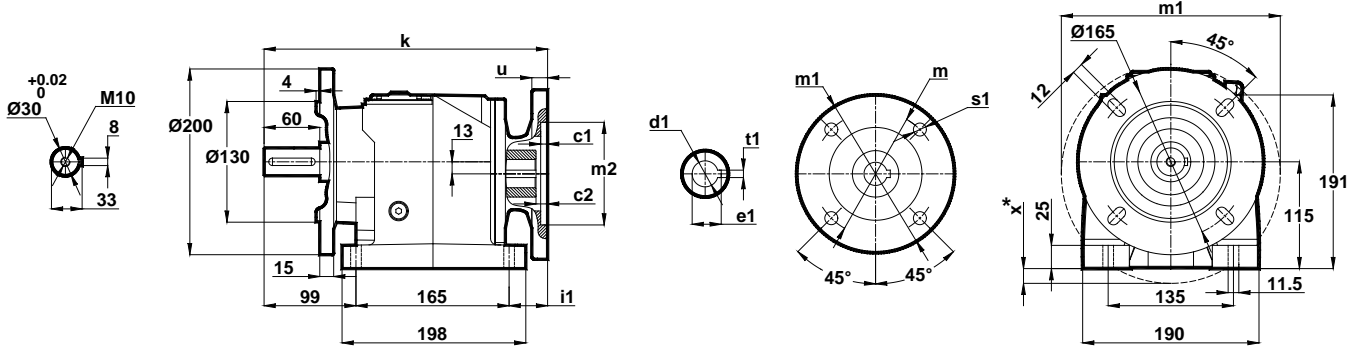

IEC	c1	c2	s1	m	m1	m2	i1	u	k	d1	t1	e1	x
63/B5	4	5	9	115	140	95	58.5	12	323	11	4	12.8	-
71/B5	4	8.5	11	130	160	110	29.5	12	294	14	5	163	-
80/B5	4	5	12	165	200	130	58.5	12	323	19	6	21.8	-
90/B5	4	5	12	165	200	130	58.5	12	323	24	8	27.3	-
100/B5	4	5.5	15	215	250	180	51.5	12	316	28	8	31.3	23
112/B5	4	5.5	15	215	250	180	51.5	12	316	28	8	31.3	23

Opsiyonel Flanş Ölçüleri / Optional Flange Dimensions / Auswählbare Flanschabmessungen

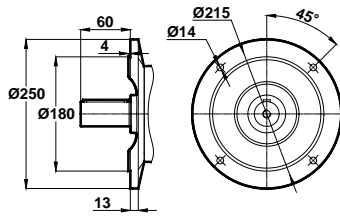

Opt. 1

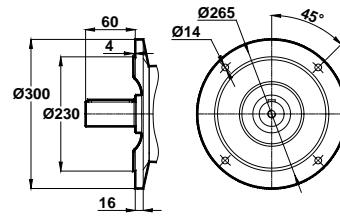

Opt. 2

x: Motor, ayak bağlantı yüzeyinin altında ise / x: If Motor is lower then foot mounting plane / x: Wenn motor ist niedriger den die Anschlußplatte



Ölçü Sayfaları Dimension Pages Abmessungsseiten



-Mil ucu çektirme deliği DIN 332 sayfa 2 / Tapped center hole to DIN 332, sheet 2 / Zentrierung mit gewinde DIN 332, Blatt 2

MNF202-B..
MNF203-B..

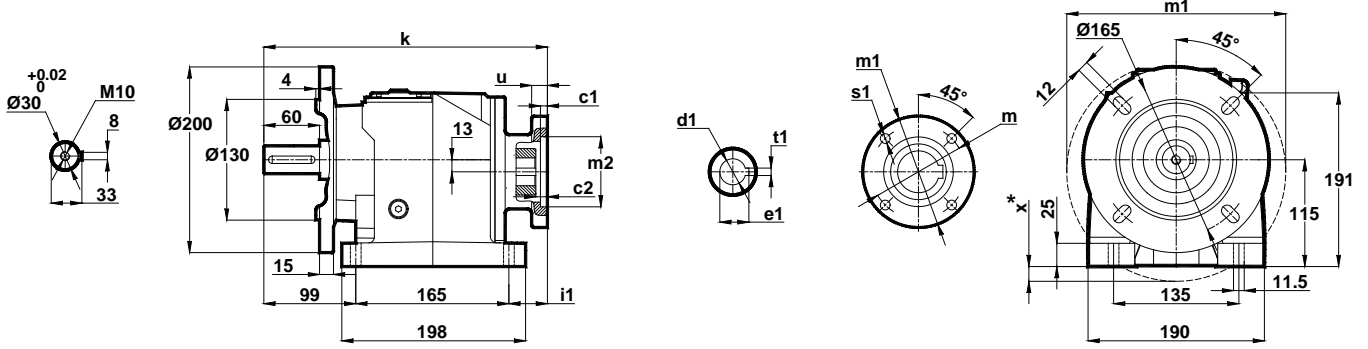

IEC	c1	c2	s1	m	m1	m2	i1	u	k	d1	t1	e1	x
71/B14	3	8.5	7	85	105	70	29.5	10	294	14	5	16.3	-
80/B14	4	5	7	100	120	80	58.5	12	323	19	6	21.8	-
90/B14	4	5	9	115	140	95	58.5	12	323	24	8	27.3	-
100/B14	4	5.5	9	130	160	110	51.5	12	316	28	8	31.3	-
112/B14	4	5.5	9	130	160	110	51.5	12	316	28	8	31.3	-

Opsiyonel Flanş Ölçüleri / Optional Flange Dimensions / Auswählbare Flanschabmessungen

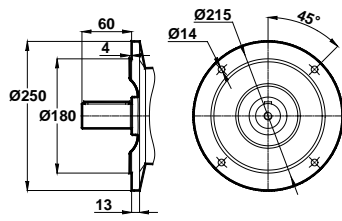

Opt. 1

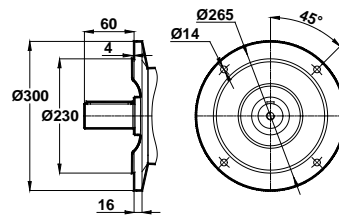

Opt. 2

x: Motor Ayak bağlantı yüzeyinin altında ise / x: If Motor is lower then foot mounting plane / x: Wenn motor ist niedriger den die Anschlußplatte



Ölçü Sayfaları Dimension Pages Abmessungsseiten



-Mil ucu çekirme deliği DIN 332 sayfa 2 / Tapped center hole to DIN 332, sheet 2 / Zentrierung mit gewinde DIN 332, Blatt 2

MNF272-A..
MNF273-A..

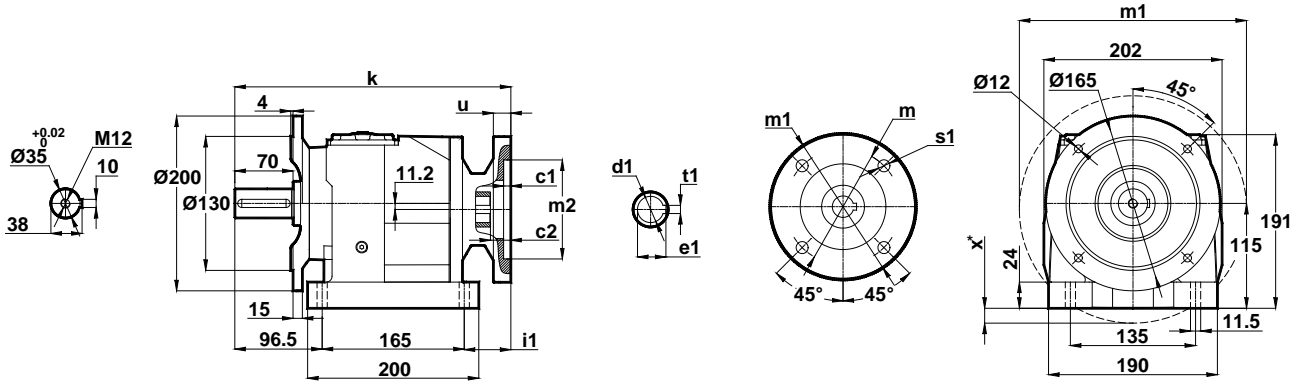

IEC	c1	c2	s1	m	m1	m2	i1	u	k	d1	t1	e1	x
63/B5	4	5	9	115	140	95	62	12	324	11	4	12.8	-
71/B5	4	8.5	11	130	160	110	33	12	295	14	5	16.3	-
80/B5	4	5	12	165	200	130	62	12	324	19	6	21.8	-
90/B5	4	5	12	165	200	130	62	12	324	24	8	27.3	-
100/B5	4	5.5	15	215	250	180	55	12	317	28	8	31.3	22
112/B5	4	5.5	15	215	250	180	55	12	317	28	8	31.3	22

Opsiyonel Flanş Ölçüleri / Optional Flange Dimensions / Auswählbare Flanschabmessungen

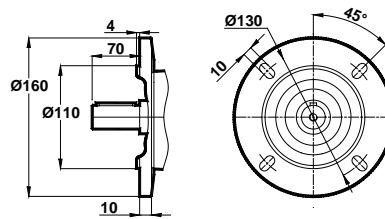

Opt. 1

x: Motor, ayak bağlantı yüzeyinin altında ise / x: If Motor is lower then foot mounting plane / x: Wenn motor ist niedriger den die Anschlußplatte



Ölçü Sayfaları Dimension Pages Abmessungsseiten



-Mil ucu çektirme deliği DIN 332 sayfa 2 / Tapped center hole to DIN 332, sheet 2 / Zentrierung mit gewinde DIN 332, Blatt 2

MNF272-B..
MNF273-B..

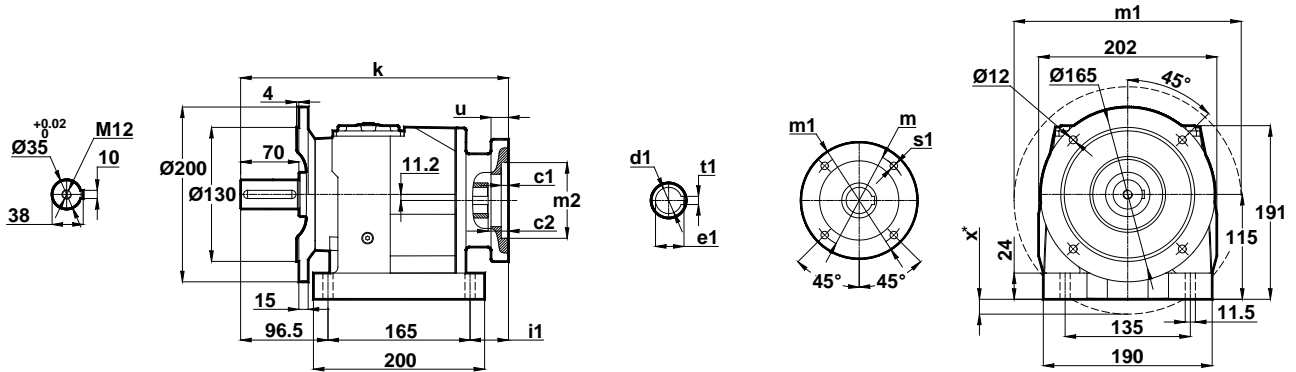

IEC	c1	c2	s1	m	m1	m2	i1	u	k	d1	t1	e1	x
71/B14	3	8.5	7	85	105	70	33	10	295	14	5	16.3	-
80/B14	4	5	7	100	120	80	62	12	324	19	6	21.8	-
90/B14	4	5	9	115	140	95	62	12	324	24	8	27.3	-
100/B14	4	5.5	9	130	160	110	55	12	317	28	8	31.3	-
112/B14	4	5.5	9	130	160	110	55	12	317	28	8	31.3	-

Opsiyonel Flanş Ölçüleri / Optional Flange Dimensions / Auswählbare Flanschabmessungen

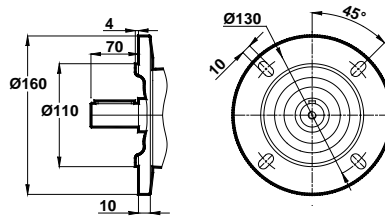

Opt. 1

x: Motor Ayak bağlantı yüzeyinin altında ise / x: If Motor is lower then foot mounting plane / x: Wenn motor ist niedriger den die Anschlußplatte



Ölçü Sayfaları Dimension Pages Abmessungsseiten



-Mil ucu çekirme deliği DIN 332 sayfa 2 / Tapped center hole to DIN 332, sheet 2 / Zentrierung mit gewinde DIN 332, Blatt 2

MNF275-A..
MNF276-A..

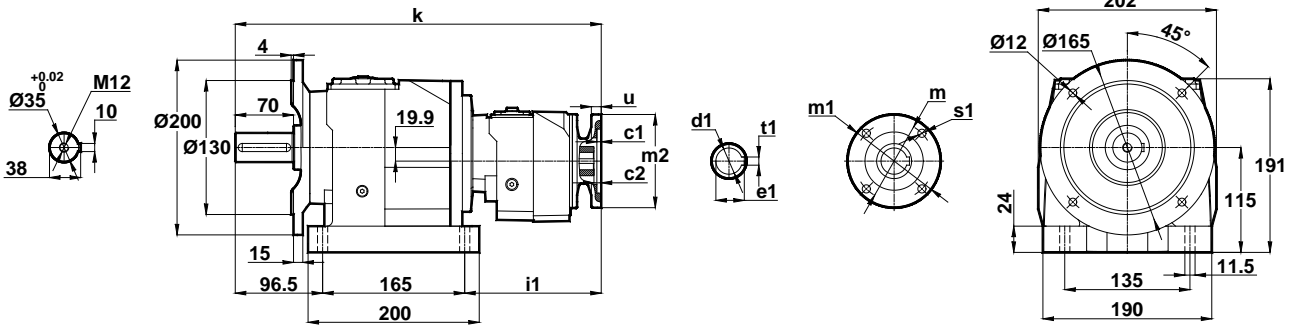

IEC	c1	c2	s1	m	m1	m2	i1	u	k	d1	t1	e1
63/B5	3.5	5	10	115	140	95	177.5	10	439	11	4	12.8
71/B5	4	4.5	11	130	160	110	179	12	441	14	5	16.3

Opsiyonel Flanş Ölçüleri / Optional Flange Dimensions / Auswählbare Flanschabmessungen

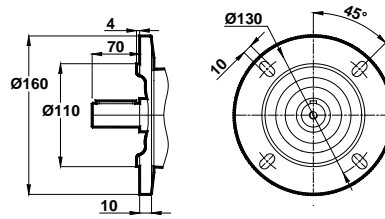

Opt. 1



Ölçü Sayfaları

Dimension Pages

Abmessungsseiten



-Mil ucu çektirme deliği DIN 332 sayfa 2 / Tapped center hole to DIN 332, sheet 2 / Zentrierung mit gewinde DIN 332, Blatt 2

MNF275-B..
MNF276-B..

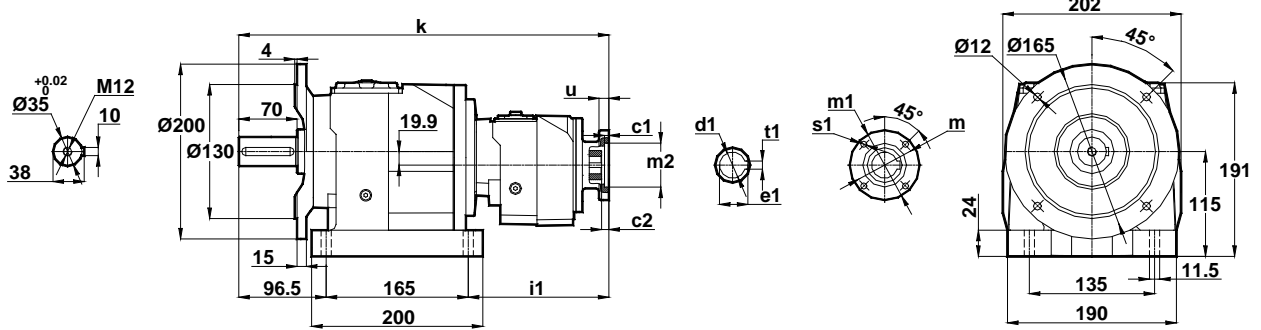

IEC	c1	c2	s1	m	m1	m2	i1	u	k	d1	t1	e1
63/B14	2.5	5	5.5	75	90	60	177.5	10	439	11	4	12.8
71/B14	3	4.5	7	85	105	70	179	10	441	14	5	16.3

Opsiyonel Flanş Ölçüleri / Optional Flange Dimensions / Auswählbare Flanschabmessungen

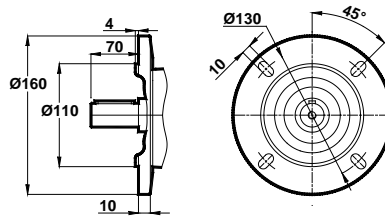

Opt. 1



Ölçü Sayfaları Dimension Pages Abmessungsseiten



-Mil ucu çektirme deliği DIN 332 sayfa 2 / Tapped center hole to DIN 332, sheet 2 / Zentrierung mit gewinde DIN 332, Blatt 2

MNF282-A..
MNF283-A..

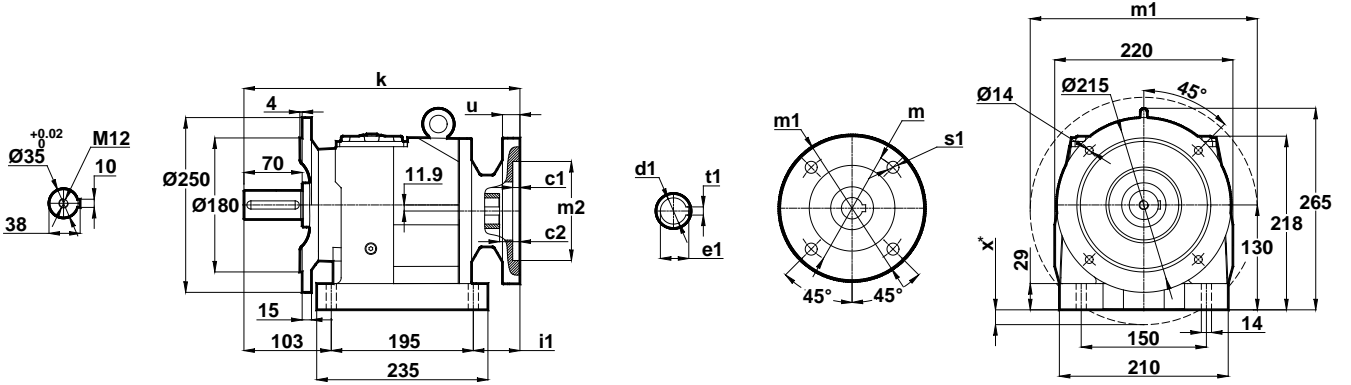

IEC	c1	c2	s1	m	m1	m2	i1	u	k	d1	t1	e1	x
71/B5	4	9	11	130	160	110	45	12	343	14	5	16.3	-
80/B5	4	9	12	165	200	130	45	12	343	19	6	21.8	-
90/B5	4	9	12	165	200	130	45	12	343	24	8	27.3	-
100/B5	4.5	9	15	215	250	180	52	15	350	28	8	31.3	7
112/B5	4.5	9	15	215	250	180	52	15	350	28	8	31.3	7
132/B5	4.5	7	15	265	300	230	82	15	380	38	10	41.3	32

Opsiyonel Flanş Ölçüleri / Optional Flange Dimensions / Auswählbare Flanschabmessungen

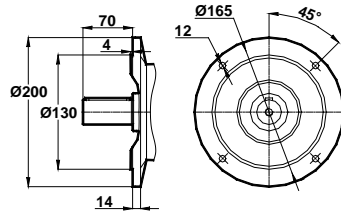

Opt. 1

x: Motor, ayak bağlantı yüzeyinin altında ise / x: If Motor is lower then foot mounting plane / x: Wenn motor ist niedriger den die Anschlußplatte



Ölçü Sayfaları Dimension Pages Abmessungsseiten



-Mil ucu çektirme deliği DIN 332 sayfa 2 / Tapped center hole to DIN 332, sheet 2 / Zentrierung mit gewinde DIN 332, Blatt 2

MNF282-B..
MNF283-B..

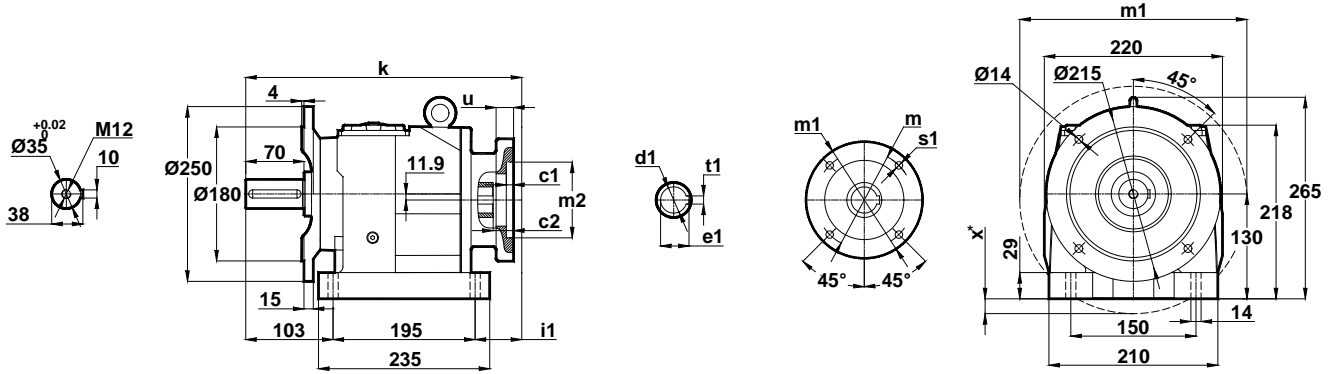

IEC	c1	c2	s1	m	m1	m2	i1	u	k	d1	t1	e1	x
80/B14	4	9	7	100	120	80	45	12	343	19	6	21.8	-
90/B14	4	9	9	115	140	95	45	12	343	24	8	26.3	-
100/B14	4	9	9	130	160	110	52	15	350	28	8	31.3	-
112/B14	4	9	9	130	160	110	52	15	350	28	8	31.3	-
132/B14	4.5	7	11	165	200	130	82	15	380	38	10	41.3	-

Opsiyonel Flanş Ölçüleri / Optional Flange Dimensions / Auswählbare Flanschabmessungen

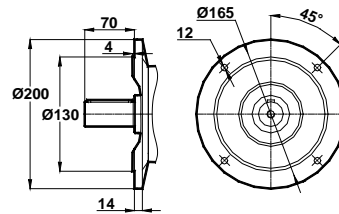

Opt. 1

x: Motor Ayak bağlantı yüzeyinin altında ise / x: If Motor is lower then foot mounting plane / x: Wen motor ist nidriger den die Anschlußplatte



Ölçü Sayfaları Dimension Pages Abmessungenseiten



-Mil ucu çekirme deliği DIN 332 sayfa 2 / Tapped center hole to DIN 332, sheet 2 / Zentrierung mit gewinde DIN 332, Blatt 2

MNF284-A..
MNF284-B..

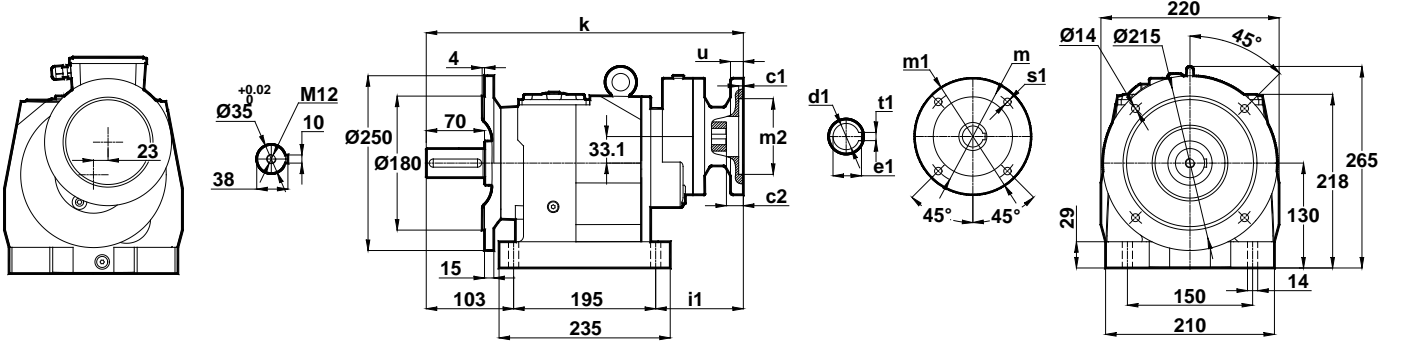

IEC	c1	c2	s1	m	m1	m2	i1	u	k	d1	t1	e1
63/B5	3.5	5	10	115	140	95	122	10	420	11	4	12.8
71/B5	4	4.5	11	130	160	110	93	12	391	14	5	16.3
71/B14	3	4.5	7	85	105	70	93	10	391	14	5	16.3

Opsiyonel Flanş Ölçüleri / Optional Flange Dimensions / Auswählbare Flanschabmessungen

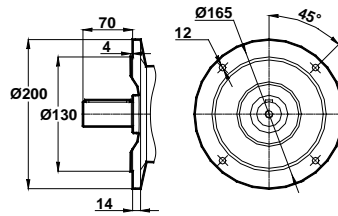

Opt. 1



Ölçü Sayfaları Dimension Pages Abmessungenseiten



-Mil ucu çektirme deliği DIN 332 sayfa 2 / Tapped center hole to DIN 332, sheet 2 / Zentrierung mit gewinde DIN 332, Blatt 2

MNF285-A.. / B..
MNF286-A.. / B..

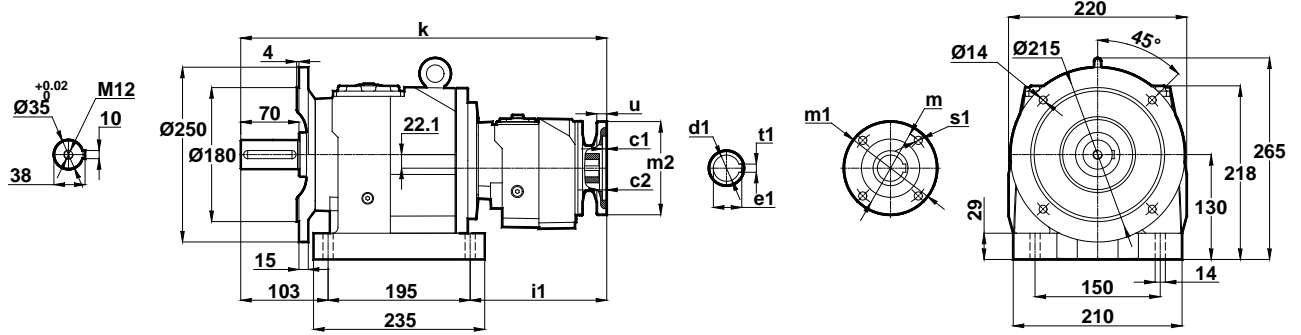

IEC	c1	c2	s1	m	m1	m2	i1	u	k	d1	t1	e1
63/B5	4	7	10	115	140	95	188	12	486	11	4	12.8
63/B14	2.5	5	5.5	75	90	60	188	10	486	11	4	12.8

Opsiyonel Flanş Ölçüleri / Optional Flange Dimensions / Auswählbare Flanschabmessungen

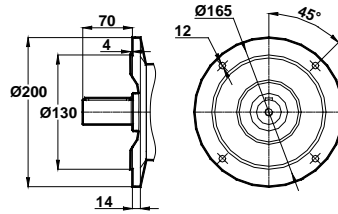

Opt. 1



Ölçü Sayfaları Dimension Pages Abmessungenseiten



-Mil ucu çekirme deliği DIN 332 sayfa 2 / Tapped center hole to DIN 332, sheet 2 / Zentrierung mit gewinde DIN 332, Blatt 2

MNF372-A..
MNF373-A..

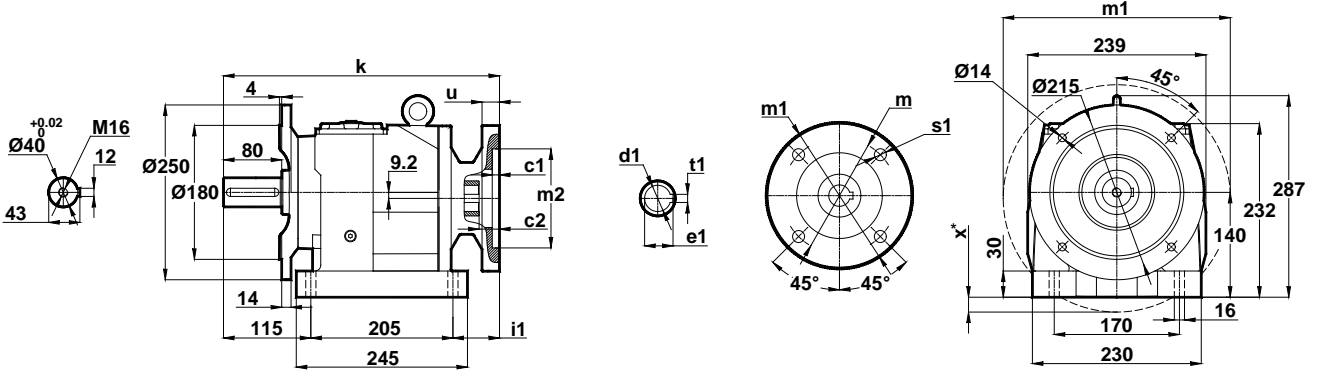

IEC	c1	c2	s1	m	m1	m2	i1	u	k	d1	t1	e1	x
71/B5	4	9	11	130	160	110	43.5	12	364	14	5	16.3	-
80/B5	4	9	12	165	200	130	43.5	12	364	19	6	21.8	-
90/B5	4	9	12	165	200	130	43.5	12	364	24	8	27.3	-
100/B5	4.5	9	15	215	250	180	60.5	15	381	28	8	31.3	-
112/B5	4.5	9	15	215	250	180	60.5	15	381	28	8	31.3	-
132/B5	4.5	7	15	265	300	230	80.5	15	401	38	10	41.3	20

Opsiyonel Flanş Ölçüleri / Optional Flange Dimensions / Auswählbare Flanschabmessungen

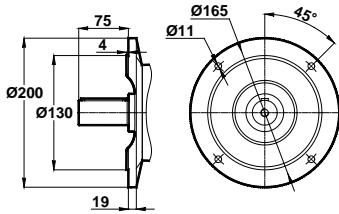

Opt. 1

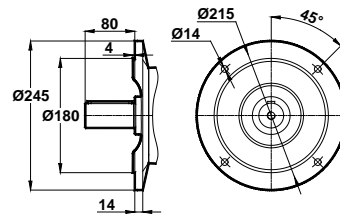

Opt. 2

x: Motor, ayak bağlantı yüzeyinin altında ise / x: If Motor is lower then foot mounting plane / x: Wenn motor ist niedriger den die Anschlußplatte



Ölçü Sayfaları Dimension Pages Abmessungsseiten



-Mil ucu çektirme deliği DIN 332 sayfa 2 / Tapped center hole to DIN 332, sheet 2 / Zentrierung mit gewinde DIN 332, Blatt 2

MNF372-B..
MNF373-B..

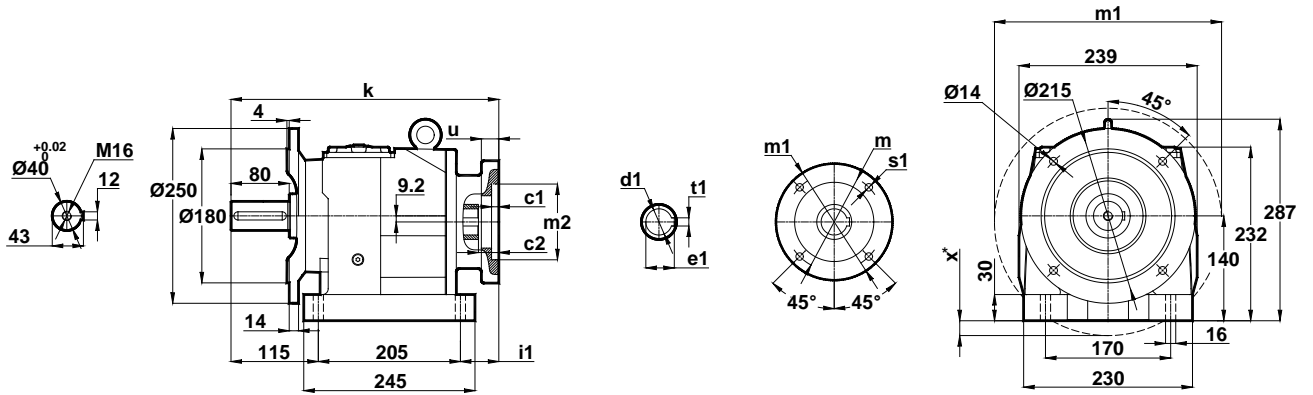

IEC	c1	c2	s1	m	m1	m2	i1	u	k	d1	t1	e1	x
80/B14	4	9	7	100	120	80	43.5	12	364	19	6	21.8	-
90/B14	4	9	9	115	140	95	43.5	12	364	24	8	26.3	-
100/B14	4	9	9	130	160	110	60.5	15	381	28	8	31.3	-
112/B14	4	9	9	130	160	110	60.5	15	381	28	8	31.3	-
132/B14	4.5	9	11	165	200	130	80.5	15	401	38	10	41.3	-

Opsiyonel Flanş Ölçüleri / Optional Flange Dimensions / Auswählbare Flanschabmessungen

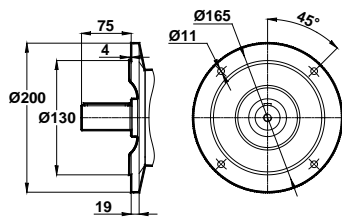

Opt. 1

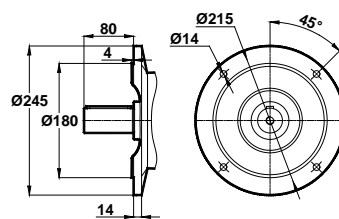

Opt. 2

x: Motor Ayak bağlantı yüzeyinin altında ise / x: If Motor is lower than foot mounting plane / x: Wenn motor ist niedriger den die Anschlußplatte



Ölçü Sayfaları Dimension Pages Abmessungenseiten



-Mil ucu çekirme deliği DIN 332 sayfa 2 / Tapped center hole to DIN 332, sheet 2 / Zentrierung mit gewinde DIN 332, Blatt 2

MNF374-A..
MNF374-B..

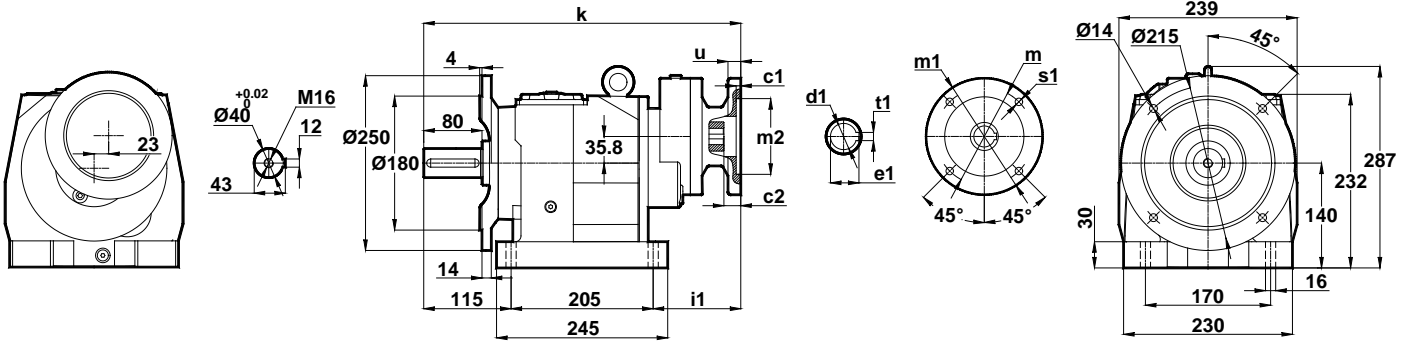

IEC	c1	c2	s1	m	m1	m2	i1	u	k	d1	t1	e1
63/B5	4	5	9	115	140	95	120.5	12	441	11	4	12.8
71/B5	4	8.5	11	130	160	110	91.5	12	412	14	5	16.3
80/B5	4	5	12	165	200	130	120.5	12	441	19	6	21.8
71/B14	3	8.5	7	85	105	70	91.5	10	412	14	5	16.3
80/B14	4	5	7	100	120	80	120.5	12	441	19	6	21.8

Opsiyonel Flanş Ölçüleri / Optional Flange Dimensions / Auswählbare Flanschabmessungen

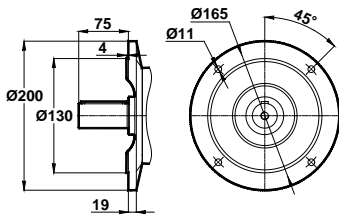

Opt. 1

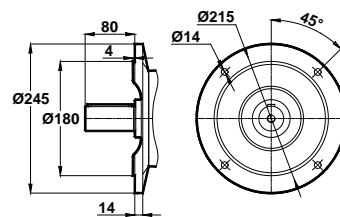

Opt. 2



Ölçü Sayfaları Dimension Pages Abmessungenseiten



-Mil ucu çektirme deliği DIN 332 sayfa 2 / Tapped center hole to DIN 332, sheet 2 / Zentrierung mit gewinde DIN 332, Blatt 2

MNF375-A.. / B..
MNF376-A.. / B..

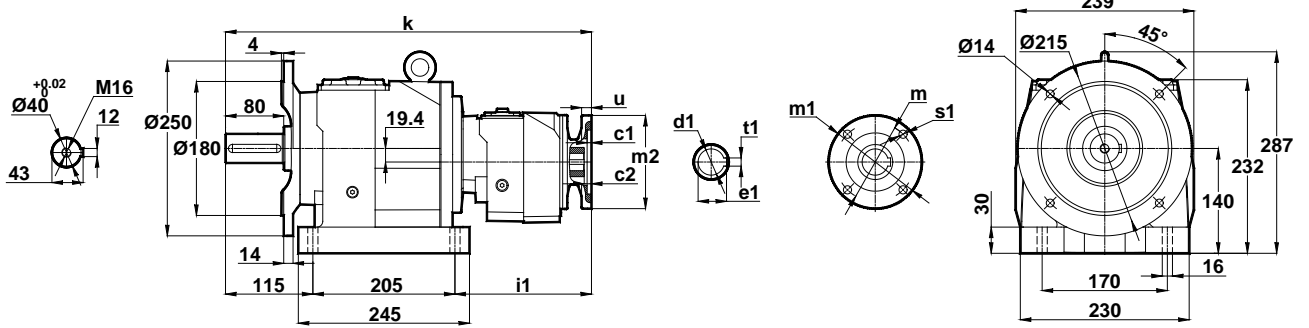

IEC	c1	c2	s1	m	m1	m2	i1	u	k	d1	t1	e1
63/B5	3.5	5	10	115	140	95	186.5	10	507	11	4	12.8
63/B14	2.5	5	5.5	75	90	60	186.5	10	507	11	4	12.8

Opsiyonel Flanş Ölçüleri / Optional Flange Dimensions / Auswählbare Flanschabmessungen

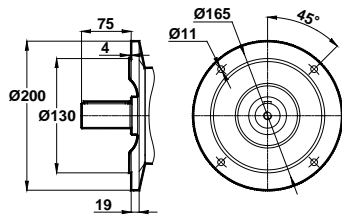

Opt. 1

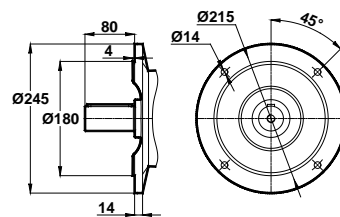

Opt. 2



Ölçü Sayfaları Dimension Pages Abmessungsseiten



-Mil ucu çekirme deliği DIN 332 sayfa 2 / Tapped center hole to DIN 332, sheet 2 / Zentrierung mit gewinde DIN 332, Blatt 2

MNF472-A..
MNF473-A..

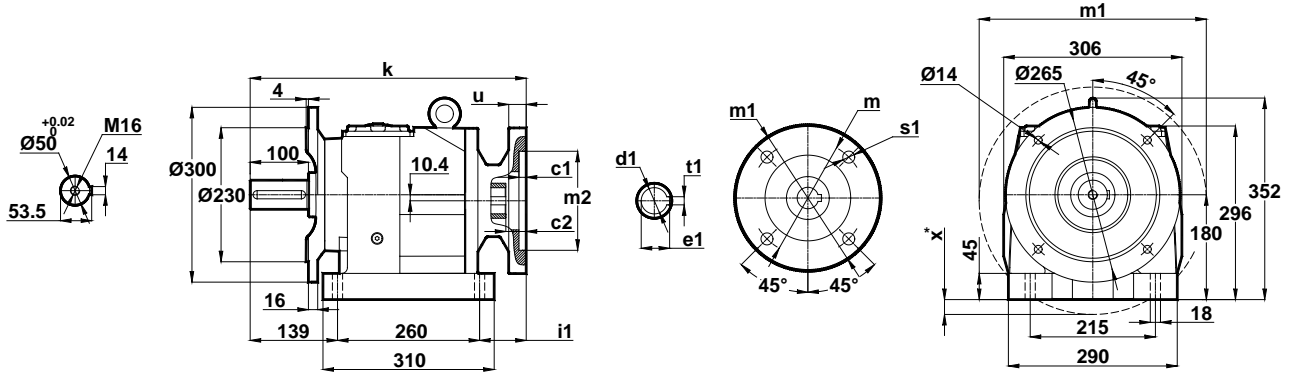

IEC	c1	c2	s1	m	m1	m2	i1	u	k	d1	t1	e1	x
80/B5	4	5	12	165	200	130	27.5	12	427	19	6	21.8	-
90/B5	4	5	12	165	200	130	27.5	12	427	24	8	27.3	-
100/B5	4.5	9	15	215	250	180	46	15	445	28	8	31.3	-
112/B5	4.5	9	15	215	250	180	46	15	445	28	8	31.3	-
132/B5	4.5	6	15	265	300	230	64.5	15	464	38	10	41.3	-
160/B5	5.5	10	19	300	350	250	144	20	543	42	12	45.3	6
180/B5	5.5	10	19	300	350	250	144	20	543	48	14	51.8	6

Opsiyonel Flanş Ölçüleri / Optional Flange Dimensions / Auswählbare Flanschabmessungen

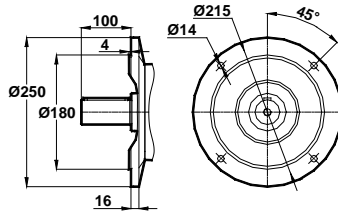

Opt. 1

x: Motor, ayak bağlantı yüzeyinin altında ise / x: If Motor is lower then foot mounting plane / x: Wenn motor ist niedriger den die Anschlußplatte



Ölçü Sayfaları Dimension Pages Abmessungenseiten



-Mil ucu çektirme deliği DIN 332 sayfa 2 / Tapped center hole to DIN 332, sheet 2 / Zentrierung mit gewinde DIN 332, Blatt 2

MNF472-B..
MNF473-B..

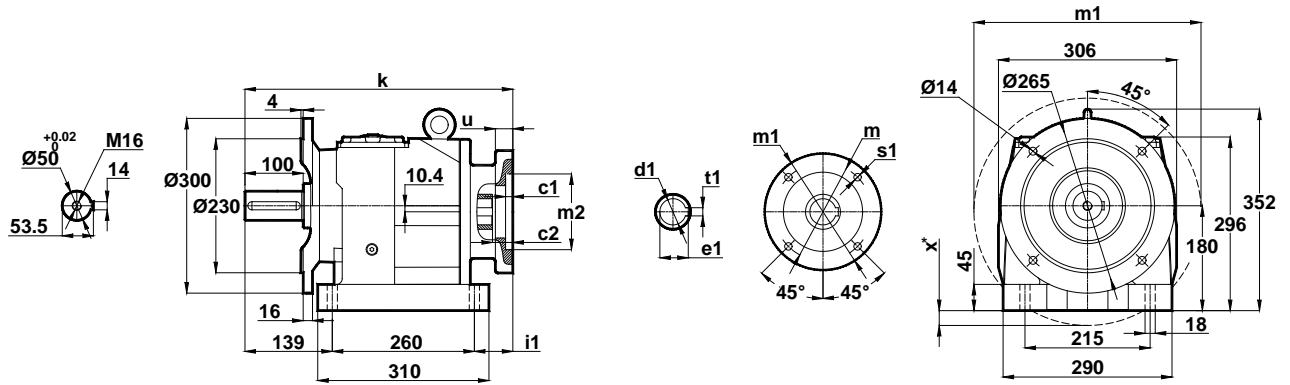

IEC	c1	c2	s1	m	m1	m2	i1	u	k	d1	t1	e1	x
90/B14	4	5	9	115	140	95	27.5	12	427	24	8	27.3	-
100/B14	4	9	9	130	160	110	46	15	445	28	8	31.3	-
112/B14	4	9	9	130	160	110	46	15	445	28	8	31.3	-
132/B14	4.4	6	11	165	200	130	64.5	15	464	38	10	41.3	-

Opsiyonel Flanş Ölçüleri / Optional Flange Dimensions / Auswählbare Flanschabmessungen

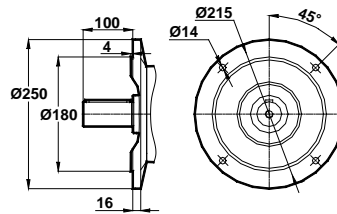

Opt. 1

x: Motor Ayak bağlantı yüzeyinin altında ise / x: If Motor is lower than foot mounting plane / x: Wen motor ist niedriger den die Anschlußplatte



Ölçü Sayfaları

Dimension Pages

Abmessungsseiten



-Mil ucu çekirme deliği DIN 332 sayfa 2 / Tapped center hole to DIN 332, sheet 2 / Zentrierung mit gewinde DIN 332, Blatt 2

MNF474-A..
MNF474-B..

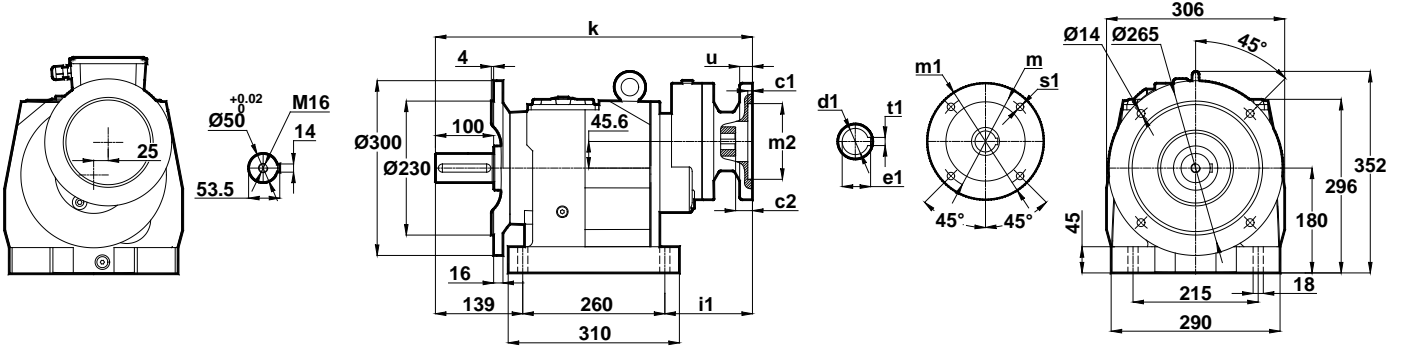

IEC	c1	c2	s1	m	m1	m2	i1	u	k	d1	t1	e1
71/B5	4	9	11	130	160	110	125.5	12	525	14	5	16.3
80/B5	4	9	12	165	200	130	125.5	12	525	19	6	21.8
80/B14	4	9	7	100	120	80	125.5	12	525	19	6	21.8

Opsiyonel Flanş Ölçüleri / Optional Flange Dimensions / Auswählbare Flanschabmessungen

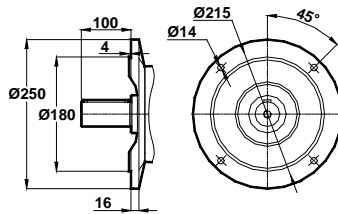

Opt. 1



Ölçü Sayfaları Dimension Pages Abmessungenseiten



-Mil ucu çektirme deliği DIN 332 sayfa 2 / Tapped center hole to DIN 332, sheet 2 / Zentrierung mit gewinde DIN 332, Blatt 2

MNF475-A.. / B..
MNF476-A.. / B..

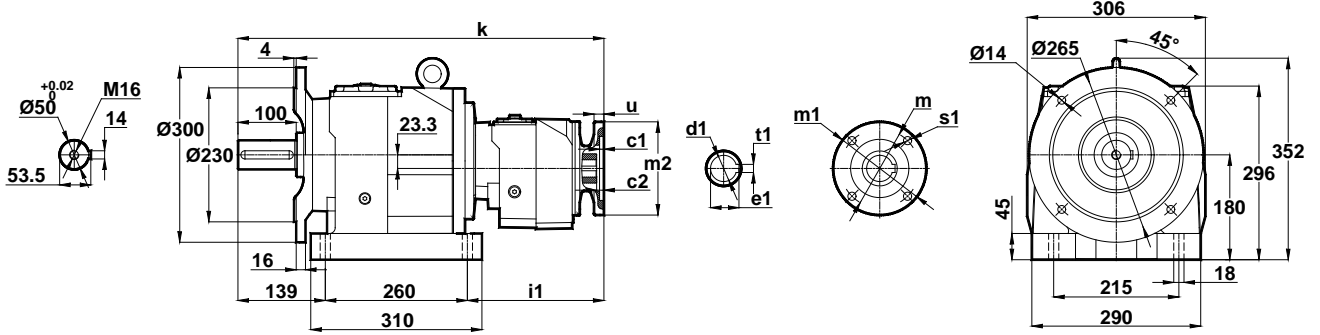

IEC	c1	c2	s1	m	m1	m2	i1	u	k	d1	t1	e1
63/B5	4	5	9	115	140	95	253.5	12	653	11	4	12.8
71/B5	4	8.5	11	130	160	110	224.5	12	624	14	5	16.3
71/B14	3	8.5	7	85	105	70	224.5	10	624	14	5	16.3

Opsiyonel Flanş Ölçüleri / Optional Flange Dimensions / Auswählbare Flanschabmessungen

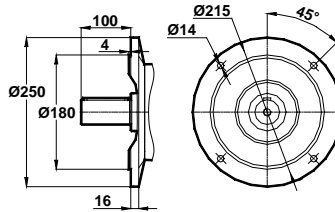

Opt. 1



Ölçü Sayfaları Dimension Pages Abmessungsseiten



-Mil ucu çektirme deliği DIN 332 sayfa 2 / Tapped center hole to DIN 332, sheet 2 / Zentrierung mit gewinde DIN 332, Blatt 2

MVF002 MVF003

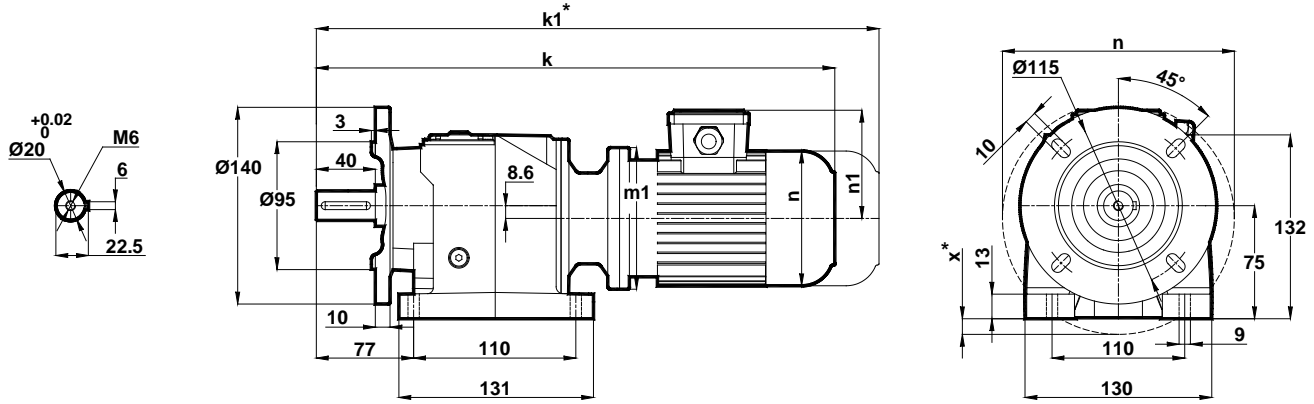

Motor Büyüklüğü / Motor Size / Motorbaugroße					
IEC	63/B5 63/B14	71/B5 71/B14	80/B5 80/B14	90S/B5 90S/B14	90L/B5 90L/B14
k	407	435	470	490	515
k1	460	555	590	615	640
n / n1	121 / 97	138 / 111	156 / 118	176 / 126	176 / 126
m1 (B5)	140	160	200	200	200
m1 (B14)	90	105	120	140	140
x (B5)	4	14	34	34	34

Klemens Kutusu / Terminal Box / Klemmenkasten

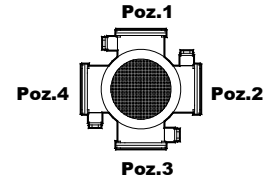

63-71-80-90

Opsiyonel Flanş Ölçüleri / Optional Flange Dimensions / Auswählbare Flanschabmessungen

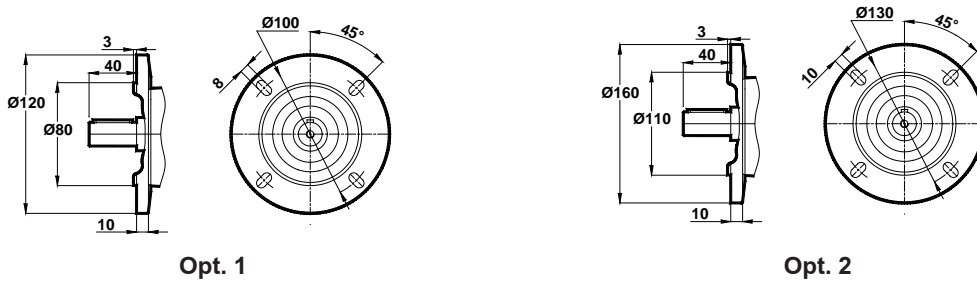

* " k1 " Ölçüsü frenli redüktörlere aittir. 63, 71 tip elektrik motorlu redüktörler soğutmasız, diğerleri soğutmalıdır.
Dimension " k1 " is for motors with brake. Gearboxes with 63 and 71 type electrical motors are not fan cooled, other types are fan cooled.
Maße " k1 " ist für Bremsenmotoren. Getrieben mit 63 und 71 typ Motoren sind ohne Kühlung, andere Typen sind mit Ventilator gekühlt.
x: Motor, ayak bağlantı yüzeyinin altında ise / x: If Motor is lower then foot mounting plane / x: Wenn motor ist niedriger den die Anschlußplatte



Ölçü Sayfaları Dimension Pages Abmessungenseiten



-Mil ucu çektirme deliği DIN 332 sayfa 2 / Tapped center hole to DIN 332, sheet 2 / Zentrierung mit gewinde DIN 332, Blatt 2

MVF102 MVF103

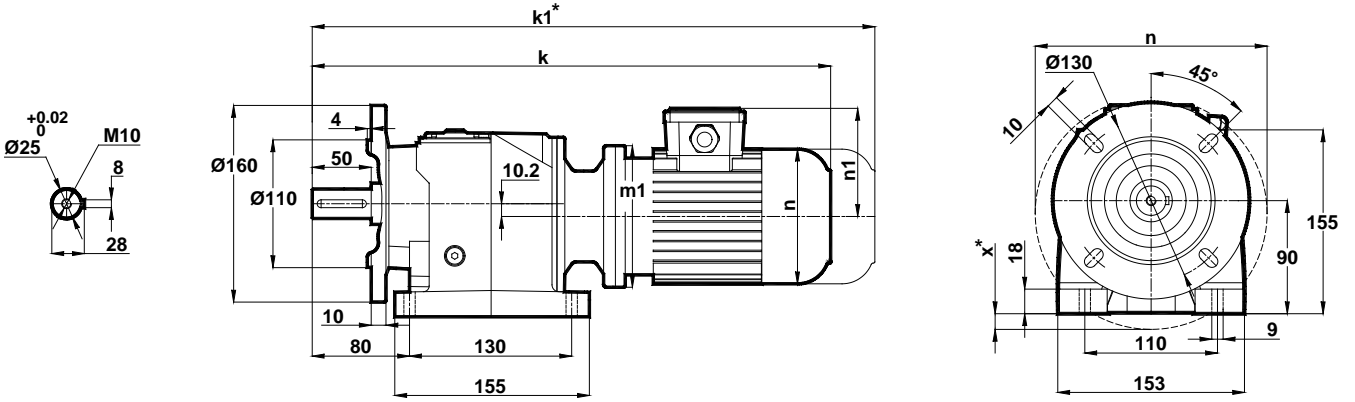

Motor Büyüklüğü / Motor Size / Motorbaugroße					
IEC	63/B5 63/B14	71/B5 71/B14	80/B5 80/B14	90S/B5 90S/B14	90L/B5 90L/B14
k	433	459	494	514	539
k1	486	579	614	639	664
n / n1	121 / 97	138 / 111	156 / 118	176 / 126	176 / 126
m1 (B5)	140	160	200	200	200
m1 (B14)	90	105	120	140	140
x (B5)	-	1	21	21	21

Klemens Kutusu / Terminal Box / Klemmenkasten

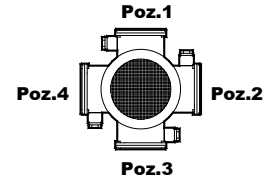

63-71-80-90

Opsiyonel Flanş Ölçüleri / Optional Flange Dimensions / Auswählbare Flanschabmessungen

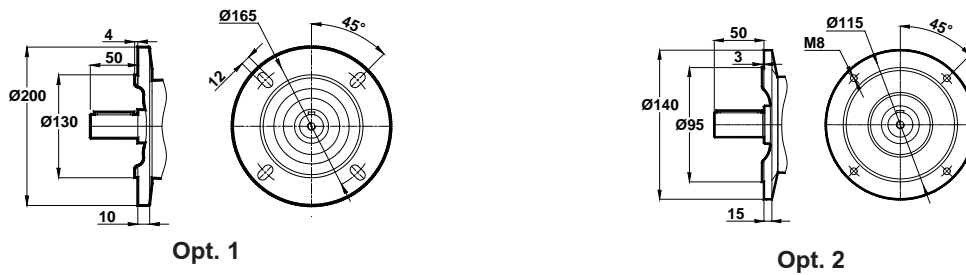

* "k1" Ölçüsü frenli redüktörlere aittir. 63, 71 tip elektrik motorlu redüktörler soğutmasız, diğerleri soğutmalıdır.

Dimension "k1" is for motors with brake. Gearboxes with 63 and 71 type electrical motors are not fan cooled, other types are fan cooled.

Maße "k1" ist für Bremsenmotoren. Getrieben mit 63 und 71 typ Motoren sind ohne Kühlung, andere Typen sind mit Ventilator gekühlt.

x: Motor Ayak bağlantı yüzeyinin altında ise / x: If Motor is lower then foot mounting plane / x: Wenn motor ist niedriger den die Anschlussplatte



Ölçü Sayfaları

Dimension Pages

Abmessungsseiten



-Mil ucu çekirme deliği DIN 332 sayfa 2 / Tapped center hole to DIN 332, sheet 2 / Zentrierung mit gewinde DIN 332, Blatt 2

MVF172
MVF173

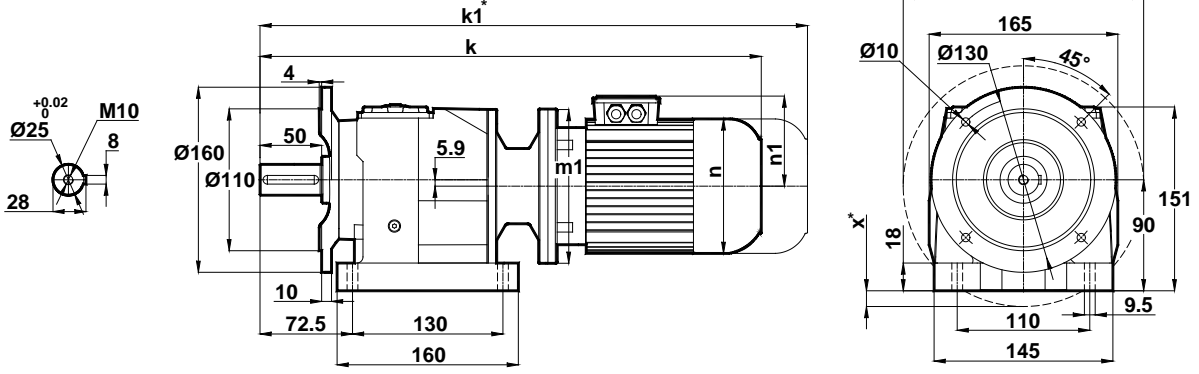

Motor Büyüklüğü / Motor Size / Motorbaugroße							
IEC	63/B5	71/B5 71/B14	80/B5 80/B14	90S/B5 90S/B14	90L/B5 90L/B14	100L/B5 100L/B14	112M/B5 112M/B14
k	434	462	497	517	542	585	605
k1	487	582	617	642	667	720	740
n / n1	121 / 97	138 / 111	156 / 118	176 / 126	176 / 126	194 / 135	218 / 146
m1 (B5)	140	160	200	200	200	250	250
m1 (B14)	-	105	120	140	140	160	160
x (B5)	-	-	16	16	16	41	41

Klemens Kutusu / Terminal Box / Klemmenkasten

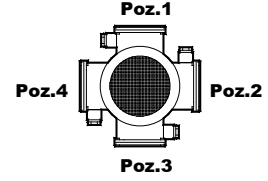

63-71-80-90-100-112

Opsiyonel Flanş Ölçüleri / Optional Flange Dimensions / Auswählbare Flanschabmessungen

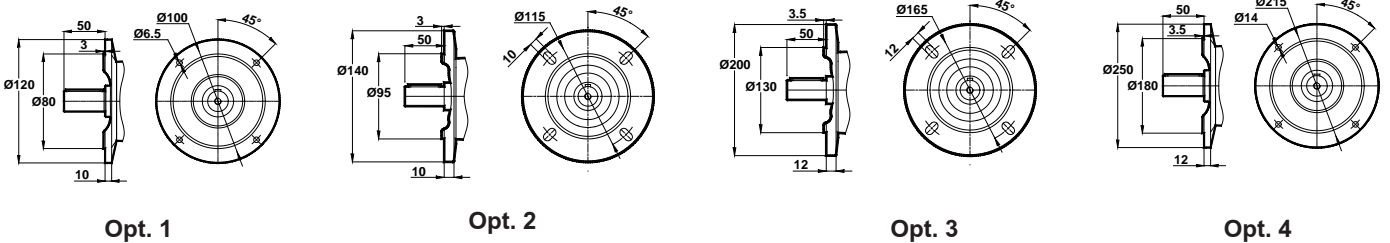

* " k1 " Ölçüsü frenli redüktörlere aittir. 63, 71 tip elektrik motorlu redüktörler soğutmasız, diğerleri soğutmalıdır.
Dimension " k1 " is for motors with brake. Gearboxes with 63 and 71 type electrical motors are not fan cooled, other types are fan cooled.
Maße " k1 " ist für Bremsenmotoren. Getrieben mit 63 und 71 typ Motoren sind ohne Kühlung, andere Typen sind mit Ventilator gekühlt.
x: Motor, ayak bağlantı yüzeyinin altında ise / x: If Motor is lower then foot mounting plane / x: Wenn motor ist niedriger den die Anschlußplatte



Ölçü Sayfaları Dimension Pages Abmessungenseiten



-Mil ucu çekirtme deliği DIN 332 sayfa 2 / Tapped center hole to DIN 332, sheet 2 / Zentrierung mit gewinde DIN 332, Blatt 2

MVF202 MVF203

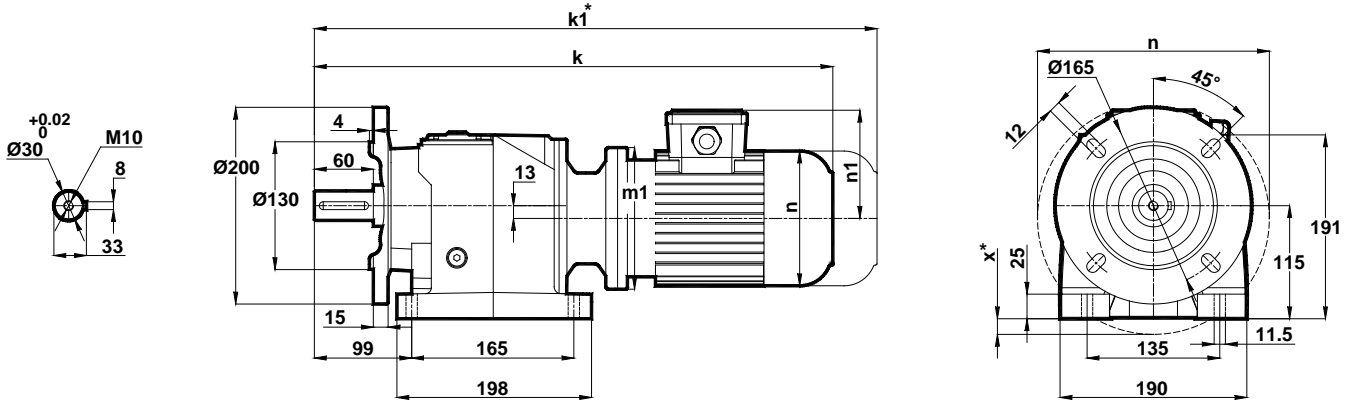

Motor Büyüklüğü / Motor Size / Motorbaugroße							
IEC	63/B5	71/B5 71/B14	80/B5 80/B14	90S/B5 90S/B14	90L/B5 90L/B14	100L/B5 100L/B14	112M/B5 112M/B14
k	516	513	562	582	607	632	652
k1	569	633	682	707	732	767	787
n / n1	121 / 97	138 / 111	156 / 118	176 / 126	176 / 126	194 / 135	218 / 146
m1 (B5)	140	160	200	200	200	250	250
m1 (B14)	-	105	120	140	140	160	160
x (B5)	-	-	-	-	-	23	23

Klemens Kutusu / Terminal Box / Klemmenkasten

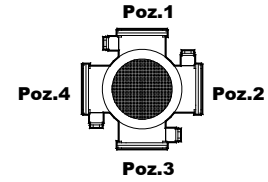

63-71-80-90-100-112

Opsiyonel Flanş Ölçüleri / Optional Flange Dimensions / Auswählbare Flanschabmessungen

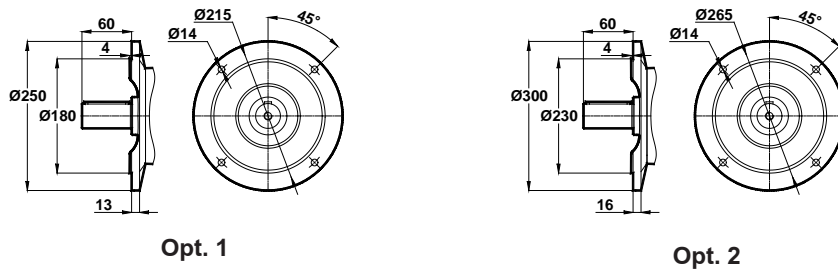

* " k1 " Ölçüsü frenli redüktörlere aittir. 63, 71 tip elektrik motorlu redüktörler soğutmasız, diğerleri soğutmalıdır.

Dimension " k1 " is for motors with brake. Gearboxes with 63 and 71 type electrical motors are not fan cooled, other types are fan cooled.

Maße " k1 " ist für Bremsenmotoren. Getrieben mit 63 und 71 typ Motoren sind ohne Kühlung, andere Typen sind mit Ventilator gekühlt.

x: Motor Ayak bağlantı yüzeyinin altında ise / x: If Motor is lower than foot mounting plane / x: Wenn motor ist niedriger den die Anschlußplatte



Ölçü Sayfaları Dimension Pages Abmessungsseiten



-Mil ucu çektirme deliği DIN 332 sayfa 2 / Tapped center hole to DIN 332, sheet 2 / Zentrierung mit gewinde DIN 332, Blatt 2

MVF272
MVF273

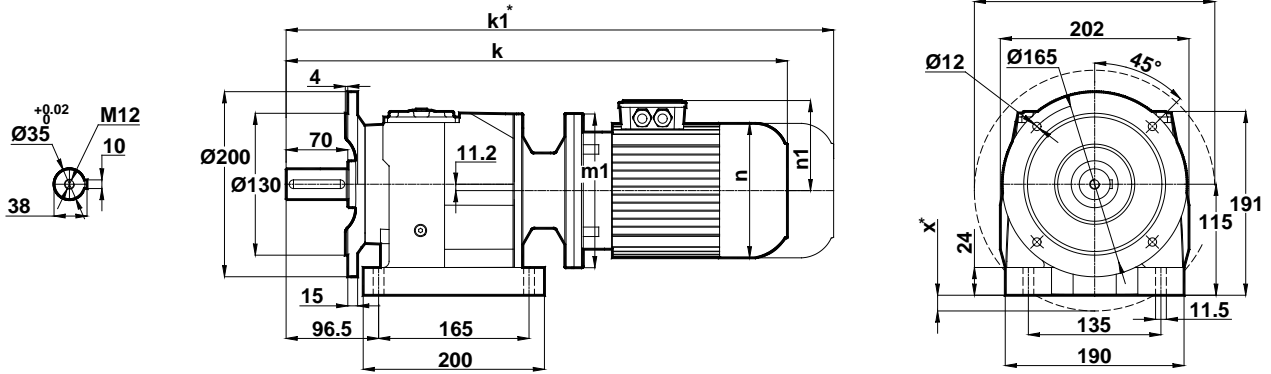

Motor Büyüklüğü / Motor Size / Motorbaugroße							
IEC	63/B5	71/B5 71/B14	80/B5 80/B14	90S/B5 90S/B14	90L/B5 90L/B14	100L/B5 100L/B14	112M/B5 112M/B14
k	517	514	563	583	608	633	653
k1	570	634	683	708	733	768	788
n / n1	121 / 97	138 / 111	156 / 118	176 / 126	176 / 126	194 / 135	218 / 146
m1 (B5)	140	160	200	200	200	250	250
m1 (B14)	-	105	120	140	140	160	160
x (B5)	-	-	-	-	-	22	22

Klemens Kutusu / Terminal Box / Klemmenkasten

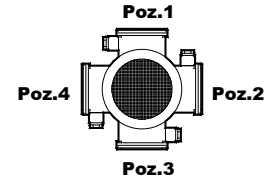

63-71-80-90-100-112

Opsiyonel Flanş Ölçüleri / Optional Flange Dimensions / Auswählbare Flanschabmessungen

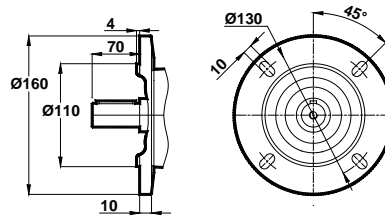

Opt. 1

* "k1" Ölçüsü frenli redüktörlere aittir. 63, 71 tip elektrik motorlu redüktörler soğutmasız, diğerleri soğutmalıdır.

Dimension "k1" is for motors with brake. Gearboxes with 63 and 71 type electrical motors are not fan cooled, other types are fan cooled.

Maße "k1" ist für Bremsenmotoren. Getrieben mit 63 und 71 typ Motoren sind ohne Kühlung, andere Typen sind mit Ventilator gekühlt.

x: Motor, ayak bağlantı yüzeyinin altında ise / x: If Motor is lower than foot mounting plane / x: Wenn motor ist niedriger den die Anschlußplatte



Ölçü Sayfaları

Dimension Pages

Abmessungsseiten



-Mil ucu çektirme deliği DIN 332 sayfa 2 / Tapped center hole to DIN 332, sheet 2 / Zentrierung mit gewinde DIN 332, Blatt 2

MVF275
MVF276

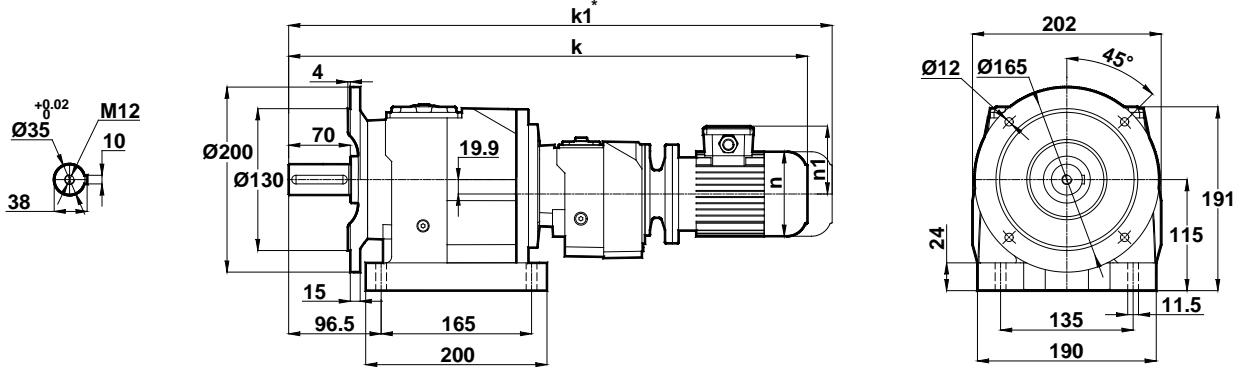

Motor Büyüklüğü / Motor Size / Motorbaugroße		
IEC	63/B5 63/B14	71/B5 71/B14
k	632	660
k1	685	780
n / n1	121 / 97	138 / 111
m1 (B5)	140	160
m1 (B14)	90	105

Klemens Kutusu / Terminal Box / Klemmenkasten

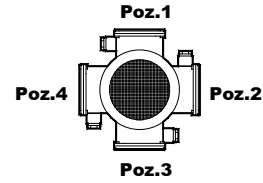

63-71

Opsiyonel Flanş Ölçüleri / Optional Flange Dimensions / Auswählbare Flanschabmessungen

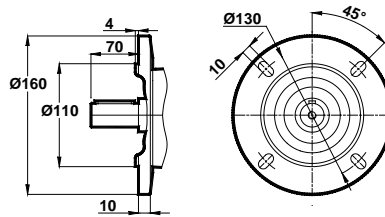

Opt. 1

* " k1 " Ölçüsü frenli redüktörlere aittir. 63, 71 tip elektrik motorlu redüktörler soğutmasız, diğerleri soğutmalıdır.

Dimension " k1 " is for motors with brake. Gearboxes with 63 and 71 type electrical motors are not fan cooled, other types are fan cooled.

Maße " k1 " ist für Bremsenmotoren. Getrieben mit 63 und 71 typ Motoren sind ohne Kühlung, andere Typen zind mit Ventilator gekühlt.



Ölçü Sayfaları Dimension Pages Abmessungsseiten



-Mil ucu çektirme deliği DIN 332 sayfa 2 / Tapped center hole to DIN 332, sheet 2 / Zentrierung mit gewinde DIN 332, Blatt 2

MVF282 MVF283

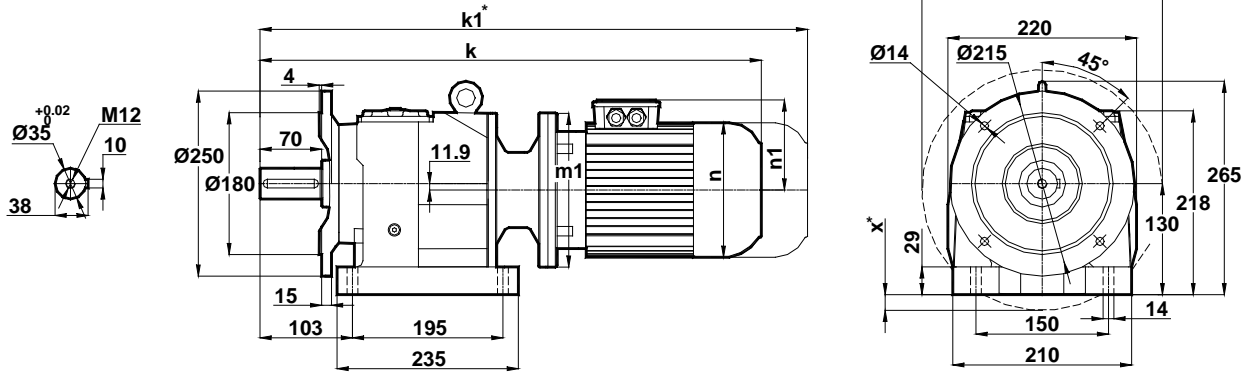

Motor Büyüklüğü / Motor Size / Motorbaugroße								
IEC	71/B5	80/B5 80/B14	90S/B5 90S/B14	90L/B5 90L/B14	100L/B5 100L/B14	112M/B5 112M/B14	132S/B5 132S/B14	132M/B5 132M/B14
k	562	582	602	627	666	686	760	798
k1	682	702	727	752	801	821	905	943
n / n1	138 / 111	156 / 118	176 / 126	176 / 126	194 / 135	218 / 146	257 / 168	257 / 168
m1 (B5)	160	200	200	200	250	250	300	300
m1 (B14)	-	120	140	140	160	160	200	200
x (B5)	-	-	-	-	7	7	32	32

Klemens Kutusu / Terminal Box / Klemmenkasten

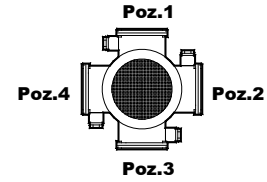

71-80-90-100-112-132

Opsiyonel Flanş Ölçüleri / Optional Flange Dimensions / Auswählbare Flanschabmessungen

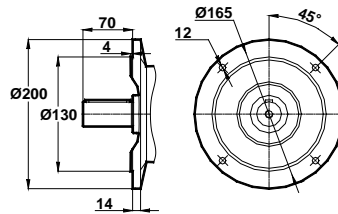

Opt. 1

* " k1 " Ölçüsü frenli redüktörlere aittir. 63, 71 tip elektrik motorlu redüktörler soğutmasız, diğerleri soğutmalıdır.

Dimension " k1 " is for motors with brake. Gearboxes with 63 and 71 type electrical motors are not fan cooled, other types are fan cooled.

Maße " k1 " ist für Bremsenmotoren. Getrieben mit 63 und 71 typ Motoren sind ohne Kühlung, andere Typen sind mit Ventilator gekühlt.

x: Motor, ayak bağlantı yüzeyinin altında ise / x: If Motor is lower then foot mounting plane / x: Wenn motor ist niedriger den die Anschlußplatte



Ölçü Sayfaları Dimension Pages Abmessungsseiten



-Mil ucu çektirme deliği DIN 332 sayfa 2 / Tapped center hole to DIN 332, sheet 2 / Zentrierung mit gewinde DIN 332, Blatt 2

MVF284

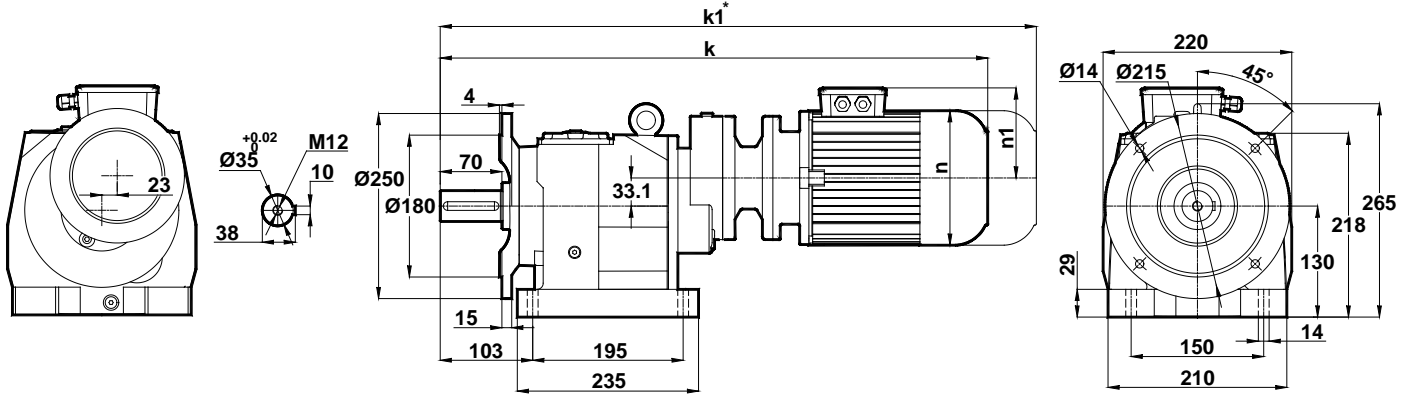

Motor Büyüklüğü / Motor Size / Motorbaugroße		
IEC	63/B5	71/B5 71/B14
k	613	610
k1	666	730
n / n1	121 / 97	138 / 111
m1 (B5)	140	160
m1 (B14)	-	105

Klemens Kutusu / Terminal Box / Klemmenkasten

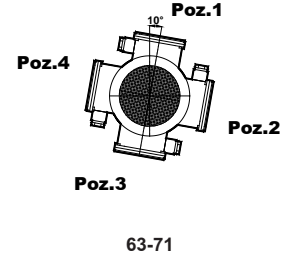

Opsiyonel Flanş Ölçüleri / Optional Flange Dimensions / Auswählbare Flanschabmessungen

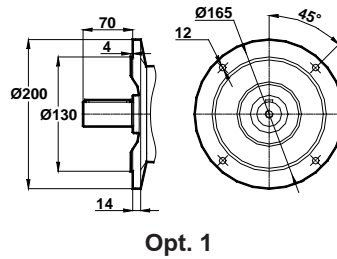

* " k1 " Ölçüsü frenli redüktörlere aittir. 63, 71 tip elektrik motorlu redüktörler soğutmasız, diğerleri soğutmalıdır.

Dimension " k1 " is for motors with brake. Gearboxes with 63 and 71 type electrical motors are not fan cooled, other types are fan cooled.
Maße " k1 " ist für Bremsenmotoren. Getrieben mit 63 und 71 typ Motoren sind ohne Kühlung, andere Typen sind mit Ventilator gekühlt.



Ölçü Sayfaları Dimension Pages Abmessungsseiten



-Mil ucu çekirme deliği DIN 332 sayfa 2 / Tapped center hole to DIN 332, sheet 2 / Zentrierung mit gewinde DIN 332, Blatt 2

MVF372
MVF373

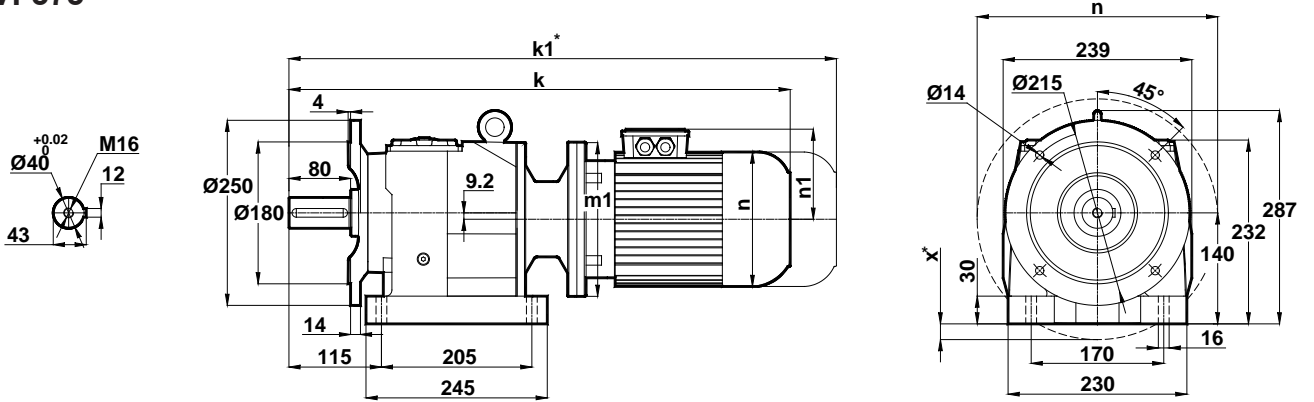

Motor Büyüklüğü / Motor Size / Motorbaugroße								
IEC	71/B5	80/B5 80/B14	90S/B5 90S/B14	90L/B5 90L/B14	100L/B5 100L/B14	112M/B5 112M/B14	132S/B5 132S/B14	132M/B5 132M/B14
k	583	603	623	648	697	717	781	819
k1	703	723	748	773	832	852	926	964
n / n1	138 / 111	156 / 118	176 / 126	176 / 126	194 / 135	218 / 146	257 / 168	257 / 168
m1 (B5)	160	200	200	200	250	250	300	300
m1 (B14)	-	120	140	140	160	160	200	200
x (B5)	-	-	-	-	-	-	20	20

Klemens Kutusu / Terminal Box / Klemmenkasten

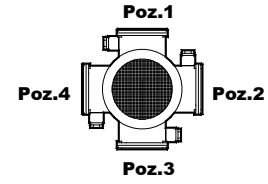

71-80-90-100-112-132

Opsiyonel Flanş Ölçüleri / Optional Flange Dimensions / Auswählbare Flanschabmessungen

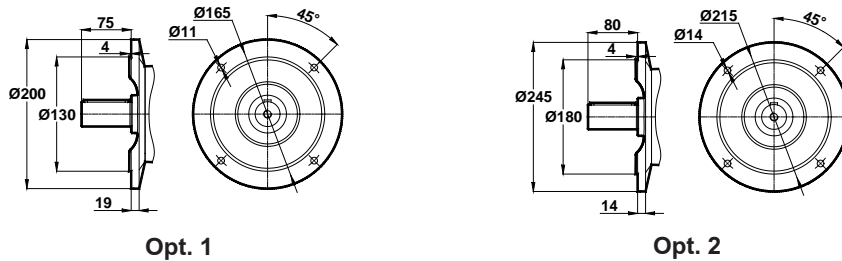

Opt. 1

Opt. 2

* " k1 " Ölçüsü frenli redüktörlere aittir. 63, 71 tip elektrik motorlu redüktörler soğutmasız, diğerleri soğutmalıdır.

Dimension " k1 " is for motors with brake. Gearboxes with 63 and 71 type electrical motors are not fan cooled, other types are fan cooled.

Maße " k1 " ist für Bremsenmotoren. Getrieben mit 63 und 71 typ Motoren sind ohne Kühlung, andere Typen sind mit Ventilator gekühlt.

x: Motor, ayak bağlantı yüzeyinin altında ise / x: If Motor is lower then foot mounting plane / x: Wenn motor ist niedriger den die Anschlussplatte



Ölçü Sayfaları Dimension Pages Abmessungsseiten



-Mil ucu çektirme deliği DIN 332 sayfa 2 / Tapped center hole to DIN 332, sheet 2 / Zentrierung mit gewinde DIN 332, Blatt 2

MVF374

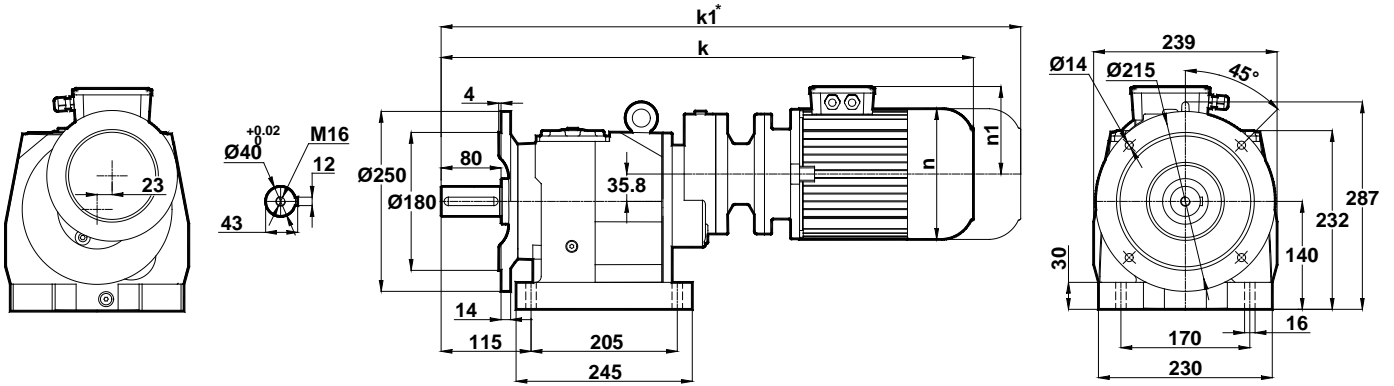

Motor Büyüklüğü / Motor Size / Motorbaugroße			
IEC	63/B5	71/B5 71/B14	80/B5 80/B14
k	634	631	680
k1	687	751	800
n / n1	121 / 97	138 / 111	156 / 118
m1 (B5)	140	160	200
m1 (B14)	-	105	120

Klemens Kutusu / Terminal Box / Klemmenkasten

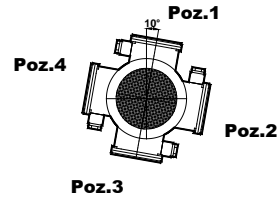

63-71-80

Opsiyonel Flanş Ölçüleri / Optional Flange Dimensions / Auswählbare Flanschabmessungen

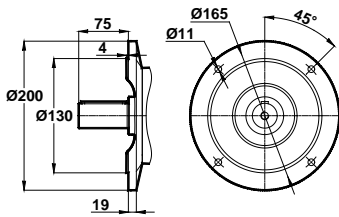

Opt. 1

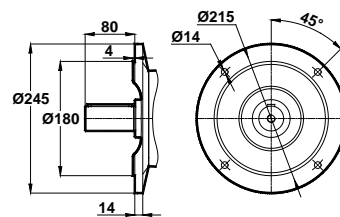

Opt. 2

* " k1 " Ölçüsü frenli redüktörlere aittir. 63, 71 tip elektrik motorlu redüktörler soğutmasız, diğerleri soğutmalıdır.
Dimension " k1 " is for motors with brake. Gearboxes with 63 and 71 type electrical motors are not fan cooled, other types are fan cooled.
Maße " k1 " ist für Bremsenmotoren. Getrieben mit 63 und 71 typ Motoren sind ohne Kühlung, andere Typen sind mit Ventilator gekühlt.



Ölçü Sayfaları Dimension Pages Abmessungenseiten



-Mil ucu çektirme deliği DIN 332 sayfa 2 / Tapped center hole to DIN 332, sheet 2 / Zentrierung mit gewinde DIN 332, Blatt 2

MVF375
MVF376

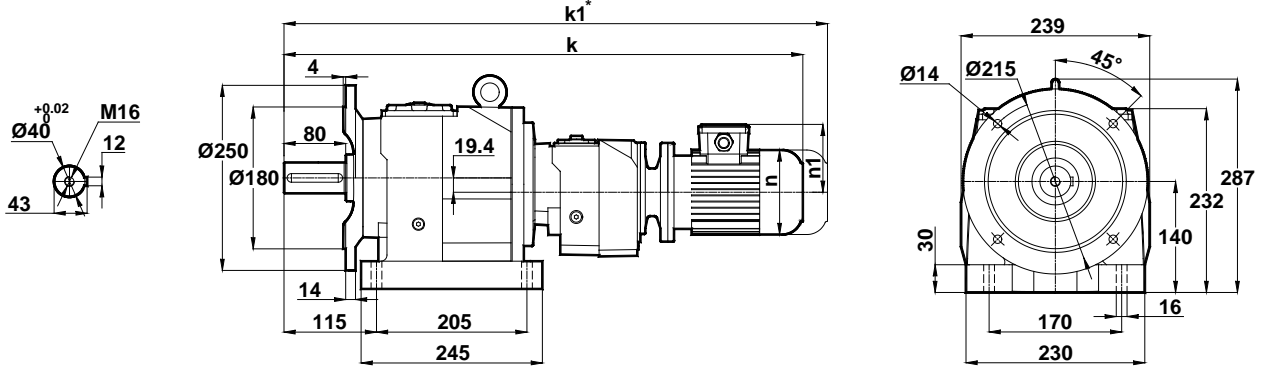

Motor Büyüklüğü / Motor Size / Motorbaugroße	
IEC	63/B5 63/B14
k	700
k1	753
n / n1	121 / 97
m1 (B5)	140
m1 (B14)	90

Klemens Kutusu / Terminal Box / Klemmenkasten

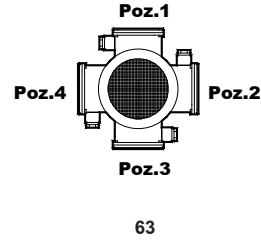

Opsiyonel Flanş Ölçüleri / Optional Flange Dimensions / Auswählbare Flanschabmessungen

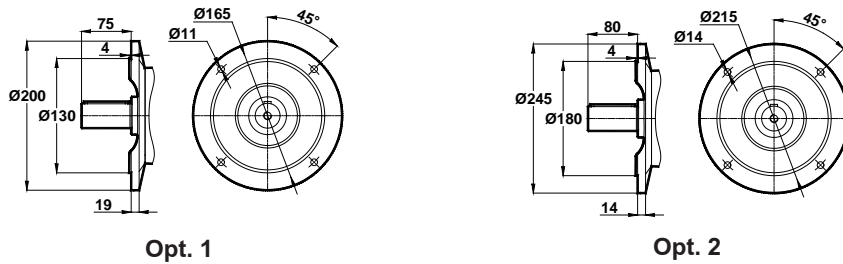

* " k1 " Ölçüsü frenli redüktörlere aittir. 63, 71 tip elektrik motorlu redüktörler soğutmasız, diğerleri soğutmalıdır.
Dimension " k1 " is for motors with brake. Gearboxes with 63 and 71 type electrical motors are not fan cooled, other types are fan cooled.
Maße " k1 " ist für Bremsenmotoren. Getrieben mit 63 und 71 typ Motoren sind ohne Kühlung, andere Typen sind mit Ventilator gekühlt.



Ölçü Sayfaları Dimension Pages Abmessungsseiten



-Mil ucu çektirme deliği DIN 332 sayfa 2 / Tapped center hole to DIN 332, sheet 2 / Zentrierung mit gewinde DIN 332, Blatt 2

MVF472
MVF473

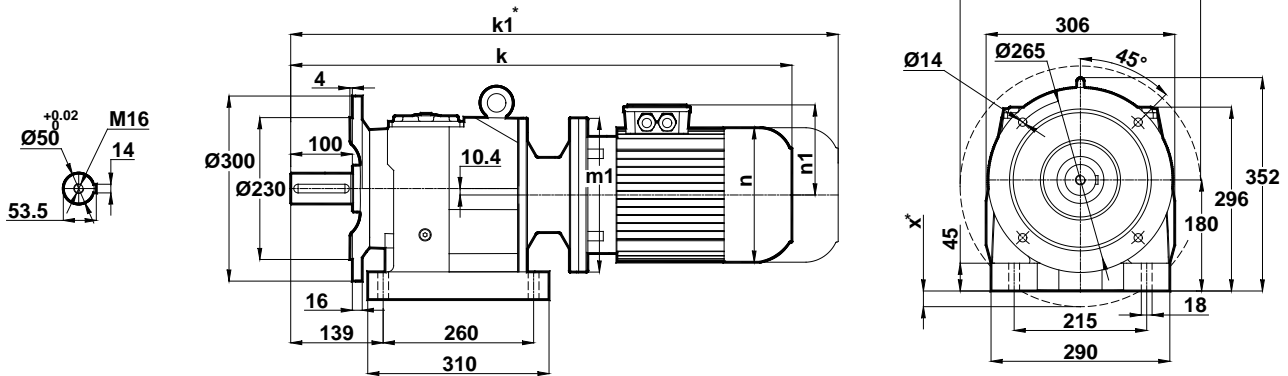

Motor Büyüklüğü / Motor Size / Motorbaugröße											
IEC	80/B5	90S/B5 90S/B14	90L/B5 90L/B14	100L/B5 100L/B14	112M/B5 112M/B14	132S/B5 132S/B14	132M/B5 132M/B14	160M/B5	160L/B5	180M/B5	180L/B5
k	666	686	711	761	781	844	882	1033	1077	1090	1128
k1	786	811	836	896	916	989	1027	1203	1247	1260	1298
n / n1	156 / 118	176 / 126	176 / 126	194 / 135	218 / 146	257 / 168	257 / 168	310 / 225	310 / 225	348 / 241	348 / 241
m1 (B5)	200	200	200	250	250	300	300	350	350	350	350
m1 (B14)	-	140	140	160	160	200	200	-	-	-	-
x (B5)	-	-	-	-	-	-	-	6	6	6	6

Klemens Kutusu / Terminal Box / Klemmenkasten

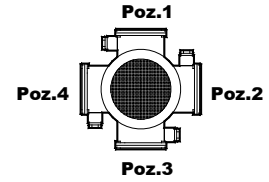

80-90-100-112-132-160-180

Opsiyonel Flanş Ölçüleri / Optional Flange Dimensions / Auswählbare Flanschabmessungen

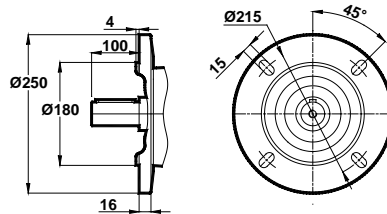

Opt. 1

* " k1 " Ölçüsü frenli redüktörlere aittir. 63, 71 tip elektrik motorlu redüktörler soğutmasız, diğerleri soğutmalıdır.

Dimension " k1 " is for motors with brake. Gearboxes with 63 and 71 type electrical motors are not fan cooled, other types are fan cooled.

Maße " k1 " ist für Bremsenmotoren. Getrieben mit 63 und 71 typ Motoren sind ohne Kühlung, andere Typen sind mit Ventilator gekühlt.

x: Motor, ayak bağlantı yüzeyinin altında ise / x: If Motor is lower then foot mounting plane / x: Wenn motor ist niedriger den die Anschlußplatte



Ölçü Sayfaları Dimension Pages Abmessungsseiten



-Mil ucu çektirme deliği DIN 332 sayfa 2 / Tapped center hole to DIN 332, sheet 2 / Zentrierung mit gewinde DIN 332, Blatt 2

MVF474

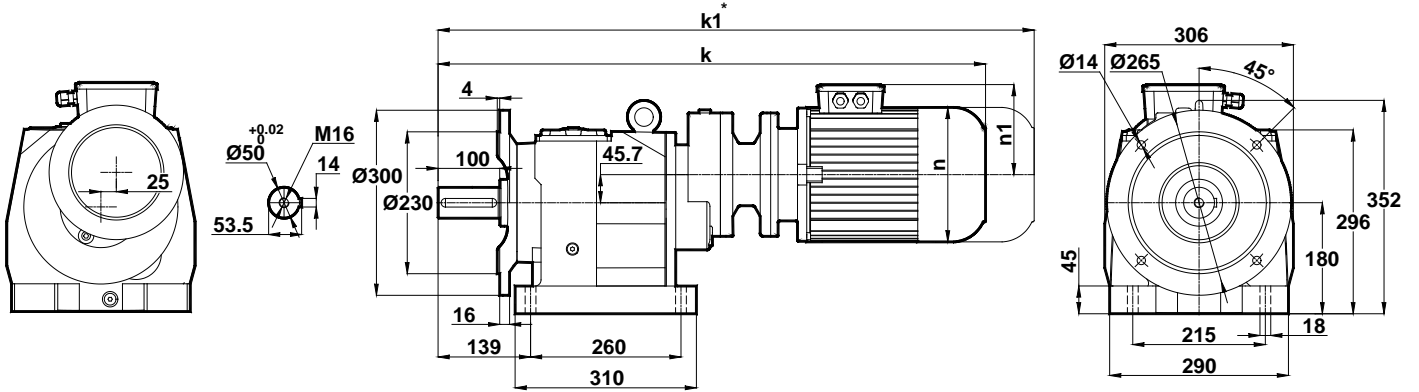

Motor Büyüklüğü / Motor Size / Motorbaugroße		
IEC	71/B5	80/B5 80/B14
k	744	764
k1	864	884
n / n1	138 / 111	156 / 118
m1 (B5)	160	200
m1 (B14)	-	120

Klemens Kutusu / Terminal Box / Klemmenkasten

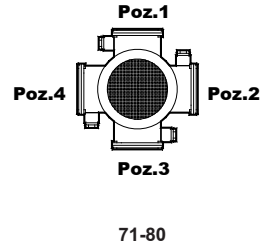

Opsiyonel Flanş Ölçüleri / Optional Flange Dimensions / Auswählbare Flanschabmessungen

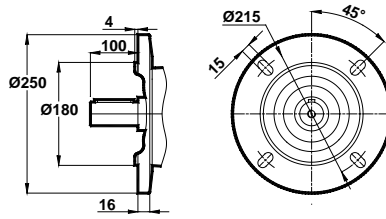

Opt. 1

* "k1" ölçüsü frenli redüktörlere aittir. 63, 71 tip elektrik motorlu redüktörler soğutmasız, diğerleri soğutmalıdır.

Dimension "k1" is for motors with brake. Gearboxes with 63 and 71 type electrical motors are not fan cooled, other types are fan cooled.
Maße "k1" ist für Bremsenmotoren. Getrieben mit 63 und 71 typ Motoren sind ohne Kühlung, andere Typen sind mit Ventilator gekühlt.



Ölçü Sayfaları Dimension Pages Abmessungsseiten



-Mil ucu çektirme deliği DIN 332 sayfa 2 / Tapped center hole to DIN 332, sheet 2 / Zentrierung mit gewinde DIN 332, Blatt 2

MVF475
MVF476

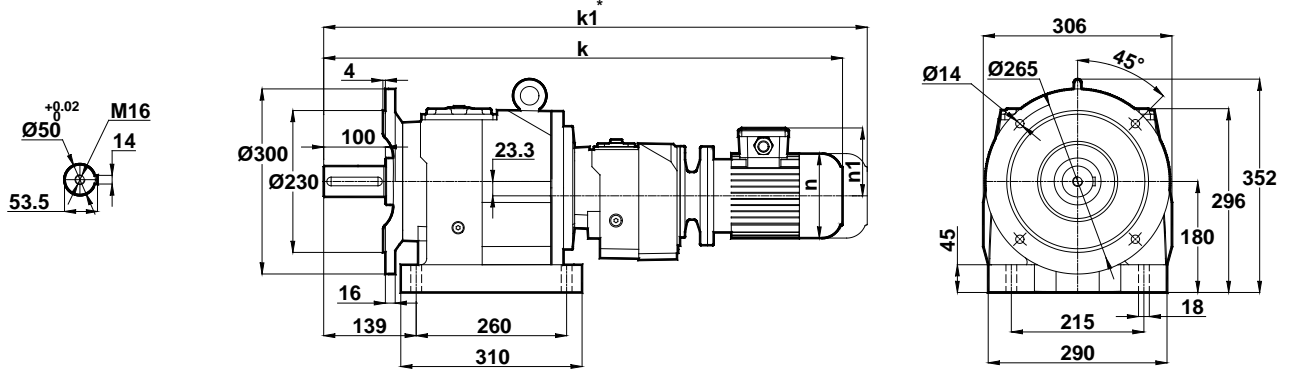

Motor Büyüklüğü / Motor Size / Motorbaugröße		
IEC	63/B5	71/B5 71/B14
k	846	843
k1	899	963
n / n1	121 / 97	138 / 111
m1 (B5)	140	160
m1 (B14)	-	105

Klemens Kutusu / Terminal Box / Klemmenkasten

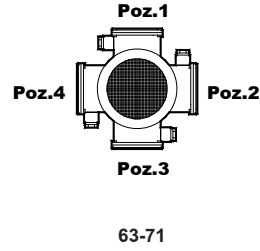

Opsiyonel Flanş Ölçüleri / Optional Flange Dimensions / Auswählbare Flanschabmessungen

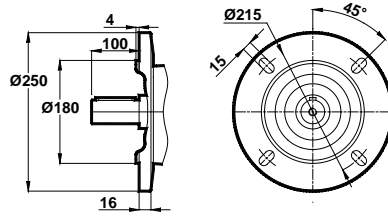

Opt. 1

* " k1 " Ölçüsü frenli redüktörlere aittir. 63, 71 tip elektrik motorlu redüktörler soğutmasız, diğerleri soğutmalıdır.
Dimension " k1 " is for motors with brake. Gearboxes with 63 and 71 type electrical motors are not fan cooled, other types are fan cooled.
Maße " k1 " ist für Bremsenmotoren. Getrieben mit 63 und 71 typ Motoren sind ohne Kühlung, andere Typen sind mit Ventilator gekühlt.

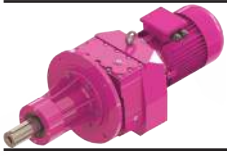

Ölçü Sayfaları Dimension Pages Abmessungenseiten



-Mil ucu çekirme deliği DIN 332 sayfa 2 / Tapped center hole to DIN 332, sheet 2 / Zentrierung mit gewinde DIN 332, Blatt 2

NRB202 NRB203

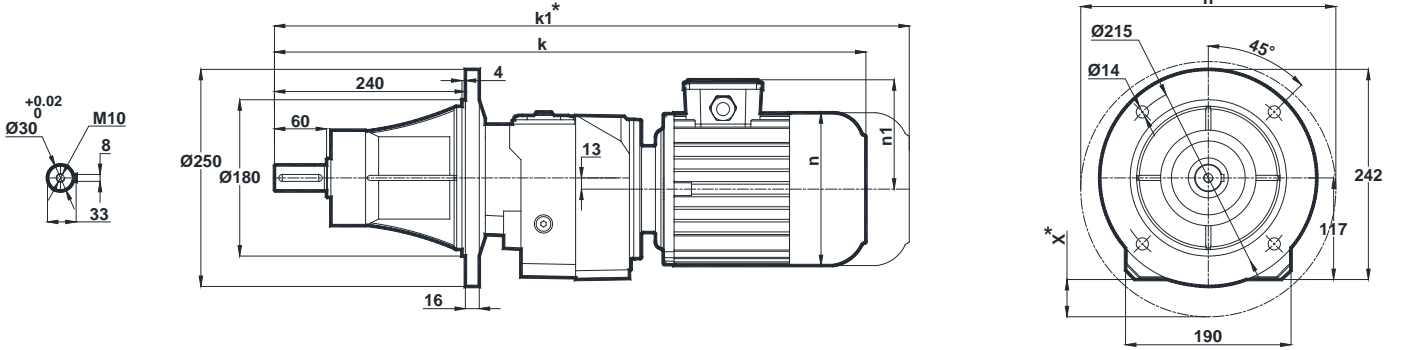

Motor Büyüklüğü / Motor Size / Motorbaugroße							
	63	71	80	90S	90L	100L	112M
k	622	640	668	696	721	762	785
k1	675	760	788	821	846	897	920
n	121	138	156	176	176	194	218
n1	97	111	118	126	126	135	146
x	-	-	-	-	-	-	10

Klemens Kutusu / Terminal Box / Klemmenkasten

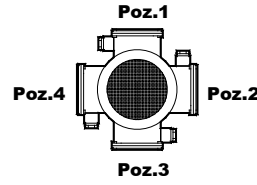

63-80-90-100-112

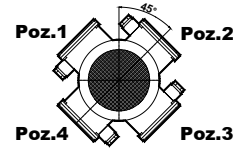

71

* " k1 " Ölçüsü frenli redüktörlere aittir. 63, 71 tip elektrik motorlu redüktörler soğutmasız, diğerleri soğutmalıdır.
Dimension " k1 " is for motors with brake. Gearboxes with 63 and 71 type electrical motors are not fan cooled, other types are fan cooled.
Maße " k1 " ist für Bremsenmotoren. Getrieben mit 63 und 71 typ Motoren sind ohne Kühlung, andere Typen sind mit Ventilator gekühlt.
x: Motor, ayak bağlantı yüzeyinin altında ise / x: If Motor is lower then foot mounting plane / x: Wenn motor ist niedriger den die Anschlußplatte

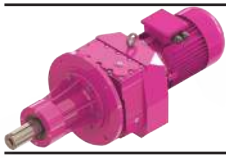

Ölçü Sayfaları Dimension Pages Abmessungsseiten



-Mil ucu çektirme deliği DIN 332 sayfa 2 / Tapped center hole to DIN 332, sheet 2 / Zentrierung mit gewinde DIN 332, Blatt 2

NRB272 NRB273

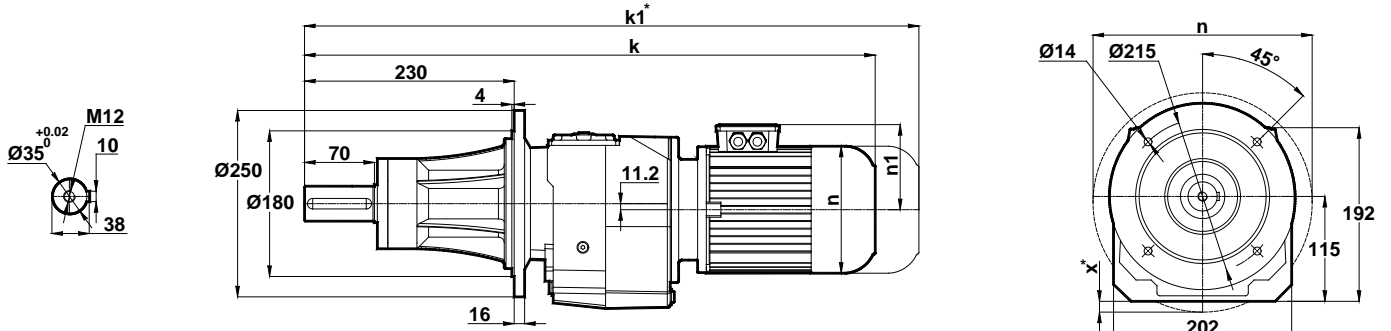

Motor Büyüklüğü / Motor Size / Motorbaugroße							
	63	71	80	90S	90L	100L	112M
k	603	622	650	678	703	744	767
k1	656	742	770	803	828	879	902
n	121	138	156	176	176	194	218
n1	97	111	118	126	126	135	146
x	-	-	-	-	-	-	9

Klemens Kutusu / Terminal Box / Klemmenkasten

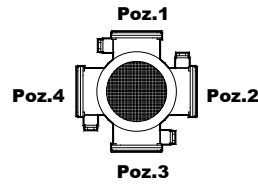

63-80-90-100-112

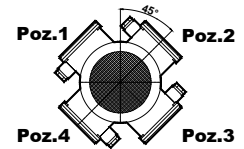

71

NRB275 NRB276

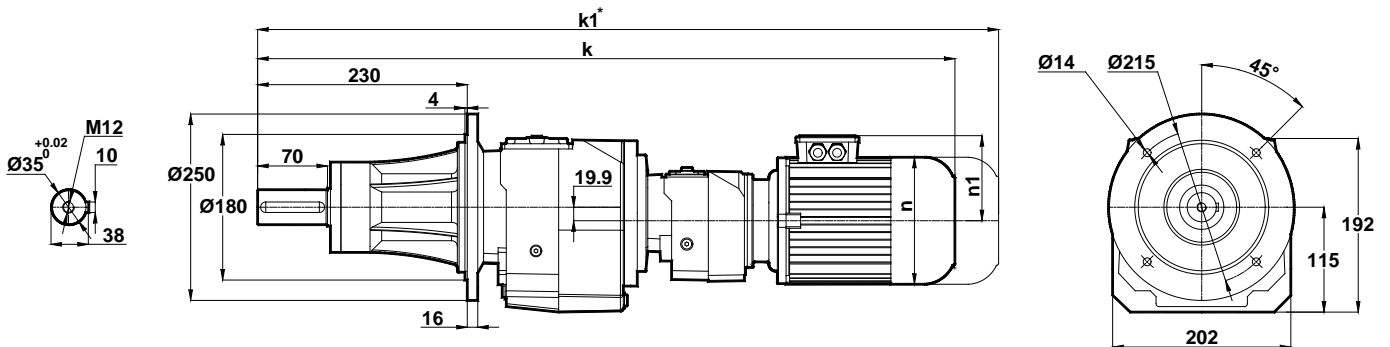

Motor Büyüklüğü / Motor Size / Motorbaugroße		
	63	71
k	753	774
k1	806	894
n	121	138
n1	97	111

Klemens Kutusu / Terminal Box / Klemmenkasten

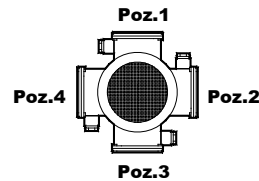

63-71

* "k1" Ölçüsü frenli redüktörlere aittir. 63, 71 tip elektrik motorlu redüktörler soğutmasız, diğerleri soğutmalıdır.

Dimension "k1" is for motors with brake. Gearboxes with 63 and 71 type electrical motors are not fan cooled, other types are fan cooled.

Maße "k1" ist für Bremsenmotoren. Getrieben mit 63 und 71 typ Motoren sind ohne Kühlung, andere Typen sind mit Ventilator gekühlt.

x: Motor Ayak bağlantı yüzeyinin altında ise / x: If Motor is lower than foot mounting plane / x: Wenn motor ist niedriger den die Anschlussplatte

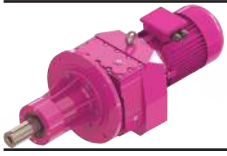

Ölçü Sayfaları Dimension Pages Abmessungsseiten



-Mil ucu çekirme deliği DIN 332 sayfa 2 / Tapped center hole to DIN 332, sheet 2 / Zentrierung mit gewinde DIN 332, Blatt 2

NRB282 NRB283

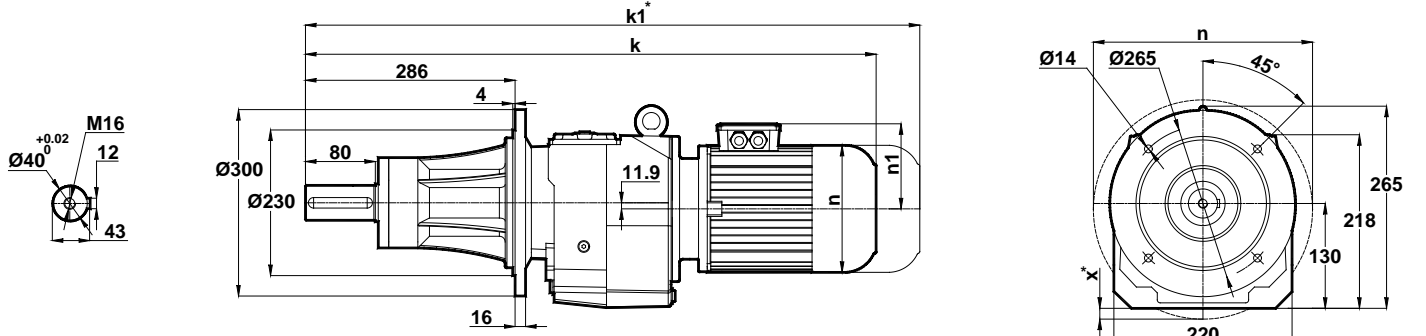

Motor Büyüklüğü / Motor Size / Motorbaugroße								
	71	80	90S	90L	100L	112M	132S	132M
k	695	723	753	778	818	841	895	933
k1	815	843	878	903	953	976	1040	1078
n	138	156	176	176	194	218	257	257
n1	111	118	126	126	135	146	168	168
x	-	-	-	-	-	-	-	14

Klemens Kutusu / Terminal Box / Klemmenkasten

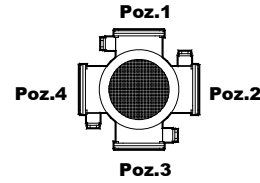

71-100-112-132

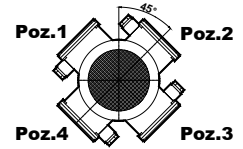

80-90

NRB284

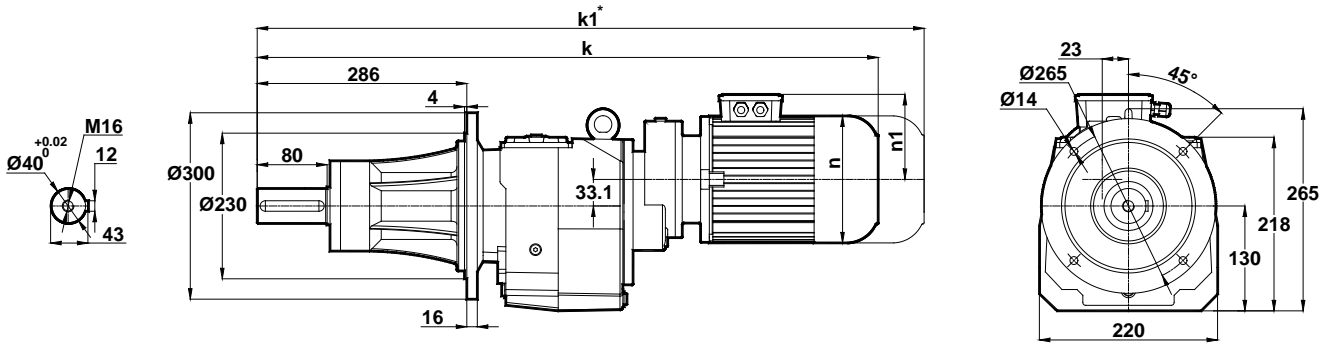

Motor Büyüklüğü / Motor Size / Motorbaugroße		
	63	71
k	756	774
k1	809	894
n	121	138
n1	97	111

Klemens Kutusu / Terminal Box / Klemmenkasten

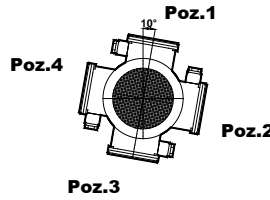

63

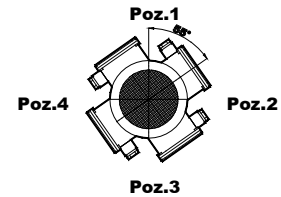

71

* " k1 " Ölçüsü frenli redüktörlere aittir. 63, 71 tip elektrik motorlu redüktörler soğutmasız, diğerleri soğutmalıdır.

Dimension " k1 " is for motors with brake. Gearboxes with 63 and 71 type electrical motors are not fan cooled, other types are fan cooled.

Maße " k1 " ist für Bremsenmotoren. Getrieben mit 63 und 71 typ Motoren sind ohne Kühlung, andere Typen sind mit Ventilator gekühlt.

x: Motor, ayak bağlantı yüzeyinin altında ise / x: If Motor is lower then foot mounting plane / x: Wenn motor ist niedriger den die Anschlußplatte

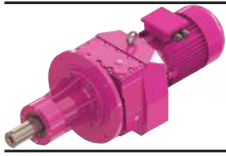

Ölçü Sayfaları Dimension Pages Abmessungsseiten



-Mil ucu çektirme deliği DIN 332 sayfa 2 / Tapped center hole to DIN 332, sheet 2 / Zentrierung mit gewinde DIN 332, Blatt 2

NRB285
NRB286

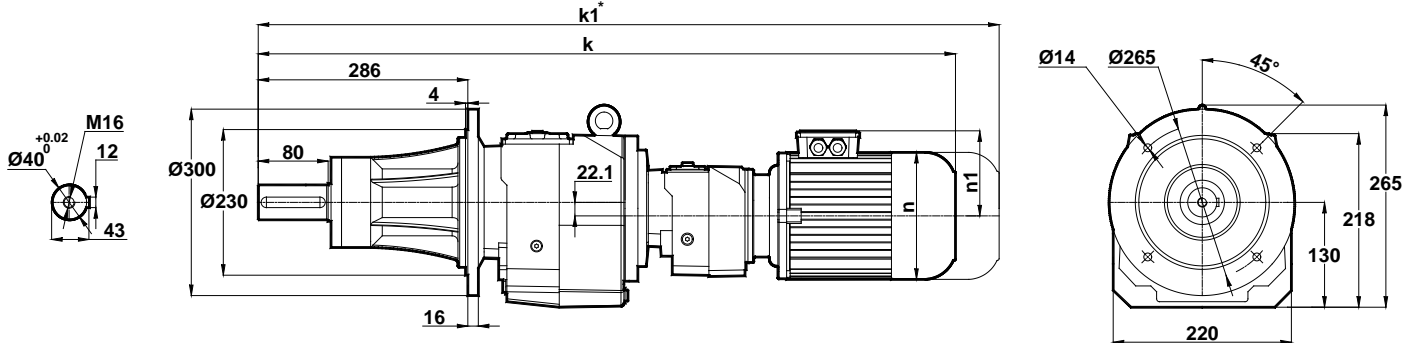

Motor Büyüklüğü / Motor Size / Motorbaugroße	
	63
k	857
k1	910
n	121
n1	97

Klemens Kutusu / Terminal Box / Klemmenkasten

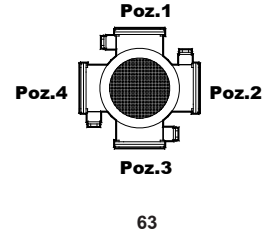

63

* "k1" Ölçüsü frenli redüktörlere aittir. 63, 71 tip elektrik motorlu redüktörler soğutmasız, diğerleri soğutmalıdır.
Dimension "k1" is for motors with brake. Gearboxes with 63 and 71 type electrical motors are not fan cooled, other types are fan cooled.
Maße "k1" ist für Bremsenmotoren. Getrieben mit 63 und 71 typ Motoren sind ohne Kühlung, andere Typen sind mit Ventilator gekühlt.

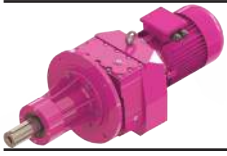

Ölçü Sayfaları Dimension Pages Abmessungsseiten



-Mil ucu çektirme deliği DIN 332 sayfa 2 / Tapped center hole to DIN 332, sheet 2 / Zentrierung mit gewinde DIN 332, Blatt 2

NRB372 NRB373

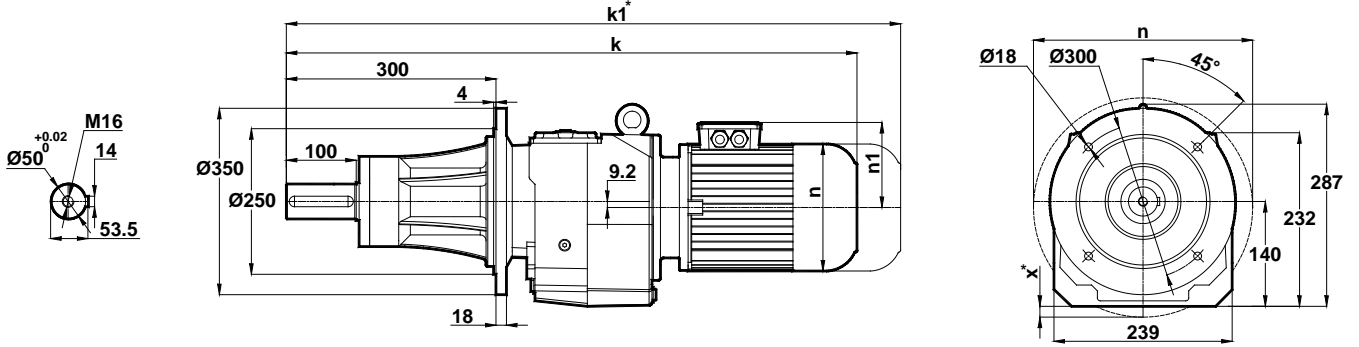

Motor Büyüklüğü / Motor Size / Motorbaugroße								
	71	80	90S	90L	100L	112M	132S	132M
k	720	748	778	803	843	866	920	958
k1	840	868	903	928	978	1001	1065	1103
n	138	156	176	176	194	218	257	257
n1	111	118	126	126	135	146	168	168
x	-	-	-	-	-	-	2	30

Klemens Kutusu / Terminal Box / Klemmenkasten

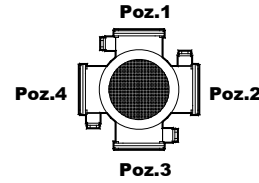

71-100-112-132

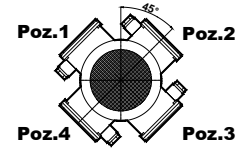

80-90

NRB374

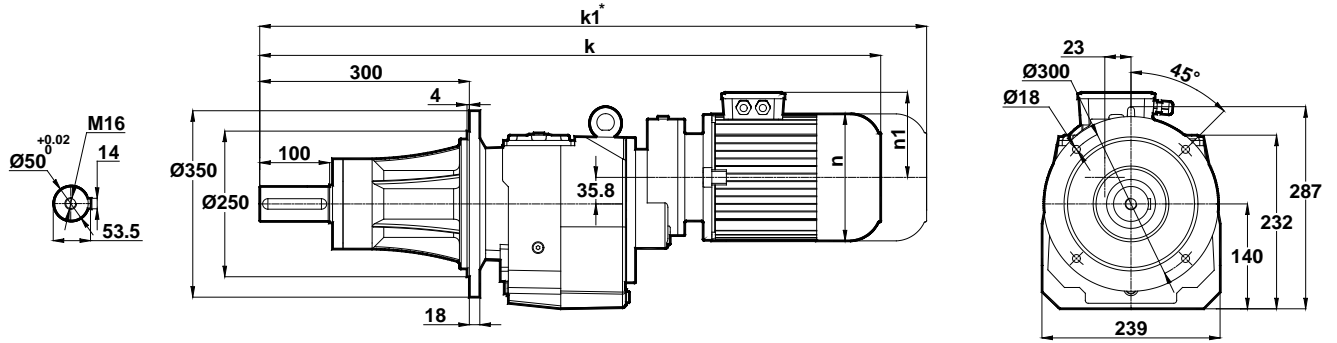

Motor Büyüklüğü / Motor Size / Motorbaugroße			
	63	71	80
k	781	799	828
k1	834	919	948
n	121	138	156
n1	97	111	118

Klemens Kutusu / Terminal Box / Klemmenkasten

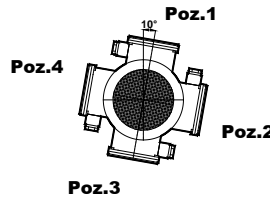

63-80

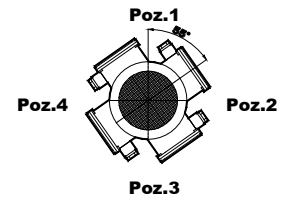

71

* "k1" Ölçüsü frenli redüktörlere aittir. 63, 71 tip elektrik motorlu redüktörler soğutmasız, diğerleri soğutmalıdır.

Dimension "k1" is for motors with brake. Gearboxes with 63 and 71 type electrical motors are not fan cooled, other types are fan cooled.

Maße "k1" ist für Bremsenmotoren. Getrieben mit 63 und 71 typ Motoren sind ohne Kühlung, andere Typen sind mit Ventilator gekühlt.

x: Motor, ayak bağlantı yüzeyinin altında ise / x: If Motor is lower then foot mounting plane / x: Wenn motor ist niedriger den die Anschlußplatte

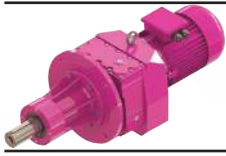

Ölçü Sayfaları Dimension Pages Abmessungsseiten



-Mil ucu çekirtme deliği DIN 332 sayfa 2 / Tapped center hole to DIN 332, sheet 2 / Zentrierung mit gewinde DIN 332, Blatt 2

NRB375
NRB376

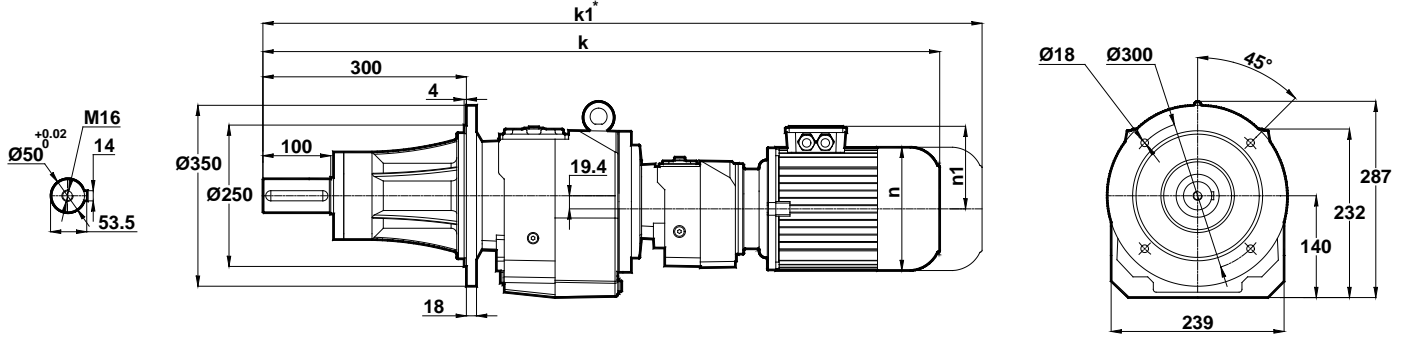

Motor Büyüklüğü / Motor Size / Motorbaugroße	
	63
k	882
k1	935
n	121
n1	97

Klemens Kutusu / Terminal Box / Klemmenkasten

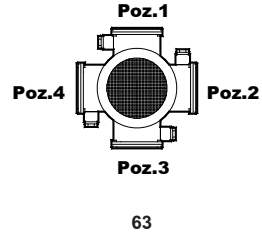

* " k1 " Ölçüsü frenli redüktörlere aittir. 63, 71 tip elektrik motorlu redüktörler soğutmasız, diğerleri soğutmalıdır.
Dimension " k1 " is for motors with brake. Gearboxes with 63 and 71 type electrical motors are not fan cooled, other types are fan cooled.
Maße " k1 " ist für Bremsenmotoren. Getrieben mit 63 und 71 typ Motoren sind ohne Kühlung, andere Typen zind mit Ventilator gekühlt.

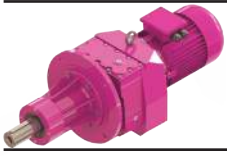

Ölçü Sayfaları Dimension Pages Abmessungsseiten



-Mil ucu çektirme deliği DIN 332 sayfa 2 / Tapped center hole to DIN 332, sheet 2 / Zentrierung mit gewinde DIN 332, Blatt 2

NRB472 NRB473

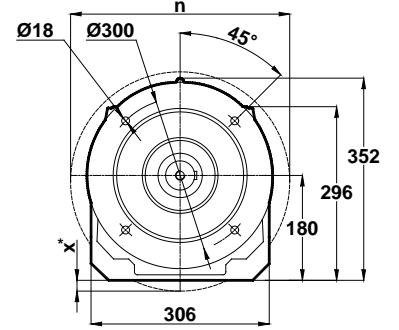
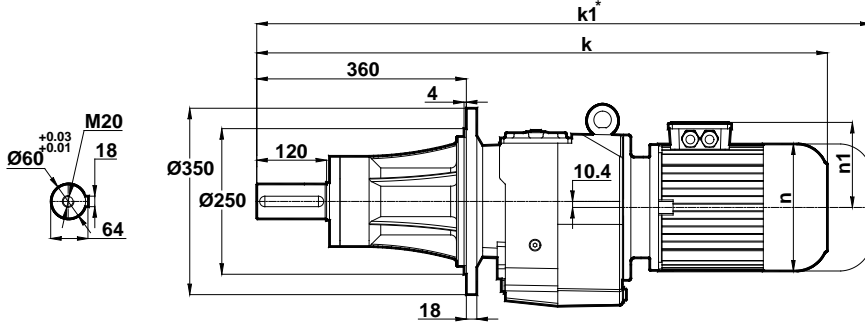

Motor Büyüklüğü / Motor Size / Motorbaugroße											
	80	90S	90L	100L	112M	132S	132M	160M	160L	180M	180L
k	856	884	909	947	973	1022	1060	1135	1179	1196	1234
k1	976	1009	1034	1082	1108	1167	1205	1305	1349	1366	1404
n	156	176	176	194	218	257	257	310	310	348	348
n1	118	126	126	135	146	168	168	225	225	241	241
x	-	-	-	-	-	-	-	-	-	11	11

Klemens Kutusu / Terminal Box / Klemmenkasten

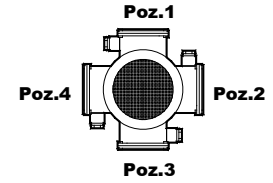

80-90-100-112-132-160-180

NRB474

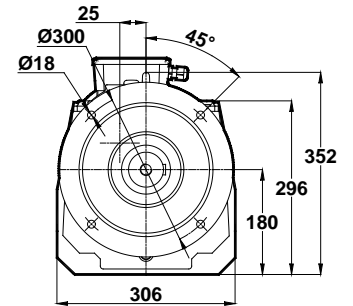
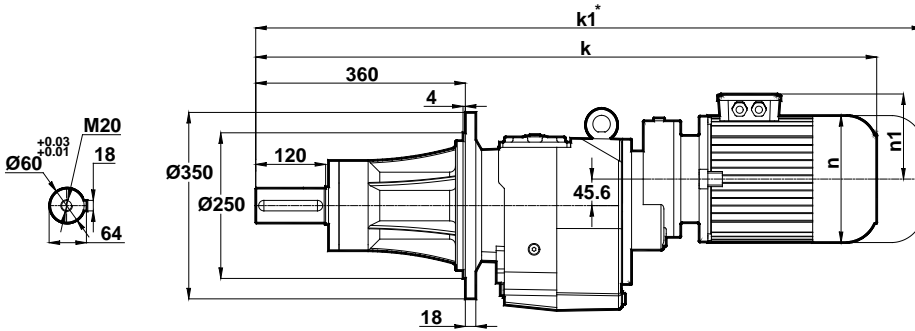

Klemens Kutusu / Terminal Box / Klemmenkasten

Motor Büyüklüğü / Motor Size / Motorbaugroße		
	71	80
k	921	949
k1	1041	1069
n	138	156
n1	111	118

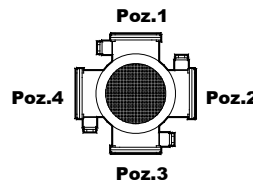

71

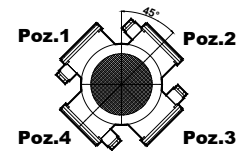

80

* "k1" Ölçüsü frenli redüktörlere aittir. 63, 71 tip elektrik motorlu redüktörler soğutmasız, diğerleri soğutmalıdır.

Dimension "k1" is for motors with brake. Gearboxes with 63 and 71 type electrical motors are not fan cooled, other types are fan cooled.

Maße "k1" ist für Bremsenmotoren. Getrieben mit 63 und 71 typ Motoren sind ohne Kühlung, andere Typen sind mit Ventilator gekühlt.

x: Motor, ayak bağlantı yüzeyinin altında ise / x: If Motor is lower then foot mounting plane / x: Wenn motor ist niedriger den die Anschlußplatte

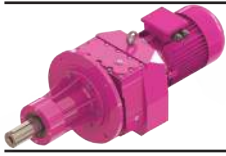

Ölçü Sayfaları Dimension Pages Abmessungenseiten



-Mil ucu çektirme deliği DIN 332 sayfa 2 / Tapped center hole to DIN 332, sheet 2 / Zentrierung mit gewinde DIN 332, Blatt 2

NRB475 NRB476

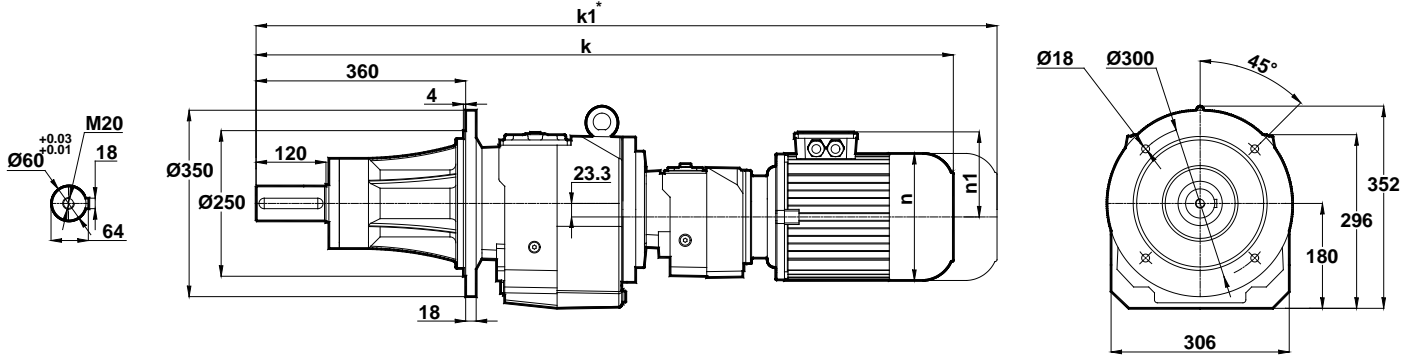

Motor Büyüklüğü / Motor Size / Motorbaugroße		
	63	71
k	1032	1051
k1	1085	1171
n	121	138
n1	97	111

Klemens Kutusu / Terminal Box / Klemmenkasten

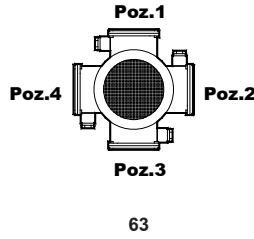

63

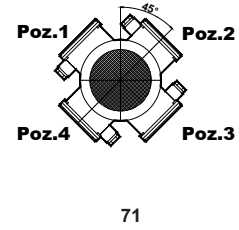

71

* "k1" Ölçüsü frenli redüktörlere aittir. 63, 71 tip elektrik motorlu redüktörler soğutmasız, diğerleri soğutmalıdır.

Dimension "k1" is for motors with brake. Gearboxes with 63 and 71 type electrical motors are not fan cooled, other types are fan cooled.

Maße "k1" ist für Bremsenmotoren. Getrieben mit 63 und 71 typ Motoren sind ohne Kühlung, andere Typen sind mit Ventilator gekühlt.

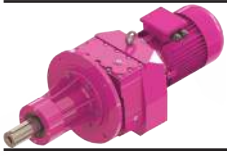

Ölçü Sayfaları Dimension Pages Abmessungsseiten



-Mil ucu çektirme deliği DIN 332 sayfa 2 / Tapped center hole to DIN 332, sheet 2 / Zentrierung mit gewinde DIN 332, Blatt 2

NRB572 NRB573

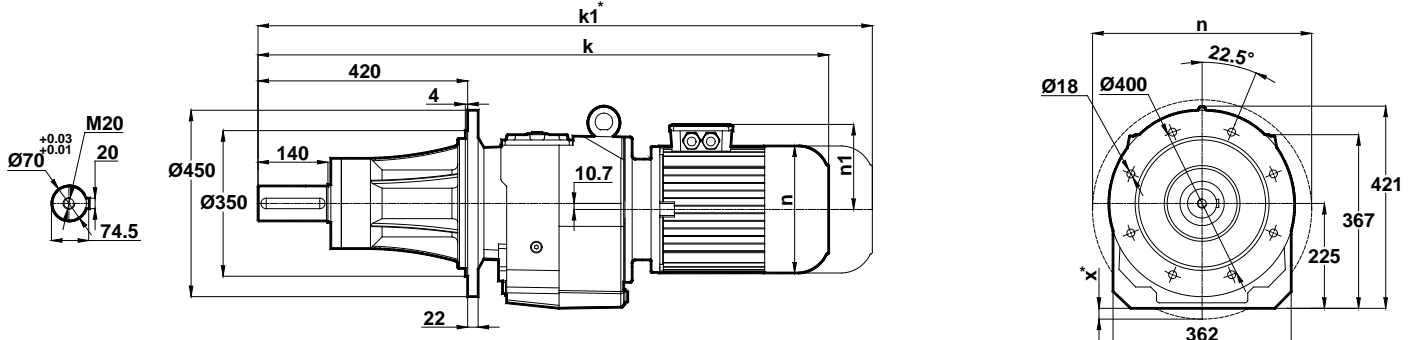

Motor Büyüklüğü / Motor Size / Motorbaugroße									
	100L	112M	132S	132M	160M	160L	180M	180L	200L
k	1065	1088	1142	1180	1255	1299	1315	1353	1392
k1	1200	1223	1287	1325	1425	1469	1485	1523	1592
n	194	218	257	257	310	310	348	348	390
n1	135	146	168	168	225	225	241	241	275
x	-	-	-	-	-	-	-	-	-

Klemens Kutusu / Terminal Box / Klemmenkasten

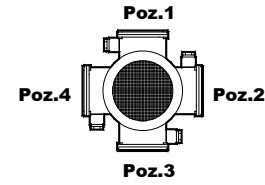

100-112-132-160-180-200

NRB574

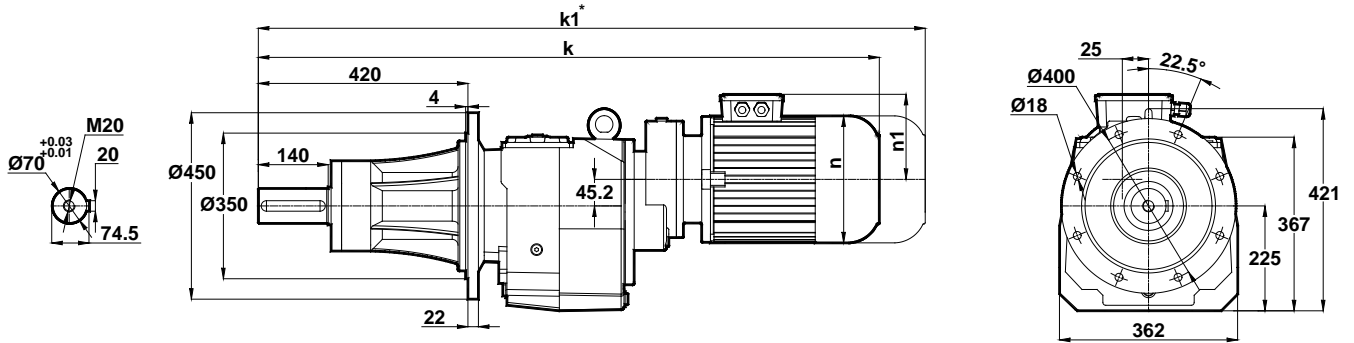

Motor Büyüklüğü / Motor Size / Motorbaugroße				
	71	80	90S	90L
k	1043	1071	1100	1125
k1	1163	1191	1225	1250
n	138	156	176	176
n1	111	118	126	126

Klemens Kutusu / Terminal Box / Klemmenkasten

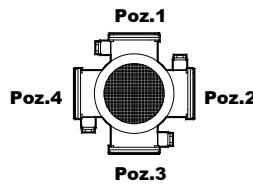

71

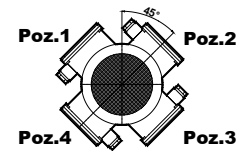

80-90

* " k1 " Ölçüsü frenli redüktörlere aittir. 63, 71 tip elektrik motorlu redüktörler soğutmasız, diğerleri soğutmalıdır.
Dimension " k1 " is for motors with brake. Gearboxes with 63 and 71 type electrical motors are not fan cooled, other types are fan cooled.
Maße " k1 " ist für Bremsenmotoren. Getrieben mit 63 und 71 typ Motoren sind ohne Kühlung, andere Typen sind mit Ventilator gekühlt.
x: Motor, ayak bağlantı yüzeyinin altında ise / x: If Motor is lower than foot mounting plane / x: Wenn motor ist niedriger den die Anschlußplatte

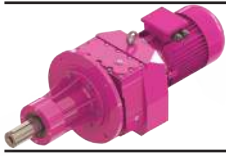

Ölçü Sayfaları Dimension Pages Abmessungsseiten



-Mil ucu çekirme deliği DIN 332 sayfa 2 / Tapped center hole to DIN 332, sheet 2 / Zentrierung mit gewinde DIN 332, Blatt 2

NRB575 NRB576

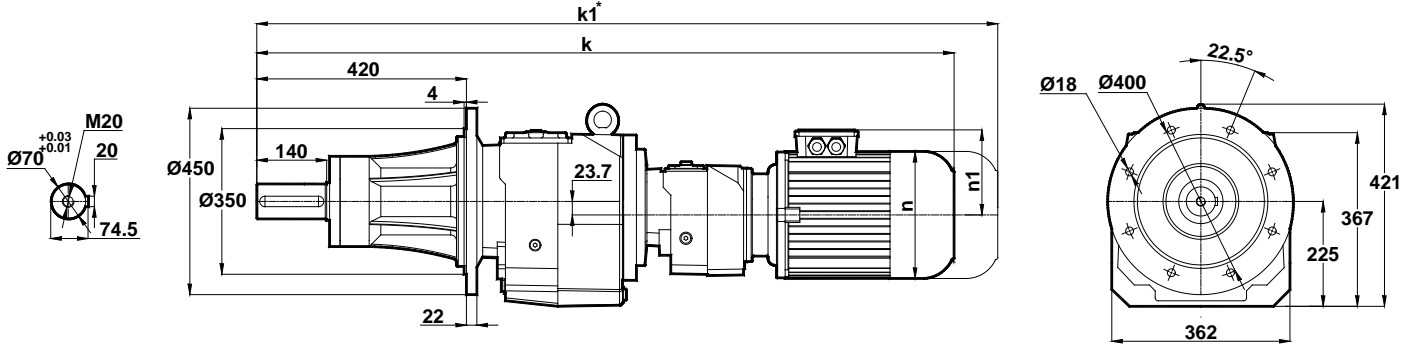

Motor Büyüklüğü / Motor Size / Motorbaugroße		
	63	71
k	1156	1175
k1	1209	1295
n	121	138
n1	97	111

Klemens Kutusu / Terminal Box / Klemmenkasten

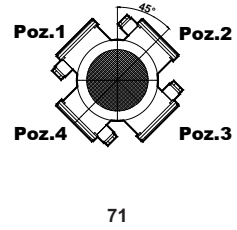
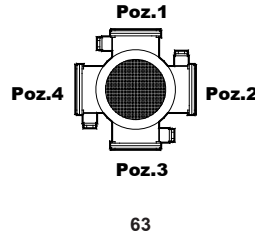

* " k1 " Ölçüsü frenli redüktörlere aittir. 63, 71 tip elektrik motorlu redüktörler soğutmasız, diğerleri soğutmalıdır.
Dimension " k1 " is for motors with brake. Gearboxes with 63 and 71 type electrical motors are not fan cooled, other types are fan cooled.
Maße " k1 " ist für Bremsenmotoren. Getrieben mit 63 und 71 typ Motoren sind ohne Kühlung, andere Typen sind mit Ventilator gekühlt.

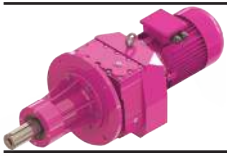

Ölçü Sayfaları Dimension Pages Abmessungsseiten



-Mil ucu çektirme deliği DIN 332 sayfa 2 / Tapped center hole to DIN 332, sheet 2 / Zentrierung mit gewinde DIN 332, Blatt 2

NRB672 NRB673

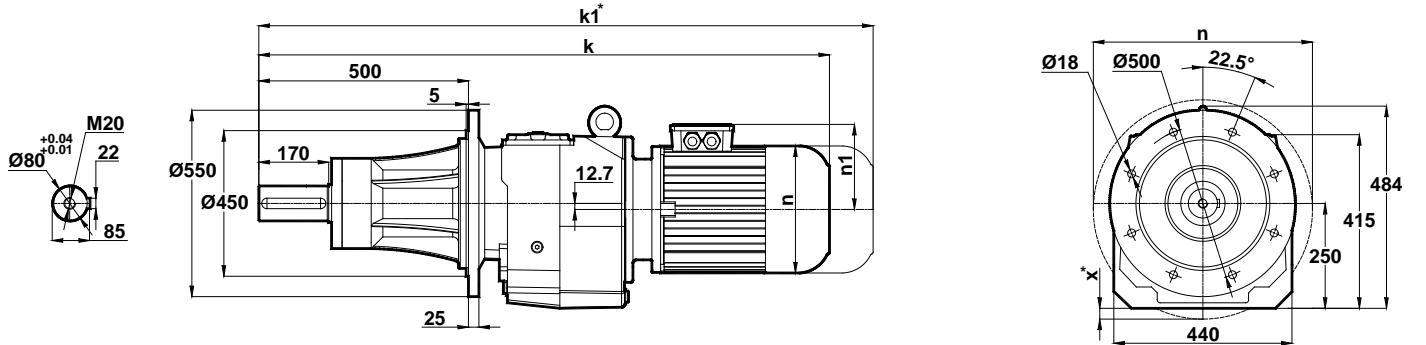

Motor Büyüklüğü / Motor Size / Motorbaugroße										
	112M	132S	132M	160M	160L	180M	180L	200L	225S	225M
k	1185	1239	1277	1351	1395	1409	1447	1489	1515	1540
k1	1320	1384	1422	1521	1565	1579	1617	1689	1705	1730
n	218	257	257	310	310	348	348	390	434	434
n1	146	168	168	225	225	241	241	275	285	285
x	-	-	-	-	-	-	-	-	-	-

Klemens Kutusu / Terminal Box / Klemmenkasten

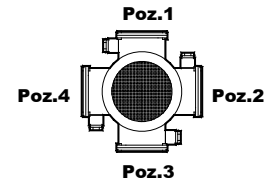

112-132-160-180-200-225

NRB674

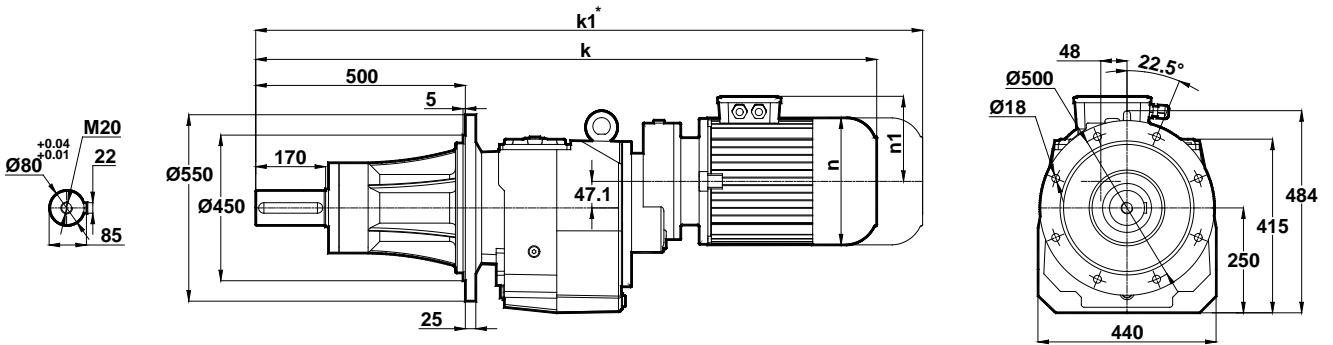

Motor Büyüklüğü / Motor Size / Motorbaugroße			
	80	90S	90L
k	1187	1215	1240
k1	1307	1340	1365
n	156	176	176
n1	118	126	126

Klemens Kutusu / Terminal Box / Klemmenkasten

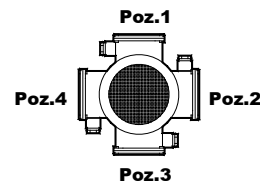

80-90

* " k1 " Ölçüsü frenli redüktörlere aittir. 63, 71 tip elektrik motorlu redüktörler soğutmasız, diğerleri soğutmalıdır.
Dimension " k1 " is for motors with brake. Gearboxes with 63 and 71 type electrical motors are not fan cooled, other types are fan cooled.
Maße " k1 " ist für Bremsenmotoren. Getrieben mit 63 und 71 typ Motoren sind ohne Kühlung, andere Typen sind mit Ventilator gekühlt.
x: Motor, ayak bağlantı yüzeyinin altında ise / x: If Motor is lower than foot mounting plane / x: Wenn motor ist niedriger den die Anschlußplatte

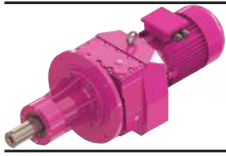

Ölçü Sayfaları Dimension Pages Abmessungsseiten



-Mil ucu çekirme deliği DIN 332 sayfa 2 / Tapped center hole to DIN 332, sheet 2 / Zentrierung mit gewinde DIN 332, Blatt 2

NRB675 NRB676

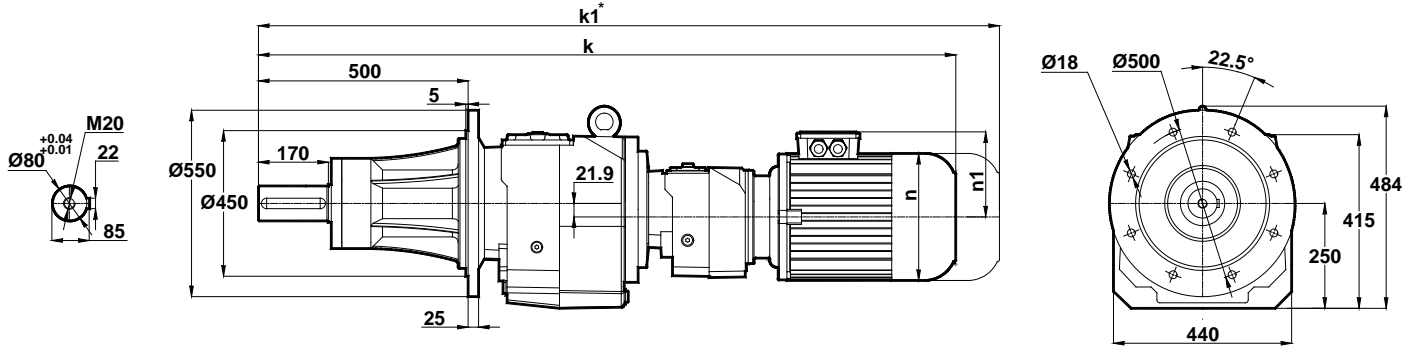

Motor Büyüklüğü / Motor Size / Motorbaugroße		
	71	80
k	1304	1332
k1	1424	1452
n	138	156
n1	111	118

Klemens Kutusu / Terminal Box / Klemmenkasten

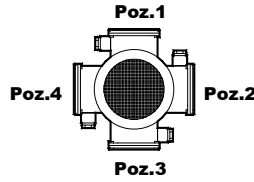

71

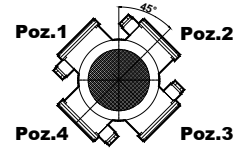

80

* "k1" Ölçüsü frenli redüktörlere aittir. 63, 71 tip elektrik motorlu redüktörler soğutmasız, diğerleri soğutmalıdır.
Dimension "k1" is for motors with brake. Gearboxes with 63 and 71 type electrical motors are not fan cooled, other types are fan cooled.
Maße "k1" ist für Bremsenmotoren. Getrieben mit 63 und 71 typ Motoren sind ohne Kühlung, andere Typen sind mit Ventilator gekühlt.

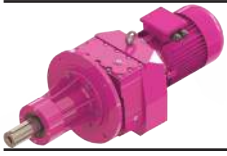

Ölçü Sayfaları Dimension Pages Abmessungsseiten



-Mil ucu çektirme deliği DIN 332 sayfa 2 / Tapped center hole to DIN 332, sheet 2 / Zentrierung mit gewinde DIN 332, Blatt 2

NRB772 NRB773

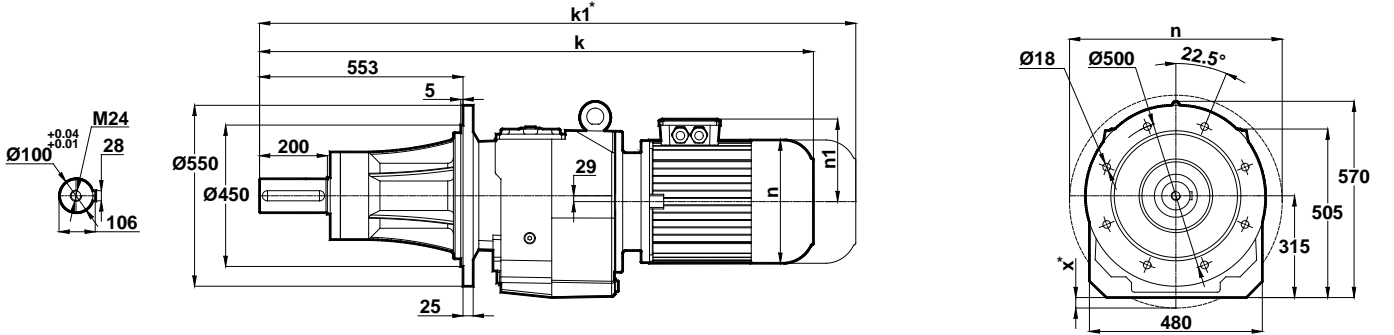

Motor Büyüklüğü / Motor Size / Motorbaugroße										
	132S	132M	160M	160L	180M	180L	200L	225S	225M	250M
k	1341	1379	1455	1499	1516	1554	1593	1620	1645	1749
k1	1486	1524	1625	1669	1686	1724	1793	1810	1835	-
n	257	257	310	310	348	348	390	434	434	480
n1	168	168	225	225	241	241	275	285	285	322
x	-	-	-	-	-	-	-	-	-	-

Klemens Kutusu / Terminal Box / Klemmenkasten

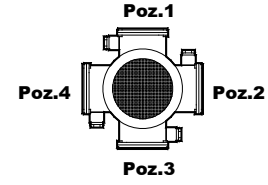

132-160-180-200-225-250

NRB774

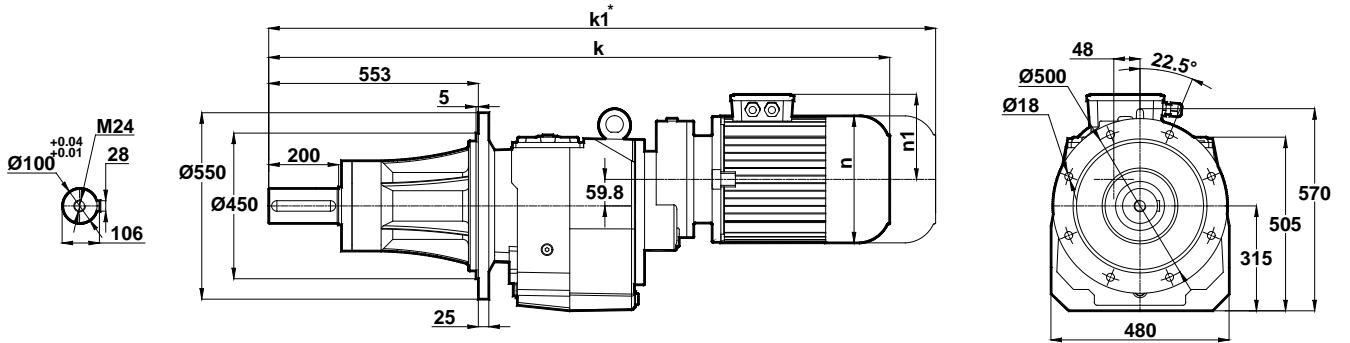

Motor Büyüklüğü / Motor Size / Motorbaugroße				
	80	90S	90L	100L
k	1295	1323	1348	1386
k1	1415	1448	1473	1521
n	156	176	176	194
n1	118	126	126	135

Klemens Kutusu / Terminal Box / Klemmenkasten

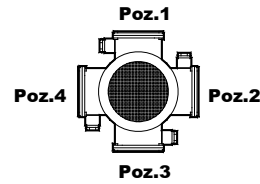

80-90-100

* " k1 " Ölçüsü frenli redüktörlere aittir. 63, 71 tip elektrik motorlu redüktörler soğutmasız, diğerleri soğutmalıdır.
Dimension " k1 " is for motors with brake. Gearboxes with 63 and 71 type electrical motors are not fan cooled, other types are fan cooled.
Maße " k1 " ist für Bremsenmotoren. Getrieben mit 63 und 71 typ Motoren sind ohne Kühlung, andere Typen sind mit Ventilator gekühlt.
x: Motor, ayak bağlantı yüzeyinin altında ise / x: If Motor is lower then foot mounting plane / x: Wenn motor ist niedriger den die Anschlußplatte

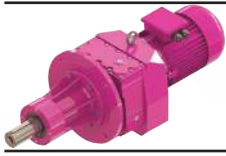

Ölçü Sayfaları Dimension Pages Abmessungsseiten



-Mil ucu çektirme deliği DIN 332 sayfa 2 / Tapped center hole to DIN 332, sheet 2 / Zentrierung mit gewinde DIN 332, Blatt 2

NRB775 NRB776

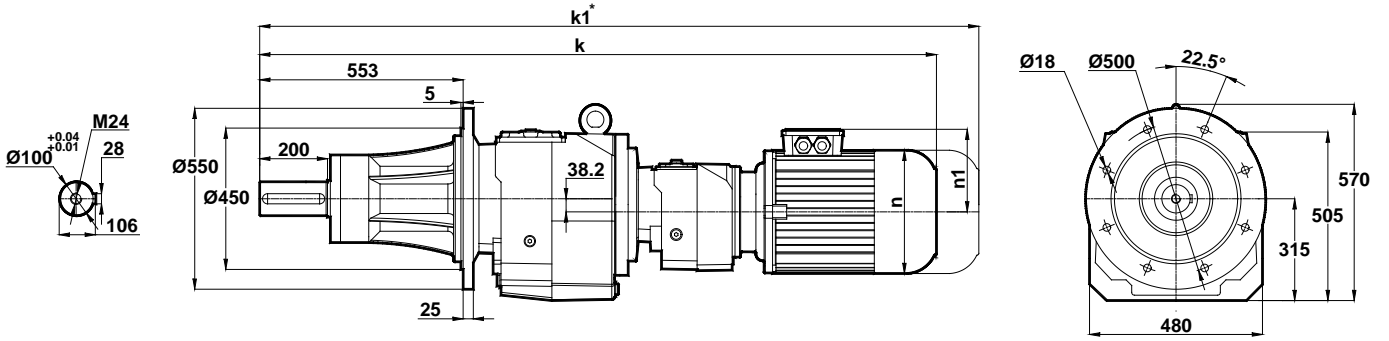

Motor Büyüklüğü / Motor Size / Motorbaugroße				
	71	80	90S	90L
k	1415	1443	1473	1498
k1	1535	1563	1598	1623
n	138	156	176	176
n1	111	118	126	126

Klemens Kutusu / Terminal Box / Klemmenkasten

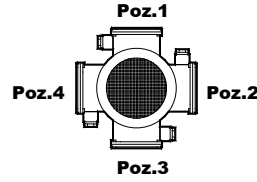

71

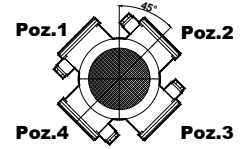

80-90

* " k1 " Ölçüsü frenli redüktörlere aittir. 63, 71 tip elektrik motorlu redüktörler soğutmasız, diğerleri soğutmalıdır.

Dimension " k1 " is for motors with brake. Gearboxes with 63 and 71 type electrical motors are not fan cooled, other types are fan cooled.

Maße " k1 " ist für Bremsenmotoren. Getrieben mit 63 und 71 typ Motoren sind ohne Kühlung, andere Typen sind mit Ventilator gekühlt.

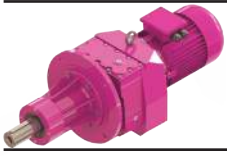

Ölçü Sayfaları Dimension Pages Abmessungsseiten



-Mil ucu çektirme deliği DIN 332 sayfa 2 / Tapped center hole to DIN 332, sheet 2 / Zentrierung mit gewinde DIN 332, Blatt 2

NRB872 NRB873

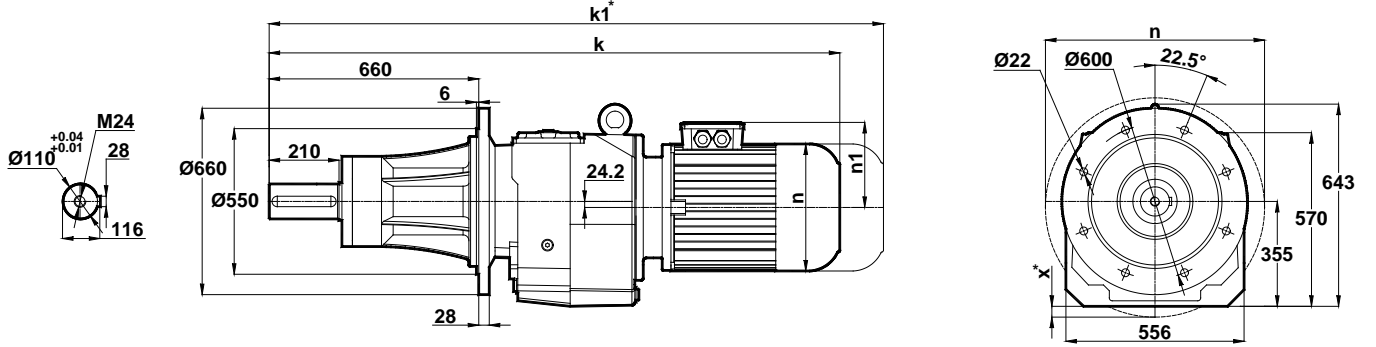

Motor Büyüklüğü / Motor Size / Motorbaugroße											
	132M	160M	160L	180M	180L	200L	225S	225M	250M	280S	280M
k	1556	1631	1675	1692	1730	1769	1798	1823	1926	1987	1987
k1	1701	1801	1845	1862	1900	1969	1988	2013	-	-	-
n	257	310	310	348	348	390	434	434	480	544	544
n1	168	225	225	241	241	275	285	285	322	350	350
x	-	-	-	-	-	-	-	-	-	-	-

Klemens Kutusu / Terminal Box / Klemmenkasten

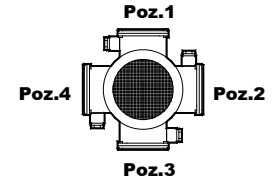

132-160-180-200-225-250-280

NRB874

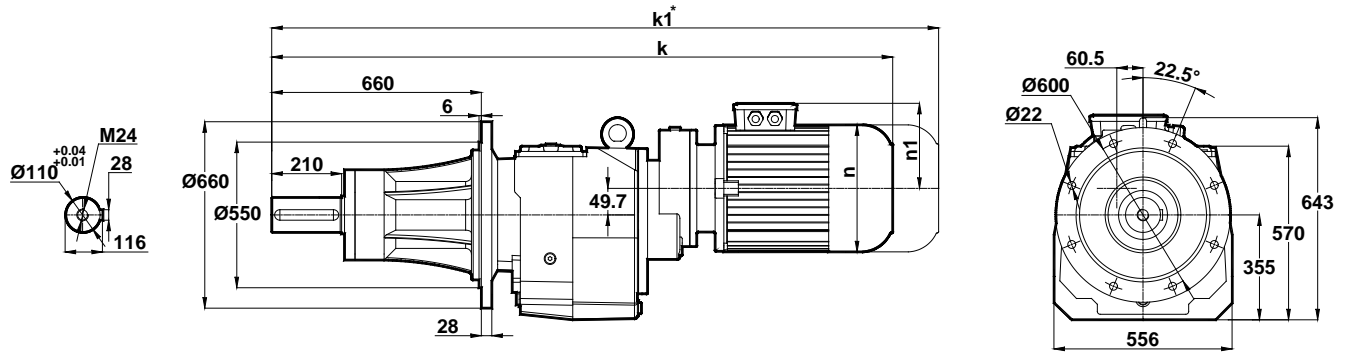

Motor Büyüklüğü / Motor Size / Motorbaugroße				
	100L	112M	132S	132M
k	1584	1607	1661	1699
k1	1719	1742	1806	1844
n	194	218	257	257
n1	135	146	168	168

Klemens Kutusu / Terminal Box / Klemmenkasten

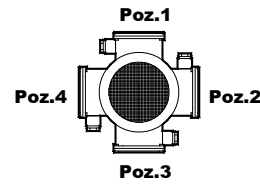

100-112-132

* " k1 " Ölçüsü frenli redüktörlere aittir. 63, 71 tip elektrik motorlu redüktörler soğutmasız, diğerleri soğutmalıdır.
Dimension " k1 " is for motors with brake. Gearboxes with 63 and 71 type electrical motors are not fan cooled, other types are fan cooled.
Maße " k1 " ist für Bremsenmotoren. Getrieben mit 63 und 71 typ Motoren sind ohne Kühlung, andere Typen sind mit Ventilator gekühlt.
x: Motor, ayak bağlantı yüzeyinin altında ise / x: If Motor is lower then foot mounting plane / x: Wenn motor ist niedriger den die Anschlußplatte

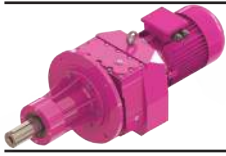

Ölçü Sayfaları Dimension Pages Abmessungsseiten



-Mil ucu çekirtme deliği DIN 332 sayfa 2 / Tapped center hole to DIN 332, sheet 2 / Zentrierung mit gewinde DIN 332, Blatt 2

NRB875 NRB876

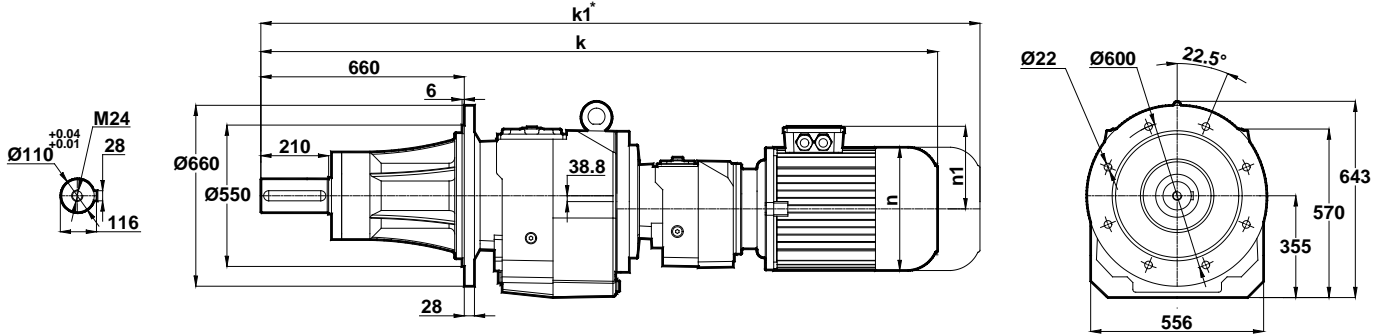

Klemens Kutusu / Terminal Box / Klemmenkasten

Motor Büyüklüğü / Motor Size / Motorbaugroße	71	80	90S	90L	100L
k	1599	1627	1657	1682	1722
k1	1719	1747	1782	1807	1857
n	138	156	176	176	194
n1	111	118	126	126	135

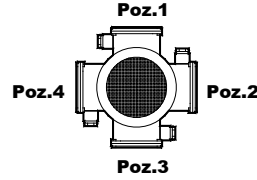

71-100

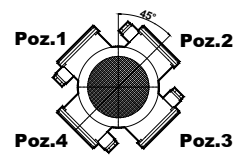

80-90

* " k1 " Ölçüsü frenli redüktörlere aittir. 63, 71 tip elektrik motorlu redüktörler soğutmasız, diğerleri soğutmalıdır.

Dimension " k1 " is for motors with brake. Gearboxes with 63 and 71 type electrical motors are not fan cooled, other types are fan cooled.

Maße " k1 " ist für Bremsenmotoren. Getrieben mit 63 und 71 typ Motoren sind ohne Kühlung, andere Typen sind mit Ventilator gekühlt.

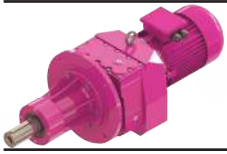

Ölçü Sayfaları Dimension Pages Abmessungsseiten



-Mil ucu çektirme deliği DIN 332 sayfa 2 / Tapped center hole to DIN 332, sheet 2 / Zentrierung mit gewinde DIN 332, Blatt 2

NRB972 NRB973

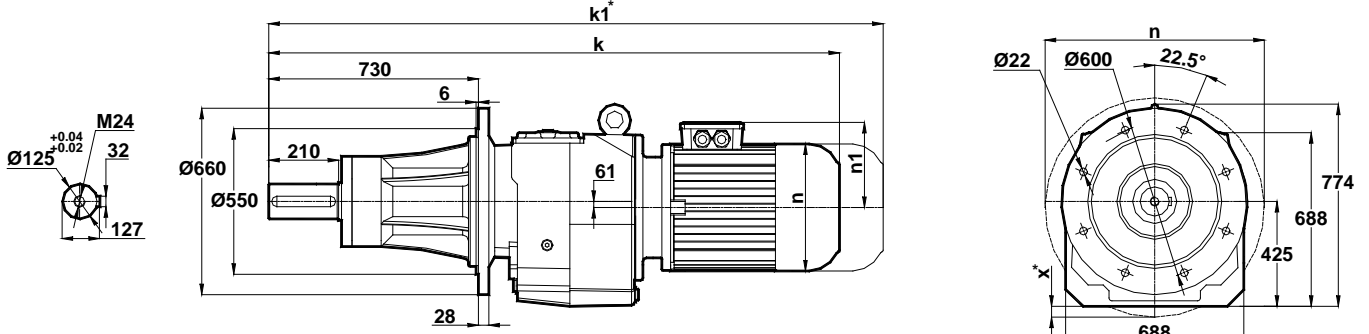

Motor Büyüklüğü / Motor Size / Motorbaugroße												
	160M	160L	180M	180L	200L	225S	225M	250M	280S	280M	315S	315M
k	1768	1812	1828	1866	1905	1923	1946	2049	2110	2110	2222	2274
k1	1938	1982	1998	2036	2105	2113	2136	-	-	-	-	-
n	310	310	348	348	390	434	434	480	544	544	614	614
n1	225	225	241	241	275	285	285	322	350	350	510	510
x	-	-	-	-	-	-	-	-	-	-	-	-

Klemens Kutusu / Terminal Box / Klemmenkasten

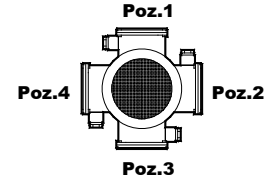

160-180-200-225-250-280-315

NRB974

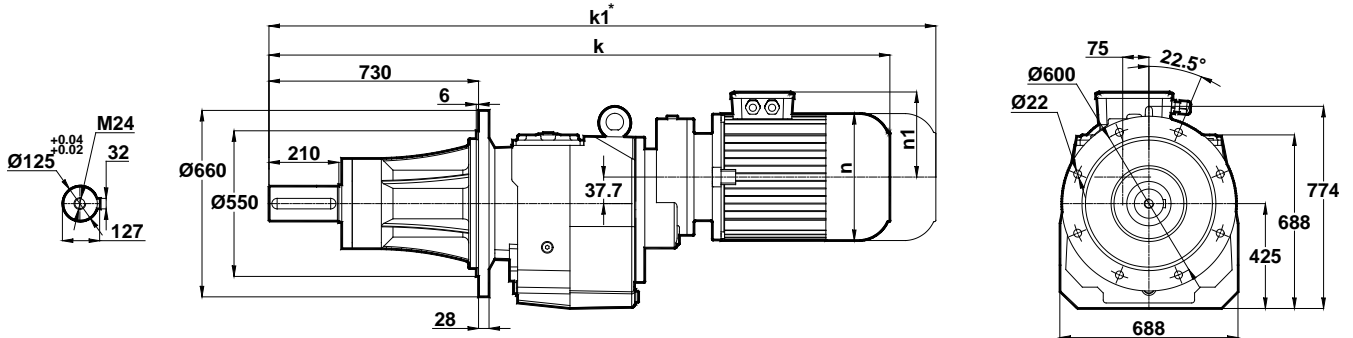

Motor Büyüklüğü / Motor Size / Motorbaugroße				
	100L	112M	132S	132M
k	1754	1777	1831	1869
k1	1889	1912	1976	2014
n	194	218	257	257
n1	135	146	168	168

Klemens Kutusu / Terminal Box / Klemmenkasten

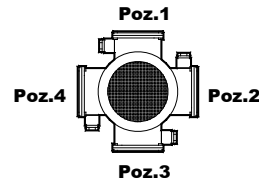

100-112-132

* " k1 " Ölçüsü frenli redüktörlere aittir. 63, 71 tip elektrik motorlu redüktörler soğutmasız, diğerleri soğutmalıdır.
Dimension " k1 " is for motors with brake. Gearboxes with 63 and 71 type electrical motors are not fan cooled, other types are fan cooled.
Maße " k1 " ist für Bremsenmotoren. Getrieben mit 63 und 71 typ Motoren sind ohne Kühlung, andere Typen sind mit Ventilator gekühlt.

x: Motor, ayak bağlantı yüzeyinin altında ise / x: If Motor is lower then foot mounting plane / x: Wenn motor ist niedriger den die Anschlußplatte

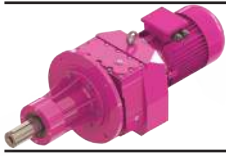

Ölçü Sayfaları Dimension Pages Abmessungsseiten



-Mil ucu çektirme deliği DIN 332 sayfa 2 / Tapped center hole to DIN 332, sheet 2 / Zentrierung mit gewinde DIN 332, Blatt 2

NRB975
NRB976

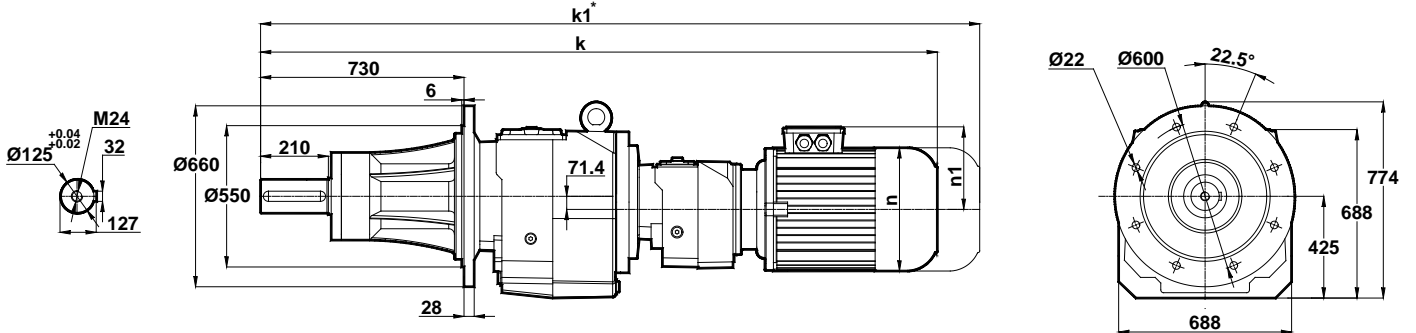

Motor Büyüklüğü / Motor Size / Motorbaugroße						
	80	90S	90L	100L	112M	132S
k	1824	1852	1877	1913	1936	1990
k1	1944	1977	2002	2048	2071	2135
n	156	176	176	194	218	257
n1	118	126	126	135	146	168

Klemens Kutusu / Terminal Box / Klemmenkasten

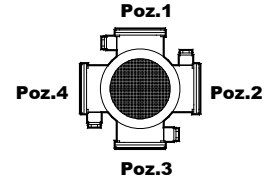

80-90-100-112-132

* "k1" Ölçüsü frenli redüktörlere aittir. 63, 71 tip elektrik motorlu redüktörler soğutmasız, diğerleri soğutmalıdır.
Dimension "k1" is for motors with brake. Gearboxes with 63 and 71 type electrical motors are not fan cooled, other types are fan cooled.
Maße "k1" ist für Bremsenmotoren. Getrieben mit 63 und 71 typ Motoren sind ohne Kühlung, andere Typen sind mit Ventilator gekühlt.

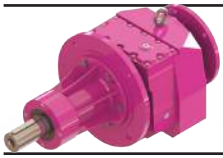

Ölçü Sayfaları Dimension Pages Abmessungsseiten



-Mil ucu çekirtme deliği DIN 332 sayfa 2 / Tapped center hole to DIN 332, sheet 2 / Zentrierung mit gewinde DIN 332, Blatt 2

NNB202-A.. NNB203-A..

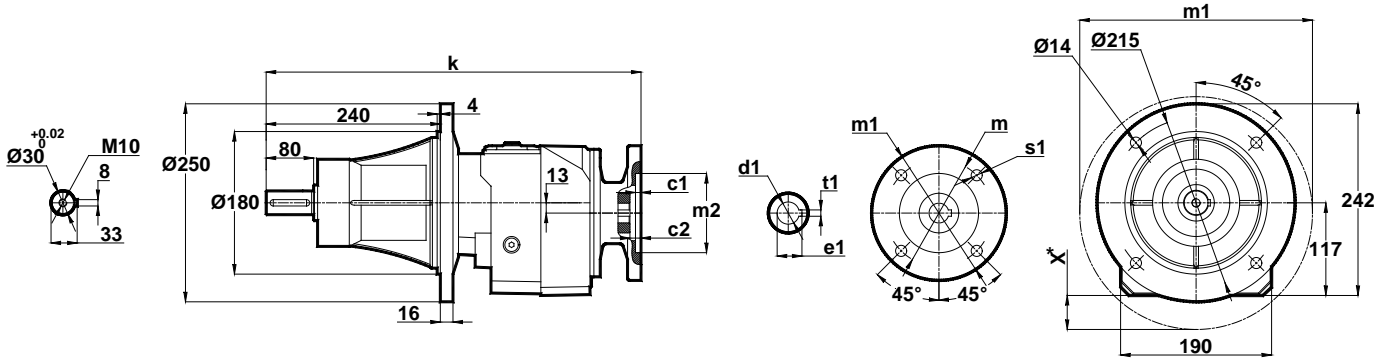

IEC	c1	c2	s1	m	m1	m2	u	k	d1	t1	e1	x
63/B5	4	5	9	115	140	95	12	503	11	4	12.8	-
71/B5	4	8.5	11	130	160	110	12	474	14	5	163	-
80/B5	4	5	12	165	200	130	12	503	19	6	21.8	-
90/B5	4	5	12	165	200	130	12	503	24	8	27.3	-
100/B5	4	5.5	15	215	250	180	12	496	28	8	31.3	23
112/B5	4	5.5	15	215	250	180	12	496	28	8	31.3	23

NNB202-B.. NNB203-B..

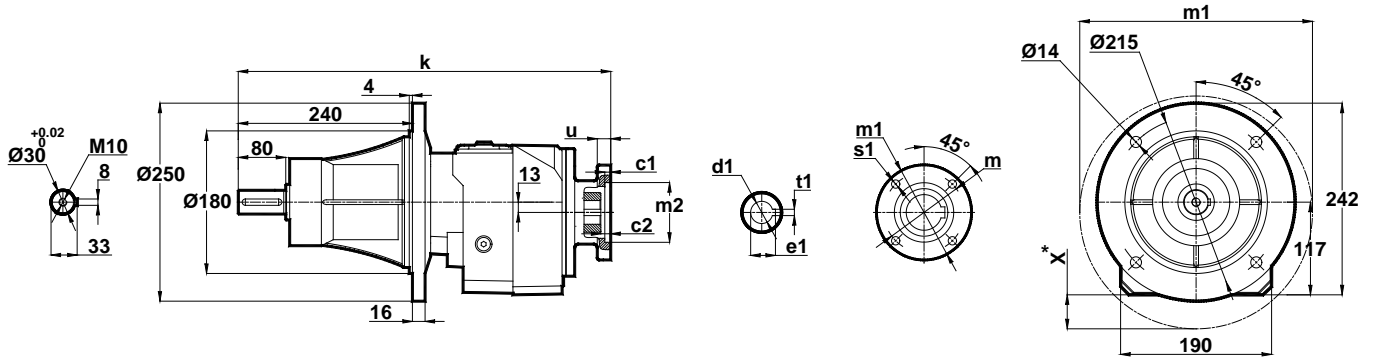

IEC	c1	c2	s1	m	m1	m2	u	k	d1	t1	e1	x
71/B14	3	8.5	7	85	105	70	10	474	14	5	16.3	-
80/B14	4	5	7	100	120	80	12	503	19	6	21.8	-
90/B14	4	5	9	115	140	95	12	503	24	8	27.3	-
100/B14	4	5.5	9	130	160	110	12	496	28	8	31.3	-
112/B14	4	5.5	9	130	160	110	12	496	28	8	31.3	-

x: Motor, ayak bağlantı yüzeyinin altında ise / x: If Motor is lower then foot mounting plane / x: Wenn motor ist niedriger den die Anschlußplatte



Ölçü Sayfaları Dimension Pages Abmessungsseiten



-Mil ucu çekirme deliği DIN 332 sayfa 2 / Tapped center hole to DIN 332, sheet 2 / Zentrierung mit gewinde DIN 332, Blatt 2

NNB272-A.. NNB273-A..

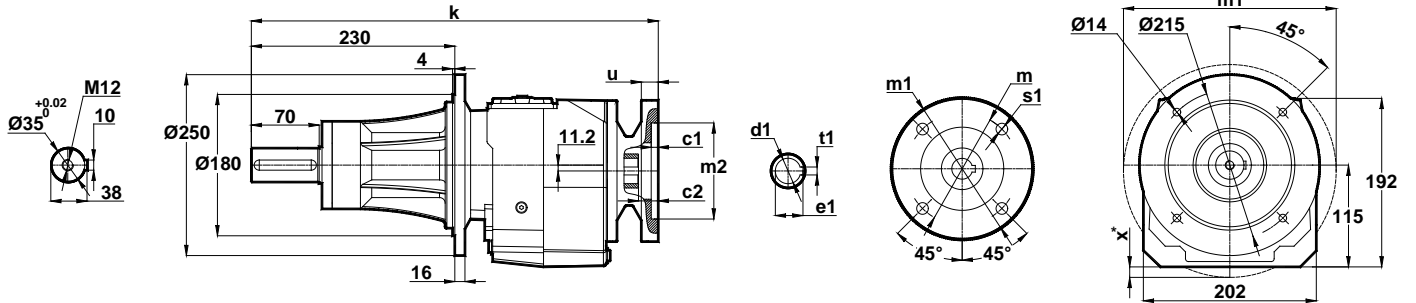

IEC	c1	c2	s1	m	m1	m2	u	k	d1	t1	e1	x
63/B5	4	5	9	115	140	95	12	484	11	4	12.8	-
71/B5	4	8.5	11	130	160	110	12	455	14	5	16.3	-
80/B5	4	5	12	165	200	130	12	484	19	6	21.8	-
90/B5	4	5	12	165	200	130	12	484	24	8	27.3	-
100/B5	4	5.5	15	215	250	180	12	477	28	8	31.3	22
112/B5	4	5.5	15	215	250	180	12	477	28	8	31.3	22

NNB272-B.. NNB273-B..

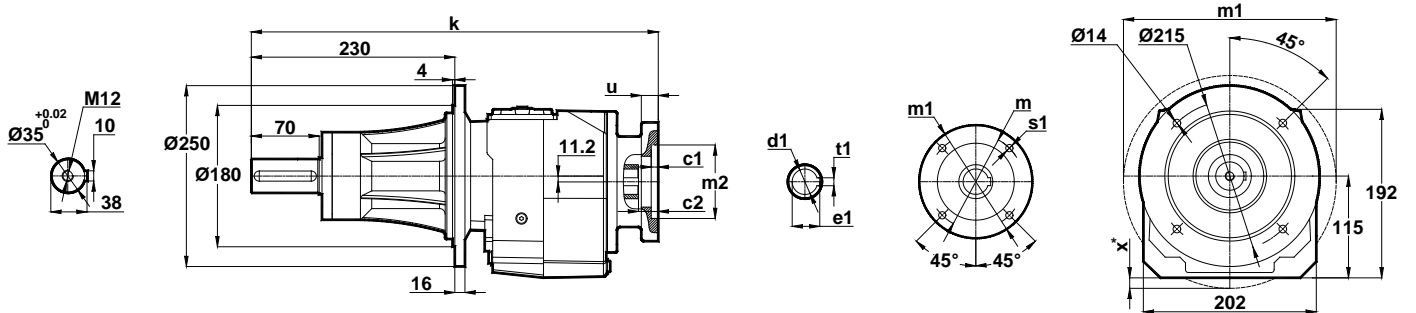

IEC	c1	c2	s1	m	m1	m2	u	k	d1	t1	e1	x
71/B14	3	8.5	7	85	105	70	10	455	14	5	16.3	-
80/B14	4	5	7	100	120	80	12	484	19	6	21.8	-
90/B14	4	5	9	115	140	95	12	484	24	8	27.3	-
100/B14	4	5.5	9	130	160	110	12	477	28	8	31.3	-
112/B14	4	5.5	9	130	160	110	12	477	28	8	31.3	-

x: Motor Ayak bağlantı yüzeyinin altında ise / x: If Motor is lower than foot mounting plane / x: Wenn motor ist niedriger den die Anschlußplatte

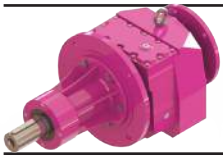

Ölçü Sayfaları

Dimension Pages

Abmessungsseiten



-Mil ucu çektirme deliği DIN 332 sayfa 2 / Tapped center hole to DIN 332, sheet 2 / Zentrierung mit gewinde DIN 332, Blatt 2

NNB275-A..

NNB276-A..

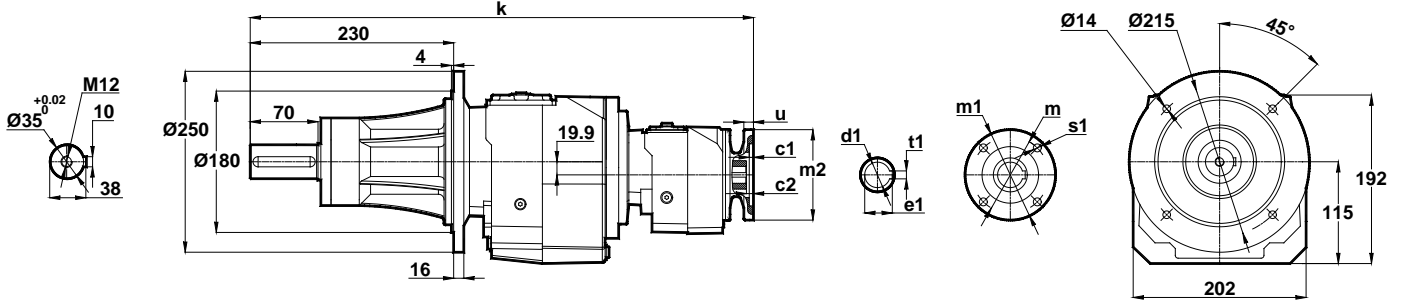

IEC	c1	c2	s1	m	m1	m2	u	k	d1	t1	e1
63/B5	3.5	5	10	115	140	95	10	599	11	4	12.8
71/B5	4	4.5	11	130	160	110	12	601	14	5	16.3

NNB275-B..

NNB276-B..

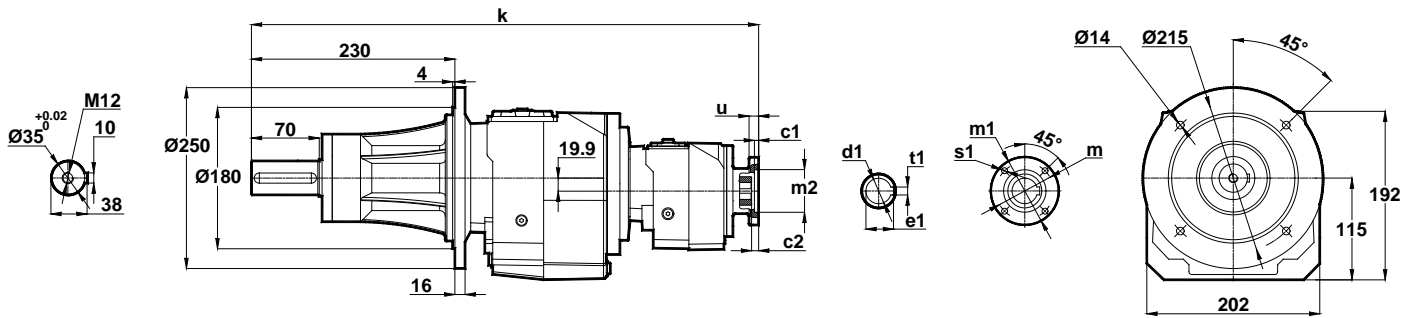

IEC	c1	c2	s1	m	m1	m2	u	k	d1	t1	e1
63/B14	2.5	5	5.5	75	90	60	10	599	11	4	12.8
71/B14	3	4.5	7	85	105	70	10	601	14	5	16.3



Ölçü Sayfaları Dimension Pages Abmessungsseiten



-Mil ucu çektirme deliği DIN 332 sayfa 2 / Tapped center hole to DIN 332, sheet 2 / Zentrierung mit gewinde DIN 332, Blatt 2

NNB282-A.. NNB283-A..

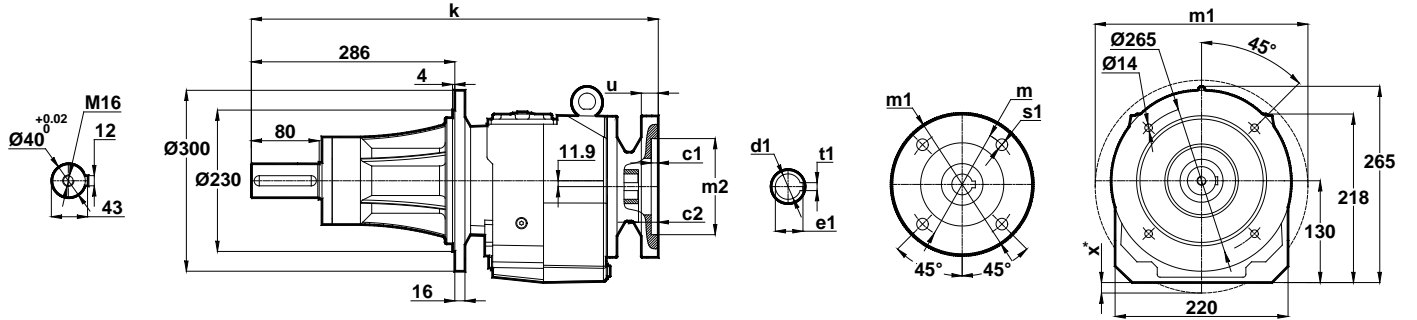

IEC	c1	c2	s1	m	m1	m2	u	k	d1	t1	e1	x
71/B5	4	9	11	130	160	110	12	559	14	5	16.3	-
80/B5	4	9	12	165	200	130	12	559	19	6	21.8	-
90/B5	4	9	12	165	200	130	12	559	24	8	27.3	-
100/B5	4.5	9	15	215	250	180	15	566	28	8	31.3	7
112/B5	4.5	9	15	215	250	180	15	566	28	8	31.3	7
132/B5	4.5	7	15	265	300	230	15	596	38	10	41.3	32

NNB282-B.. NNB283-B..

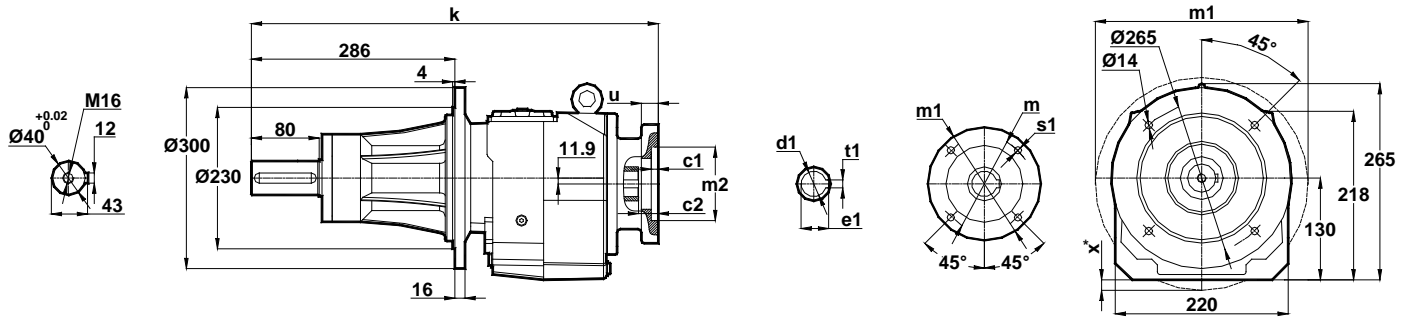

IEC	c1	c2	s1	m	m1	m2	u	k	d1	t1	e1	x
80/B14	4	9	7	100	120	80	12	559	19	6	21.8	-
90/B14	4	9	9	115	140	95	12	559	24	8	26.3	-
100/B14	4	9	9	130	160	110	15	566	28	8	31.3	-
112/B14	4	9	9	130	160	110	15	566	28	8	31.3	-
132/B14	4.5	7	11	165	200	130	15	596	38	10	41.3	-

x: Motor Ayak bağlantı yüzeyinin altında ise / x: If Motor is lower than foot mounting plane / x: Wenn motor ist niedriger den die Anschlußplatte

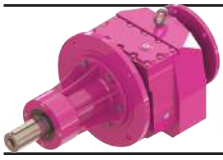

Ölçü Sayfaları

Dimension Pages

Abmessungsseiten



-Mil ucu çektirme deliği DIN 332 sayfa 2 / Tapped center hole to DIN 332, sheet 2 / Zentrierung mit gewinde DIN 332, Blatt 2

NNB284-A.. NNB284-B..

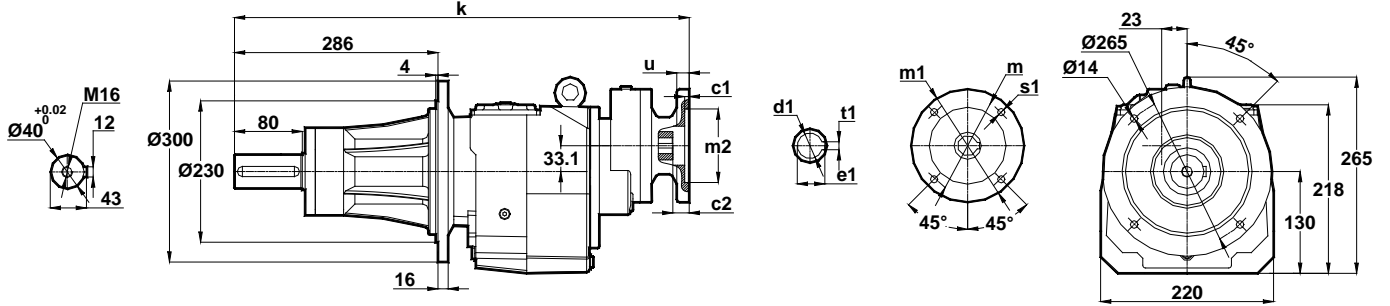

IEC	c1	c2	s1	m	m1	m2	u	k	d1	t1	e1
63/B5	3.5	5	10	115	140	95	10	636	11	4	12.8
71/B5	4	4.5	11	130	160	110	12	607	14	5	16.3
71/B14	3	4.5	7	85	105	70	10	607	14	5	16.3

NNB285-A.. / B.. NNB286-A.. / B..

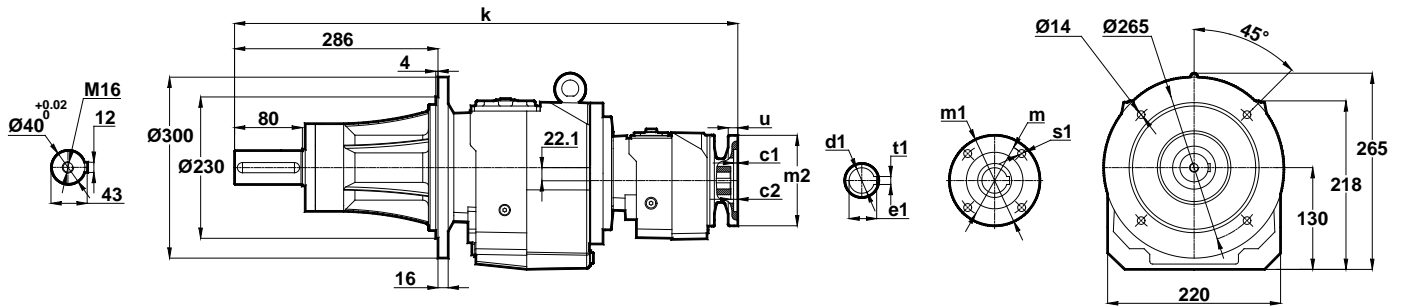

IEC	c1	c2	s1	m	m1	m2	u	k	d1	t1	e1
63/B5	4	7	10	115	140	95	12	702	11	4	12.8
63/B14	2.5	5	5.5	75	90	60	10	702	11	4	12.8



Ölçü Sayfaları Dimension Pages Abmessungsseiten



-Mil ucu çekirme deliği DIN 332 sayfa 2 / Tapped center hole to DIN 332, sheet 2 / Zentrierung mit gewinde DIN 332, Blatt 2

NNB372-A.. NNB373-A..

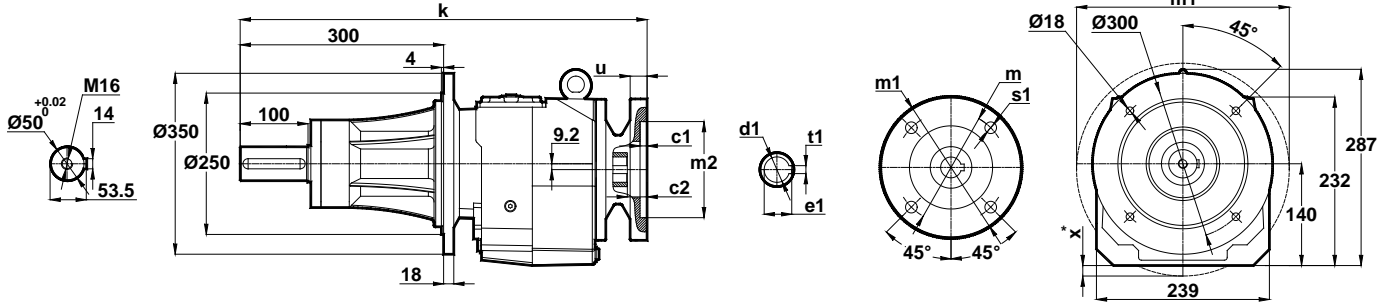

IEC	c1	c2	s1	m	m1	m2	u	k	d1	t1	e1	x
71/B5	4	9	11	130	160	110	12	584	14	5	16.3	-
80/B5	4	9	12	165	200	130	12	584	19	6	21.8	-
90/B5	4	9	12	165	200	130	12	584	24	8	27.3	-
100/B5	4.5	9	15	215	250	180	15	601	28	8	31.3	-
112/B5	4.5	9	15	215	250	180	15	601	28	8	31.3	-
132/B5	4.5	7	15	265	300	230	15	621	38	10	41.3	20

NNB372-B.. NNB373-B..

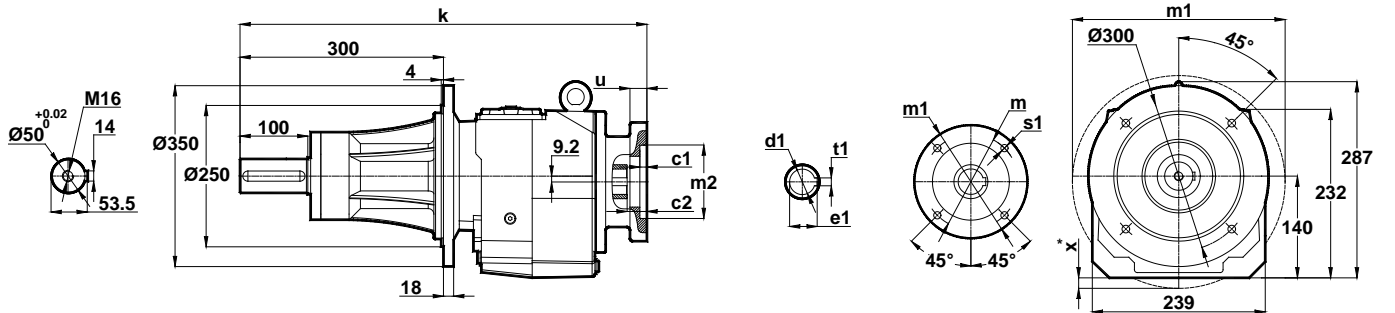

IEC	c1	c2	s1	m	m1	m2	u	k	d1	t1	e1	x
80/B14	4	9	7	100	120	80	12	584	19	6	21.8	-
90/B14	4	9	9	115	140	95	12	584	24	8	26.3	-
100/B14	4	9	9	130	160	110	15	601	28	8	31.3	-
112/B14	4	9	9	130	160	110	15	601	28	8	31.3	-
132/B14	4.5	9	11	165	200	130	15	621	38	10	41.3	-

x: Motor Ayak bağlantı yüzeyinin altında ise / x: If Motor is lower than foot mounting plane / x: Wenn motor ist niedriger den die Anschlußplatte

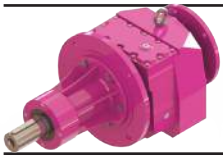

Ölçü Sayfaları

Dimension Pages

Abmessungsseiten



-Mil ucu çektirme deliği DIN 332 sayfa 2 / Tapped center hole to DIN 332, sheet 2 / Zentrierung mit gewinde DIN 332, Blatt 2

NNB374-A.. NNB374-B..

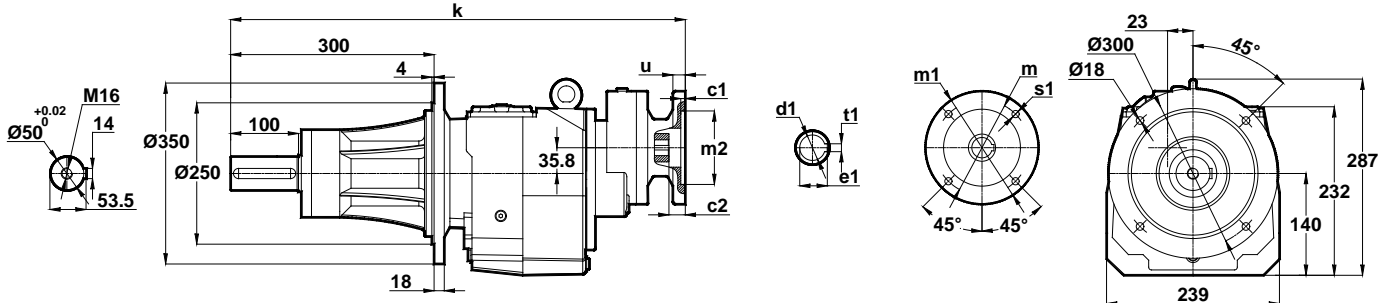

IEC	c1	c2	s1	m	m1	m2	u	k	d1	t1	e1
63/B5	4	5	9	115	140	95	12	661	11	4	12.8
71/B5	4	8.5	11	130	160	110	12	632	14	5	16.3
80/B5	4	5	12	165	200	130	12	661	19	6	21.8
71/B14	3	8.5	7	85	105	70	10	632	14	5	16.3
80/B14	4	5	7	100	120	80	12	661	19	6	21.8

NNB375-A.. / B.. NNB376-A.. / B..

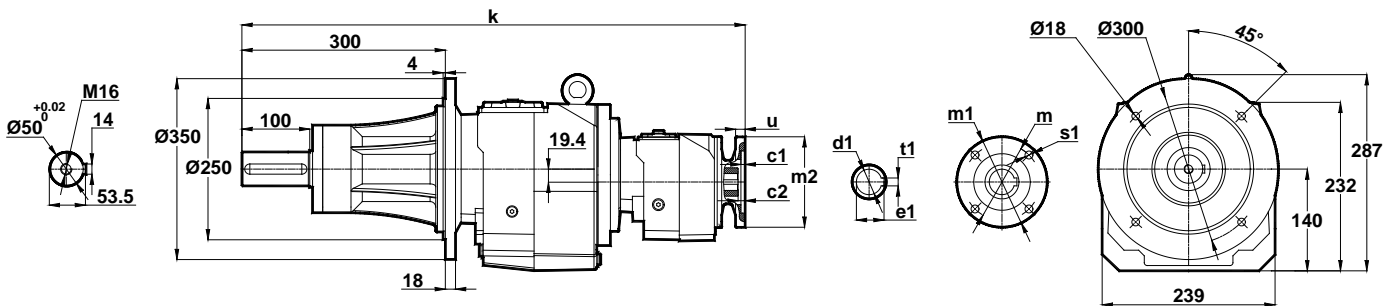

IEC	c1	c2	s1	m	m1	m2	u	k	d1	t1	e1
63/B5	3.5	5	10	115	140	95	10	727	11	4	12.8
63/B14	2.5	5	5.5	75	90	60	10	727	11	4	12.8



Ölçü Sayfaları

Dimension Pages

Abmessungsseiten



-Mil ucu çekirme deliği DIN 332 sayfa 2 / Tapped center hole to DIN 332, sheet 2 / Zentrierung mit gewinde DIN 332, Blatt 2

NNB472-A.. NNB473-A..

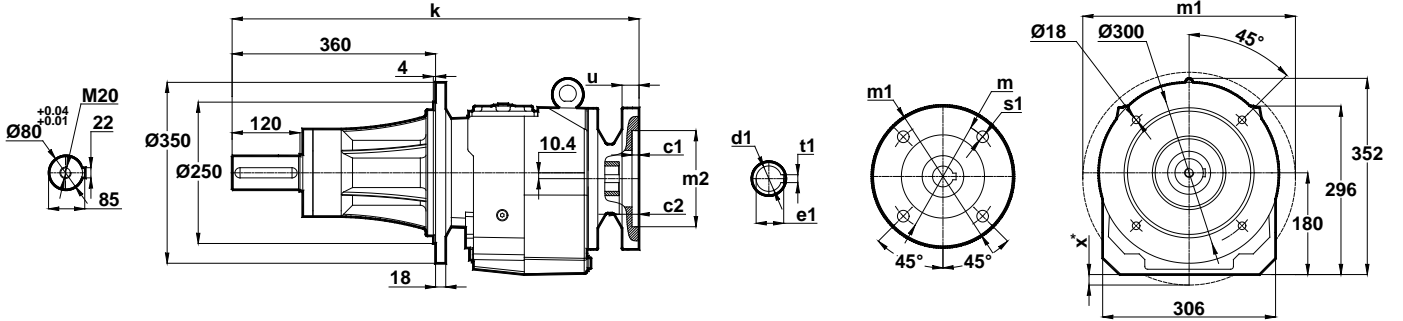

IEC	c1	c2	s1	m	m1	m2	u	k	d1	t1	e1	x
80/B5	4	5	12	165	200	130	12	687	19	6	21.8	-
90/B5	4	5	12	165	200	130	12	687	24	8	27.3	-
100/B5	4.5	9	15	215	250	180	15	705	28	8	31.3	-
112/B5	4.5	9	15	215	250	180	15	705	28	8	31.3	-
132/B5	4.5	6	15	265	300	230	15	724	38	10	41.3	-
160/B5	5.5	10	19	300	350	250	20	803	42	12	45.3	6
180/B5	5.5	10	19	300	350	250	20	803	48	14	51.8	6

NNB472-B.. NNB473-B..

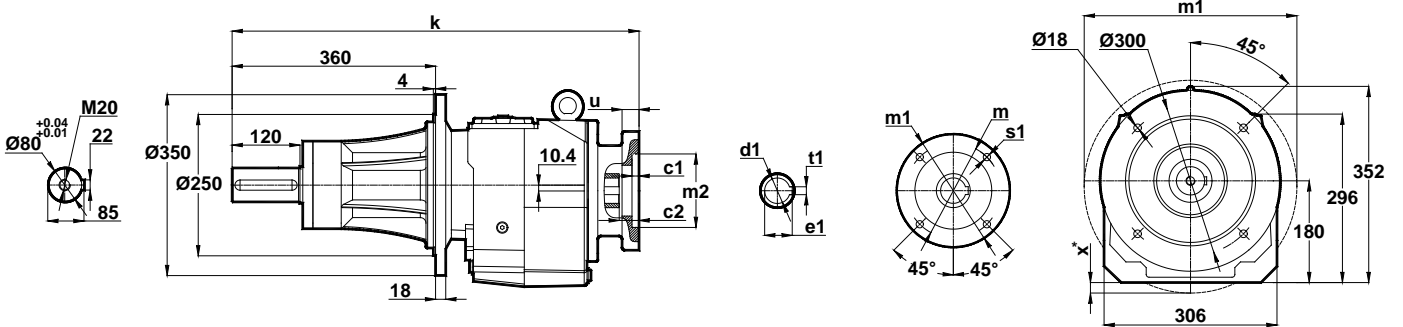

IEC	c1	c2	s1	m	m1	m2	u	k	d1	t1	e1	x
90/B14	4	5	9	115	140	95	12	687	24	8	27.3	-
100/B14	4	9	9	130	160	110	15	705	28	8	31.3	-
112/B14	4	9	9	130	160	110	15	705	28	8	31.3	-
132/B14	4.4	6	11	165	200	130	15	724	38	10	41.3	-

x: Motor Ayak bağlantı yüzeyinin altında ise / x: If Motor is lower than foot mounting plane / x: Wenn motor ist niedriger den die Anschlußplatte



Ölçü Sayfaları Dimension Pages Abmessungsseiten



-Mil ucu çekirme deliği DIN 332 sayfa 2 / Tapped center hole to DIN 332, sheet 2 / Zentrierung mit gewinde DIN 332, Blatt 2

NNB572-A.. / B.. NNB573-A.. / B..

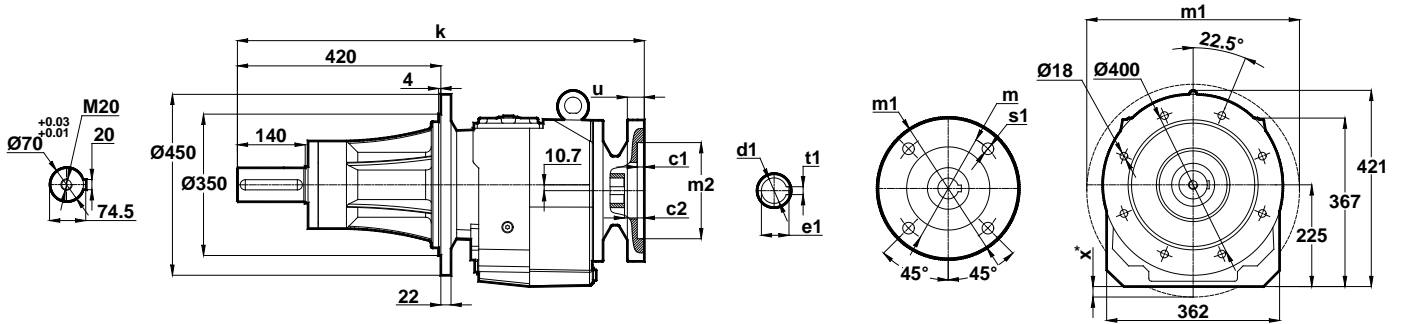

IEC	c1	c2	s1	m	m1	m2	u	k	d1	t1	e1	x
100/B5	4.5	20	15	215	250	180	15	827	28	8	31.3	-
112/B5	4.5	20	15	215	250	180	15	827	28	8	31.3	-
132/B5	4.5	9	15	265	300	230	15	848	38	10	41.3	-
160/B5	5.5	10	19	300	350	250	18	923	42	12	45.3	-
180/B5	5.5	10	19	300	350	250	18	923	48	14	51.8	-
200/B5	5.5	10	19	350	400	300	22	843	55	16	59.3	-
132/B14	4.5	9	11	165	200	130	15	848	38	10	41.3	-

NNB574-A.. NNB574-B..

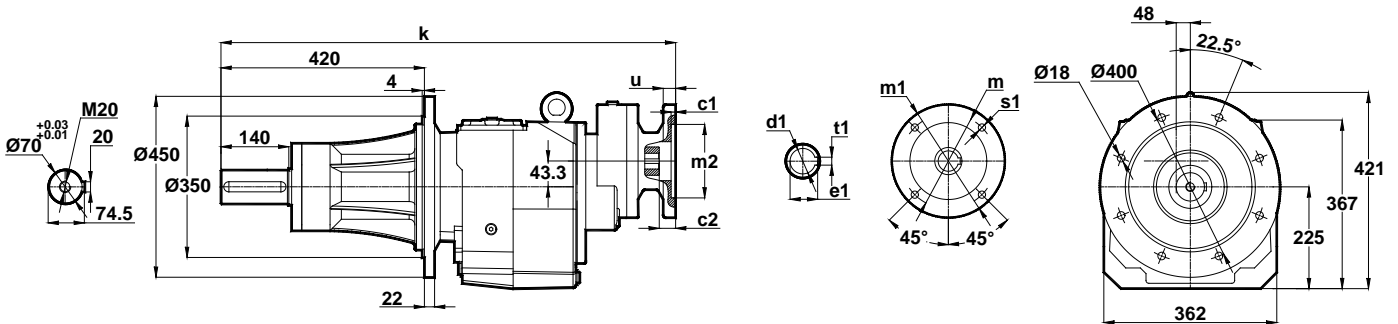

IEC	c1	c2	s1	m	m1	m2	u	k	d1	t1	e1
71/B5	4	9	11	130	160	110	12	670	14	5	16.3
80/B5	4	9	12	165	200	130	12	670	14	6	21.8
90/B5	4	9	12	165	200	130	12	670	19	8	27.3
80/B14	4	9	7	100	120	80	12	670	19	6	21.8
90/B14	4	9	9	115	140	95	12	670	24	8	26.3

x: Motor Ayak bağlantı yüzeyinin altında ise / x: If Motor is lower than foot mounting plane / x: Wenn motor ist niedriger den die Anschlußplatte

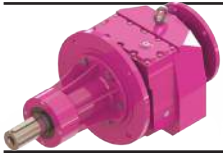

Ölçü Sayfaları Dimension Pages Abmessungenseiten



-Mil ucu çekirme deliği DIN 332 sayfa 2 / Tapped center hole to DIN 332, sheet 2 / Zentrierung mit gewinde DIN 332, Blatt 2

**NNB575-A.. / B..
NNB576-B.. / B..**

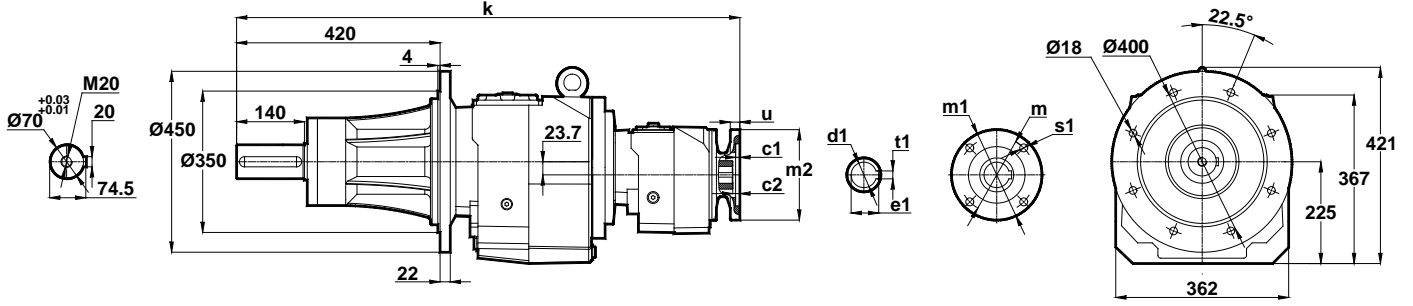

IEC	c1	c2	s1	m	m1	m2	u	k	d1	t1	e1
63/B5	4	5	9	115	140	95	12	800	11	4	12.8
71/B5	4	8.5	11	130	160	110	12	771	14	5	16.3
71/B14	3	8.5	7	85	105	70	10	771	14	5	16.3



Ölçü Sayfaları

Dimension Pages

Abmessungsseiten



-Mil ucu çekirme deliği DIN 332 sayfa 2 / Tapped center hole to DIN 332, sheet 2 / Zentrierung mit gewinde DIN 332, Blatt 2

NNB672-A.. / B..

NNB673-A.. / B..

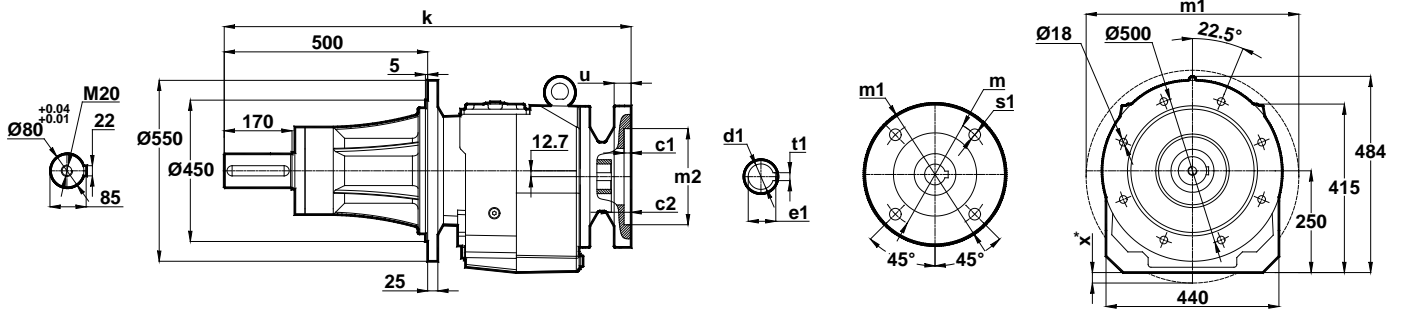

IEC	c1	c2	s1	m	m1	m2	u	k	d1	t1	e1	x
112/B5	4.5	14.5	15	215	250	180	15	928	28	8	31.3	-
132/B5	4.5	9	15	265	300	230	15	943	38	10	41.3	-
160/B5	5.5	10	19	300	350	250	20	1018	42	12	45.3	-
180/B5	5.5	10	19	300	350	250	20	1018	48	14	51.8	-
200/B5	5.5	10	19	350	400	300	22	1038	55	16	59.3	-
225/B5	5.5	10	19	400	450	350	24	1091	60	18	64.4	-
132/B14	4.5	9	15	165	200	130	15	943	38	10	41.3	-

NNB674-A..

NNB674-B..

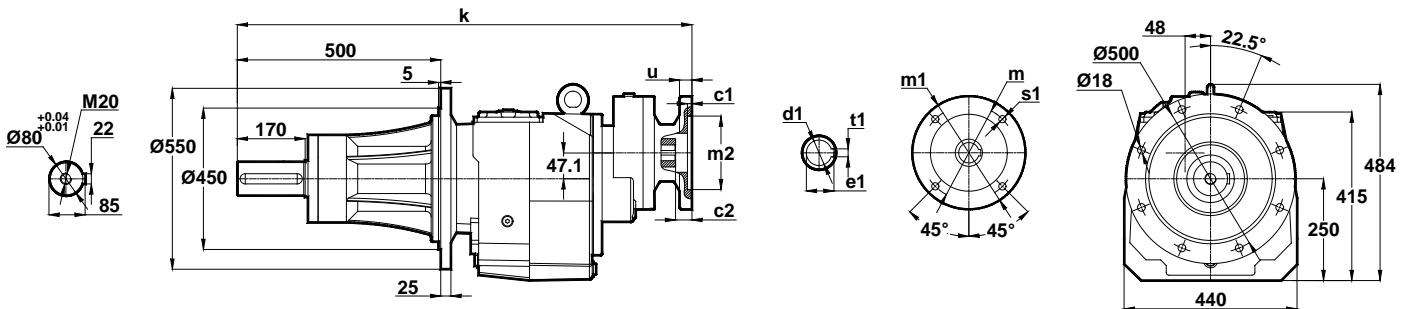

IEC	c1	c2	s1	m	m1	m2	u	k	d1	t1	e1
80/B5	4	5	12	165	200	130	12	1018	19	6	21.8
90/B5	4	5	12	165	200	130	12	1018	24	8	27.3
90/B14	4	5	9	115	140	95	12	1018	24	8	27.3

x: Motor Ayak bağlantı yüzeyinin altında ise / x: If Motor is lower then foot mounting plane / x: Wen motor ist niedriger den die Anschlußplatte



Ölçü Sayfaları

Dimension Pages

Abmessungsseiten



-Mil ucu çekirme deliği DIN 332 sayfa 2 / Tapped center hole to DIN 332, sheet 2 / Zentrierung mit gewinde DIN 332, Blatt 2

NNB675-A.. / B..
NNB676-B.. / B..

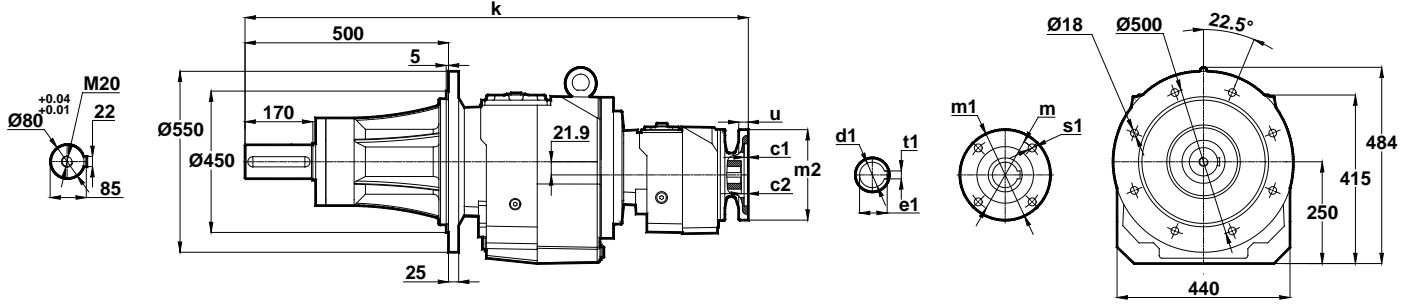

IEC	c1	c2	s1	m	m1	m2	u	k	d1	t1	e1
71/B5	4	9	11	130	160	110	12	1168	14	5	16.3
80/B5	4	9	12	165	200	130	12	1168	19	6	21.8
80/B14	4	9	7	100	120	80	12	1168	19	6	21.8



Ölçü Sayfaları

Dimension Pages

Abmessungsseiten



-Mil ucu çektirme deliği DIN 332 sayfa 2 / Tapped center hole to DIN 332, sheet 2 / Zentrierung mit gewinde DIN 332, Blatt 2

NNB772-A.. NNB773-A..

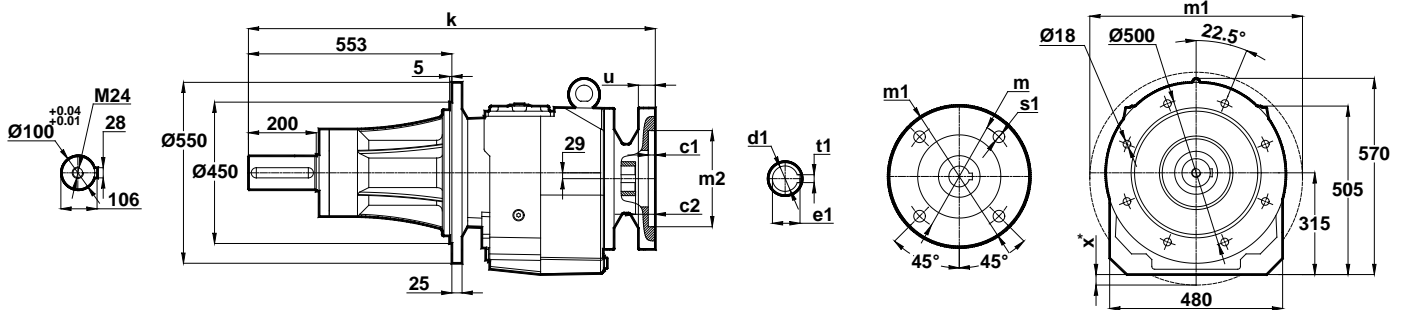

IEC	c1	c2	s1	m	m1	m2	u	k	d1	t1	e1	x
132/B5	4.5	15	15	265	300	230	15	1051	38	10	41.3	-
160/B5	5.5	10	19	300	350	250	20	1120	42	12	45.3	-
180/B5	5.5	10	19	300	350	250	20	1120	43	14	51.8	-
200/B5	5.5	10	19	350	400	300	20	1142	55	16	59.3	-
225/B5	5.5	10	19	400	450	350	24	1195	60	18	64.4	-
250/B5	5.5	10	19	500	550	450	24	1195	65	18	69.4	-

NNB774-A.. NNB774-B..

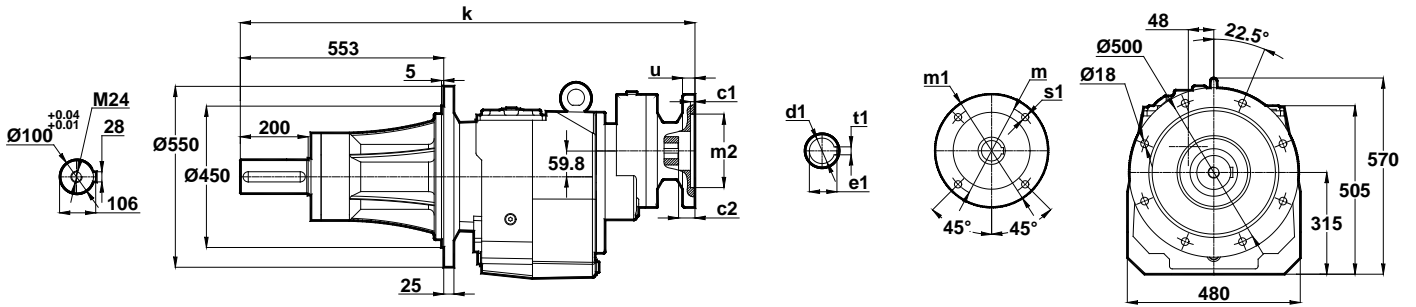

IEC	c1	c2	s1	m	m1	m2	u	k	d1	t1	e1
80/B5	4	5	12	165	200	130	12	1126	19	6	21.8
90/B5	4	5	12	165	200	130	12	1126	24	8	27.3
100/B5	4.5	9	15	215	250	180	15	1144	28	8	31.3
90/B14	4	5	9	115	140	95	12	1126	24	8	27.3
100/B14	4	9	9	130	160	110	15	1144	28	8	31.3

x: Motor Ayak bağlantı yüzeyinin altında ise / x: If Motor is lower than foot mounting plane / x: Wenn motor ist niedriger den die Anschlußplatte

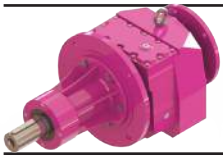

Ölçü Sayfaları Dimension Pages Abmessungsseiten



-Mil ucu çekirme deliği DIN 332 sayfa 2 / Tapped center hole to DIN 332, sheet 2 / Zentrierung mit gewinde DIN 332, Blatt 2

NNB775-A.. / B..
NNB776-B.. / B..

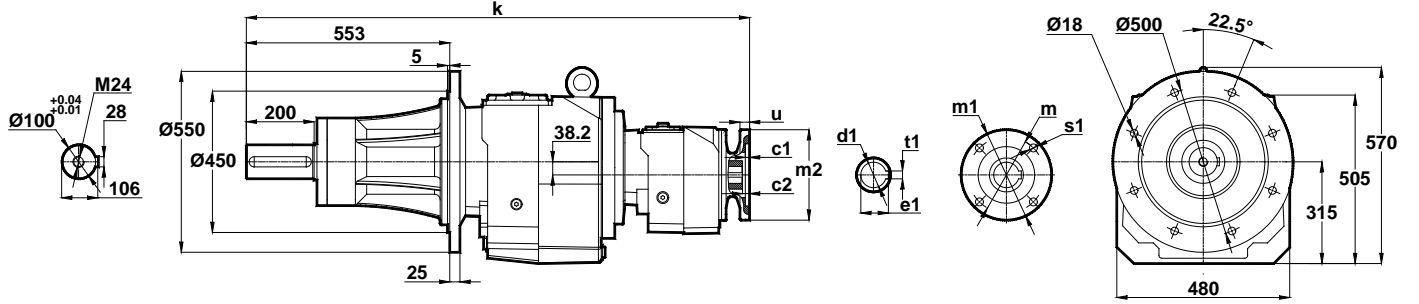

IEC	c1	c2	s1	m	m1	m2	u	k	d1	t1	e1
71/B5	4	9	11	130	160	110	12	1279	14	5	16.3
80/B5	4	9	12	165	200	130	12	1279	19	6	21.8
90/B5	4	9	12	165	200	130	12	1279	24	8	27.3
80/B14	4	9	7	100	120	80	12	1279	19	6	21.8
90/B14	4	9	9	115	140	95	12	1279	24	8	26.3

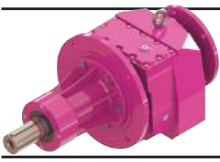

Ölçü Sayfaları

Dimension Pages

Abmessungsseiten



-Mil ucu çektirme deliği DIN 332 sayfa 2 / Tapped center hole to DIN 332, sheet 2 / Zentrierung mit gewinde DIN 332, Blatt 2

NNB872-A..

NNB873-A..

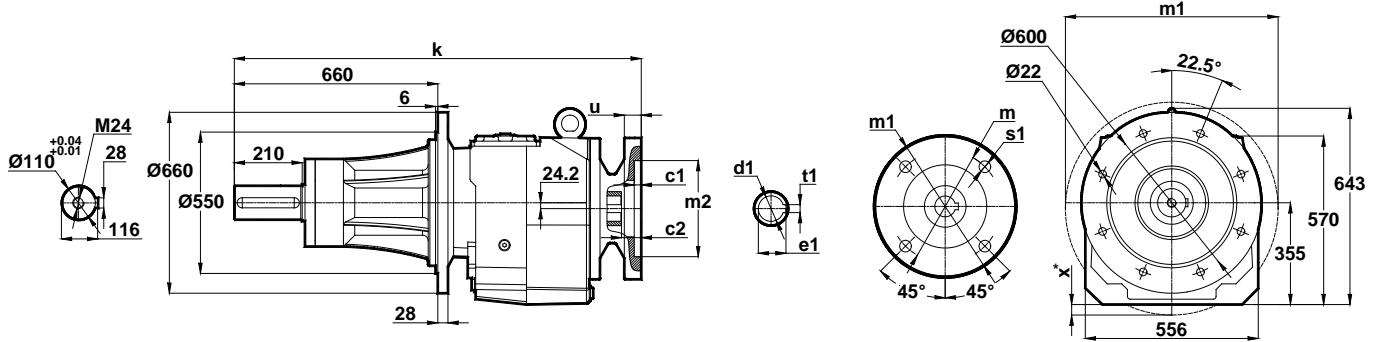

IEC	c1	c2	s1	m	m1	m2	u	k	d1	t1	e1	x
160/B5	5.5	10	19	300	350	250	20	1373	42	12	45.3	-
180/B5	5.5	10	19	300	350	250	20	1373	48	14	51.8	-
200/B5	5.5	10	19	350	400	300	22	1373	55	16	59.3	-
225/B5	5.5	10	19	400	450	350	24	1373	60	18	64.4	-
250/B5	5.5	10	19	500	550	450	24	1373	65	18	69.4	-
280/B5	5.5	10	19	500	550	450	24	1373	75	20	79.9	-

NNB874-A..

NNB874-B..

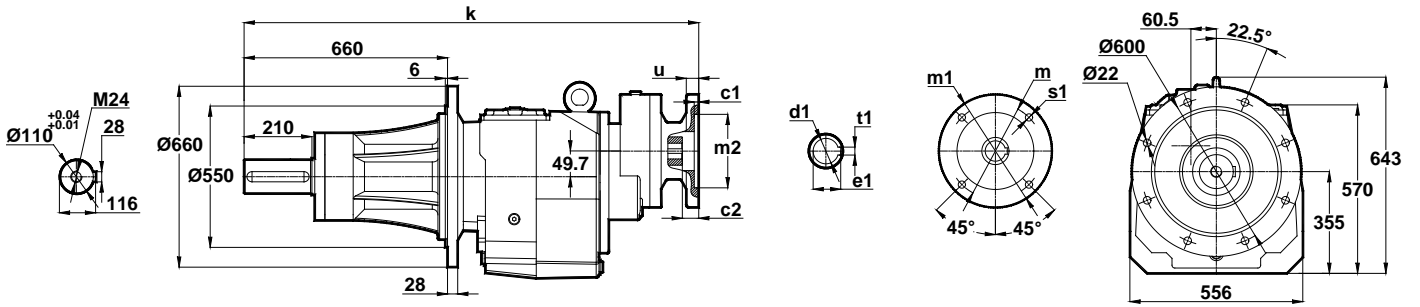

IEC	c1	c2	s1	m	m1	m2	u	k	d1	t1	e1
100/B5	4.5	20	15	215	250	180	15	1346	28	8	31.3
112/B5	4.5	20	15	215	250	180	15	1346	28	8	31.3
132/B5	4.5	9	15	265	300	230	15	1367	38	10	41.3
132/B14	4.5	9	11	165	200	130	15	1367	38	10	41.3

x: Motor Ayak bağlantı yüzeyinin altında ise / x: If Motor is lower than foot mounting plane / x: Wen motor ist niedriger den die Anschlußplatte

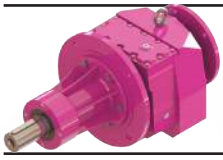

Ölçü Sayfaları Dimension Pages Abmessungenseiten



-Mil ucu çekirme deliği DIN 332 sayfa 2 / Tapped center hole to DIN 332, sheet 2 / Zentrierung mit gewinde DIN 332, Blatt 2

**NNB875-A.. / B..
NNB876-B.. / B..**

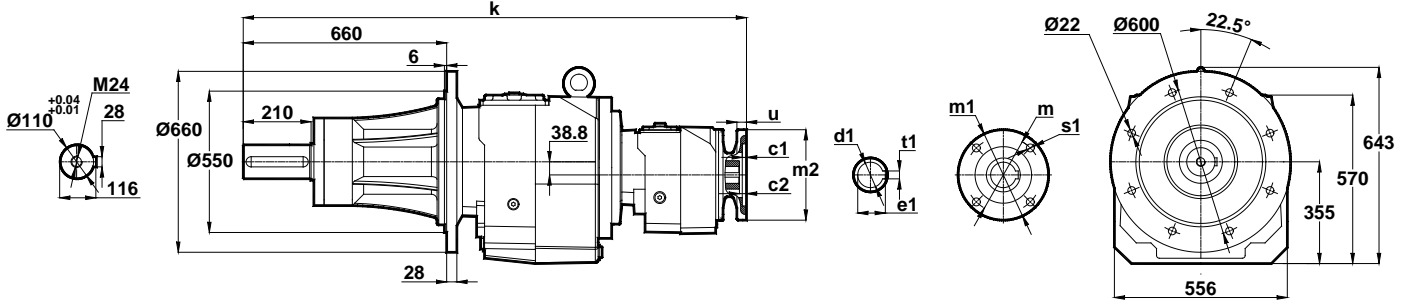

IEC	c1	c2	s1	m	m1	m2	u	k	d1	t1	e1
71/B5	4	9	11	130	160	110	12	1463	14	5	16.3
80/B5	4	9	12	165	200	130	12	1463	19	6	21.8
90/B5	4	9	12	165	200	130	12	1463	24	8	27.3
100/B5	4.5	9	15	215	250	180	15	1480	28	8	31.3
80/B14	4	9	7	100	120	80	12	1463	19	8	21.8
90/B14	4	9	9	115	140	95	12	1463	24	8	26.3
100/B14	4	9	9	130	160	110	15	1480	28	8	31.3



Ölçü Sayfaları

Dimension Pages

Abmessungsseiten



-Mil ucu çektirme deliği DIN 332 sayfa 2 / Tapped center hole to DIN 332, sheet 2 / Zentrierung mit gewinde DIN 332, Blatt 2

NNB972-A..

NNB973-A..

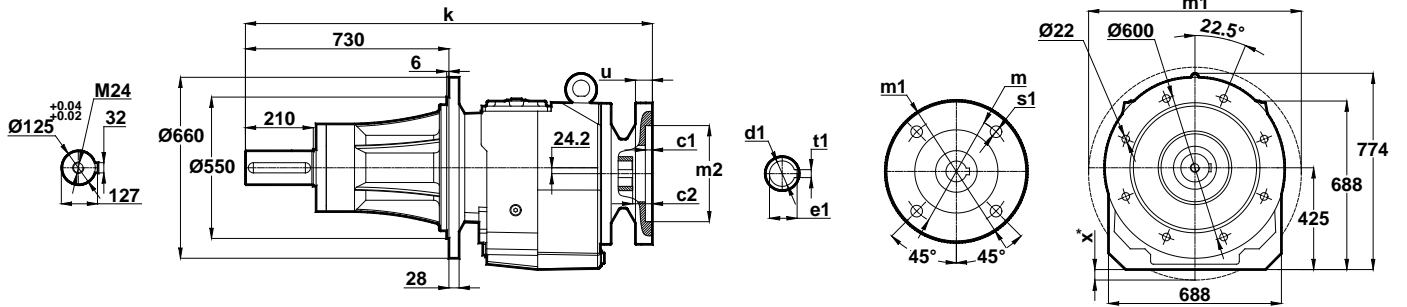

IEC	c1	c2	s1	m	m1	m2	u	k	d1	t1	e1	x
160/B5	5.5	10	19	300	350	250	20	1431	42	12	45.3	-
180/B5	5.5	10	19	300	350	250	20	1431	48	14	51.8	-
200/B5	5.5	10	19	350	400	300	22	1455	55	16	59.3	-
225/B5	5.5	10	19	400	450	350	24	1497	60	18	64.4	-
250/B5	5.5	10	19	500	550	450	24	1549	65	18	69.4	-
280/B5	5.5	10	19	500	550	450	24	1549	75	20	79.9	-
315/B5	6.5	15	24	660	600	550	24	1599	85	22	90.4	-

NNB974-A..

NNB974-B..

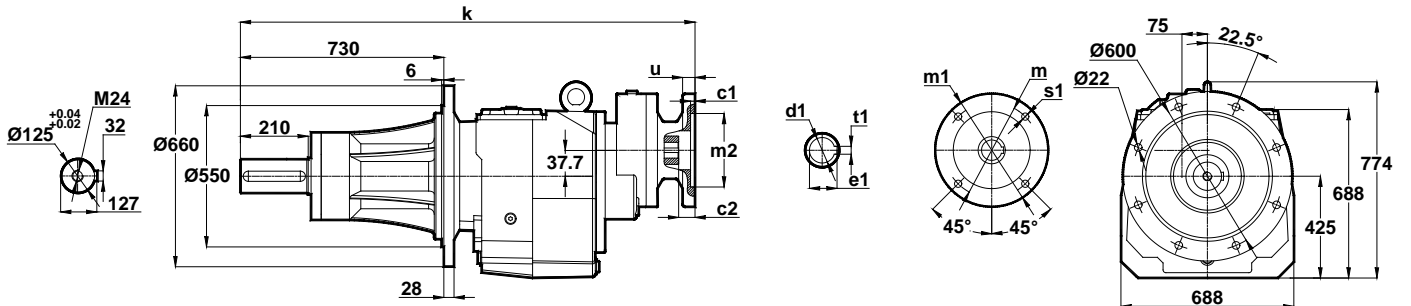

IEC	c1	c2	s1	m	m1	m2	u	k	d1	t1	e1
100/B5	4.5	14.5	15	215	250	180	15	1519	28	8	31.3
112/B5	4.5	14.5	15	215	250	180	15	1519	28	8	31.3
132/B5	4.5	9	15	265	300	230	15	1534	38	10	41.3
132/B14	4.5	9	15	165	200	130	15	1534	38	10	41.3

x: Motor Ayak bağlantı yüzeyinin altında ise / x: If Motor is lower than foot mounting plane / x: Wen motor ist nidriger den die Anschlußplatte

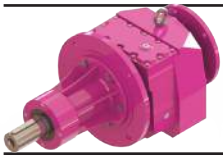

Ölçü Sayfaları Dimension Pages Abmessungsseiten



-Mil ucu çekirme deliği DIN 332 sayfa 2 / Tapped center hole to DIN 332, sheet 2 / Zentrierung mit gewinde DIN 332, Blatt 2

NNB975-A.. / B..
NNB976-B.. / B..

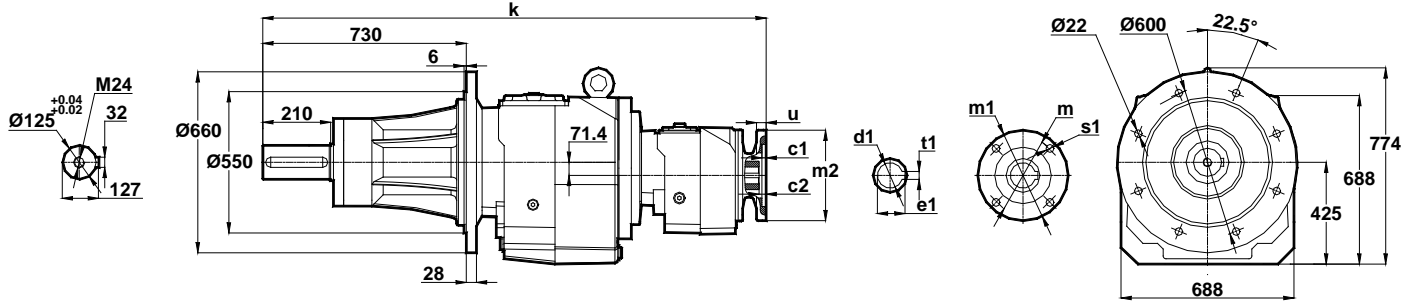

IEC	c1	c2	s1	m	m1	m2	u	k	d1	t1	e1
80/B5	4	5	12	165	200	130	12	1655	19	6	12.8
90/B5	4	5	12	165	200	130	12	1655	24	8	27.3
100/B5	4.5	9	15	215	250	180	15	1674	28	8	31.3
112/B5	4.5	9	15	215	250	180	15	1674	28	8	31.3
132/B5	4.5	6	15	265	300	230	15	1692	38	10	41.3
90/B14	4	5	9	115	140	95	12	1655	24	8	27.3
100/B14	4	9	9	130	160	110	15	1674	28	8	31.3
112/B14	4	9	9	130	160	110	15	1674	28	8	31.3
132/B14	4.4	6	11	165	200	130	15	1692	38	10	41.3

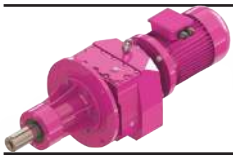

Ölçü Sayfaları Dimension Pages Abmessungsseiten



-Mil ucu çekirme deliği DIN 332 sayfa 2 / Tapped center hole to DIN 332, sheet 2 / Zentrierung mit gewinde DIN 332, Blatt 2

NVB202 NVB203

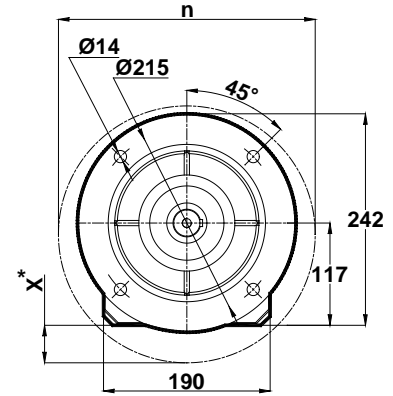
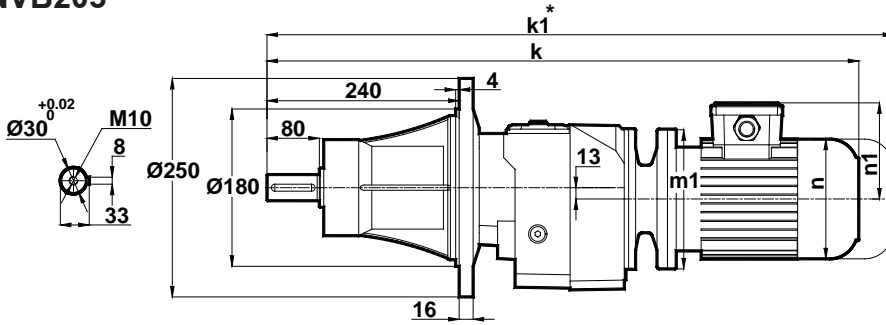

Motor Büyüklüğü / Motor Size / Motorbaugroße							
IEC	63/B5	71/B5 71/B14	80/B5 80/B14	90S/B5 90S/B14	90L/B5 90L/B14	100L/B5 100L/B14	112M/B5 112M/B14
k	696	693	742	962	787	812	832
k1	749	813	862	887	912	947	967
n / n1	121 / 97	138 / 111	156 / 118	176 / 126	176 / 126	194 / 135	218 / 146
m1 (B5)	140	160	200	200	200	250	250
m1 (B14)	-	105	120	140	140	160	160
x (B5)	-	-	-	-	-	23	23

Klemens Kutusu / Terminal Box / Klemmenkasten

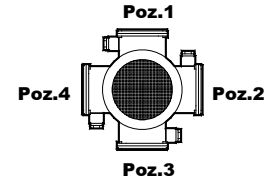

63-71-80-90-100-112

* " k1 " Ölçüsü frenli redüktörlere aittir. 63, 71 tip elektrik motorlu redüktörler soğutmasız, diğerleri soğutmalıdır.

Dimension " k1 " is for motors with brake. Gearboxes with 63 and 71 type electrical motors are not fan cooled, other types are fan cooled.

Maße " k1 " ist für Bremsenmotoren. Getrieben mit 63 und 71 typ Motoren sind ohne Kühlung, andere Typen sind mit Ventilator gekühlt.

x: Motor, ayak bağlantı yüzeyinin altında ise / x: If Motor is lower then foot mounting plane / x: Wenn motor ist niedriger den die Anschlußplatte

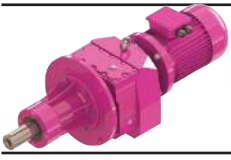

Ölçü Sayfaları Dimension Pages Abmessungsseiten



-Mil ucu çektirme deliği DIN 332 sayfa 2 / Tapped center hole to DIN 332, sheet 2 / Zentrierung mit gewinde DIN 332, Blatt 2

NVB272 NVB273

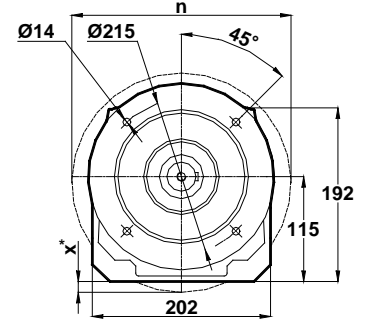
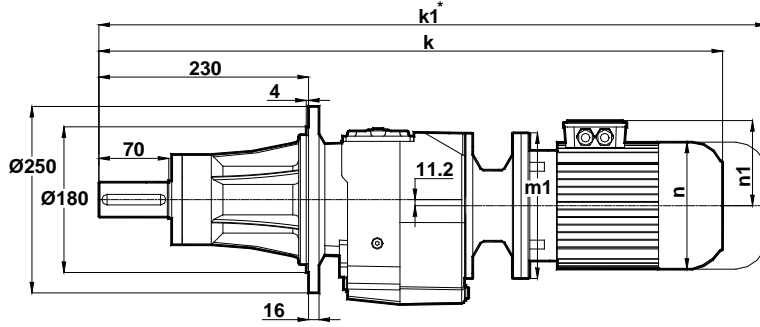
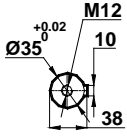

Motor Büyüklüğü / Motor Size / Motorbaugroße					
IEC	63/B5 63/B14	71/B5 71/B14	80/B5 80/B14	90S/B5 90S/B14	90L/B5 90L/B14
k	677	674	723	743	768
k1	730	794	843	868	893
n / n1	121 / 97	138 / 111	156 / 118	176 / 126	176 / 126
m1 (B5)	140	160	200	200	200
m1 (B14)	90	105	120	140	140
x (B5)	-	1	21	21	21

Klemens Kutusu / Terminal Box / Klemmenkasten

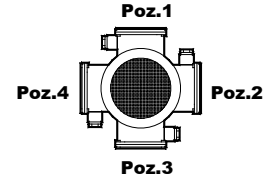

63-71-80-90

NVB275 NVB276

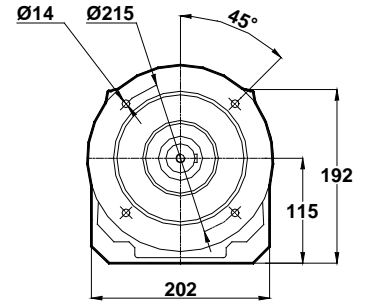
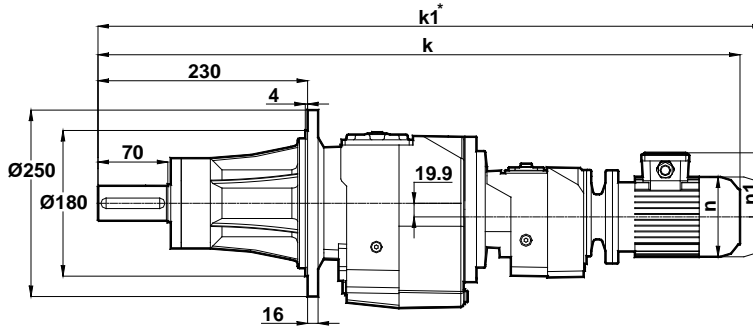
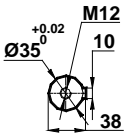

Motor Büyüklüğü / Motor Size / Motorbaugroße		
IEC	63/B5 63/B14	71/B5 71/B14
k	792	820
k1	845	940
n / n1	121 / 97	138 / 111
m1 (B5)	140	160
m1 (B14)	90	105

Klemens Kutusu / Terminal Box / Klemmenkasten

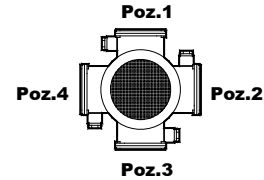

63-71

* " k1 " Ölçüsü frenli redüktörlere aittir. 63, 71 tip elektrik motorlu redüktörler soğutmasız, diğerleri soğutmalıdır.

Dimension " k1 " is for motors with brake. Gearboxes with 63 and 71 type electrical motors are not fan cooled, other types are fan cooled.

Maße " k1 " ist für Bremsenmotoren. Getrieben mit 63 und 71 typ Motoren sind ohne Kühlung, andere Typen sind mit Ventilator gekühlt.

x: Motor Ayak bağlantı yüzeyinin altında ise / x: If Motor is lower than foot mounting plane / x: Wenn motor ist niedriger den die Anschlußplatte

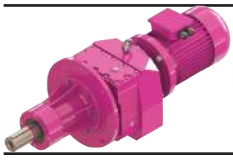

Ölçü Sayfaları Dimension Pages Abmessungsseiten



-Mil ucu çekirme deliği DIN 332 sayfa 2 / Tapped center hole to DIN 332, sheet 2 / Zentrierung mit gewinde DIN 332, Blatt 2

NVB282 NVB283

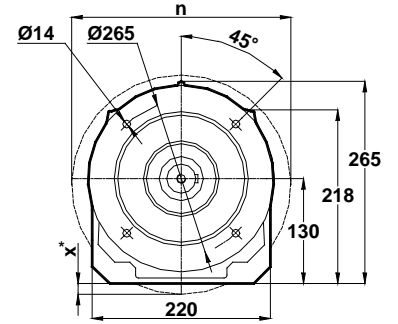
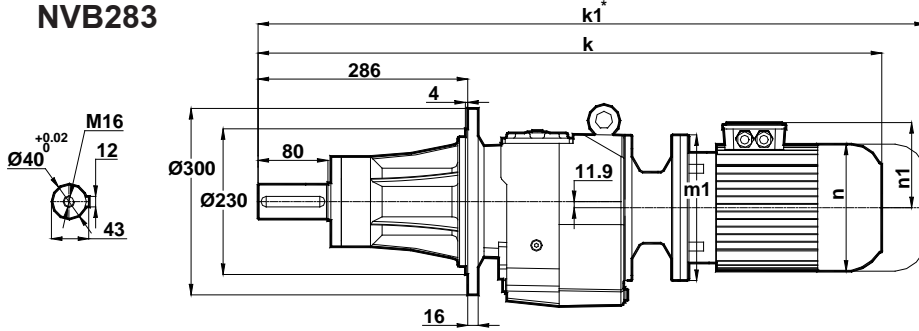

Motor Büyüklüğü / Motor Size / Motorbaugroße								
IEC	71/B5	80/B5 80/B14	90S/B5 90S/B14	90L/B5 90L/B14	100L/B5 100L/B14	112M/B5 112M/B14	132S/B5 132S/B14	132M/B5 132M/B14
k	778	798	818	843	882	902	976	1014
k1	898	918	943	968	1017	1037	1121	1159
n / n1	138 / 111	156 / 118	176 / 126	176 / 126	194 / 135	218 / 146	257 / 168	257 / 168
m1 (B5)	160	200	200	200	250	250	300	300
m1 (B14)	-	120	140	140	160	160	200	200
x (B5)	-	-	-	-	7	7	32	32

Klemens Kutusu / Terminal Box / Klemmenkasten

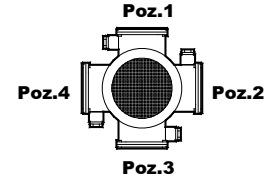

71-80-90-100-112-132

NVB284

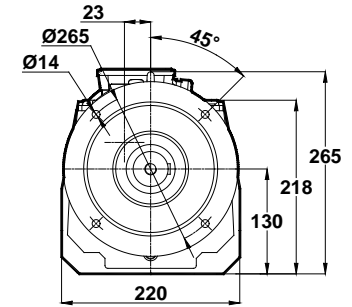
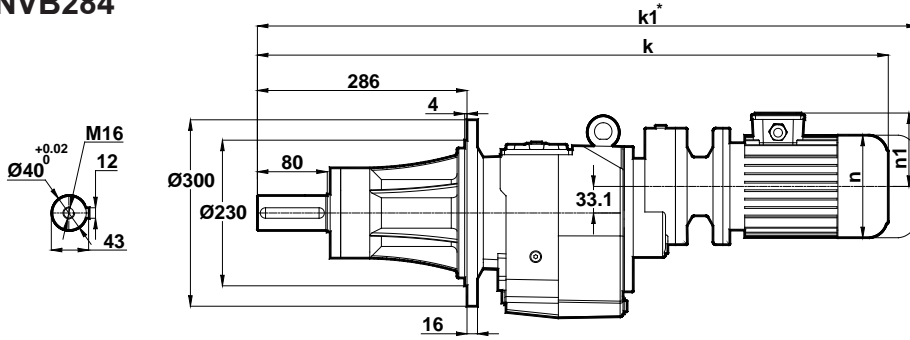

Motor Büyüklüğü / Motor Size / Motorbaugroße		
IEC	63/B5	71/B5 71/B14
k	829	826
k1	882	946
n / n1	121 / 97	138 / 111
m1 (B5)	140	160
m1 (B14)	-	105

Klemens Kutusu / Terminal Box / Klemmenkasten

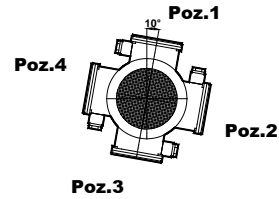

63-71

* " k1 " Ölçüsü frenli redüktörlere aittir. 63, 71 tip elektrik motorlu redüktörler soğutmasız, diğerleri soğutmalıdır.
Dimension " k1 " is for motors with brake. Gearboxes with 63 and 71 type electrical motors are not fan cooled, other types are fan cooled.
Maße " k1 " ist für Bremsenmotoren. Getrieben mit 63 und 71 typ Motoren sind ohne Kühlung, andere Typen sind mit Ventilator gekühlt.

x: Motor, ayak bağlantı yüzeyinin altında ise / x: If Motor is lower then foot mounting plane / x: Wenn motor ist niedriger den die Anschlußplatte

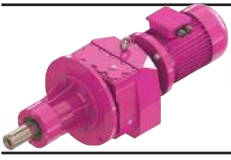

Ölçü Sayfaları Dimension Pages Abmessungsseiten



-Mil ucu çekirtme deliği DIN 332 sayfa 2 / Tapped center hole to DIN 332, sheet 2 / Zentrierung mit gewinde DIN 332, Blatt 2

NVB285
NVB286

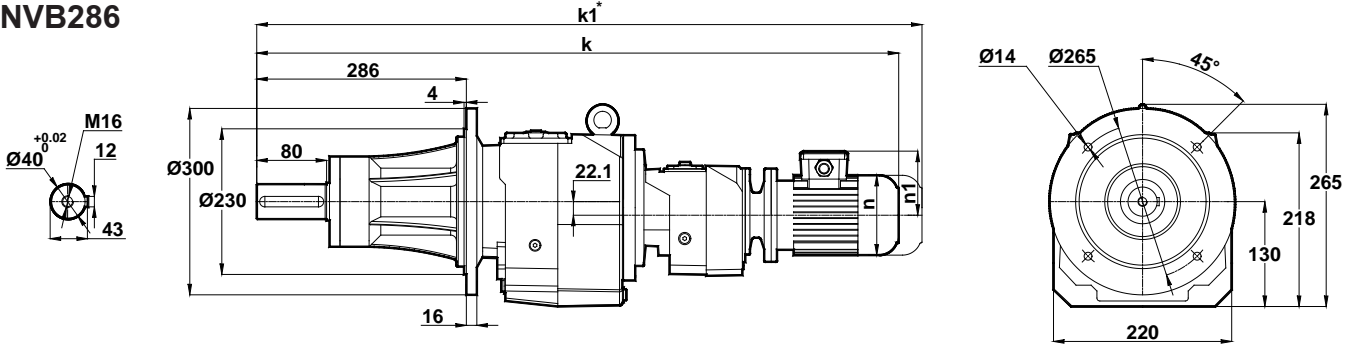

Motor Büyüklüğü / Motor Size / Motorbaugroße	
IEC	63/B5 63/B14
k	895
k1	948
n / n1	121 / 97
m1 (B5)	140
m1 (B14)	90

Klemens Kutusu / Terminal Box / Klemmenkasten

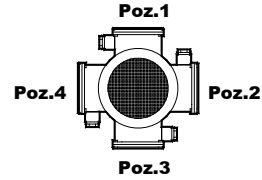

63

* " k1 " Ölçüsü frenli redüktörlere aittir. 63, 71 tip elektrik motorlu redüktörler soğutmasız, diğerleri soğutmalıdır.
Dimension " k1 " is for motors with brake. Gearboxes with 63 and 71 type electrical motors are not fan cooled, other types are fan cooled.
Maße " k1 " ist für Bremsenmotoren. Getrieben mit 63 und 71 typ Motoren sind ohne Kühlung, andere Typen zind mit Ventilator gekühlt.

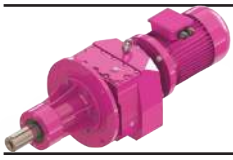

Ölçü Sayfaları Dimension Pages Abmessungsseiten



-Mil ucu çektirme deliği DIN 332 sayfa 2 / Tapped center hole to DIN 332, sheet 2 / Zentrierung mit gewinde DIN 332, Blatt 2

NVB372 NVB373

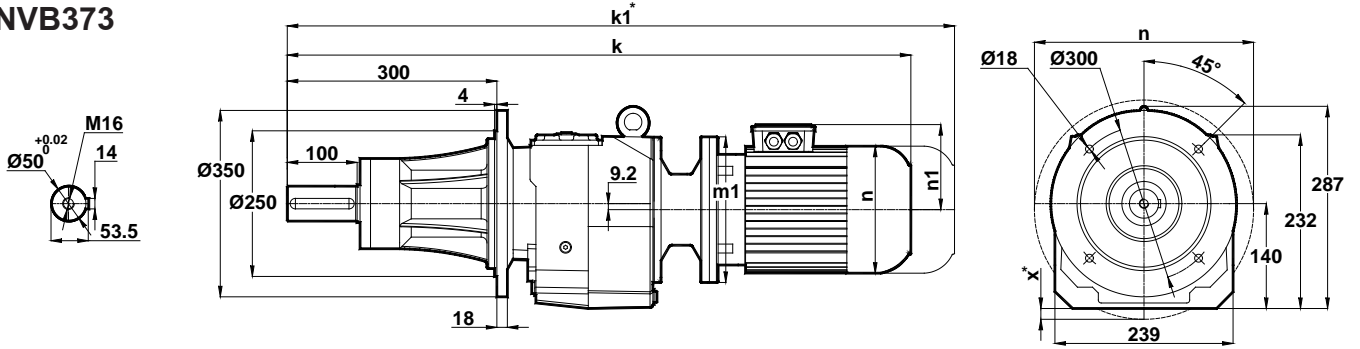

Motor Büyüklüğü / Motor Size / Motorbaugroße								
IEC	71/B5	80/B5 80/B14	90S/B5 90S/B14	90L/B5 90L/B14	100L/B5 100L/B14	112M/B5 112M/B14	132S/B5 132S/B14	132M/B5 132M/B14
k	803	823	843	868	917	937	1001	1039
k1	923	943	968	993	1052	1072	1146	1184
n / n1	138 / 111	156 / 118	176 / 126	176 / 126	194 / 135	218 / 146	257 / 168	257 / 168
m1 (B5)	160	200	200	200	250	250	300	300
m1 (B14)	-	120	140	140	160	160	200	200
x (B5)	-	-	-	-	-	-	20	20

Klemens Kutusu / Terminal Box / Klemmenkasten

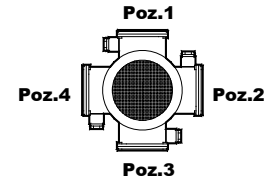

71-80-90-100-112-132

NVB374

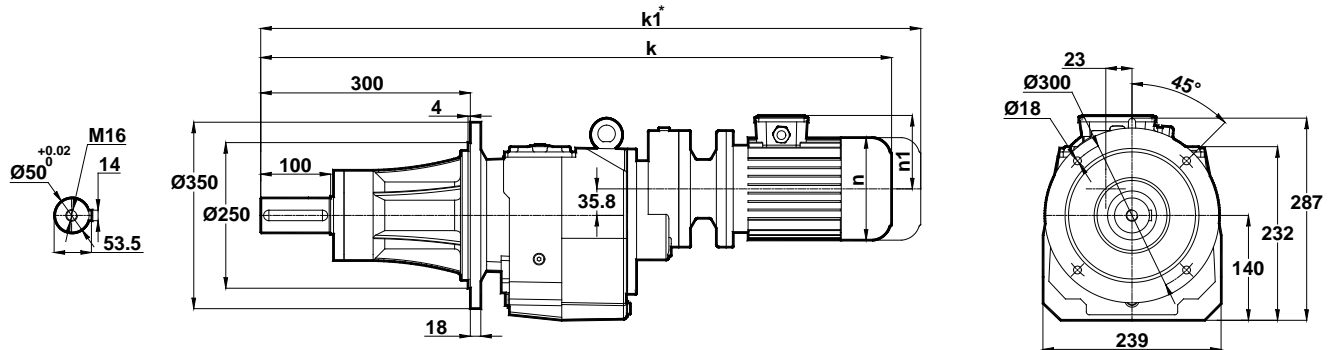

Motor Büyüklüğü / Motor Size / Motorbaugroße			
IEC	63/B5	71/B5 71/B14	80/B5 80/B14
k	854	851	900
k1	907	971	1020
n / n1	121 / 97	138 / 111	156 / 118
m1 (B5)	140	160	200
m1 (B14)	-	105	120

Klemens Kutusu / Terminal Box / Klemmenkasten

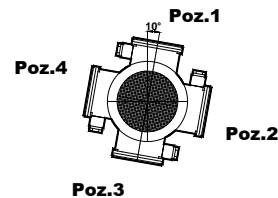

63-71-80

* " k1 " Ölçüsü frenli redüktörlere aittir. 63, 71 tip elektrik motorlu redüktörler soğutmasız, diğerleri soğutmalıdır.
Dimension " k1 " is for motors with brake. Gearboxes with 63 and 71 type electrical motors are not fan cooled, other types are fan cooled.
Maße " k1 " ist für Bremsenmotoren. Getrieben mit 63 und 71 typ Motoren sind ohne Kühlung, andere Typen sind mit Ventilator gekühlt.
x: Motor, ayak bağlantı yüzeyinin altında ise / x: If Motor is lower then foot mounting plane / x: Wenn motor ist niedriger den die Anschlußplatte

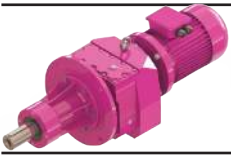

Ölçü Sayfaları Dimension Pages Abmessungsseiten



-Mil ucu çekirtme deliği DIN 332 sayfa 2 / Tapped center hole to DIN 332, sheet 2 / Zentrierung mit gewinde DIN 332, Blatt 2

NVB375
NVB376

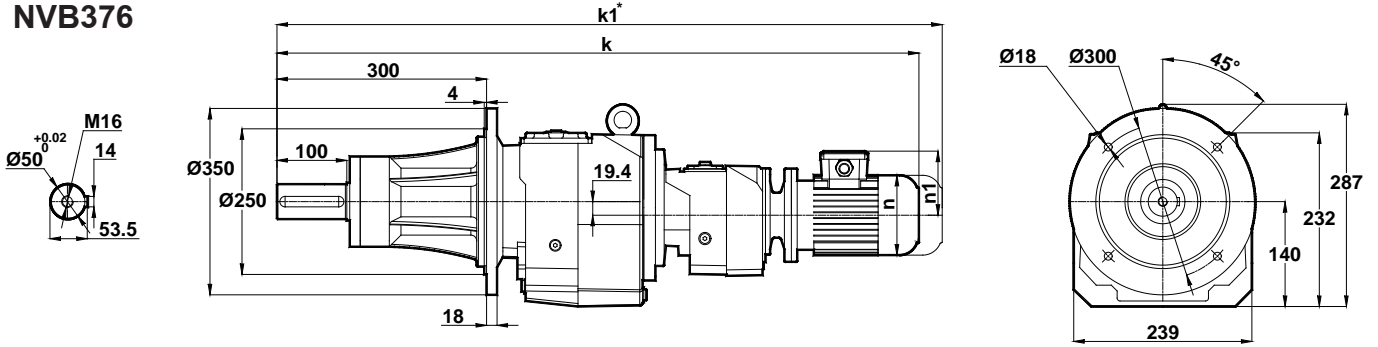

Motor Büyüklüğü / Motor Size / Motorbaugroße	
IEC	63/B5 63/B14
k	1033
k1	1086
n / n1	121 / 97
m1 (B5)	140
m1 (B14)	90

Klemens Kutusu / Terminal Box / Klemmenkasten

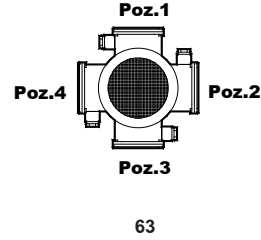

* " k1 " Ölçüsü frenli redüktörlere aittir. 63, 71 tip elektrik motorlu redüktörler soğutmasız, diğerleri soğutmalıdır.
Dimension " k1 " is for motors with brake. Gearboxes with 63 and 71 type electrical motors are not fan cooled, other types are fan cooled.
Maße " k1 " ist für Bremsenmotoren. Getrieben mit 63 und 71 typ Motoren sind ohne Kühlung, andere Typen zind mit Ventilator gekühlt.

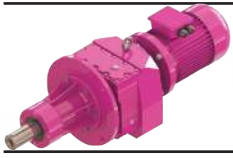

Ölçü Sayfaları Dimension Pages Abmessungsseiten



-Mil ucu çekirme deliği DIN 332 sayfa 2 / Tapped center hole to DIN 332, sheet 2 / Zentrierung mit gewinde DIN 332, Blatt 2

NVB472 NVB473

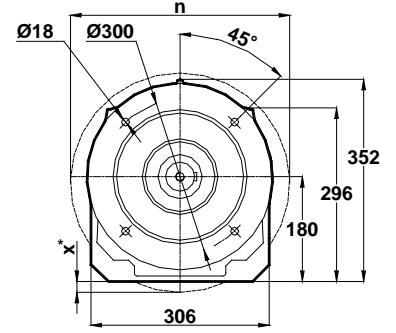
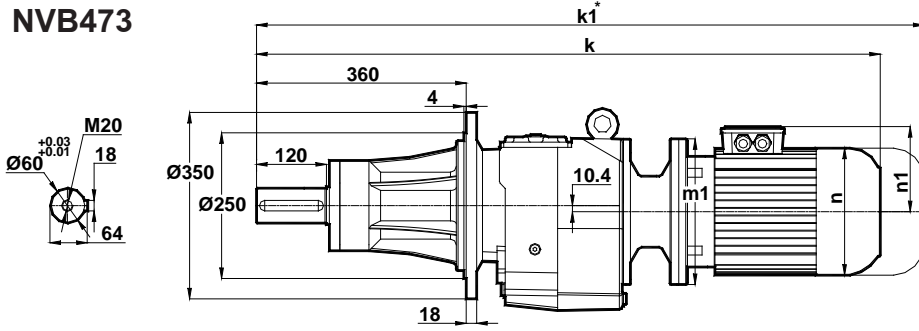

Motor Büyüklüğü / Motor Size / Motorbaugroße											
IEC	80/B5	90S/B5 90S/B14	90L/B5 90L/B14	100L/B5 100L/B14	112M/B5 112M/B14	132S/B5 132S/B14	132M/B5 132M/B14	160M/B5	160L/B5	180M/B5	180L/B5
k	926	946	971	1021	1041	1104	1142	1293	1337	1350	1388
k1	1046	1071	1096	1156	1176	1249	1287	1463	1507	1520	1558
n / n1	156 / 118	176 / 126	176 / 126	194 / 135	218 / 146	257 / 168	257 / 168	310 / 225	310 / 225	348 / 241	348 / 241
m1 (B5)	200	200	200	250	250	300	300	350	350	350	350
m1 (B14)	-	140	140	160	160	200	200	-	-	-	-
x (B5)	-	-	-	-	-	-	-	6	6	6	6

Klemens Kutusu / Terminal Box / Klemmenkasten

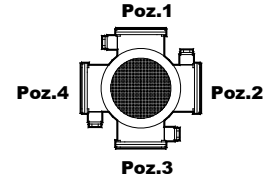

80-90-100-112-132-160-180

NVB474

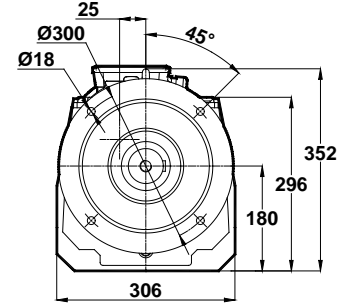
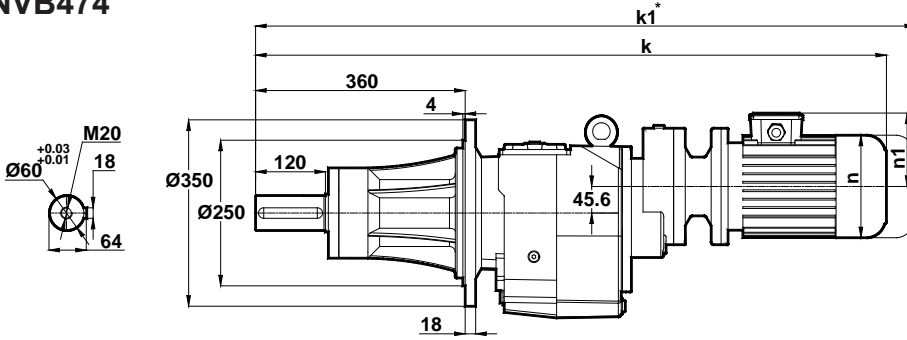

Motor Büyüklüğü / Motor Size / Motorbaugroße		
IEC	71/B5	80/B5 80/B14
k	1004	1024
k1	1124	1144
n / n1	138 / 111	156 / 118
m1 (B5)	160	200
m1 (B14)	-	120

Klemens Kutusu / Terminal Box / Klemmenkasten

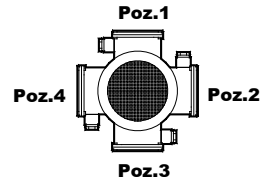

71-80

* " k1 " Ölçüsü frenli redüktörlere aittir. 63, 71 tip elektrik motorlu redüktörler soğutmasız, diğerleri soğutmalıdır.
Dimension " k1 " is for motors with brake. Gearboxes with 63 and 71 type electrical motors are not fan cooled, other types are fan cooled.

Maße " k1 " ist für Bremsenmotoren. Getrieben mit 63 und 71 typ Motoren sind ohne Kühlung, andere Typen sind mit Ventilator gekühlt.

x: Motor, ayak bağlantı yüzeyinin altında ise / x: If Motor is lower then foot mounting plane / x: Wenn motor ist niedriger den die Anschlußplatte

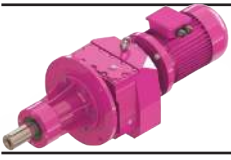

Ölçü Sayfaları Dimension Pages Abmessungenseiten



-Mil ucu çekirtme deliği DIN 332 sayfa 2 / Tapped center hole to DIN 332, sheet 2 / Zentrierung mit gewinde DIN 332, Blatt 2

NVB475 NVB476

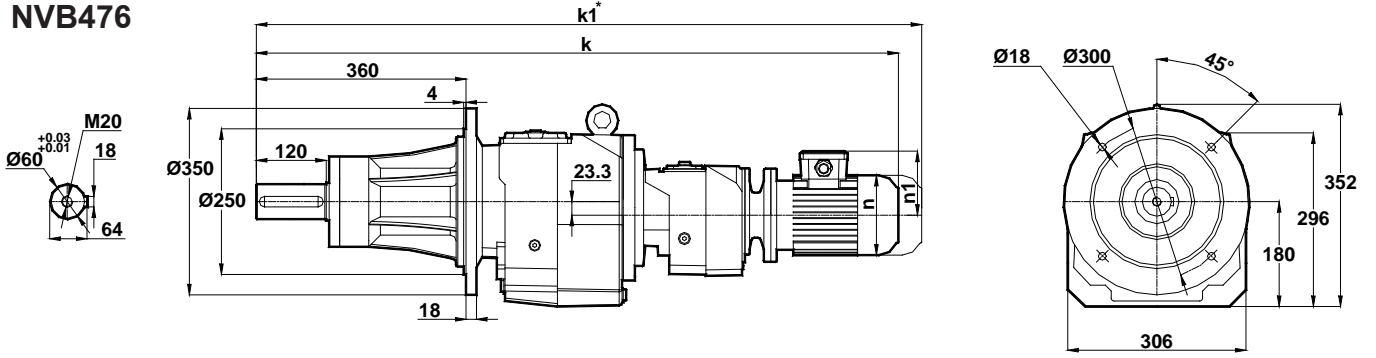

Motor Büyüklüğü / Motor Size / Motorbaugröße		
IEC	63/B5	71/B5 71/B14
k	1106	1103
k1	1159	1223
n / n1	121 / 97	138 / 111
m1 (B5)	140	160
m1 (B14)	-	105

Klemens Kutusu / Terminal Box / Klemmenkasten

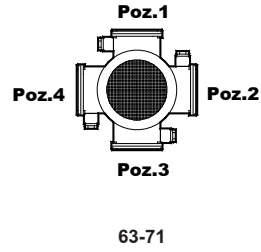

* " k1 " Ölçüsü frenli redüktörlere aittir. 63, 71 tip elektrik motorlu redüktörler soğutmasız, diğerleri soğutmalıdır.
Dimension " k1 " is for motors with brake. Gearboxes with 63 and 71 type electrical motors are not fan cooled, other types are fan cooled.
Maße " k1 " ist für Bremsenmotoren. Getrieben mit 63 und 71 typ Motoren sind ohne Kühlung, andere Typen sind mit Ventilator gekühlt.

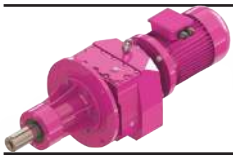

Ölçü Sayfaları Dimension Pages Abmessungsseiten



-Mil ucu çekirme deliği DIN 332 sayfa 2 / Tapped center hole to DIN 332, sheet 2 / Zentrierung mit gewinde DIN 332, Blatt 2

NVB572 NVB573

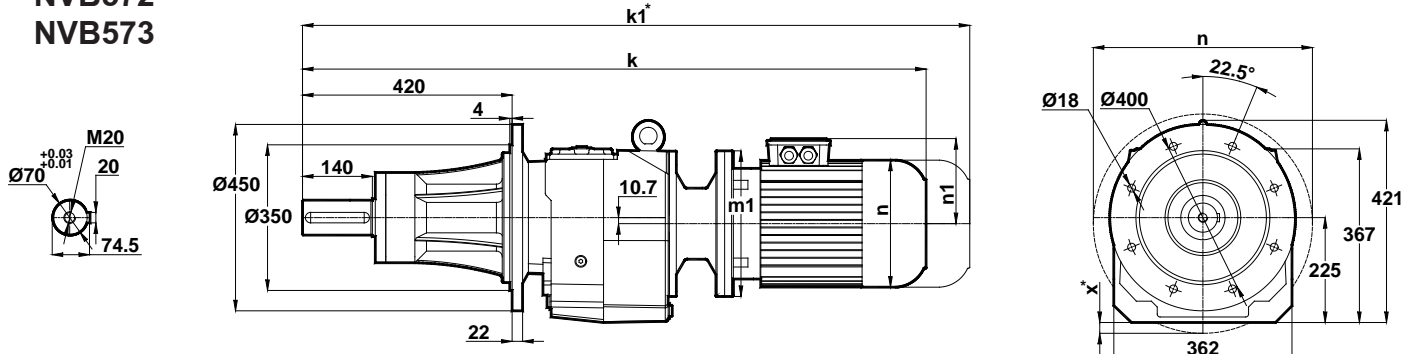

Motor Büyüklüğü / Motor Size / Motorbaugroße									
IEC	100L/B5	112M/B5	132S/B5 132S/B14	132M/B5 132M/B14	160M/B5	160L/B5	180M/B5	180L/B5	200L/B5
k	1143	1163	1228	1266	1413	1457	1470	1508	1580
k1	1278	1298	1373	1411	1583	1627	1640	1678	1780
n / n1	194 / 135	218 / 146	257 / 168	257 / 168	310 / 225	310 / 225	348 / 241	348 / 241	390 / 275
m1 (B5)	250	250	300	300	350	350	350	350	400
m1 (B14)	-	-	200	200	-	-	-	-	-
x (B5)	-	-	-	-	-	-	-	-	-

Klemens Kutusu / Terminal Box / Klemmenkasten

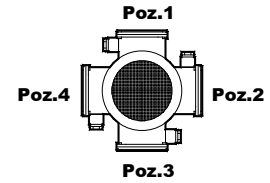

100-112-132-160-180-200

NVB574

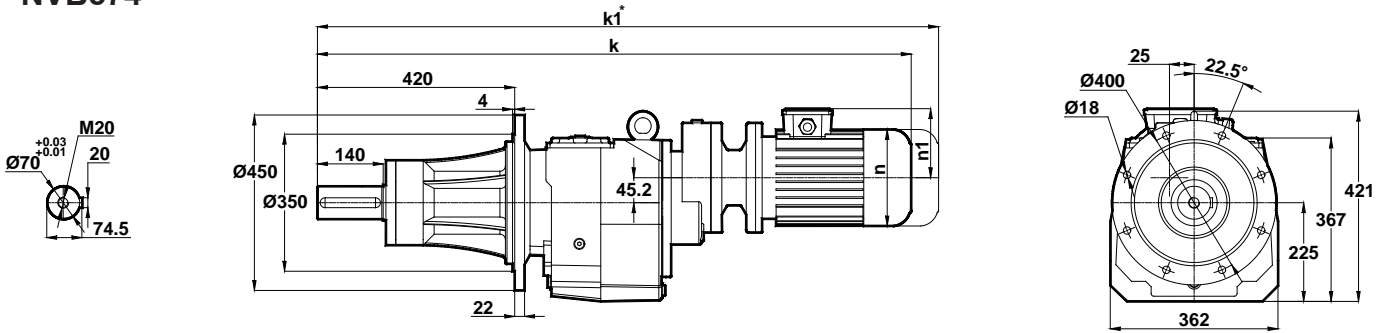

Motor Büyüklüğü / Motor Size / Motorbaugroße				
IEC	71/B5	80/B5 80/B14	90S/B5 90S/B14	90L/B5 90L/B14
k	1126	1146	1166	1191
k1	1246	1266	1291	1316
n / n1	138 / 111	156 / 118	176 / 126	176 / 126
m1 (B5)	160	200	200	200
m1 (B14)	-	120	140	140

Klemens Kutusu / Terminal Box / Klemmenkasten

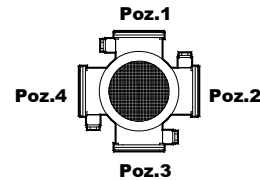

71-80-90

* " k1 " Ölçüsü frenli redüktörlere aittir. 63, 71 tip elektrik motorlu redüktörler soğutmasız, diğerleri soğutmalıdır.
Dimension " k1 " is for motors with brake. Gearboxes with 63 and 71 type electrical motors are not fan cooled, other types are fan cooled.
Maße " k1 " ist für Bremsenmotoren. Getrieben mit 63 und 71 typ Motoren sind ohne Kühlung, andere Typen sind mit Ventilator gekühlt.
x: Motor, ayak bağlantı yüzeyinin altında ise / x: If Motor is lower then foot mounting plane / x: Wenn motor ist niedriger den die Anschlußplatte

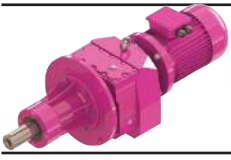

Ölçü Sayfaları Dimension Pages Abmessungsseiten



-Mil ucu çekirtme deliği DIN 332 sayfa 2 / Tapped center hole to DIN 332, sheet 2 / Zentrierung mit gewinde DIN 332, Blatt 2

NVB575
NVB576

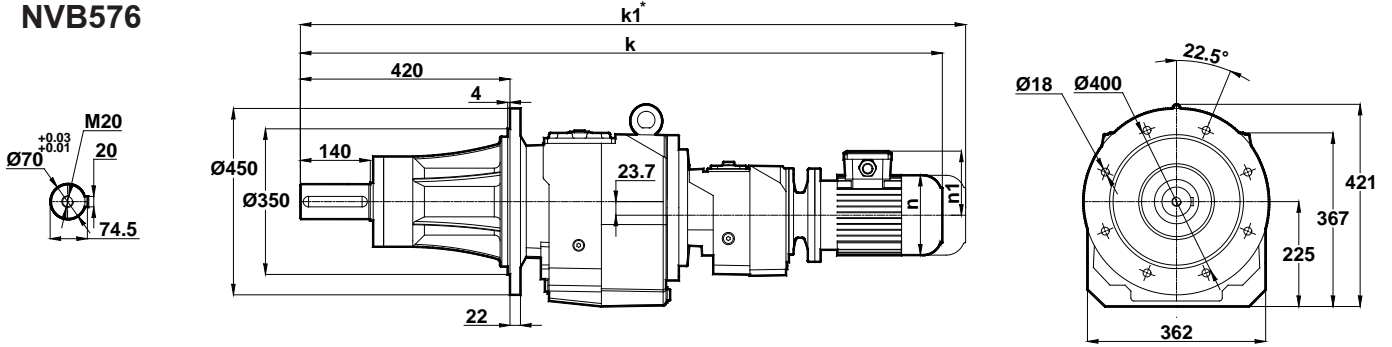

Motor Büyüklüğü / Motor Size / Motorbaugroße		
IEC	63/B5	71/B5 71/B14
k	1230	1227
k1	1283	1347
n / n1	121 / 97	138 / 111
m1 (B5)	140	160
m1 (B14)	-	105

Klemens Kutusu / Terminal Box / Klemmenkasten

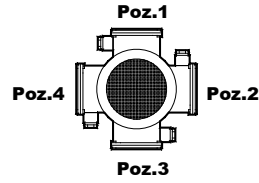

63-71

* " k1 " Ölçüsü frenli redüktörlere aittir. 63, 71 tip elektrik motorlu redüktörler soğutmasız, diğerleri soğutmalıdır.

Dimension " k1 " is for motors with brake. Gearboxes with 63 and 71 type electrical motors are not fan cooled, other types are fan cooled.

Maße " k1 " ist für Bremsenmotoren. Getrieben mit 63 und 71 typ Motoren sind ohne Kühlung, andere Typen sind mit Ventilator gekühlt.

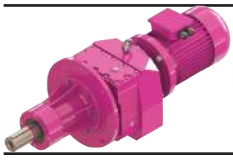

Ölçü Sayfaları Dimension Pages Abmessungsseiten



-Mil ucu çektirme deliği DIN 332 sayfa 2 / Tapped center hole to DIN 332, sheet 2 / Zentrierung mit gewinde DIN 332, Blatt 2

NVB672 NVB673

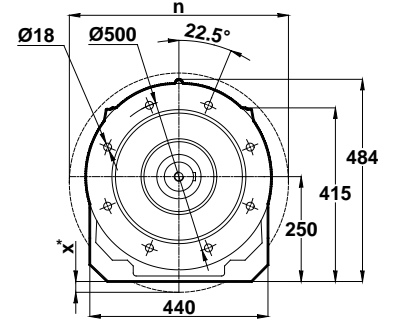
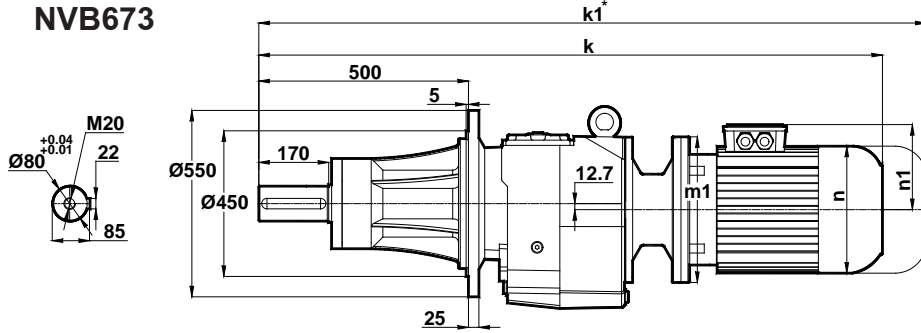

Motor Büyüklüğü / Motor Size / Motorbaugroße										
IEC	112M/B5	132S/B5 132S/B14	132M/B5 132M/B14	160M/B5	160L/B5	180M/B5	180L/B5	200L/B5	225S/B5	225M/B5
k	1264	1323	1361	1508	1552	1565	1705	1779	1850	1875
k1	1399	1468	1506	1678	1722	1735	1875	1979	2040	2065
n / n1	218 / 146	257 / 168	257 / 168	310 / 225	310 / 225	348 / 241	348 / 241	390 / 275	434 / 285	434 / 285
m1 (B5)	250	300	300	350	350	350	350	400	450	450
m1 (B14)	-	200	200	-	-	-	-	-	-	-
x (B5)	-	-	-	-	-	-	-	-	-	-

Klemens Kutusu / Terminal Box / Klemmenkasten

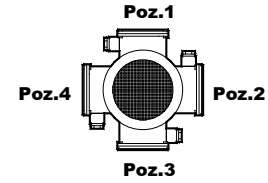

112-132-160-180-200-225

NVB674

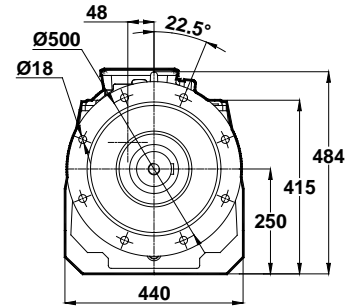
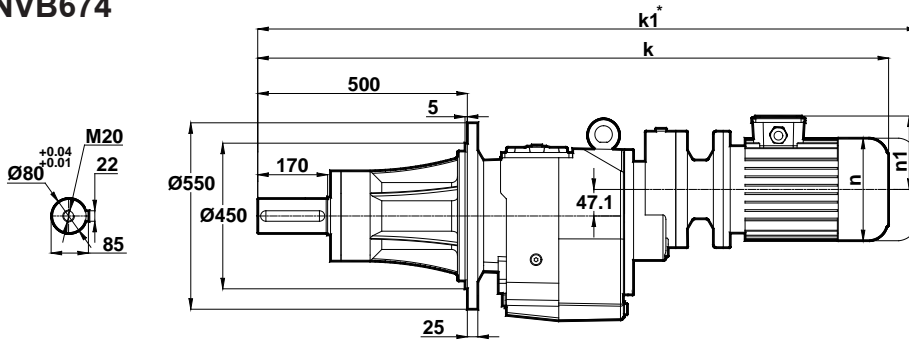

Motor Büyüklüğü / Motor Size / Motorbaugroße			
IEC	80/B5	90S/B5 90S/B14	90L/B5 90L/B14
k	1257	1277	1302
k1	1377	1402	1427
n / n1	156 / 118	176 / 126	176 / 126
m1 (B5)	200	200	200
m1 (B14)	-	140	140

Klemens Kutusu / Terminal Box / Klemmenkasten

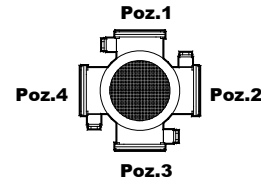

80-90

* " k1 " Ölçüsü frenli redüktörlere aittir. 63, 71 tip elektrik motorlu redüktörler soğutmasız, diğerleri soğutmalıdır.
Dimension " k1 " is for motors with brake. Gearboxes with 63 and 71 type electrical motors are not fan cooled, other types are fan cooled.
Maße " k1 " ist für Bremsenmotoren. Getrieben mit 63 und 71 typ Motoren sind ohne Kühlung, andere Typen sind mit Ventilator gekühlt.
x: Motor, ayak bağlantı yüzeyinin altında ise / x: If Motor is lower then foot mounting plane / x: Wenn motor ist niedriger den die Anschlußplatte

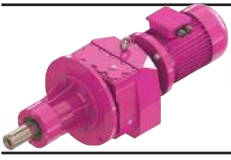

Ölçü Sayfaları Dimension Pages Abmessungsseiten



-Mil ucu çekirtme deliği DIN 332 sayfa 2 / Tapped center hole to DIN 332, sheet 2 / Zentrierung mit gewinde DIN 332, Blatt 2

NVB675
NVB676

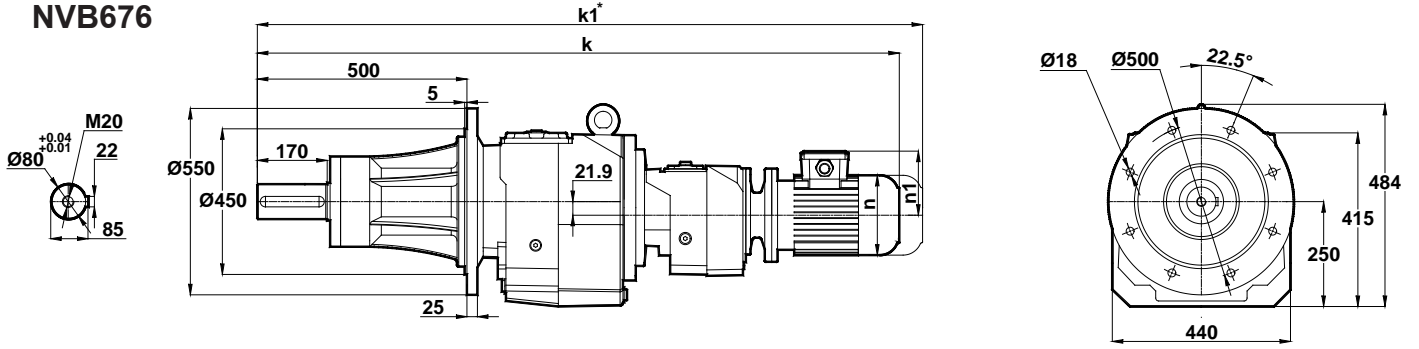

Motor Büyüklüğü / Motor Size / Motorbaugroße		
IEC	71/B5	80/B5 80/B14
k	1387	1407
k1	1507	1527
n / n1	138 / 111	156 / 118
m1 (B5)	160	200
m1 (B14)	-	120

Klemens Kutusu / Terminal Box / Klemmenkasten

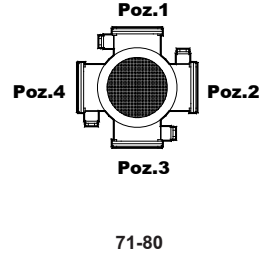

* " k1 " Ölçüsü frenli redüktörlere aittir. 63, 71 tip elektrik motorlu redüktörler soğutmasız, diğerleri soğutmalıdır.
Dimension " k1 " is for motors with brake. Gearboxes with 63 and 71 type electrical motors are not fan cooled, other types are fan cooled.
Maße " k1 " ist für Bremsenmotoren. Getrieben mit 63 und 71 typ Motoren sind ohne Kühlung, andere Typen sind mit Ventilator gekühlt.

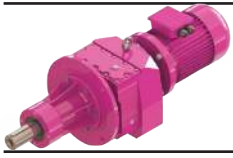

Ölçü Sayfaları Dimension Pages Abmessungsseiten



-Mil ucu çekirme deliği DIN 332 sayfa 2 / Tapped center hole to DIN 332, sheet 2 / Zentrierung mit gewinde DIN 332, Blatt 2

NVB772 NVB773

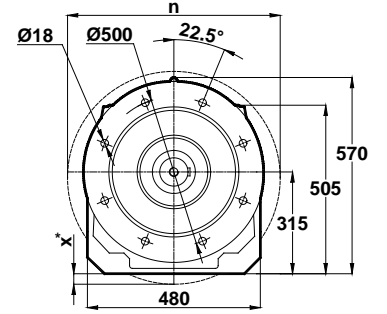
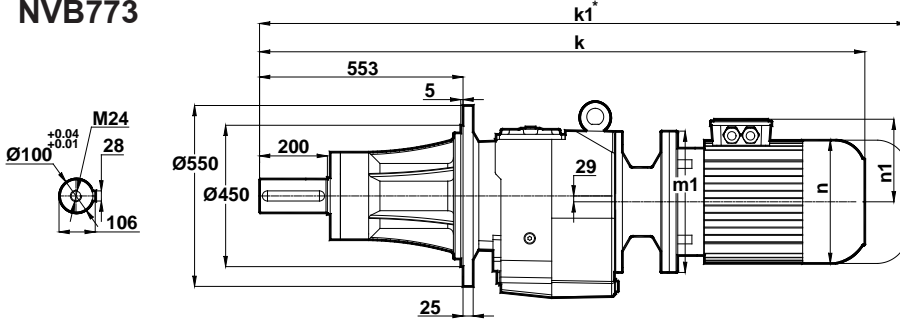

Motor Büyüklüğü / Motor Size / Motorbaugröße										
IEC	132S/B5	132M/B5	160M/B5	160L/B5	180M/B5	180L/B5	200L/B5	225S/B5	225M/B5	250M/B5
k	1431	1469	1610	1654	1667	1705	1779	1850	1875	1951
k1	1576	1614	1780	1824	1837	1875	1979	2040	2065	-
n / n1	257 / 168	257 / 168	310 / 225	310 / 225	348 / 241	348 / 241	434 / 285	434 / 285	434 / 285	480 / 322
m1 (B5)	300	300	350	350	350	350	400	450	450	550
m1 (B14)	-	-	-	-	-	-	-	-	-	-
x (B5)	-	-	-	-	-	-	-	-	-	-

Klemens Kutusu / Terminal Box / Klemmenkasten

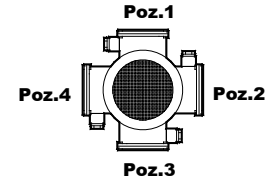

132-160-180-200-225-250

NVB774

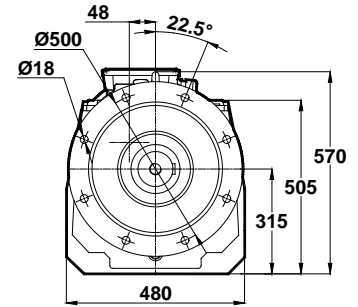
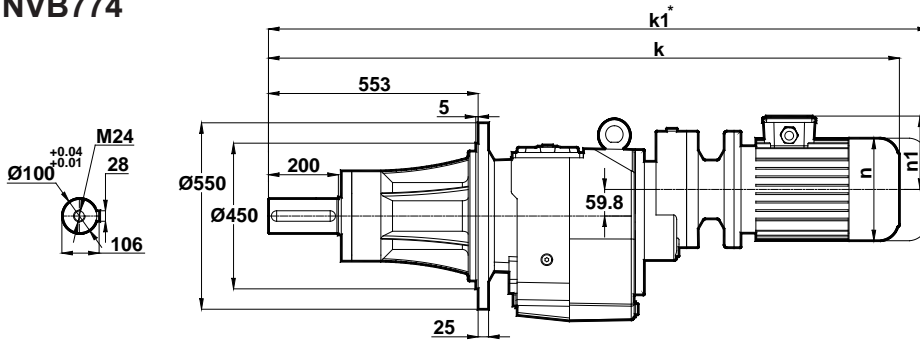

Motor Büyüklüğü / Motor Size / Motorbaugröße				
IEC	80/B5	90S/B5 90S/B14	90L/B5 90L/B14	100L/B5 100L/B14
k	1365	1385	1410	1460
k1	1485	1510	1535	1595
n / n1	156 / 118	176 / 126	176 / 126	194 / 135
m1 (B5)	200	200	200	250
m1 (B14)	-	140	140	160

Klemens Kutusu / Terminal Box / Klemmenkasten

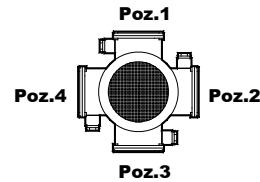

80-90-100

* " k1 " Ölçüsü frenli redüktörlere aittir. 63, 71 tip elektrik motorlu redüktörler soğutmasız, diğerleri soğutmalıdır.
Dimension " k1 " is for motors with brake. Gearboxes with 63 and 71 type electrical motors are not fan cooled, other types are fan cooled.
Maße " k1 " ist für Bremsenmotoren. Getrieben mit 63 und 71 typ Motoren sind ohne Kühlung, andere Typen sind mit Ventilator gekühlt.

x: Motor, ayak bağlantı yüzeyinin altında ise / x: If Motor is lower then foot mounting plane / x: Wenn motor ist niedriger den die Anschlußplatte

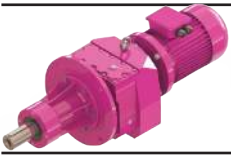

Ölçü Sayfaları Dimension Pages Abmessungsseiten



-Mil ucu çekirtme deliği DIN 332 sayfa 2 / Tapped center hole to DIN 332, sheet 2 / Zentrierung mit gewinde DIN 332, Blatt 2

**NVB775
NVB776**

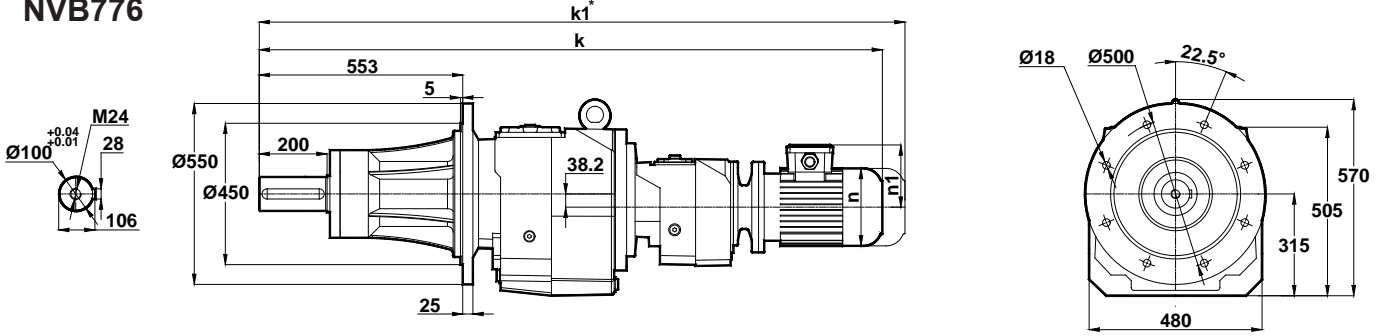

Motor Büyüklüğü / Motor Size / Motorbaugroße				
IEC	71/B5	80/B5 80/B14	90S/B5 90S/B14	90L/B5 90L/B14
k	1498	1518	1538	1563
k1	1618	1638	1663	1688
n / n1	138 / 111	156 / 118	176 / 126	176 / 126
m1 (B5)	160	200	200	200
m1 (B14)	-	120	140	140

Klemens Kutusu / Terminal Box / Klemmenkasten

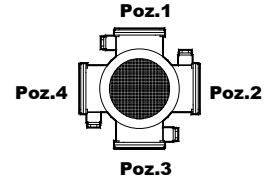

71-80-90

* " k1 " Ölçüsü frenli redüktörlere aittir. 63, 71 tip elektrik motorlu redüktörler soğutmasız, diğerleri soğutmalıdır.

Dimension " k1 " is for motors with brake. Gearboxes with 63 and 71 type electrical motors are not fan cooled, other types are fan cooled.

Maße " k1 " ist für Bremsenmotoren. Getrieben mit 63 und 71 typ Motoren sind ohne Kühlung, andere Typen sind mit Ventilator gekühlt.

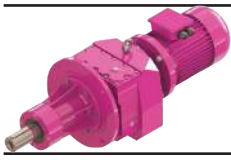

Ölçü Sayfaları Dimension Pages Abmessungsseiten



-Mil ucu çekirme deliği DIN 332 sayfa 2 / Tapped center hole to DIN 332, sheet 2 / Zentrierung mit gewinde DIN 332, Blatt 2

NVB872 NVB873

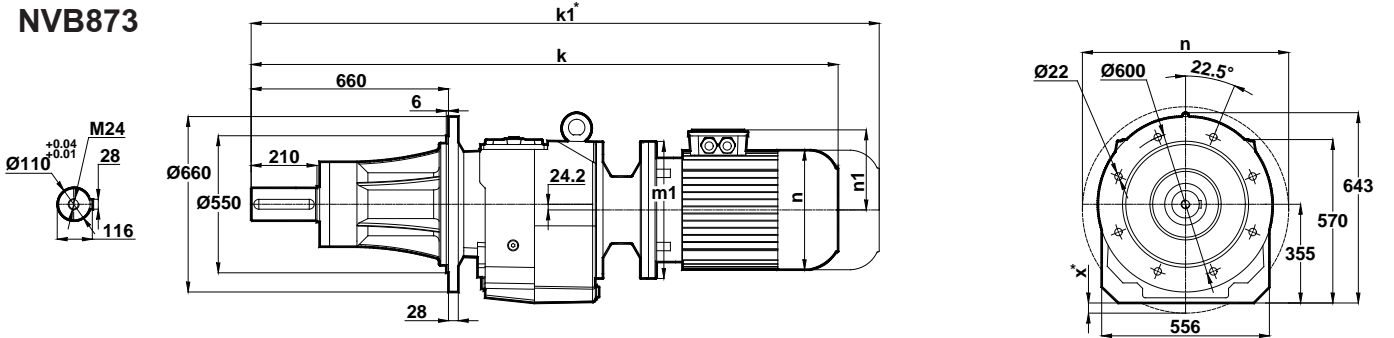

Motor Büyüklüğü / Motor Size / Motorbaugroße										
IEC	160M/B5	160L/B5	180M/B5	180L/B5	200L/B5	225S/B5	225M/B5	250M/B5	280S/B5	280M/B5
k	1863	1907	1920	1958	2010	2028	2053	2129	2191	2191
k1	2033	2077	2090	2128	2210	2218	2243	-	-	-
n / n1	310 / 225	310 / 225	348 / 241	348 / 241	390 / 275	434 / 285	434 / 285	480 / 322	544 / 350	544 / 350
m1 (B5)	350	350	350	350	400	450	450	550	550	550
m1 (B14)	-	-	-	-	-	-	-	-	-	-
x (B5)	-	-	-	-	-	-	-	-	-	-

Klemens Kutusu / Terminal Box / Klemmenkasten

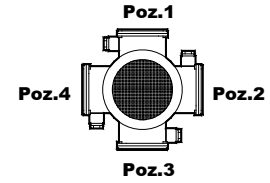

160-180-200-225-250-280

NVB874

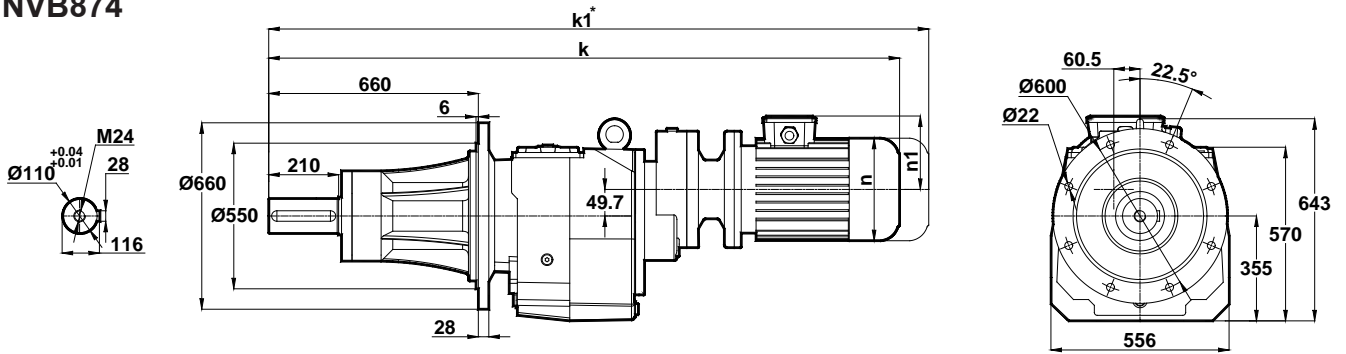

Motor Büyüklüğü / Motor Size / Motorbaugroße				
IEC	100L/B5	112M/B5	132S/B5 132S/B14	132M/B5 132M/B14
k	1662	1682	1747	1785
k1	1797	1817	1892	1930
n / n1	194 / 135	218 / 146	257 / 168	257 / 168
m1 (B5)	250	250	300	300
m1 (B14)	-	-	200	200

Klemens Kutusu / Terminal Box / Klemmenkasten

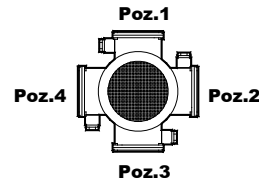

100-112-132

* " k1 " Ölçüsü frenli redüktörlere aittir. 63, 71 tip elektrik motorlu redüktörler soğutmasız, diğerleri soğutmalıdır.
Dimension " k1 " is for motors with brake. Gearboxes with 63 and 71 type electrical motors are not fan cooled, other types are fan cooled.
Maße " k1 " ist für Bremsenmotoren. Getrieben mit 63 und 71 typ Motoren sind ohne Kühlung, andere Typen sind mit Ventilator gekühlt.
x: Motor, ayak bağlantı yüzeyinin altında ise / x: If Motor is lower then foot mounting plane / x: Wenn motor ist niedriger den die Anschlußplatte

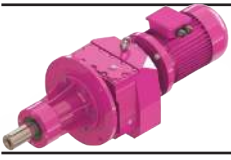

Ölçü Sayfaları Dimension Pages Abmessungsseiten



-Mil ucu çektirme deliği DIN 332 sayfa 2 / Tapped center hole to DIN 332, sheet 2 / Zentrierung mit gewinde DIN 332, Blatt 2

NVB875
NVB876

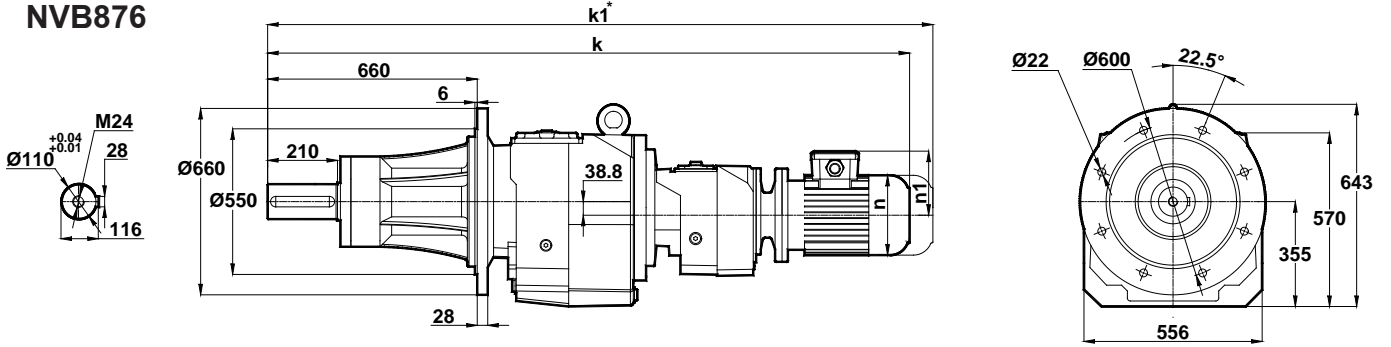

Motor Büyüklüğü / Motor Size / Motorbaugroße					
IEC	71/B5	80/B5 80/B14	90S/B5 90S/B14	90L/B5 90L/B14	100L/B5 100L/B14
k	1682	1702	1722	1747	1796
k1	1802	1822	1847	1872	1931
n / n1	138 / 111	156 / 118	176 / 126	176 / 126	194 / 135
m1 (B5)	160	200	200	200	250
m1 (B14)	-	120	140	140	160

Klemens Kutusu / Terminal Box / Klemmenkasten

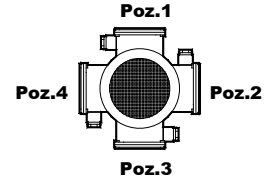

71-80-90-100

* "k1" Ölçüsü frenli redüktörlere aittir. 63, 71 tip elektrik motorlu redüktörler soğutmasız, diğerleri soğutmalıdır.
Dimension "k1" is for motors with brake. Gearboxes with 63 and 71 type electrical motors are not fan cooled, other types are fan cooled.
Maße "k1" ist für Bremsenmotoren. Getrieben mit 63 und 71 typ Motoren sind ohne Kühlung, andere Typen sind mit Ventilator gekühlt.

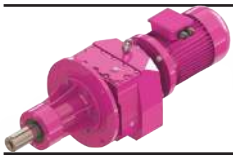

Ölçü Sayfaları Dimension Pages Abmessungsseiten



-Mil ucu çekirme deliği DIN 332 sayfa 2 / Tapped center hole to DIN 332, sheet 2 / Zentrierung mit gewinde DIN 332, Blatt 2

NVB972 NVB973

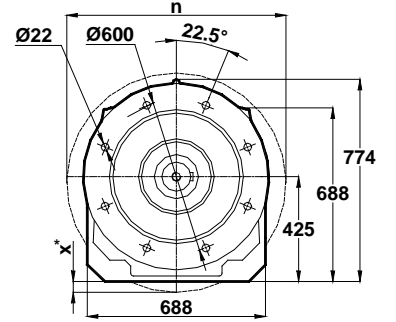
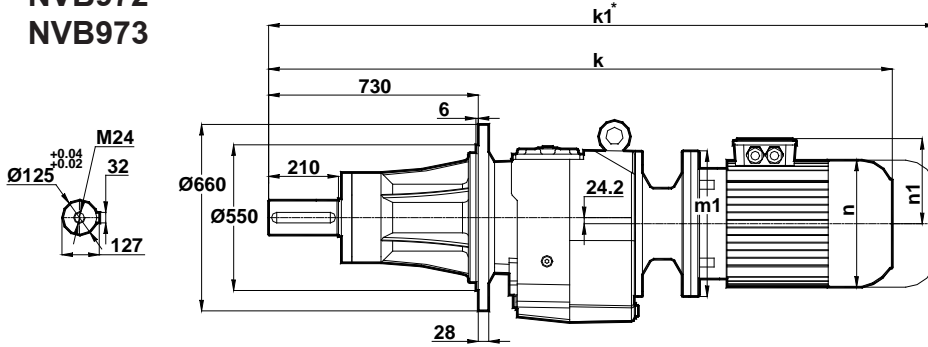

Motor Büyüklüğü / Motor Size / Motorbaugroße												
IEC	160M/B5	160L/B5	180M/B5	180L/B5	200L/B5	225S/B5	225M/B5	250M/B5	280S/B5	280M/B5	315S/4	315M/4
k	1921	1965	1978	2016	2092	2152	2177	2305	2367	2367	2579	2579
k1	2091	2135	2148	2186	2292	2342	2367	-	-	-	-	-
n / n1	310 / 225	310 / 225	348 / 241	348 / 241	390 / 275	434 / 285	434 / 285	480 / 322	544 / 350	544 / 350	614 / 510	614 / 510
m1 (B5)	350	350	350	350	400	450	450	550	550	550	660	660
m1 (B14)	-	-	-	-	-	-	-	-	-	-	-	-
x (B5)	-	-	-	-	-	-	-	-	-	-	-	-

Klemens Kutusu / Terminal Box / Klemmenkasten

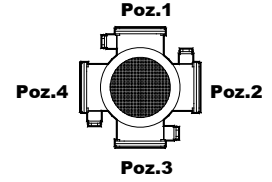

160-180-200-225-250-280-315

NVB974

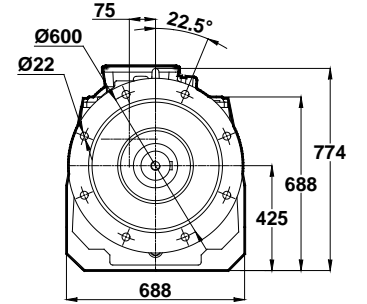
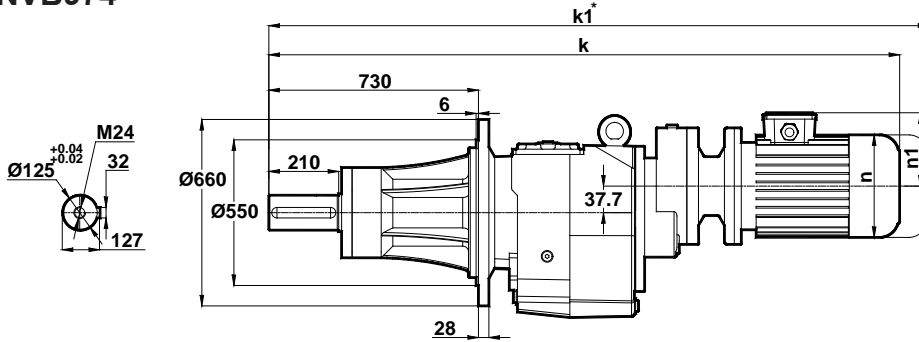

Motor Büyüklüğü / Motor Size / Motorbaugroße				
IEC	100L/B5	112M/B5	132S/B5 132S/B14	132M/B5 132M/B14
k	1835	1855	1914	1952
k1	1970	1990	2059	2097
n / n1	194 / 135	218 / 146	257 / 168	257 / 168
m1 (B5)	250	250	300	300
m1 (B14)	-	-	200	200

Klemens Kutusu / Terminal Box / Klemmenkasten

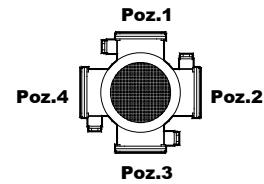

100-112-132

* "k1" Ölçüsü frenli redüktörlere aittir. 63, 71 tip elektrik motorlu redüktörler soğutmasız, diğerleri soğutmalıdır.
Dimension "k1" is for motors with brake. Gearboxes with 63 and 71 type electrical motors are not fan cooled, other types are fan cooled.
Maße "k1" ist für Bremsenmotoren. Getrieben mit 63 und 71 typ Motoren sind ohne Kühlung, andere Typen sind mit Ventilator gekühlt.
x: Motor, ayak bağlantı yüzeyinin altında ise / x: If Motor is lower than foot mounting plane / x: Wenn motor ist niedriger den die Anschlußplatte

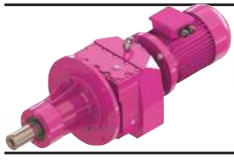

Ölçü Sayfaları Dimension Pages Abmessungsseiten



-Mil ucu çektirme deliği DIN 332 sayfa 2 / Tapped center hole to DIN 332, sheet 2 / Zentrierung mit gewinde DIN 332, Blatt 2

NVB975 NVB976

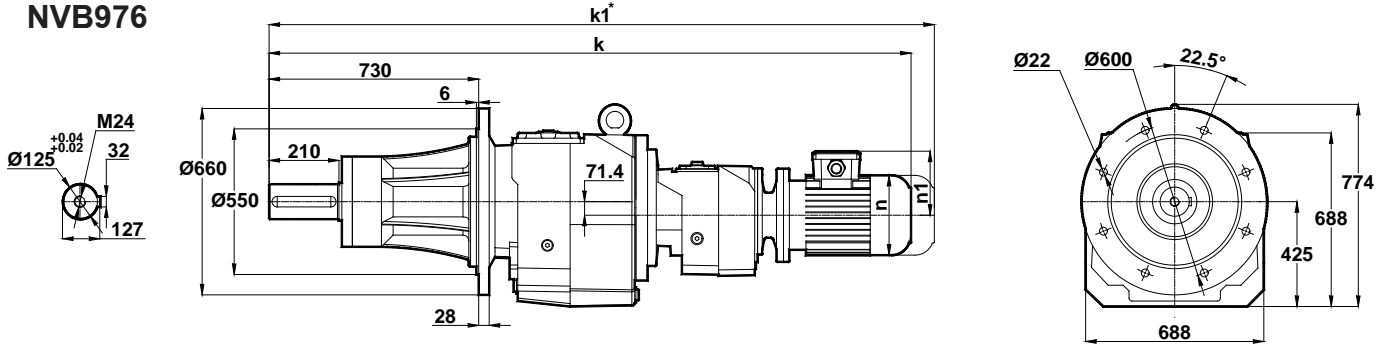

Motor Büyüklüğü / Motor Size / Motorbaugroße						
IEC	80/B5	90S/B5 90S/B14	90L/B5 90L/B14	100L/B5 100L/B14	112M/B5 112M/B14	132S/B5 132S/B14
k	1894	1914	1939	1990	2010	2072
k1	2014	2039	2064	2125	2145	2217
n / n1	156 / 118	176 / 126	176 / 126	194 / 135	218 / 146	218 / 146
m1 (B5)	200	200	200	250	250	300
m1 (B14)	-	140	140	160	160	200

Klemens Kutusu / Terminal Box / Klemmenkasten

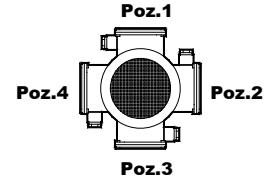

80-90-100-112-132

* "k1" Ölçüsü frenli redüktörlere aittir. 63, 71 tip elektrik motorlu redüktörler soğutmasız, diğerleri soğutmalıdır.

Dimension "k1" is for motors with brake. Gearboxes with 63 and 71 type electrical motors are not fan cooled, other types are fan cooled.
Maße "k1" ist für Bremsenmotoren. Getrieben mit 63 und 71 typ Motoren sind ohne Kühlung, andere Typen sind mit Ventilator gekühlt.



Güç ve Devir Tabloları

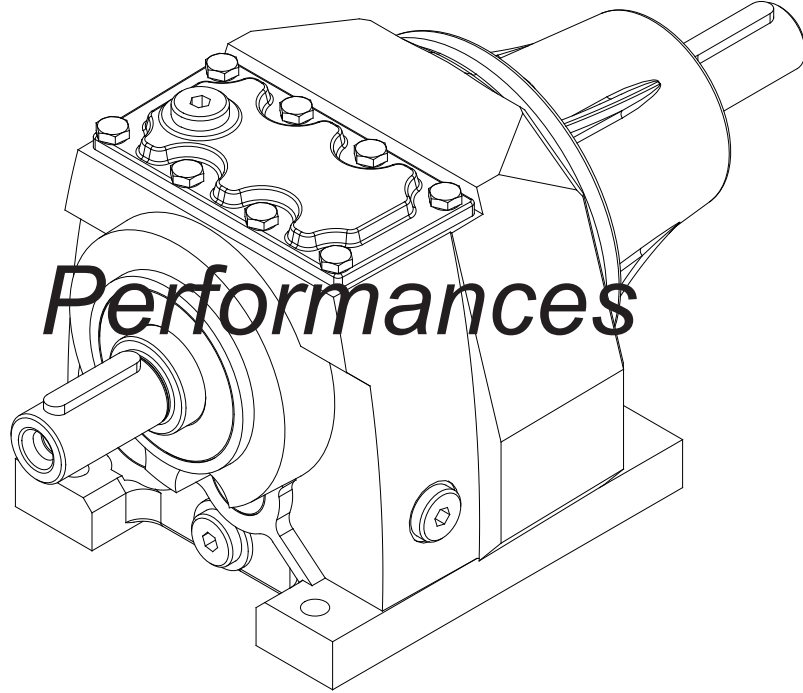

Leistung und Drehzahlübersicht



Motorsuz Güç Devir Sayfaları

Gear Units Performance Tables

Leistung und Drehzahlübersicht von Getriebe

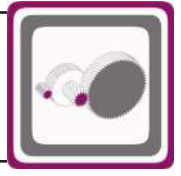

Anma Momenti <i>Nominal Torques</i> Nenn-drehmomente Ma [Nm] (n1=1400rpm)	Çevrim Oranı <i>Ratio</i> Übersetzung i	Çıkış Devri <i>Output Speeds</i> Abtriebs-drehzahlen n2 [r.p.m] (n1=1400rpm)	Tipi <i>Type</i> Typ	Pe= Nominal Güç [kW] (Servis Faktörü fs=1,0 için) <i>Pe= Nominal Power [kW] (For Service Factor fs=1,0)</i> Pe= NennLeistung [kW] (Bei Betriebsfaktor fs=1,0)						Güv. Rad.Yük Çıkış <i>Per.O.Loads (Output)</i>	Güv.Rad.Yük Giriş <i>Per.O.Loads (Input)</i>	Ağırlık <i>Weight</i> Gewicht [kg]	Ölçü Sayfası <i>Dim. Page</i> Maße Seite	Fiyat Kodu <i>Price Ref.</i> Preis No.
				Giriş devri[d/d] / Input speed[rpm] / Antriebsdrehzahl[upm]										
				n1=2800	n1=1400	n1=900	n1=750	n1=450	n1=350	Fqam [N] (n1=1400rpm)	Fqem [N] (n1=1400rpm)			
53	3,62	387	MT002	3,52	2,23	1,68	1,49	1,06	0,87	380	-	11	330	MT001
55	3,90	359	NT002	3,42	2,15	1,61	1,43	1,02	0,81	371	-	12		NT001
58	4,56	307		3,07	1,94	1,45	1,30	0,89	0,69	389	-			
64	5,57	251		2,78	1,75	1,31	1,16	0,73	0,57	591	-			
66	6,00	233		2,63	1,68	1,25	1,11	0,68	0,53	597	-			
69	6,91	203		2,38	1,53	1,14	0,98	0,59	0,46	712	-			
71	7,45	188		2,29	1,46	1,09	0,91	0,55	0,42	724	-			
72	7,84	179		2,21	1,40	1,03	0,86	0,52	0,40	795	-			
74	8,45	166		2,09	1,34	0,96	0,80	0,48	0,37	811	-			
74	8,70	161		2,07	1,31	0,93	0,78	0,47	0,36	781	-			
78	9,87	142		1,89	1,21	0,82	0,68	0,41	0,32	853	-			
65	11,14	126		1,46	0,90	0,70	0,61	0,37	0,29	1275	-			
80	13,61	103	MT003	1,39	0,92	0,61	0,51	0,30	0,24	601	435	12	330	MT002
82	14,67	95	NT003	1,33	0,87	0,56	0,47	0,28	0,22	617	438	13		NT002
82	16,89	83		1,38	0,76	0,49	0,41	0,25	0,19	859	562			
82	18,20	77		1,33	0,70	0,45	0,38	0,23	0,18	937	571			
82	19,17	73		1,29	0,67	0,43	0,36	0,22	0,17	1054	599			
82	20,66	68		1,23	0,62	0,39	0,33	0,20	0,16	1136	607			
82	21,26	66		1,20	0,61	0,38	0,33	0,20	0,15	1107	587			
82	24,13	58		1,06	0,53	0,34	0,29	0,17	0,13	1313	621			
82	28,38	49		0,90	0,45	0,29	0,24	0,15	0,11	1508	660			
82	32,02	44		0,74	0,40	0,26	0,22	0,13	0,10	1689	684			
82	40,04	35		0,65	0,32	0,21	0,17	0,11	0,08	1959	680			
82	45,18	31		0,58	0,29	0,19	0,16	0,09	0,07	2159	702			
70	3,94	355	MT102	4,22	2,70	1,99	1,76	1,25	1,07	1058	-	13	331	MT003
75	4,57	306	NT102	3,98	2,50	1,83	1,70	1,19	1,01	1103	-	14		NT003
80	5,01	279		3,62	2,43	1,76	1,55	1,13	0,96	1120	-			
80	5,47	256		3,60	2,23	1,71	1,50	1,08	0,91	1168	-			
85	6,48	216		3,28	2,00	1,52	1,33	0,95	0,77	1233	-			
90	6,93	202		3,07	1,98	1,42	1,30	0,93	0,72	1242	-			
90	8,01	175		2,66	1,72	1,29	1,13	0,80	0,67	1391	553			
95	9,29	151		2,46	1,57	1,17	1,06	0,75	0,58	1459	564			
100	10,18	137		2,24	1,50	1,11	0,97	0,68	0,53	1492	550			
100	11,12	126		2,20	1,38	1,07	0,93	0,62	0,49	1554	633			
105	13,15	106		1,97	1,23	0,94	0,85	0,53	0,41	1648	631			
110	14,08	99		1,85	1,20	0,91	0,79	0,49	0,38	1671	569			
115	15,95	88		1,73	1,11	0,84	0,73	0,44	0,34	1740	509			
110	17,33	81	MT103	1,52	0,99	0,76	0,68	0,41	0,32	1764	830	14	331	MT004
120	20,51	68	NT103	1,36	0,91	0,69	0,57	0,35	0,27	1842	817	15		NT004
120	21,96	64		1,34	0,85	0,64	0,54	0,32	0,25	1903	825			
130	24,86	56		1,25	0,82	0,57	0,48	0,29	0,22	1951	804			
140	29,40	48		1,16	0,75	0,48	0,40	0,24	0,19	2139	937			
140	32,25	43		1,06	0,68	0,44	0,37	0,22	0,17	2231	948			
140	35,21	40		1,02	0,62	0,40	0,34	0,20	0,16	2322	956			
140	41,66	34		0,90	0,53	0,34	0,29	0,17	0,13	2503	966			
140	44,60	31		0,88	0,50	0,32	0,27	0,16	0,12	2579	970			
140	50,51	28		0,81	0,44	0,28	0,24	0,14	0,11	2723	974			
110	3,38	414	MT172	7,57	4,92	3,90	3,37	2,46	2,03	609	-	15	332	MT005
120	4,09	343	NT172	7,38	4,45	3,59	3,19	2,28	1,87	591	-	16		NT005
130	4,78	293		6,94	4,12	3,48	3,07	2,05	1,60	772	-			
135	5,78	242		6,28	3,55	3,22	2,83	1,70	1,33	888	-			
145	6,60	212		5,73	3,34	2,97	2,48	1,49	1,16	856	-			
160	7,60	184		5,38	3,21	2,58	2,15	1,30	1,01	746	-			
165	8,94	157		4,75	2,81	2,20	1,83	1,10	0,86	861	-			
170	9,53	147		4,62	2,72	2,06	1,72	1,03	0,81	852	-			
180	11,08	126		3,98	2,48	1,78	1,48	0,89	0,69	1257	-			
190	12,66	111		3,60	2,29	1,56	1,30	0,78	0,61	1284	-			



Motorsuz Güç Devir Sayfaları

Gear Units Performance Tables

Leistung und Drehzahlübersicht von Getriebe

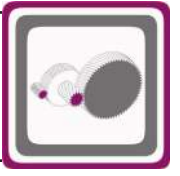

Anma Momenti <i>Nominal Torques</i> Nenn-drehmomente Ma [Nm] (n1=1400rpm)	Çevrim Oranı <i>Ratio</i> Übersetzung i	Çıkış Devri <i>Output Speeds</i> Abtriebs-drehzahlen n2 [r.p.m] (n1=1400rpm)	Tipi <i>Type</i> Typ	Pe= Nominal Güç [kW] (Servis Faktörü fs=1,0 için) <i>Pe= Nominal Power [kW] (For Service Factor fs=1,0)</i> Pe= NennLeistung [kW] (Bei Betriebsfaktor fs=1,0)						Güv. Rad.Yük Çıkış <i>Per.O.Loads (Output)</i>	Güv.Rad.Yük Giriş <i>Per.O.Loads (Input)</i>	Ağırlık <i>Weight</i> Gewicht [kg]	Ölçü Sayfası <i>Dim. Page</i> Maße Seite	Fiyat Kodu <i>Price Ref.</i> Preis No.
				Giriş devri[d/d] / Input speed[rpm] / Antriebsdrehzahl[upm]										
				n1=2800	n1=1400	n1=900	n1=750	n1=450	n1=350					
195	14,57	96	MT172	3,24	2,05	1,35	1,13	0,68	0,53	1415	-	15	332	MT005
200	17,14	82	NT172	2,85	1,79	1,15	0,96	0,58	0,45	1591	-	16		NT005
200	18,28	77		2,76	1,68	1,08	0,90	0,54	0,42	1698	-			
200	20,92	67		2,48	1,47	0,95	0,79	0,47	0,37	1930	-			
200	26,10	54	MT173	1,48	1,19	0,77	0,64	0,39	0,30	2857	827	16	332	MT006
200	30,26	46	NT173	1,33	1,03	0,67	0,56	0,33	0,26	3057	847	17		NT006
200	36,24	39		1,24	0,86	0,56	0,42	0,28	0,22	3314	873			
200	42,87	33		1,13	0,73	0,47	0,39	0,24	0,18	3568	888			
200	45,90	31		1,16	0,69	0,44	0,37	0,22	0,17	3675	894			
200	49,81	28		1,10	0,63	0,41	0,34	0,20	0,16	3807	989			
200	57,76	24		0,98	0,55	0,35	0,29	0,18	0,14	4055	999			
200	69,16	20		0,91	0,46	0,30	0,25	0,15	0,12	4373	1013			
200	81,82	17		0,77	0,39	0,25	0,21	0,13	0,10	4689	1021			
200	87,60	16		0,72	0,36	0,23	0,20	0,12	0,09	4822	1024			
200	99,21	14		0,64	0,32	0,21	0,17	0,10	0,08	5072	1027			
125	3,50	400	MT202	8,62	5,41	4,19	3,61	2,59	2,24	2285	-	20	333	MT007
145	4,20	333	NT202	8,27	5,24	3,85	3,40	2,46	2,10	2128	-	22		NT007
150	4,50	311		8,05	5,05	3,80	3,35	2,40	2,04	2140	-			
160	5,08	276		7,45	4,79	3,57	3,22	2,28	1,93	2131	-			
175	5,80	241		7,05	4,59	3,38	3,04	2,17	1,82	2039	-			
185	7,04	199		6,23	3,99	2,99	2,67	1,92	1,52	2954	657			
200	8,40	167		5,59	3,62	2,69	2,39	1,64	1,28	3055	670			
210	10,07	139		4,97	3,18	2,39	2,12	1,37	1,07	3297	770			
215	10,81	130		4,77	3,03	2,27	2,01	1,28	0,99	3374	776			
225	12,18	115		4,49	2,82	2,10	1,85	1,14	0,88	3486	775			
235	13,92	101		4,05	2,58	1,95	1,65	0,99	0,77	3650	778			
240	14,86	94		3,89	2,47	1,86	1,55	0,93	0,72	3734	768			
245	16,03	87		3,71	2,34	1,72	1,44	0,87	0,67	3852	780			
260	18,85	74		3,32	2,11	1,47	1,22	0,74	0,57	4038	714			
260	20,10	70		3,19	1,98	1,38	1,15	0,69	0,54	4240	773			
280	23,01	61		2,92	1,87	1,20	1,00	0,60	0,47	4271	608			
270	23,23	60	MT203	2,79	1,81	1,21	1,01	0,61	0,47	3431	1163	21	333	MT008
275	24,77	57	NT203	2,68	1,73	1,14	0,95	0,57	0,44	3525	1162	23		NT008
280	28,35	49		2,46	1,54	0,99	0,83	0,50	0,39	3876	1172			
280	36,02	39		1,93	1,21	0,78	0,65	0,39	0,31	5354	1504			
280	41,16	34		1,77	1,06	0,69	0,57	0,34	0,27	5657	1519			
280	43,94	32		1,69	0,99	0,64	0,54	0,32	0,25	5810	1526			
280	47,39	30		1,61	0,92	0,60	0,50	0,30	0,26	5992	1533			
280	55,74	25		1,43	0,79	0,51	0,42	0,26	0,22	6397	1547			
280	59,43	24		1,37	0,74	0,48	0,40	0,27	0,21	6563	1552			
280	68,03	21		1,27	0,65	0,42	0,35	0,23	0,18	6926	1561			
195	3,16	443	MT272	14,73	9,31	6,93	6,17	4,41	3,74	620	-	25	334	MT009
205	3,69	380	NT272	13,45	8,40	6,34	5,62	3,98	3,41	659	-	27		NT009
230	4,53	309		11,97	7,69	5,60	5,04	3,57	3,04	924	-			
265	5,28	265		11,13	7,60	5,55	5,01	3,34	2,82	543	-			
330	6,21	225		13,60	8,05	5,90	5,38	3,56	2,77	-	-			
360	8,71	161		9,88	6,27	4,49	4,17	2,54	1,98	550	-			
375	10,16	138		8,77	5,60	4,14	3,62	2,18	1,69	646	-			
390	11,95	117		7,85	4,96	3,69	3,08	1,85	1,44	779	-			
410	14,21	99		6,93	4,39	3,11	2,59	1,56	1,21	878	-			
425	16,07	87		6,42	4,03	2,75	2,30	1,38	1,07	951	-			
445	18,33	76		5,80	3,71	2,42	2,02	1,21	0,94	977	-			
450	21,43	65		5,18	3,21	2,07	1,72	1,04	0,81	1341	-			
450	25,89	54		4,59	2,66	1,71	1,43	0,86	0,67	1914	-			
435	19,00	74	MT273	5,41	3,54	2,36	1,97	1,19	0,93	288	326	26	334	MT010
435	25,55	55	NT273	4,02	2,63	1,76	1,47	0,88	0,69	2121	1297	28		NT010



Motorsuz Güç Devir Sayfaları

Gear Units Performance Tables

Leistung und Drehzahlübersicht von Getriebe

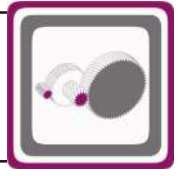

Anma Momenti <i>Nominal Torques</i> Nenn-drehmomente Ma [Nm] (n1=1400rpm)	Çevrim Oranı <i>Ratio</i> Übersetzung i	Çıkış Devri <i>Output Speeds</i> Abtriebs-drehzahlen n2 [r.p.m] (n1=1400rpm)	Tipi <i>Type</i> Typ	Pe= Nominal Güç [kW] (Servis Faktörü fs=1,0 için) <i>Pe= Nominal Power [kW] (For Service Factor fs=1,0)</i> Pe= NennLeistung [kW] (Bei Betriebsfaktor fs=1,0)						Güv. Rad.Yük Çıkış <i>Per.O.Loads (Output)</i> Zul.Querkräfte (Abtrieb) Fqam [N] (n1=1400rpm)	Güv.Rad.Yük Giriş <i>Per.O.Loads (Input)</i> Zul.Querkräfte (Antrieb) Fqem [N] (n1=1400rpm)	Ağırlık <i>Weight</i> Gewicht [kg]	Ölçü Sayfası <i>Dim. Page</i> Maße Seite	Fiyat Kodu <i>Price Ref.</i> Preis No.
				Giriş devri[d/d] / Input speed[rpm] / Antriebsdrehzahl[upm]										
				n1=2800	n1=1400	n1=900	n1=750	n1=450	n1=350					
450	30,48	46	MT273	3,58	2,28	1,47	1,23	0,74	0,58	2438	1325	26	334	MT010
450	36,55	38	NT273	3,16	1,91	1,23	1,03	0,62	0,48	3055	1364	28		NT010
450	42,41	33		2,90	1,65	1,06	0,89	0,53	0,42	3590	1501			
450	50,59	28		2,59	1,38	0,89	0,75	0,45	0,35	4259	1529			
450	60,66	23		2,30	1,16	0,75	0,62	0,38	0,29	4990	1553			
450	73,35	19		1,91	0,96	0,62	0,52	0,31	0,27	5804	1574			
450	83,83	17		1,67	0,84	0,54	0,45	0,27	0,24	6408	1586			
450	96,52	15		1,46	0,73	0,47	0,39	0,26	0,21	6700	1597			
450	113,52	12		1,24	0,62	0,40	0,34	0,22	0,17	6700	1608			
450	121,03	12		1,17	0,59	0,38	0,32	0,21	0,16	6700	1612			
450	138,55	10		1,02	0,51	0,33	0,28	0,18	0,14	6700	1619			
450	149,02	9,4	MT275	0,99	0,49	0,32	0,27	0,18	0,14	6700	694	39	335	MT011
450	180,21	7,8	NT275	0,82	0,41	0,26	0,24	0,15	0,11	6700	727	41		NT011
450	205,95	6,8		0,72	0,36	0,26	0,21	0,13	0,10	6700	746			
450	215,91	6,5		0,68	0,34	0,24	0,20	0,12	0,09	6700	753			
450	252,20	5,6		0,59	0,29	0,21	0,17	0,10	0,08	6700	797			
450	332,52	4,2		0,49	0,25	0,18	0,15	0,09	0,07	6700	799			
450	358,33	3,9		0,46	0,23	0,16	0,14	0,08	0,06	6700	804			
450	418,57	3,3		0,39	0,20	0,14	0,12	0,07	0,05	6700	816			
450	499,32	2,8		0,33	0,16	0,12	0,10	0,06	0,05	6700	826			
450	598,70	2,3		0,28	0,14	0,10	0,08	0,05	0,04	6700	836			
450	724,01	1,9		0,25	0,11	0,08	0,07	0,04	0,03	6700	841			
450	827,44	1,7		0,22	0,10	0,07	0,06	0,04	0,03	6700	846			
450	952,64	1,5		0,19	0,09	0,06	0,05	0,03	0,02	6700	851			
450	1120,49	1,2		0,16	0,07	0,05	0,04	0,03	0,02	6700	853			
450	1194,61	1,2		0,15	0,07	0,05	0,04	0,02	0,02	6700	853			
450	1463,49	0,96	MT276	0,13	0,06	0,04	0,03	0,02	0,02	6700	869	40	335	MT012
450	1769,80	0,79	NT276	0,11	0,05	0,03	0,03	0,02	0,01	6700	858	42		NT012
450	2022,63	0,69		0,09	0,04	0,03	0,02	0,01	0,01	6700	862			
450	2328,68	0,60		0,08	0,04	0,03	0,02	0,01	0,01	6700	864			
450	2738,97	0,51		0,07	0,03	0,02	0,02	0,01	0,01	6700	858			
450	2920,17	0,48		0,06	0,03	0,02	0,02	0,01	0,01	6700	864			
220	3,15	444	MT282	16,25	10,56	7,74	6,72	4,98	4,24	2357	-	37	336	MT013
240	3,64	385	NT282	15,74	9,99	7,51	6,72	4,58	3,99	2305	-	39		NT013
260	4,20	333		15,06	9,37	7,44	6,40	4,55	3,82	2266	-			
280	4,62	303		15,02	9,18	7,40	6,35	4,36	3,64	2125	-			
320	5,35	262		14,67	9,07	7,31	6,25	4,32	3,72	1757	-			
360	6,25	224		14,02	8,74	6,58	5,88	4,17	3,55	1430	-			
370	7,21	194		12,15	7,79	5,83	5,21	3,75	3,13	2610	-			
390	8,33	168		10,90	7,11	5,29	4,71	3,31	2,76	2710	-			
400	9,61	146		9,75	6,32	4,69	4,16	2,97	2,39	2985	160			
410	10,57	132		9,16	5,90	4,36	3,87	2,79	2,18	3124	215			
420	12,24	114		8,42	5,22	3,93	3,48	2,41	1,88	3448	347			
440	14,31	98		7,43	4,69	3,57	3,15	2,07	1,61	3669	359			
470	16,91	83		6,65	4,25	3,14	2,77	1,75	1,36	3804	267			
480	19,06	73		6,07	3,85	2,90	2,59	1,56	1,21	4101	310			
500	21,66	65		5,63	3,54	2,64	2,28	1,37	1,07	4294	252			
530	25,23	55		5,08	3,22	2,35	1,96	1,18	0,92	4457	122			
560	30,37	46		4,43	2,83	1,95	1,63	0,98	0,76	4802	-			
270	18,33	76	MT283	3,52	2,28	1,80	1,64	1,18	1,03	6936	1848	38	336	MT014
290	20,25	69	NT283	3,34	2,22	1,73	1,57	1,14	0,97	7197	1837	40		NT014
320	23,63	59		3,13	2,10	1,57	1,41	1,04	0,88	7612	1822			
340	27,80	50		2,78	1,90	1,44	1,30	0,94	0,81	5730	1821			
480	30,82	45		3,69	2,41	1,85	1,63	0,98	0,76	5615	1883			
515	35,98	39		3,34	2,22	1,67	1,39	0,84	0,66	5876	1886			
550	41,96	33		3,16	2,03	1,43	1,20	0,72	0,56	6155	1893			
570	46,37	30		2,93	1,91	1,30	1,08	0,65	0,51	6358	1896			



Motorsuz Güç Devir Sayfaları

Gear Units Performance Tables

Leistung und Drehzahlübersicht von Getriebe

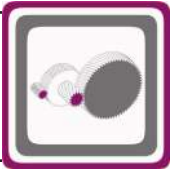

Anma Momenti Nominal Torques Nenn-drehmomente Ma [Nm] (n1=1400rpm)	Çevrim Oranı Ratio Übersetzung i	Çıkış Devri Output Speeds Abtriebs-drehzahlen n2 [r.p.m] (n1=1400rpm)	Tipi Type Typ	Pe= Nominal Güç [kW] (Servis Faktörü fs=1,0 için) Pe= Nominal Power [kW] (For Service Factor fs=1,0) Pe= NennLeistung [kW] (Bei Betriebsfaktor fs=1,0)						Güv. Rad.Yük Çıkış Per.O.Loads (Output) Zul.Querkräfte (Abtrieb) Fqam [N] (n1=1400rpm)	Güv.Rad.Yük Giriş Per.O.Loads (Input) Zul.Querkräfte (Antrieb) Fqem [N] (n1=1400rpm)	Ağırlık Weight Gewicht [kg]	Ölçü Sayfası Dim. Page Maße Seite	Fiyat Kodu Price Ref. Preis No.
				Giriş devri[d/d] / Input speed[rpm] / Antriebsdrehzahl[upm]										
				n1=2800	n1=1400	n1=900	n1=750	n1=450	n1=350					
600	54,12	26	MT283	2,63	1,73	1,11	0,93	0,56	0,44	6694	1900	38	336	MT014
600	63,65	22	NT283	2,39	1,47	0,95	0,79	0,48	0,37	7195	1920	40		NT014
600	75,68	18		2,18	1,24	0,80	0,67	0,40	0,31	7758	1939			
600	85,60	16		2,01	1,10	0,71	0,59	0,36	0,28	8180	1950			
600	97,62	14		1,86	0,97	0,62	0,52	0,31	0,27	8649	1961			
600	114,14	12		1,65	0,83	0,54	0,45	0,27	0,23	9150	1972			
600	137,91	10		1,37	0,69	0,45	0,37	0,25	0,19	9150	1982			
600	158,52	8,8	MT284	1,21	0,60	0,39	0,32	0,22	0,17	9150	1602	39	337	MT015
600	175,17	8,0	NT284	1,09	0,55	0,35	0,29	0,20	0,15	9150	1625	41		NT015
600	204,44	6,8		0,94	0,47	0,30	0,25	0,17	0,13	9150	1656			
600	240,47	5,8		0,80	0,40	0,26	0,24	0,14	0,11	9150	1684			
600	285,89	4,9		0,67	0,34	0,24	0,20	0,12	0,09	9150	1709			
600	323,39	4,3		0,60	0,30	0,21	0,18	0,11	0,08	9150	1725			
600	368,77	3,8		0,52	0,26	0,19	0,16	0,09	0,07	9150	1739			
600	431,18	3,2		0,50	0,25	0,18	0,15	0,09	0,07	9150	1800			
600	376,94	3,7	MT285	0,52	0,26	0,19	0,16	0,09	0,07	9150	1066	58	338	MT016
600	443,37	3,2	NT285	0,50	0,25	0,18	0,15	0,09	0,07	9150	1082	60		NT016
600	491,50	2,8		0,45	0,22	0,16	0,13	0,08	0,06	9150	1091			
600	573,81	2,4		0,38	0,19	0,14	0,11	0,07	0,05	9150	1102			
600	669,25	2,1		0,33	0,16	0,12	0,10	0,06	0,05	9150	1112			
600	739,53	1,9		0,30	0,15	0,11	0,09	0,05	0,04	9150	1117			
600	863,11	1,6		0,25	0,13	0,09	0,08	0,05	0,04	9150	1125			
600	1015,21	1,4		0,24	0,11	0,08	0,06	0,04	0,03	9150	1132			
600	1206,98	1,2		0,20	0,09	0,07	0,05	0,03	0,03	9150	1138			
600	1365,28	1,0		0,18	0,08	0,06	0,05	0,03	0,02	9150	1142			
600	1817,07	0,77	MT286	0,14	0,06	0,04	0,04	0,02	0,02	9150	1149	59	338	MT017
600	2119,30	0,66	NT286	0,12	0,05	0,04	0,03	0,02	0,01	9150	1152	61		NT017
600	2341,83	0,60		0,11	0,05	0,03	0,03	0,02	0,01	9150	1154			
600	2733,17	0,51		0,09	0,04	0,03	0,02	0,01	0,01	9150	1156			
600	3214,82	0,44		0,08	0,04	0,03	0,02	0,01	0,01	9150	1158			
385	3,28	427	MT372	27,93	17,70	13,20	11,76	8,35	7,08	975	-	45	339	MT018
410	3,74	374	NT372	26,10	16,54	12,49	11,07	7,91	6,67	879	-	48		NT018
445	4,29	326		24,53	15,67	11,69	10,33	7,41	6,26	633	-			
475	4,96	282		22,77	14,49	10,82	9,61	6,87	5,81	518	-			
510	5,23	268		23,03	14,75	11,00	9,80	6,93	5,91	1064	-			
530	5,97	235		21,21	13,45	10,14	9,01	6,41	5,25	1160	-			
560	6,84	205		18,95	12,40	9,28	8,22	5,88	4,58	1131	-			
560	8,25	170		16,10	10,29	7,70	6,82	4,88	3,80	2471	-			
590	9,41	149		14,76	9,51	7,07	6,24	4,28	3,33	2511	-			
620	10,80	130		13,73	8,72	6,44	5,75	3,73	2,91	2594	-			
650	12,48	112		12,38	7,93	5,94	5,25	3,24	2,52	2731	-			
670	13,53	103		11,86	7,53	5,58	4,96	2,98	2,32	2772	-			
710	16,20	86		10,48	6,68	4,97	4,15	2,49	1,94	2965	-			
740	18,45	76		9,71	6,12	4,37	3,65	2,19	1,71	3118	-			
770	20,62	68		8,99	5,70	3,91	3,26	1,96	1,53	3205	-			
805	23,33	60		8,22	5,27	3,46	2,89	1,74	1,35	3300	-			
650	18,68	75	MT373	8,33	5,35	3,99	3,55	2,19	1,71	5079	1113	47	339	MT019
650	20,64	68	NT373	7,55	4,85	3,71	3,30	1,99	1,55	5333	1278	50		NT019
650	21,65	65		7,20	4,62	3,58	3,14	1,90	1,48	5601	1576			
710	25,27	55		6,54	4,33	3,23	2,70	1,63	1,27	5809	1571			
750	29,47	47		5,92	3,92	2,77	2,31	1,39	1,09	6105	1590			
780	35,25	40		5,23	3,42	2,32	1,94	1,17	0,91	6536	1756			
820	41,16	34		4,67	3,09	1,99	1,67	1,00	0,78	6887	1771			
820	48,00	29		4,11	2,65	1,71	1,43	0,86	0,67	7400	1810			
820	53,04	26		3,95	2,40	1,55	1,29	0,78	0,61	7747	1830			
820	61,91	23		3,40	2,06	1,33	1,11	0,67	0,52	8307	1856			



Motorsuz Güç Devir Sayfaları

Gear Units Performance Tables

Leistung und Drehzahlübersicht von Getriebe



Anma Momenti <i>Nominal Torques</i> Nenn-drehmomente Ma [Nm] (n1=1400rpm)	Çevrim Oranı <i>Ratio</i> Übersetzung i	Çıkış Devri <i>Output Speeds</i> Abtriebs-drehzahlen n2 [r.p.m] (n1=1400rpm)	Tipi <i>Type</i> Typ	Pe= Nominal Güç [kW] (Servis Faktörü fs=1,0 için) <i>Pe= Nominal Power [kW] (For Service Factor fs=1,0)</i> Pe= NennLeistung [kW] (Bei Betriebsfaktor fs=1,0)						Güv. Rad.Yük Çıkış <i>Per.O.Loads (Output)</i> Zul.Querkräfte (Abtrieb) Fqam [N] (n1=1400rpm)	Güv.Rad.Yük Giriş <i>Per.O.Loads (Input)</i> Zul.Querkräfte (Antrieb) Fqem [N] (n1=1400rpm)	Ağırlık <i>Weight</i> Gewicht [kg]	Ölçü Sayfası <i>Dim. Page</i> Maße Seite	Fiyat Kodu <i>Price Ref.</i> Preis No.
				Giriş devri[d/d] / Input speed[rpm] / Antriebsdrehzahl[upm]										
				n1=2800	n1=1400	n1=900	n1=750	n1=450	n1=350					
820	72,81	19	MT373	3,04	1,76	1,13	0,95	0,57	0,44	8927	1881	47	339	MT019
820	86,57	16	NT373	2,73	1,48	0,96	0,80	0,48	0,37	9627	1902	50		NT019
820	97,92	14		2,52	1,31	0,85	0,71	0,43	0,33	10150	1916			
820	111,67	13		2,30	1,16	0,75	0,62	0,37	0,29	10732	1928			
820	138,72	10		1,86	0,93	0,60	0,50	0,30	0,26	11600	1945			
820	157,76	8,9		1,64	0,82	0,53	0,44	0,27	0,23	11600	1954			
820	181,34	7,7	MT374	1,44	0,72	0,46	0,39	0,26	0,20	11600	757	57	340	MT020
820	200,38	7,0	NT374	1,31	0,65	0,42	0,35	0,23	0,18	11600	897	60		NT020
820	233,86	6,0		1,12	0,56	0,36	0,30	0,20	0,16	11600	1620			
820	275,08	5,1		0,95	0,48	0,31	0,26	0,17	0,13	11600	1653			
820	327,04	4,3		0,80	0,40	0,26	0,24	0,14	0,11	11600	1683			
820	369,93	3,8		0,71	0,36	0,25	0,21	0,13	0,10	11600	1702			
820	421,85	3,3		0,62	0,31	0,22	0,19	0,11	0,09	11600	1719			
820	524,07	2,7		0,50	0,25	0,18	0,15	0,09	0,07	11600	1743			
820	488,82	2,9	MT375	0,55	0,28	0,20	0,16	0,10	0,08	11600	1090	63	341	MT021
820	533,70	2,6	NT375	0,51	0,25	0,18	0,15	0,09	0,07	11600	1093	66		NT021
820	631,45	2,2		0,47	0,24	0,17	0,14	0,08	0,07	11600	1097			
820	676,02	2,1		0,44	0,22	0,16	0,13	0,08	0,06	11600	1099			
820	765,58	1,8		0,39	0,20	0,14	0,12	0,07	0,05	11600	1101			
820	845,97	1,7		0,36	0,18	0,13	0,11	0,06	0,05	11600	1107			
820	987,33	1,4		0,30	0,15	0,11	0,09	0,05	0,04	11600	1116			
820	1161,33	1,2		0,26	0,13	0,09	0,08	0,05	0,04	11600	1124			
820	1380,71	1,0		0,24	0,11	0,08	0,06	0,04	0,03	11600	1132			
820	1561,78	0,90		0,21	0,10	0,07	0,06	0,03	0,03	11600	1136			
820	1690,05	0,83	MT376	0,20	0,09	0,06	0,05	0,03	0,03	11600	1146	65	341	MT022
820	1999,59	0,70	NT376	0,17	0,08	0,05	0,05	0,03	0,02	11600	1147	68		NT022
820	2140,73	0,65		0,16	0,07	0,05	0,04	0,03	0,02	11600	1148			
820	2424,34	0,58		0,14	0,06	0,05	0,04	0,02	0,02	11600	1148			
820	2678,89	0,52		0,13	0,06	0,04	0,03	0,02	0,02	11600	1150			
820	3126,56	0,45		0,11	0,05	0,04	0,03	0,02	0,01	11600	1153			
820	3677,53	0,38		0,09	0,04	0,03	0,02	0,01	0,01	11600	1156			
820	4372,24	0,32		0,08	0,04	0,03	0,02	0,01	0,01	11600	1158			
820	4945,64	0,28		0,07	0,03	0,02	0,02	0,01	0,01	11600	1160			
590	3,27	429	MT472	-	27,21	20,52	18,11	13,00	11,06	5240	-	76	342	MT023
650	3,83	365	NT472	39,94	25,56	19,02	16,93	12,11	10,23	5434	-	80		NT023
710	4,54	309		37,12	23,63	17,60	15,58	11,22	9,50	5672	-			
800	4,89	287		39,93	24,68	18,11	16,11	11,30	9,50	5567	-			
925	5,66	247		-	24,70	18,51	16,31	11,46	9,61	5876	-			
985	6,65	211		36,28	22,43	16,52	14,52	10,22	8,56	6172	-			
1020	7,87	178		32,05	19,67	14,48	12,81	9,02	7,54	6595	-			
1025	8,47	165		29,71	18,32	13,49	11,88	8,37	6,99	6822	-			
1050	9,53	147		27,23	16,70	12,41	10,95	7,68	6,22	7144	-			
1100	10,79	130		25,06	15,47	11,38	10,03	7,04	5,50	7430	-			
1165	12,05	116		23,66	14,65	10,78	9,50	6,31	4,91	7798	-			
1205	13,56	103		21,83	13,48	9,92	8,76	5,61	4,37	8130	-			
1250	15,35	91		19,99	12,37	9,09	8,01	4,96	3,87	8491	-			
1295	17,25	81		18,44	11,42	8,39	7,35	4,42	3,44	8840	-			
1450	18,72	75		19,72	11,77	8,11	6,77	4,07	3,17	8737	-			
1455	22,15	63		16,97	10,00	6,87	5,73	3,45	2,68	9470	-			
1550	18,04	78	MT473	13,47	13,14	8,49	7,09	4,27	3,33	8072	-	78	342	MT024
1550	21,74	64	NT473	12,60	10,93	7,06	5,89	3,56	2,77	8893	-	82		NT024
1550	25,67	55		13,63	9,24	5,97	4,99	3,01	2,34	9884	565			
1550	30,93	45		12,32	7,69	4,97	4,15	2,50	1,95	10807	996			
1550	37,45	37		10,20	6,37	4,11	3,43	2,07	1,61	11817	1362			
1550	42,75	33		9,35	5,59	3,61	3,02	1,82	1,42	12553	1563			



Motorsuz Güç Devir Sayfaları

Gear Units Performance Tables

Leistung und Drehzahlübersicht von Getriebe

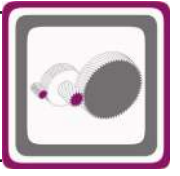

Anma Momenti <i>Nominal Torques</i> Nenn-drehmomente Ma [Nm] (n1=1400rpm)	Çevrim Oranı <i>Ratio</i> Übersetzung i	Çıkış Devri <i>Output Speeds</i> Abtriebs-drehzahlen n2 [r.p.m] (n1=1400rpm)	Tipi <i>Type</i> Typ	Pe= Nominal Güç [kW] (Servis Faktörü fs=1,0 için) <i>Pe= Nominal Power [kW] (For Service Factor fs=1,0)</i> Pe= NennLeistung [kW] (Bei Betriebsfaktor fs=1,0)						Güv. Rad.Yük Çıkış <i>Per.O.Loads (Output)</i>	Güv.Rad.Yük Giriş <i>Per.O.Loads (Input)</i>	Ağırlık <i>Weight</i> Gewicht [kg]	Ölçü Sayfası <i>Dim. Page</i> Maße Seite	Fiyat Kodu <i>Price Ref.</i> Preis No.
				Giriş devri[d/d] / Input speed[rpm] / Antriebsdrehzahl[upm]										
				n1=2800	n1=1400	n1=900	n1=750	n1=450	n1=350					
1550	49,05	29	MT473	8,54	4,88	3,15	2,63	1,59	1,24	13354	1614	78	342	MT024
1550	55,82	25	NT473	7,75	4,29	2,77	2,31	1,39	1,09	14141	1848	82		NT024
1550	63,70	22		7,00	3,77	2,43	2,03	1,22	0,95	14982	1886			
1550	73,09	19		6,52	3,29	2,13	1,77	1,07	0,83	15600	1920			
1550	84,46	17		5,67	2,86	1,84	1,54	0,93	0,72	15600	1952			
1550	86,52	16		5,53	2,79	1,80	1,50	0,90	0,70	15600	1959			
1550	91,58	15		5,23	2,63	1,70	1,42	0,85	0,67	15600	1970			
1550	109,64	13		4,38	2,21	1,42	1,19	0,72	0,56	15600	2000			
1550	124,85	11		3,86	1,94	1,25	1,05	0,63	0,49	15600	2019			
1550	139,54	10		3,46	1,74	1,12	0,94	0,56	0,44	15600	2036			
1550	157,90	8,9		3,06	1,54	0,99	0,83	0,50	0,39	15600	2049			
1550	194,05	7,2		2,51	1,26	0,81	0,68	0,41	0,32	15600	2068			
1550	219,00	6,4		2,22	1,12	0,72	0,60	0,36	0,28	15600	2077			
1550	229,46	6,1	MT474	2,15	1,07	0,69	0,57	0,34	0,27	15600	1490	72	343	MT025
1550	259,55	5,4	NT474	1,90	0,95	0,61	0,51	0,31	0,26	15600	1500	76		NT025
1550	295,98	4,7		1,67	0,83	0,54	0,45	0,27	0,23	15600	1509			
1550	346,07	4,0		1,43	0,71	0,46	0,38	0,26	0,20	15600	1518			
1550	418,16	3,3		1,19	0,59	0,38	0,32	0,21	0,16	15600	1527			
1550	442,61	3,2		1,12	0,56	0,36	0,30	0,20	0,16	15600	1539			
1550	529,93	2,6		0,94	0,47	0,30	0,25	0,17	0,13	15600	1573			
1550	603,46	2,3		0,82	0,41	0,26	0,25	0,15	0,11	15600	1594			
1550	674,46	2,1		0,74	0,37	0,26	0,22	0,13	0,10	15600	1610			
1550	726,85	1,9	MT475	0,70	0,35	0,25	0,21	0,12	0,10	15600	1772	88	344	MT026
1550	871,52	1,6	NT475	0,58	0,29	0,21	0,17	0,10	0,08	15600	1778	92		NT026
1550	934,94	1,5		0,54	0,27	0,19	0,16	0,10	0,08	15600	1779			
1550	1053,93	1,3		0,54	0,27	0,19	0,16	0,10	0,07	15600	1783			
1550	1204,49	1,2		0,47	0,23	0,17	0,14	0,08	0,07	15600	1785			
1550	1285,79	1,1		0,44	0,22	0,16	0,13	0,08	0,06	15600	1787			
1550	1386,75	1,0		0,41	0,20	0,15	0,12	0,07	0,06	15600	1788			
1550	1631,08	0,86		0,35	0,17	0,12	0,10	0,06	0,05	15600	1791			
1550	1738,98	0,81		0,33	0,16	0,12	0,10	0,06	0,05	15600	1792			
1550	1990,76	0,70		0,29	0,14	0,10	0,09	0,05	0,04	15600	1793			
1550	2107,15	0,66		0,27	0,13	0,10	0,08	0,05	0,04	15600	1796			
1550	2522,85	0,55		0,25	0,11	0,08	0,07	0,04	0,03	15600	1804			
1550	3115,96	0,45	MT476	0,21	0,09	0,07	0,06	0,03	0,03	15600	1822	90	344	MT027
1550	3561,10	0,39	NT476	0,18	0,08	0,06	0,05	0,03	0,02	15600	1823	94		NT027
1550	3801,48	0,37		0,17	0,08	0,05	0,05	0,03	0,02	15600	1824			
1550	4099,95	0,34		0,16	0,07	0,05	0,04	0,03	0,02	15600	1824			
1550	4822,33	0,29		0,13	0,06	0,04	0,04	0,02	0,02	15600	1825			
1550	5141,34	0,27		0,13	0,06	0,04	0,03	0,02	0,02	15600	1825			
1550	5885,71	0,24		0,11	0,05	0,04	0,03	0,02	0,01	15600	1826			
1550	6229,83	0,22		0,10	0,05	0,03	0,03	0,02	0,01	15600	1827			
1550	7458,85	0,19		0,09	0,04	0,03	0,02	0,01	0,01	15600	1830			
1830	4,37	321	MT572	-	63,03	46,86	41,51	29,46	26,09	7626	-	109	345	MT053
1910	4,95	283	NT572	-	58,14	43,38	38,32	27,22	23,05	7727	-	119		NT053
1980	5,63	249		-	53,05	39,56	35,03	24,83	20,29	8090	-			
2080	6,43	218		-	48,78	36,29	32,05	22,79	17,76	8505	-			
2180	7,41	189		-	44,43	32,99	29,17	19,81	15,43	8933	-			
2160	8,34	168		-	39,13	28,85	25,34	17,60	13,71	9439	-			
2200	9,48	148		-	35,08	25,81	22,73	15,49	12,07	10015	-			
2250	10,85	129		-	31,40	23,13	20,42	13,56	10,56	10605	-			
2320	12,50	112		-	28,14	20,73	18,21	11,78	9,18	11248	-			
2390	14,54	96		40,34	24,96	18,39	16,18	10,14	7,90	11965	-			
2460	17,07	82		35,40	21,87	16,11	14,20	8,63	6,72	12809	-			
2520	19,15	73		32,37	19,99	14,73	12,80	7,70	6,00	13383	-			
2650	23,02	61		28,26	17,50	12,77	10,65	6,41	4,99	14468	-			
2750	27,00	52		25,04	15,51	10,90	9,10	5,47	4,26	15633	-			



Motorsuz Güç Devir Sayfaları

Gear Units Performance Tables

Leistung und Drehzahlübersicht von Getriebe

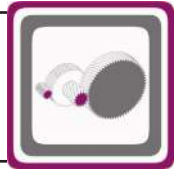

Anma Momenti Nominal Torques Nenn-drehmomente Ma [Nm] (n1=1400rpm)	Çevrim Oranı	Çıkış Devri	Tipi	Pe= Nominal Güç [kW] (Servis Faktörü fs=1,0 için)						Güv. Rad.Yük Çıkış	Güv.Rad.Yük Giriş	Ağırlık	Ölçü Sayfası	Fiyat Kodu
	Ratio	Output Speeds		Type	Pe= Nominal Power [kW] (For Service Factor fs=1,0)						Per.O.Loads (Output)			
	Übersetzung	Abtriebs-drehzahlen	Typ	Giriş devri[d/d] / Input speed[rpm] / Antriebsdrehzahl[upm]						Zul.Querkräfte (Abtrieb)	Zul.Querkräfte (Antrieb)	Gewicht	Maße Seite	Preis No.
	i	n2 [r.p.m] (n1=1400rpm)		n1=2800	n1=1400	n1=900	n1=750	n1=450	n1=350	Fqam [N] (n1=1400rpm)	Fqem [N] (n1=1400rpm)	[kg]		
2390	22,64	62	MT573	25,70	16,07	11,92	10,52	6,52	5,08	14923	578	111	345	MT054
2520	26,54	53	NT573	23,12	14,52	10,75	9,32	5,62	4,38	15734	647	121		NT054
2650	31,38	45		20,66	12,94	9,46	7,90	4,76	3,71	16788	710			
2750	35,31	40		19,09	11,96	8,43	7,04	4,24	3,31	17736	704			
2860	39,98	35		17,57	11,00	7,45	6,22	3,75	2,92	18777	668			
3000	48,74	29		15,38	9,48	6,12	5,11	3,08	2,40	19500	2669			
3000	54,74	26		13,81	8,45	5,45	4,55	2,74	2,14	19500	3008			
3000	64,72	22		12,30	7,15	4,62	3,85	2,32	1,81	19500	3078			
3000	72,81	19		11,34	6,37	4,11	3,43	2,07	1,61	19500	3121			
3000	82,45	17		10,44	5,63	3,64	3,04	1,83	1,43	19500	3161			
3000	100,53	14		9,13	4,63	2,99	2,49	1,50	1,17	19500	3213			
3000	118,95	12		7,78	3,92	2,53	2,11	1,27	0,99	19500	3250			
3000	134,45	10		6,90	3,48	2,24	1,87	1,13	0,88	19500	3274			
3000	153,61	9,1		6,06	3,05	1,97	1,64	0,99	0,77	19500	3296			
3000	167,32	8,4		5,57	2,81	1,81	1,51	0,91	0,71	19500	3311			
3000	194,15	7,2	MT574	4,91	2,46	1,58	1,32	0,79	0,61	19500	1627	128	346	MT055
3000	221,40	6,3	NT574	4,32	2,16	1,39	1,16	0,69	0,54	19500	1649	138		NT055
3000	258,87	5,4		3,69	1,85	1,19	0,99	0,59	0,46	19500	1673			
3000	291,25	4,8		3,29	1,64	1,06	0,88	0,53	0,41	19500	1738			
3000	301,59	4,6		3,17	1,59	1,02	0,85	0,51	0,40	19500	1852			
3000	343,91	4,1		2,78	1,39	0,90	0,75	0,45	0,35	19500	1867			
3000	402,12	3,5		2,38	1,19	0,77	0,64	0,38	0,30	19500	1882			
3000	485,89	2,9		1,98	0,99	0,64	0,53	0,32	0,27	19500	1897			
3000	574,90	2,4		1,67	0,84	0,54	0,45	0,27	0,23	19500	1953			
3000	620,62	2,3	MT575	1,59	0,79	0,51	0,43	0,26	0,22	19500	1535	132	347	MT056
3000	698,26	2,0	NT575	1,41	0,71	0,45	0,38	0,25	0,20	19500	1570	142		NT056
3000	790,68	1,8		1,25	0,62	0,40	0,33	0,22	0,17	19500	1601			
3000	964,05	1,5		1,02	0,51	0,33	0,27	0,18	0,14	19500	1645			
3000	1140,65	1,2		0,87	0,43	0,28	0,26	0,15	0,12	19500	1676			
3000	1259,61	1,1		0,79	0,39	0,25	0,23	0,14	0,11	19500	1691			
3000	1489,14	0,94		0,67	0,33	0,24	0,20	0,12	0,09	19500	1715			
3000	1675,43	0,84		0,59	0,30	0,21	0,18	0,11	0,08	19500	1729			
3000	1897,20	0,74		0,52	0,26	0,19	0,16	0,09	0,07	19500	1742			
3000	2313,18	0,61		0,48	0,24	0,17	0,14	0,09	0,07	19500	1760			
3000	2736,94	0,51		0,40	0,20	0,14	0,12	0,07	0,06	19500	1773			
3000	2850,22	0,49	MT576	0,39	0,20	0,14	0,12	0,07	0,05	19500	1776	134	347	MT057
3000	3372,36	0,42	NT576	0,33	0,17	0,12	0,10	0,06	0,05	19500	1786	144		NT057
3000	4402,68	0,32		0,26	0,13	0,09	0,08	0,05	0,04	19500	1800			
3000	4953,44	0,28		0,25	0,11	0,08	0,07	0,04	0,03	19500	1804			
3000	6838,96	0,20		0,18	0,08	0,06	0,05	0,03	0,02	19500	1815			
3000	8091,82	0,17		0,16	0,07	0,05	0,04	0,02	0,02	19500	1819			
2150	3,29	425	MT672	-	97,98	72,26	63,72	44,87	37,72	8475	-	171	348	MT058
2400	3,79	370	NT672	-	95,28	70,12	61,93	43,47	36,58	8443	-	181		NT058
2670	4,37	320		-	91,93	67,70	59,83	42,05	35,29	8444	-			
2700	4,53	309		-	89,55	66,08	58,17	40,94	34,41	8537	-			
2920	5,08	275		-	86,44	63,75	56,22	39,52	32,13	8931	-			
3170	5,73	244		-	83,34	61,37	54,18	36,63	28,54	9330	-			
2870	6,88	203		-	62,88	46,33	40,90	28,74	23,77	10601	-			
2920	7,91	177		-	55,74	41,11	36,35	25,54	20,71	11338	-			
2990	9,13	153		-	49,51	36,62	32,25	22,63	17,97	12104	-			
3030	9,47	148		-	48,33	35,58	31,41	22,06	17,31	12259	-			
3090	10,62	132		-	43,99	32,50	28,65	19,83	15,45	12883	-			
3170	11,97	117		-	40,09	29,51	26,05	17,61	13,72	13531	-			
3250	13,58	103		-	36,28	26,77	23,60	15,54	12,11	14261	-			
3350	15,53	90		52,95	32,75	24,14	21,30	13,61	10,60	15049	-			
3470	17,93	78		47,44	29,42	21,65	19,11	11,80	9,19	15925	-			
3580	20,74	68		42,30	26,23	19,32	16,94	10,20	7,94	16867	-			



Motorsuz Güç Devir Sayfaları

Gear Units Performance Tables

Leistung und Drehzahlübersicht von Getriebe

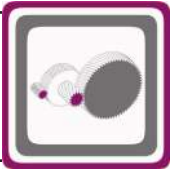

Anma Momenti <i>Nominal Torques</i> Nenn-drehmomente Ma [Nm] (n1=1400rpm)	Çevrim Oranı <i>Ratio</i> Übersetzung i	Çıkış Devri <i>Output Speeds</i> Abtriebs-drehzahlen n2 [r.p.m] (n1=1400rpm)	Tipi <i>Type</i> Typ	Pe= Nominal Güç [kW] (Servis Faktörü fs=1,0 için) <i>Pe= Nominal Power [kW] (For Service Factor fs=1,0)</i> Pe= NennLeistung [kW] (Bei Betriebsfaktor fs=1,0)						Güv. Rad.Yük Çıkış <i>Per.O.Loads (Output)</i>	Güv.Rad.Yük Giriş <i>Per.O.Loads (Input)</i>	Ağırlık <i>Weight</i> Gewicht [kg]	Ölçü Sayfası <i>Dim. Page</i> Maße Seite	Fiyat Kodu <i>Price Ref.</i> Preis No.
				Giriş devri[d/d] / Input speed[rpm] / Antriebsdrehzahl[upm]										
				n1=2800	n1=1400	n1=900	n1=750	n1=450	n1=350					
3680	23,18	60	MT672 NT672	38,93	24,15	17,81	15,18	9,13	7,11	17731	-	171 181	348	MT058 NT058
3530	26,66	53	MT673	-	20,27	15,05	13,28	8,03	6,26	19264	2705	199	348	MT059
3670	30,20	46	NT673	-	18,63	13,80	11,77	7,10	5,54	20176	2810	209		NT059
3820	34,36	41		-	17,08	12,42	10,37	6,25	4,87	21447	2884			
3990	39,30	36		-	15,62	10,87	9,08	5,47	4,27	22833	2909			
4160	45,29	31		22,66	14,17	9,46	7,90	4,76	3,71	24363	2932			
4300	52,68	27		20,51	12,62	8,15	6,80	4,10	3,20	26077	3012			
4300	53,99	26		19,75	12,28	7,93	6,62	3,99	3,11	26364	3664			
4300	61,42	23		18,09	10,82	6,99	5,83	3,52	2,74	26500	3730			
4300	70,26	20		16,50	9,48	6,12	5,11	3,08	2,40	26500	3790			
4300	80,96	17		15,04	8,24	5,32	4,44	2,68	2,09	26500	3845			
4300	94,17	15		13,59	7,10	4,59	3,83	2,31	1,80	26500	3895			
4300	110,55	13		12,02	6,05	3,91	3,26	1,96	1,53	26500	3960			
4300	124,07	11		10,74	5,41	3,49	2,91	1,75	1,37	26500	3988			
4300	149,11	9,4		8,95	4,51	2,91	2,43	1,46	1,14	26500	4023			
4300	174,89	8,0		7,66	3,85	2,49	2,07	1,25	0,97	26500	4051			
4300	196,61	7,1		6,83	3,44	2,22	1,85	1,11	0,87	26500	4068			
4300	215,97	6,5	MT674	6,33	3,17	2,04	1,70	1,02	0,79	26500	1737	205	349	MT060
4300	245,67	5,7	NT674	5,57	2,79	1,79	1,49	0,90	0,70	26500	1845	215		NT060
4300	281,02	5,0		4,88	2,44	1,57	1,31	0,78	0,61	26500	1944			
4300	323,82	4,3		4,24	2,12	1,36	1,14	0,68	0,53	26500	2035			
4300	376,69	3,7		3,65	1,83	1,17	0,98	0,59	0,46	26500	2188			
4300	442,20	3,2		3,11	1,55	1,00	0,83	0,50	0,39	26500	2194			
4300	500,39	2,8		2,75	1,37	0,88	0,74	0,44	0,34	26500	2207			
4300	583,04	2,4	MT675	2,41	1,21	0,77	0,65	0,39	0,30	26500	2063	214	350	MT061
4300	673,70	2,1	NT675	2,09	1,05	0,67	0,56	0,34	0,26	26500	2073	225		NT061
4300	730,46	1,9		1,93	0,96	0,62	0,52	0,31	0,27	26500	2079			
4300	874,56	1,6		1,61	0,81	0,52	0,43	0,26	0,22	26500	2089			
4300	995,91	1,4		1,42	0,71	0,46	0,38	0,25	0,20	26500	2095			
4300	1113,08	1,3		1,27	0,64	0,41	0,34	0,23	0,18	26500	2100			
4300	1259,54	1,1		1,12	0,56	0,36	0,30	0,20	0,16	26500	2105			
4300	1432,74	0,98		0,99	0,49	0,32	0,26	0,18	0,14	26500	2124			
4300	1638,93	0,85		0,87	0,43	0,28	0,26	0,15	0,12	26500	2141			
4300	1888,53	0,74		0,75	0,38	0,27	0,22	0,13	0,10	26500	2156			
4300	2196,86	0,64		0,65	0,32	0,23	0,19	0,12	0,09	26500	2171			
4300	2578,93	0,54		0,55	0,28	0,20	0,16	0,10	0,08	26500	2184			
4300	2863,86	0,49	MT676	0,51	0,25	0,18	0,15	0,09	0,07	26500	2217	217	350	MT062
4300	3342,43	0,42	NT676	0,48	0,24	0,17	0,14	0,09	0,07	26500	2220	229		NT062
4300	3931,45	0,36		0,41	0,21	0,15	0,12	0,07	0,06	26500	2222			
4300	4674,12	0,30		0,35	0,17	0,12	0,10	0,06	0,05	26500	2224			
4300	5287,12	0,26		0,31	0,15	0,11	0,09	0,05	0,04	26500	2225			
4300	6029,17	0,23		0,27	0,13	0,10	0,08	0,05	0,04	26500	2227			
4300	7490,08	0,19		0,24	0,11	0,08	0,06	0,04	0,03	26500	2228			
4300	8518,13	0,16		0,21	0,10	0,07	0,06	0,03	0,03	26500	2229			
4300	9689,49	0,14		0,19	0,08	0,06	0,05	0,03	0,02	26500	2233			
4300	11083,95	0,13		0,16	0,07	0,05	0,04	0,03	0,02	26500	2236			
4300	12771,99	0,11		0,14	0,06	0,05	0,04	0,02	0,02	26500	2239			
4300	14857,21	0,09		0,12	0,05	0,04	0,03	0,02	0,02	26500	2242			
4300	17441,07	0,08		0,10	0,05	0,03	0,03	0,02	0,01	26500	2244			
3680	4,73	296	MT772	-	116,86	86,18	76,01	53,49	44,96	21227	-	296	351	MT063
3990	5,38	260	NT772	-	111,51	82,34	72,61	50,97	42,96	21945	-	365		NT063
4330	6,15	227		-	105,91	78,06	68,82	48,42	40,69	22723	-			
4490	6,52	215		-	103,60	76,32	67,28	47,32	39,78	23051	-			
4770	7,26	193		-	98,91	72,87	64,26	45,22	38,00	23723	-			
6200	8,46	166		-	110,54	82,53	73,27	46,20	35,99	25853	-			



Motorsuz Güç Devir Sayfaları

Gear Units Performance Tables

Leistung und Drehzahlübersicht von Getriebe

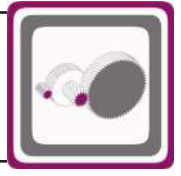

Anma Momenti <i>Nominal Torques</i> Nenn-drehmomente Ma [Nm] (n1=1400rpm)	Çevrim Oranı <i>Ratio</i> Übersetzung i	Çıkış Devri <i>Output Speeds</i> Abtriebs-drehzahlen n2 [r.p.m] (n1=1400rpm)	Tipi <i>Type</i> Typ	Pe= Nominal Güç [kW] (Servis Faktörü fs=1,0 için) <i>Pe= Nominal Power [kW] (For Service Factor fs=1,0)</i> Pe= NennLeistung [kW] (Bei Betriebsfaktor fs=1,0)						Güv. Rad.Yük Çıkış <i>Per.O.Loads (Output)</i> Zul.Querkräfte (Abtrieb) Fqam [N] (n1=1400rpm)	Güv.Rad.Yük Giriş <i>Per.O.Loads (Input)</i> Zul.Querkräfte (Antrieb) Fqem [N] (n1=1400rpm)	Ağırlık <i>Weight</i> Gewicht [kg]	Ölçü Sayfası <i>Dim. Page</i> Maße Seite	Fiyat Kodu <i>Price Ref.</i> Preis No.
				Giriş devri[d/d] / Input speed[rpm] / Antriebsdrehzahl[upm]										
				n1=2800	n1=1400	n1=900	n1=750	n1=450	n1=350					
6470	9,62	146	MT772	-	101,52	75,67	67,19	40,66	31,68	26990	-	296	351	MT063
6770	11,00	127	NT772	-	92,98	69,42	59,11	35,59	27,72	28223	-	365		NT063
6900	11,65	120	-	-	89,40	66,74	55,76	33,57	26,15	28769	-			
7140	12,98	108	-	-	83,14	60,06	50,11	30,17	23,50	29836	-			
7420	14,54	96	-	-	77,23	53,69	44,80	26,97	21,01	30977	-			
7710	16,39	85	-	-	71,27	47,68	39,78	23,95	18,65	32257	-			
7520	17,40	80	MT773	-	65,83	45,23	37,76	22,78	17,77	30017	-	259	351	MT064
7810	19,52	72	NT773	-	61,05	40,39	33,72	20,34	15,86	31192	-	320		NT064
8000	22,62	62	-	-	53,97	34,85	29,09	17,55	13,69	36646	-			
8000	25,99	54	-	-	47,04	30,38	25,37	15,30	11,93	38850	-			
8000	30,00	47	-	-	40,83	26,37	22,02	13,28	10,36	41230	-			
8000	31,11	45	-	-	39,34	25,41	21,21	12,80	9,98	41850	-			
8000	34,89	40	-	-	35,13	22,69	18,94	11,43	8,91	43853	-			
8000	39,33	36	-	-	31,22	20,16	16,83	10,15	7,91	46022	-			
8000	44,17	32	-	-	27,81	17,96	15,00	9,04	7,05	48202	4431			
8000	50,75	28	-	-	24,25	15,66	13,07	7,89	6,15	48500	4571			
8000	58,59	24	-	-	21,05	13,59	11,35	6,84	5,33	48500	4696			
8000	60,76	23	-	-	20,28	13,10	10,93	6,59	5,14	48500	4706			
8000	68,15	21	-	-	18,11	11,70	9,77	5,89	4,59	48500	4791			
8000	76,81	18	-	-	16,10	10,39	8,68	5,23	4,08	48500	4869			
8000	87,13	16	-	-	14,22	9,18	7,66	4,62	3,60	48500	4942			
8000	99,63	14	24,75	12,46	8,05	6,72	4,05	3,15	48500	5009				
8000	115,06	12	21,49	10,82	6,98	5,83	3,51	2,74	48500	5072				
8000	133,05	11	18,58	9,36	6,04	5,04	3,04	2,37	48500	5147				
8000	148,73	9,4	16,66	8,39	5,41	4,52	2,72	2,12	48500	5183				
8000	178,78	7,8	13,89	6,99	4,51	3,76	2,27	1,77	48500	5236				
8000	208,82	6,7	11,92	6,00	3,87	3,23	1,95	1,51	48500	5272				
8000	190,96	7,3	MT774	13,29	6,64	4,27	3,56	2,14	1,66	48500	-	269	352	MT065
8000	214,17	6,5	NT774	11,86	5,93	3,81	3,18	1,91	1,48	48500	-	330		NT065
8000	241,42	5,8	-	10,53	5,27	3,39	2,82	1,69	1,32	48500	616			
8000	273,85	5,1	-	9,30	4,65	2,99	2,49	1,49	1,16	48500	1258			
8000	313,11	4,5	-	8,14	4,07	2,62	2,18	1,31	1,02	48500	1665			
8000	361,62	3,9	-	7,06	3,53	2,27	1,89	1,13	0,88	48500	1794			
8000	418,17	3,3	-	6,10	3,05	1,96	1,63	0,98	0,76	48500	1908			
8000	467,43	3,0	-	5,46	2,73	1,76	1,46	0,88	0,68	48500	1984			
8000	532,29	2,6	-	4,81	2,40	1,54	1,29	0,77	0,60	48500	2007			
8000	594,92	2,4	-	4,30	2,15	1,38	1,15	0,69	0,54	48500	2027			
8000	641,40	2,2	MT775	4,08	2,04	1,31	1,09	0,66	0,51	48500	1748	328	353	MT066
8000	725,80	1,9	NT775	3,61	1,81	1,16	0,97	0,58	0,45	48500	1762	400		NT066
8000	822,02	1,7	-	3,18	1,59	1,02	0,85	0,51	0,40	48500	1961			
8000	984,18	1,4	-	2,67	1,33	0,86	0,71	0,43	0,33	48500	1978			
8000	1120,74	1,2	-	2,35	1,17	0,75	0,63	0,38	0,29	48500	1988			
8000	1252,60	1,1	-	2,10	1,05	0,67	0,56	0,34	0,26	48500	1997			
8000	1417,41	0,99	-	1,86	0,93	0,60	0,50	0,30	0,26	48500	2005			
8000	1589,68	0,88	-	1,66	0,83	0,53	0,44	0,27	0,23	48500	2032			
8000	1791,91	0,78	-	1,47	0,74	0,47	0,39	0,26	0,20	48500	2058			
8000	2032,66	0,69	-	1,30	0,65	0,42	0,35	0,23	0,18	48500	2082			
8000	2324,10	0,60	-	1,14	0,57	0,37	0,30	0,20	0,16	48500	2104			
8000	2684,10	0,52	-	0,99	0,49	0,32	0,26	0,18	0,14	48500	2125			
8000	3103,85	0,45	-	0,85	0,43	0,27	0,25	0,15	0,12	48500	2143			
8000	3814,39	0,37	-	0,69	0,35	0,25	0,21	0,12	0,10	48500	2148			
8000	4263,81	0,33	-	0,62	0,31	0,22	0,18	0,11	0,09	48500	2159			
8000	4812,09	0,29	-	0,55	0,28	0,20	0,16	0,10	0,08	48500	2161			
8000	2916,59	0,48	MT776	0,92	0,46	0,30	0,27	0,16	0,13	48500	2187	332	353	MT067
8000	3222,83	0,43	NT776	0,84	0,42	0,27	0,25	0,15	0,12	48500	2190	405		NT067
8000	3761,39	0,37	-	0,72	0,36	0,26	0,21	0,13	0,10	48500	2194			



Motorsuz Güç Devir Sayfaları

Gear Units Performance Tables

Leistung und Drehzahlübersicht von Getriebe

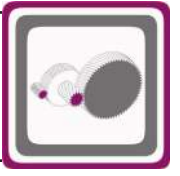

Anma Momenti <i>Nominal Torques</i> Nenn-drehmomente Ma [Nm] (n1=1400rpm)	Çevrim Oranı <i>Ratio</i> Übersetzung i	Çıkış Devri <i>Output Speeds</i> Abtriebs-drehzahlen n2 [r.p.m] (n1=1400rpm)	Tipi <i>Type</i> Typ	Pe= Nominal Güç [kW] (Servis Faktörü fs=1,0 için) <i>Pe= Nominal Power [kW] (For Service Factor fs=1,0)</i> Pe= NennLeistung [kW] (Bei Betriebsfaktor fs=1,0)						Güv. Rad.Yük Çıkış <i>Per.O.Loads (Output)</i>	Güv.Rad.Yük Giriş <i>Per.O.Loads (Input)</i>	Ağırlık <i>Weight</i> Gewicht [kg]	Ölçü Sayfası <i>Dim. Page</i> Maße Seite	Fiyat Kodu <i>Price Ref.</i> Preis No.
				Giriş devri[d/d] / Input speed[rpm] / Antriebsdrehzahl[upm]										
				n1=2800	n1=1400	n1=900	n1=750	n1=450	n1=350					
8000	4424,24	0,32	MT776	0,61	0,31	0,22	0,18	0,11	0,08	48500	2198	332	353	MT067
8000	5260,00	0,27	NT776	0,52	0,26	0,18	0,15	0,09	0,07	48500	2201	405		NT067
8000	5949,83	0,24		0,51	0,25	0,18	0,15	0,09	0,07	48500	2204			
8000	6784,90	0,21		0,45	0,22	0,16	0,13	0,08	0,06	48500	2206			
8000	8428,93	0,17		0,36	0,18	0,13	0,11	0,06	0,05	48500	2208			
8000	9585,84	0,15		0,32	0,16	0,11	0,09	0,06	0,04	48500	2210			
8000	10750,89	0,13		0,28	0,14	0,10	0,08	0,05	0,04	48500	2215			
8000	12118,56	0,12		0,25	0,13	0,09	0,07	0,04	0,03	48500	2220			
8000	13746,73	0,10		0,25	0,11	0,08	0,07	0,04	0,03	48500	2225			
8000	15717,68	0,09		0,21	0,10	0,07	0,06	0,03	0,03	48500	2229			
8000	18152,38	0,08		0,19	0,08	0,06	0,05	0,03	0,02	48500	2233			
8000	20991,08	0,07		0,16	0,07	0,05	0,04	0,03	0,02	48500	2236			
8000	23464,25	0,06		0,14	0,06	0,05	0,04	0,02	0,02	48500	2239			
8700	4,32	324	MT872	-	307,71	225,10	198,95	138,70	114,95	54833	-	550	354	MT043
9000	4,95	283	NT872	-	277,41	204,09	179,16	125,82	100,17	57334	-	560		NT043
9550	5,22	268		-	279,26	204,90	180,93	122,19	95,03	43596	-			
9900	5,99	234		-	252,28	185,93	163,13	106,48	82,82	45656	-			
10200	6,64	211		-	234,53	172,20	151,51	96,08	74,73	47129	-			
10600	7,55	185		-	214,29	157,25	137,54	84,48	65,70	48992	-			
11200	8,87	158		-	192,83	141,12	119,90	71,94	55,95	76122	-			
11500	10,09	139		-	174,08	126,51	105,42	63,25	49,20	79405	-			
12700	11,59	121	MT873	-	170,91	112,46	93,72	56,23	43,74	75784	-	555	354	MT044
13000	13,30	105	NT873	-	152,46	98,01	81,67	49,00	38,11	72000	-	565		NT044
13000	14,02	100		-	144,63	92,98	77,48	46,49	36,16	57957	-			
13000	16,09	87		-	126,04	81,03	67,52	40,51	31,51	62738	-			
13000	17,83	79		-	113,73	73,11	60,93	36,56	28,43	66441	-			
13000	20,28	69		-	99,99	64,28	53,57	32,14	25,00	71241	-			
13000	23,87	59		-	84,92	54,59	45,50	27,30	21,23	72000	-			
13000	27,39	51		-	74,01	47,58	39,65	23,79	18,50	72000	-			
13000	30,36	46		-	66,78	42,93	35,77	21,46	16,69	72000	-			
13000	34,53	41		-	58,71	37,74	31,45	18,87	14,68	72000	-			
13000	40,55	35		-	50,00	32,14	26,79	16,07	12,50	72000	1072			
13000	46,12	30		-	43,96	28,26	23,55	14,13	10,99	72000	1795			
13000	52,86	26		-	38,36	24,66	20,55	12,33	9,59	72000	2466			
13000	56,54	25		71,71	35,86	23,05	19,21	11,53	8,96	72000	-			
13000	64,77	22		62,60	31,30	20,12	16,77	10,06	7,83	72000	-			
13000	75,51	19		53,70	26,85	17,26	14,38	8,63	6,71	72000	3698			
13000	86,51	16		46,87	23,44	15,07	12,56	7,53	5,86	72000	4108			
13000	99,81	14		40,63	20,31	13,06	10,88	6,53	5,08	72000	4705			
13000	110,17	13		36,81	18,40	11,83	9,86	5,92	4,60	72000	4844			
13000	107,60	13	MT874	38,04	19,02	12,23	10,19	6,11	4,76	72000	681	590	355	MT045
13000	125,70	11	NT874	32,63	16,31	10,49	8,74	5,24	4,08	72000	1284	600		NT045
13000	147,61	9,5		27,84	13,92	8,95	7,46	4,47	3,48	72000	1816			
13000	174,68	8,0		23,59	11,79	7,58	6,32	3,79	2,95	72000	2288			
13000	188,08	7,4		21,87	10,93	7,03	5,86	3,51	2,73	72000	2623			
13000	211,60	6,6		19,47	9,73	6,26	5,21	3,13	2,43	72000	2686			
13000	239,61	5,8		17,22	8,61	5,53	4,61	2,77	2,15	72000	2746			
13000	292,15	4,8		14,14	7,07	4,54	3,79	2,27	1,77	72000	2823			
13000	345,67	4,1		11,97	5,99	3,85	3,21	1,92	1,50	72000	2880			
13000	390,74	3,6		10,61	5,30	3,41	2,84	1,71	1,33	72000	2916			
13000	446,42	3,1		9,30	4,65	2,99	2,49	1,50	1,16	72000	2950			
13000	495,97	2,8	MT875	8,55	4,28	2,75	2,29	1,37	1,07	72000	1496	618	356	MT046
13000	537,75	2,6	NT875	7,89	3,94	2,53	2,11	1,27	0,99	72000	1520	628		NT046
13000	643,84	2,2		6,60	3,30	2,12	1,77	1,06	0,83	72000	1561			
13000	718,74	1,9		5,92	2,96	1,90	1,59	0,95	0,74	72000	1634			
13000	807,91	1,7		5,27	2,63	1,69	1,41	0,85	0,66	72000	1703			
13000	915,85	1,5		4,65	2,33	1,50	1,25	0,75	0,58	72000	1768			



Motorsuz Güç Devir Sayfaları

Gear Units Performance Tables

Leistung und Drehzahlübersicht von Getriebe

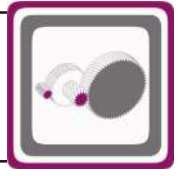

Anma Momenti <i>Nominal Torques</i> Nenn-drehmomente Ma [Nm] (n1=1400rpm)	Çevrim Oranı <i>Ratio</i> Übersetzung i	Çıkış Devri <i>Output Speeds</i> Abtriebs-drehzahlen n2 [r.p.m] (n1=1400rpm)	Tipi <i>Type</i> Typ	Pe= Nominal Güç [kW] (Servis Faktörü fs=1,0 için) <i>Pe= Nominal Power [kW] (For Service Factor fs=1,0)</i> Pe= NennLeistung [kW] (Bei Betriebsfaktor fs=1,0)						Güv. Rad.Yük Çıkış <i>Per.O.Loads (Output)</i> Zul.Querkräfte (Abtrieb) Fqam [N] (n1=1400rpm)	Güv.Rad.Yük Giriş <i>Per.O.Loads (Input)</i> Zul.Querkräfte (Antrieb) Fqem [N] (n1=1400rpm)	Ağırlık <i>Weight</i> Gewicht [kg]	Ölçü Sayfası <i>Dim. Page</i> Maße Seite	Fiyat Kodu <i>Price Ref.</i> Preis No.
				Giriş devri[d/d] / Input speed[rpm] / Antriebsdrehzahl[upm]										
				n1=2800	n1=1400	n1=900	n1=750	n1=450	n1=350					
13000	1049,18	1,3	MT875	4,07	2,03	1,31	1,09	0,65	0,51	72000	1830	618	356	MT046
13000	1210,51	1,2	NT875	3,52	1,76	1,13	0,94	0,57	0,44	72000	1888	628		NT046
13000	1336,15	1,0		3,19	1,59	1,03	0,85	0,51	0,40	72000	1922			
13000	1521,55	0,92		2,81	1,40	0,90	0,75	0,45	0,35	72000	1935			
13000	1700,56	0,82		2,51	1,26	0,81	0,67	0,40	0,31	72000	1946			
13000	1924,32	0,73		2,22	1,11	0,71	0,60	0,36	0,28	72000	1955			
13000	2108,33	0,66	MT876	2,07	1,03	0,67	0,55	0,33	0,26	72000	2088	620	356	MT047
13000	2460,65	0,57	NT876	1,78	0,89	0,57	0,48	0,29	0,25	72000	2098	630		NT047
13000	2894,28	0,48		1,51	0,76	0,49	0,41	0,27	0,21	72000	2108			
13000	3441,02	0,41		1,28	0,64	0,41	0,34	0,23	0,18	72000	2117			
13000	3892,30	0,36		1,13	0,56	0,36	0,30	0,20	0,16	72000	2122			
13000	4438,59	0,32		0,99	0,50	0,32	0,27	0,18	0,14	72000	2127			
13000	4954,95	0,28		0,89	0,44	0,29	0,26	0,16	0,12	72000	2141			
13000	5569,66	0,25		0,79	0,40	0,25	0,24	0,14	0,11	72000	2154			
13000	6313,78	0,22		0,70	0,35	0,25	0,21	0,12	0,10	72000	2166			
13000	7233,00	0,19		0,61	0,31	0,22	0,18	0,11	0,08	72000	2178			
13000	8345,18	0,17		0,53	0,26	0,19	0,16	0,09	0,07	72000	2189			
13000	11443,34	0,12		0,43	0,21	0,15	0,13	0,08	0,06	72000	2198			
13000	13014,00	0,11		0,38	0,19	0,13	0,11	0,07	0,05	72000	2200			
13000	14977,32	0,09		0,33	0,16	0,12	0,10	0,06	0,05	72000	2202			
13000	17501,59	0,08		0,28	0,14	0,10	0,08	0,05	0,04	72000	2203			
9950	7,11	197	MT972	-	209,66	154,84	135,99	95,54	80,30	96156	23900	960	357	MT048
10700	7,92	177	NT972	-	202,71	149,00	131,45	92,36	77,46	98548	22386	1010		NT048
11450	8,86	158		-	193,98	143,08	126,22	88,63	74,41	101270	17560			
12350	9,99	140		-	185,87	136,82	120,24	84,60	68,38	104116	11280			
18000	11,56	121		-	234,26	151,02	126,00	75,87	59,11	94500	12624			
18000	12,86	109		-	210,63	135,79	113,30	68,22	53,15	94500	17217			
18000	14,40	97		-	188,37	121,45	101,33	61,01	47,53	94500	21524			
18000	16,23	86		-	167,35	107,90	90,03	54,20	42,23	94500	23900			
18000	18,15	77	MT973	-	150,34	97,05	81,03	48,89	38,13	94500	23900	1000	357	MT049
18000	20,36	69	NT973	-	134,23	86,66	72,36	43,66	34,05	94500	23900	1050		NT049
18000	22,95	61		-	119,26	77,01	64,30	38,79	30,25	94500	23900			
18000	26,03	54		-	105,31	68,01	56,79	34,26	26,72	94500	23900			
18000	29,49	47		-	92,89	59,97	50,07	30,21	23,56	94500	23900			
18000	33,08	42		-	82,94	53,56	44,72	26,98	21,04	94500	23900			
18000	37,29	38		-	73,70	47,59	39,74	23,97	18,69	94500	23900			
18000	42,30	33		-	65,09	42,04	35,10	21,17	16,51	94500	23900			
18000	48,86	29		-	56,33	36,37	30,37	18,32	14,28	94500	23900			
18000	54,80	26		-	50,30	32,48	27,12	16,36	12,75	94500	23900			
18000	61,77	23		-	44,70	28,87	24,10	14,54	11,33	94500	23900			
18000	70,07	20		-	39,48	25,50	21,29	12,84	10,01	94500	23900			
18000	82,20	17		-	33,69	21,76	18,16	10,95	8,54	94500	23900			
18000	91,56	15		-	30,30	19,57	16,34	9,85	7,68	94500	23900			
18000	102,69	14		-	27,07	17,48	14,59	8,80	6,85	94500	23900			
18000	116,17	12		-	23,98	15,48	12,93	7,79	6,07	94500	23900			
18000	132,83	11		41,76	21,03	13,58	11,33	6,83	5,32	94500	23900			
18000	150,02	9,3		36,97	18,62	12,02	10,03	6,04	4,71	94500	23900			
18000	166,73	8,4		33,33	16,78	10,83	9,04	5,45	4,24	94500	23900			
18000	186,95	7,5		29,80	15,00	9,68	8,08	4,87	3,79	94500	23900			
18000	172,08	8,1	MT974	32,93	16,47	10,59	8,82	5,29	4,12	94500	277	1050	358	MT050
18000	193,13	7,2	NT974	29,40	14,70	9,45	7,87	4,72	3,67	94500	466	1100		NT050
18000	216,03	6,5		26,33	13,17	8,46	7,05	4,23	3,29	94500	629			
18000	272,24	5,1		20,93	10,47	6,73	5,61	3,36	2,62	94500	1143			
18000	305,33	4,6		18,68	9,34	6,01	5,00	3,00	2,34	94500	2263			
18000	344,17	4,1		16,59	8,30	5,33	4,44	2,67	2,07	94500	3191			
18000	390,41	3,6		14,65	7,32	4,71	3,92	2,35	1,83	94500	3396			
18000	457,99	3,1		12,48	6,24	4,01	3,34	2,01	1,56	94500	3622			



Motorsuz Güç Devir Sayfaları

Gear Units Performance Tables

Leistung und Drehzahlübersicht von Getriebe

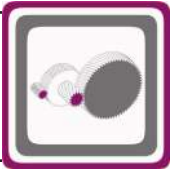

Anma Momenti Nominal Torques Nenn-drehmomente Ma [Nm] (n1=1400rpm)	Çevrim Oranı	Çıkış Devri	Tipi	Pe= Nominal Güç [kW] (Servis Faktörü fs=1,0 için)						Güv. Rad.Yük Çıkış	Güv.Rad.Yük Giriş	Ağırlık	Ölçü Sayfası	Fiyat Kodu
	Ratio	Output Speeds		Type	Pe= Nominal Power [kW] (For Service Factor fs=1,0)						Per.O.Loads (Output)	Per.O.Loads (Input)	Weight	Dim. Page
	Übersetzung	Abtriebs-drehzahlen	Typ	Giriş devri[d/d] / Input speed[rpm] / Antriebsdrehzahl[upm]						Zul.Querkräfte (Abtrieb)	Zul.Querkräfte (Antrieb)	Gewicht	Maße Seite	Preis No.
	i	n2 [r.p.m] (n1=1400rpm)		n1=2800	n1=1400	n1=900	n1=750	n1=450	n1=350	Fqam [N] (n1=1400rpm)	Fqem [N] (n1=1400rpm)	[kg]		
18000	510,11	2,7	MT974 NT974	11,22	5,61	3,61	3,01	1,80	1,40	94500	3755	1050 1100	358	MT050 NT050
18000	462,18	3,0	MT975	12,62	6,31	4,06	3,38	2,03	1,58	94500	1774	1100	359	MT051
18000	546,94	2,6	NT975	10,69	5,35	3,44	2,86	1,72	1,34	94500	1831	1150		NT051
18000	588,87	2,4		9,91	4,96	3,19	2,66	1,59	1,24	94500	1875			
18000	662,54	2,1		8,83	4,41	2,84	2,36	1,42	1,10	94500	1906			
18000	750,24	1,9		7,81	3,91	2,51	2,09	1,26	0,98	94500	1936			
18000	842,80	1,7		6,97	3,48	2,24	1,87	1,12	0,87	94500	1953			
18000	914,74	1,5		6,41	3,21	2,06	1,72	1,03	0,80	94500	1974			
18000	1082,31	1,3		5,43	2,72	1,75	1,46	0,87	0,68	94500	2002			
18000	1213,85	1,2		4,85	2,42	1,56	1,30	0,78	0,61	94500	2070			
18000	1368,27	1,0		4,30	2,15	1,38	1,15	0,69	0,54	94500	2133			
18000	1552,10	0,90		3,80	1,90	1,22	1,02	0,61	0,47	94500	2192			
18000	1820,78	0,77		3,24	1,62	1,04	0,87	0,52	0,40	94500	2257			
18000	2027,97	0,69		2,91	1,45	0,93	0,78	0,47	0,36	94500	2295			
18000	2836,64	0,49	MT976	2,12	1,06	0,68	0,57	0,34	0,26	94500	2427	1105	359	MT052
18000	3594,81	0,39	NT976	1,68	0,84	0,54	0,45	0,27	0,23	94500	2441	1155		NT052
18000	4227,50	0,33		1,43	0,71	0,46	0,38	0,26	0,20	94500	2494			
18000	4474,67	0,31		1,35	0,68	0,43	0,36	0,24	0,19	94500	2496			
18000	5357,43	0,26		1,13	0,57	0,36	0,30	0,20	0,16	94500	2504			
18000	6842,29	0,20		0,89	0,44	0,29	0,26	0,16	0,12	94500	2521			
18000	8620,11	0,16		0,70	0,35	0,25	0,21	0,13	0,10	94500	2537			
18000	11064,86	0,13		0,55	0,28	0,20	0,16	0,10	0,08	94500	2550			
18000	15951,72	0,09		0,42	0,21	0,15	0,13	0,08	0,06	94500	2565			
18000	20051,59	0,07		0,34	0,17	0,12	0,10	0,06	0,05	94500	2573			

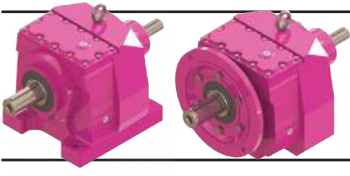

Ölçü Sayfaları

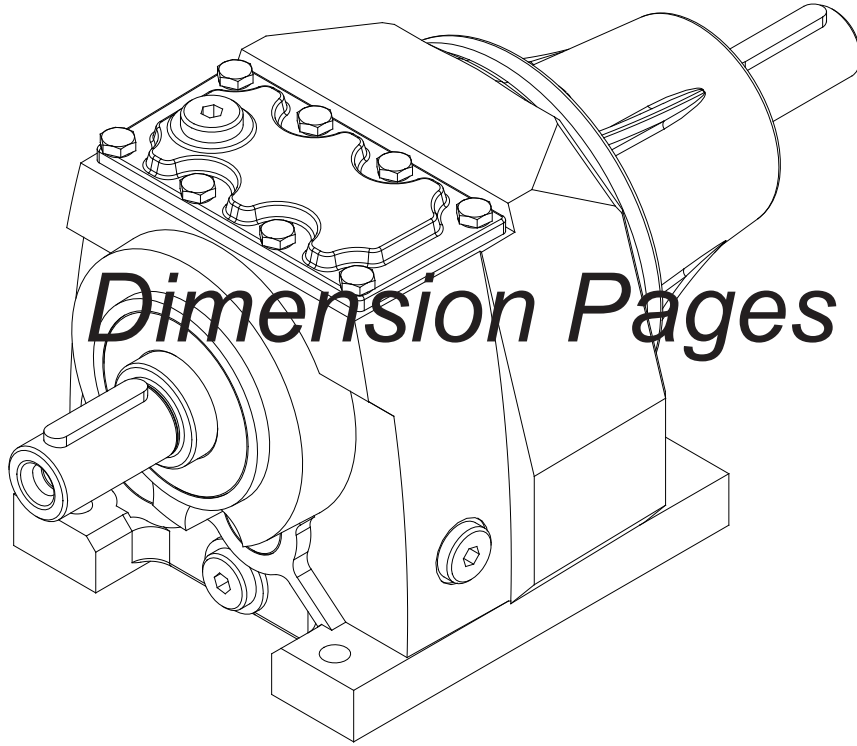

Abmessungsseiten

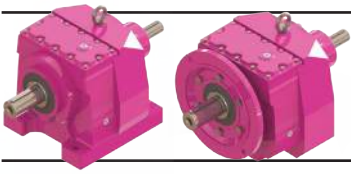

Ölçü Sayfaları Dimension Pages Abmessungenseiten



-Mil ucu çekirme deliği DIN 332 sayfa 2 / Tapped center hole to DIN 332, sheet 2 / Zentrierung mit gewinde DIN 332, Blatt 2

MT002 MT003

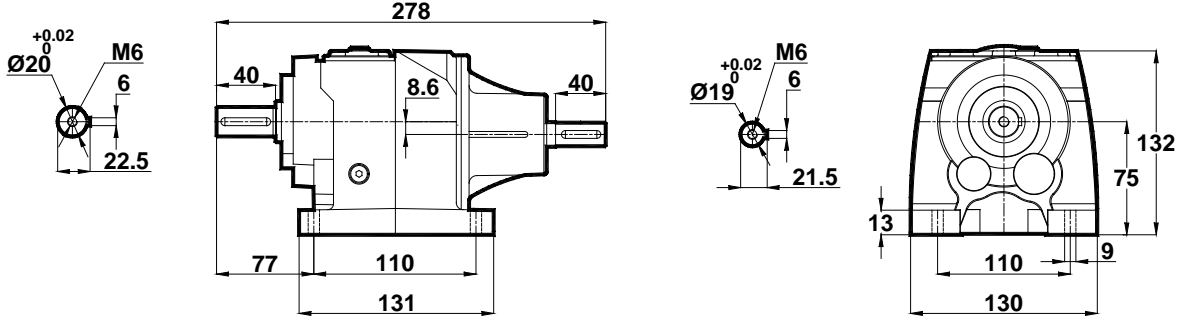

NT002 NT003

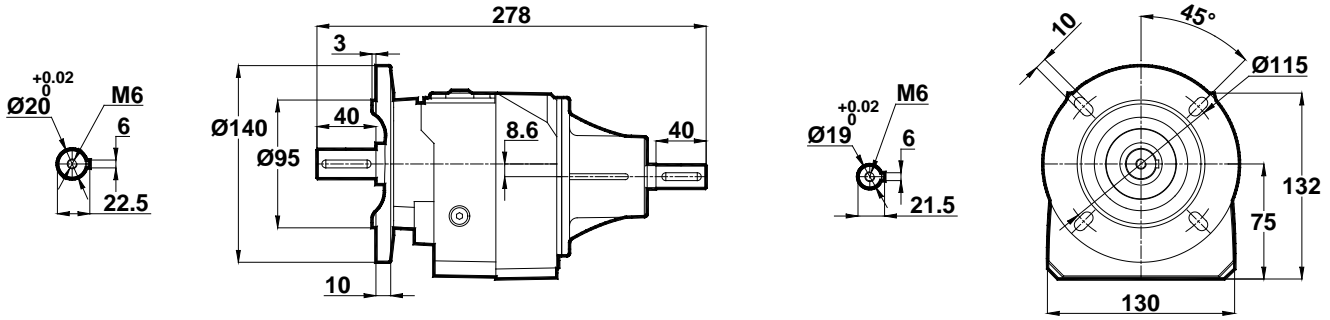

Opsiyonel Flanş Ölçüleri / Optional Flange Dimensions / Auswählbare Flanschabmessungen

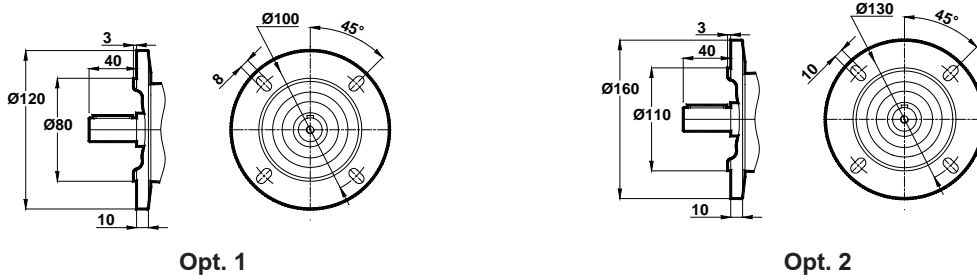

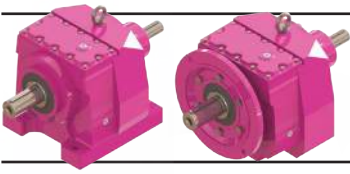

Ölçü Sayfaları Dimension Pages Abmessungsseiten



-Mil ucu çekirme deliği DIN 332 sayfa 2 / Tapped center hole to DIN 332, sheet 2 / Zentrierung mit gewinde DIN 332, Blatt 2

MT102 MT103

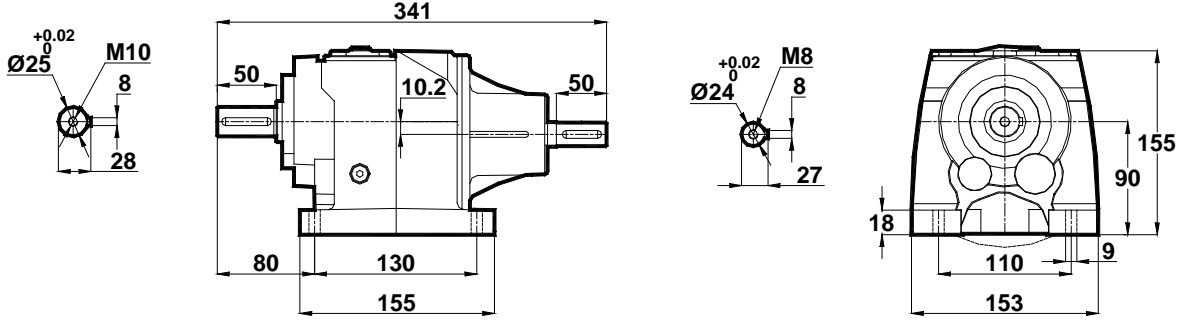

NT102 NT103

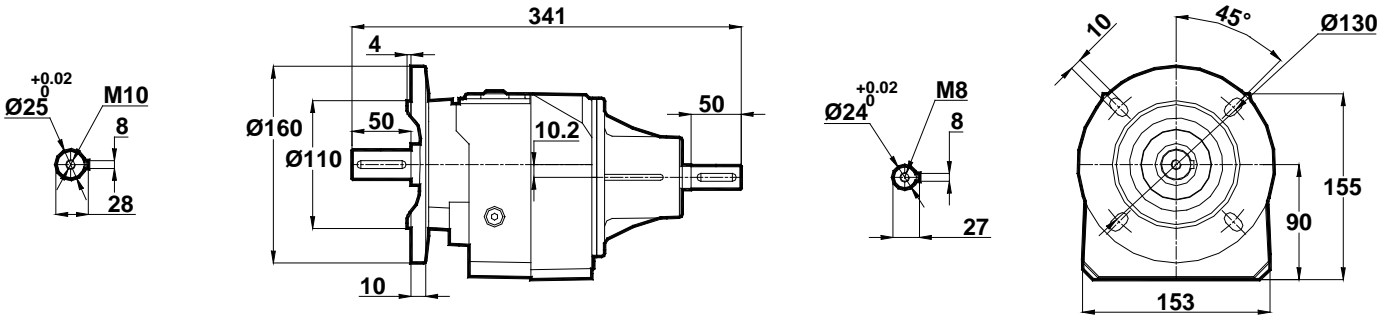

Opsiyonel Flanş Ölçüleri / Optional Flange Dimensions / Auswählbare Flanschabmessungen

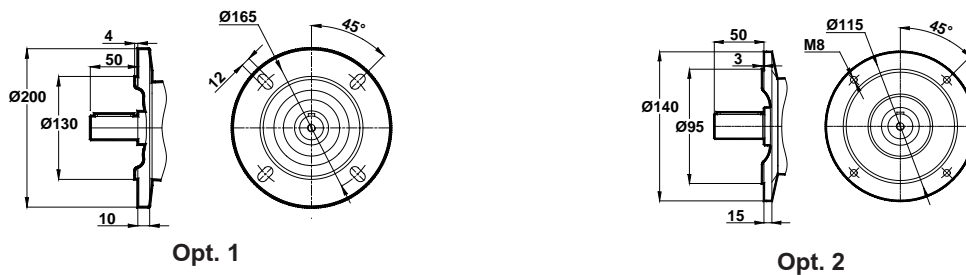

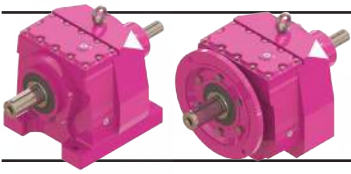

Ölçü Sayfaları Dimension Pages Abmessungenseiten



-Mil ucu çekirme deliği DIN 332 sayfa 2 / Tapped center hole to DIN 332, sheet 2 / Zentrierung mit gewinde DIN 332, Blatt 2

MT172 MT173

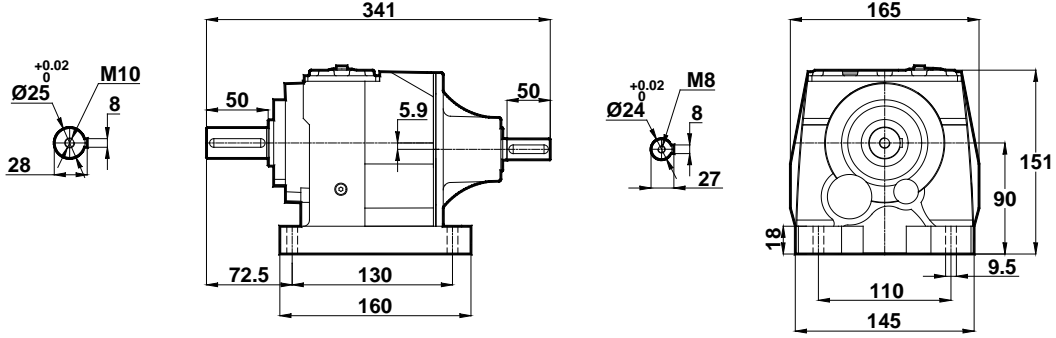

NT172 NT173

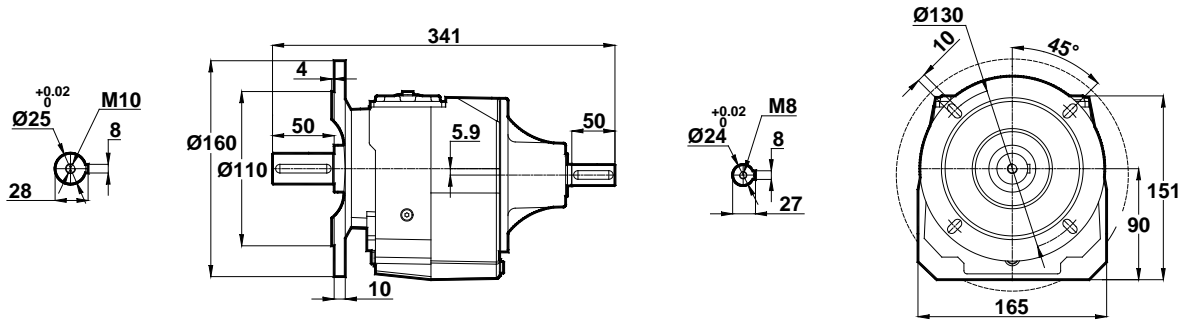

Opsiyonel Flaş Ölçüleri / Optional Flange Dimensions / Auswählbare Flanschabmessungen

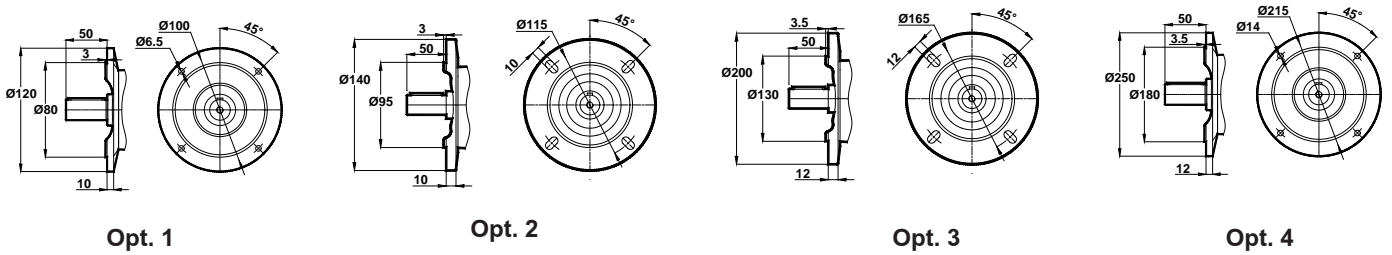

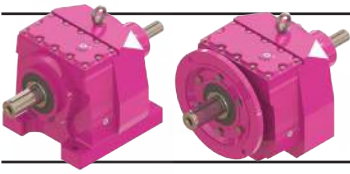

Ölçü Sayfaları Dimension Pages Abmessungenseiten



-Mil ucu çektirme deliği DIN 332 sayfa 2 / Tapped center hole to DIN 332, sheet 2 / Zentrierung mit gewinde DIN 332, Blatt 2

MT202 MT203

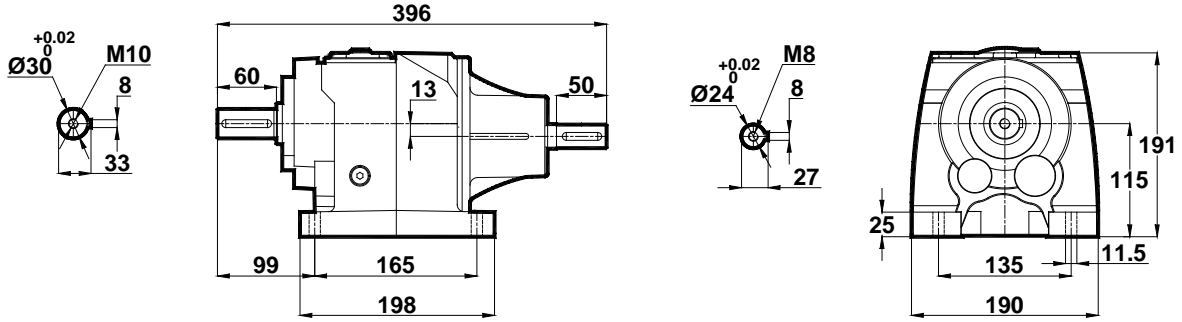

NT202 NT203

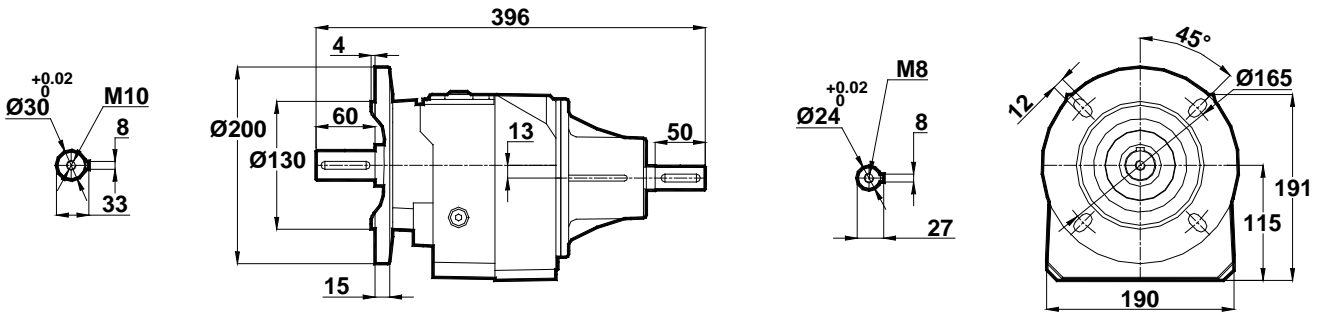

Opsiyonel Flanş Ölçüleri / Optional Flange Dimensions / Auswählbare Flanschabmessungen

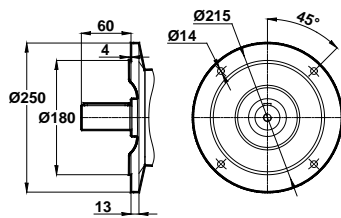

Opt. 1

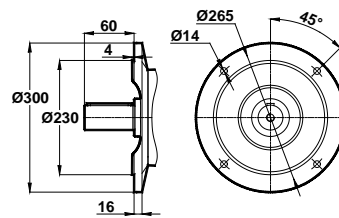

Opt. 2

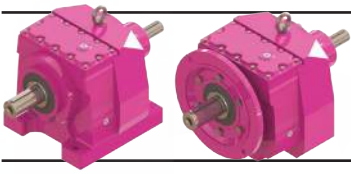

Ölçü Sayfaları Dimension Pages Abmessungenseiten



-Mil ucu çektirme deliği DIN 332 sayfa 2 / Tapped center hole to DIN 332, sheet 2 / Zentrierung mit gewinde DIN 332, Blatt 2

MT272 MT273

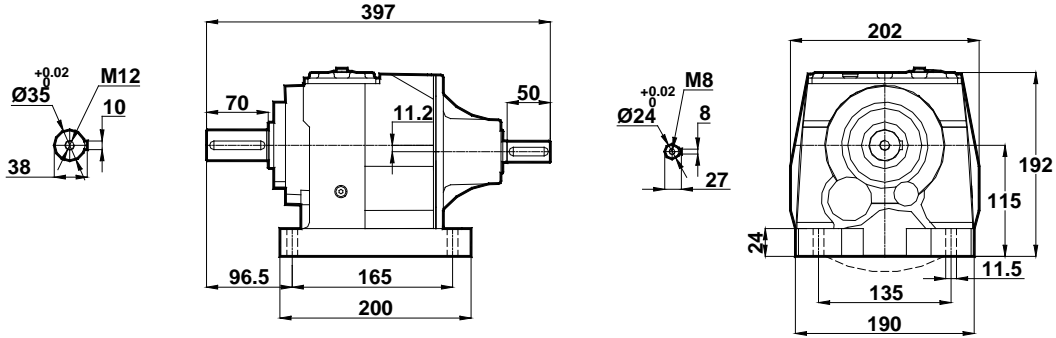

NT272 NT273

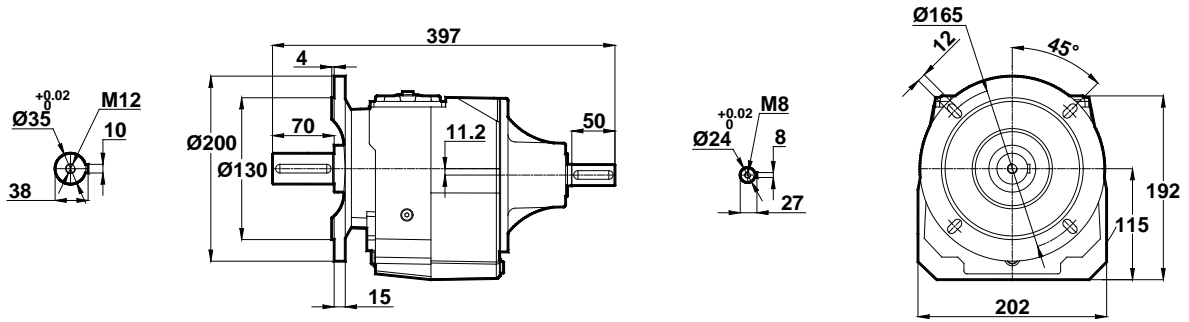

Opsiyonel Flanş Ölçüleri / Optional Flange Dimensions / Auswählbare Flanschabmessungen

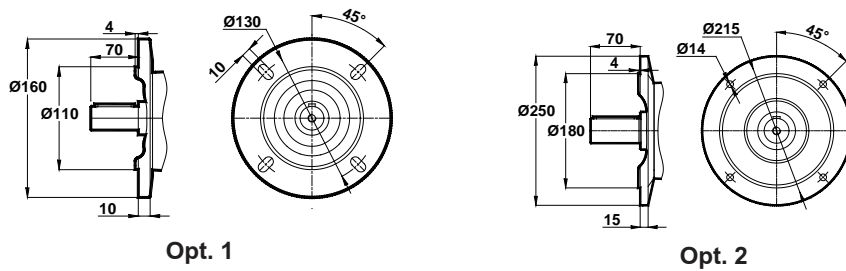

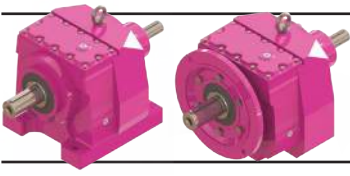

Ölçü Sayfaları Dimension Pages Abmessungenseiten



-Mil ucu çektirme deliği DIN 332 sayfa 2 / Tapped center hole to DIN 332, sheet 2 / Zentrierung mit gewinde DIN 332, Blatt 2

MT275 MT276

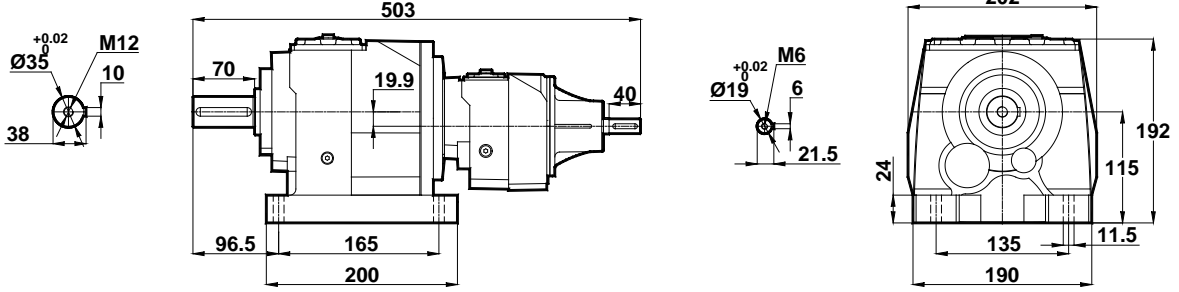

NT275 NT276

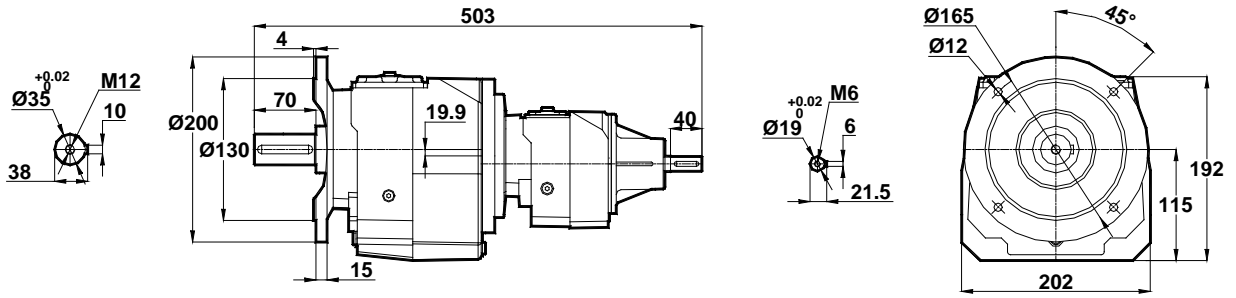

Opsiyonel Flanş Ölçüleri / Optional Flange Dimensions / Auswählbare Flanschabmessungen

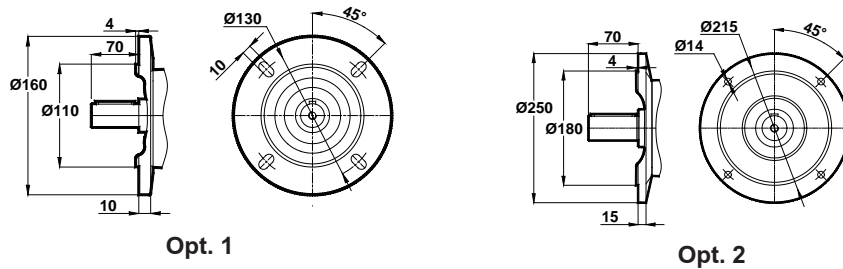

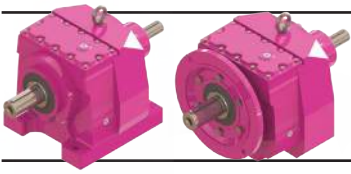

Ölçü Sayfaları Dimension Pages Abmessungsseiten



-Mil ucu çektirme deliği DIN 332 sayfa 2 / Tapped center hole to DIN 332, sheet 2 / Zentrierung mit gewinde DIN 332, Blatt 2

MT282 MT283

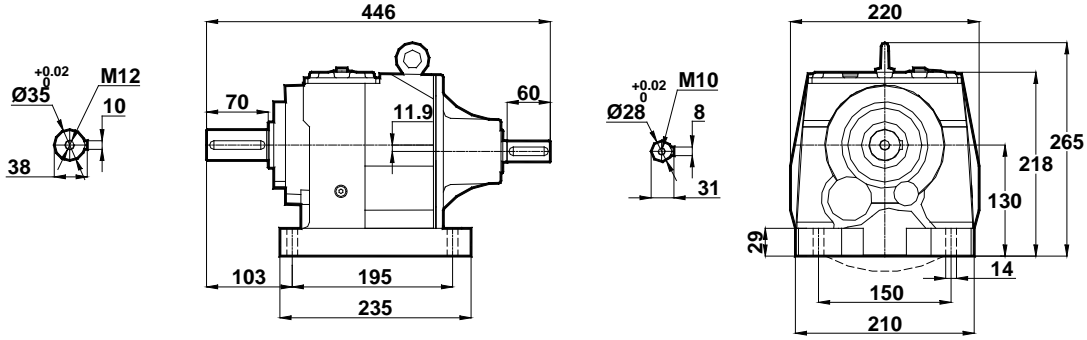

NT282 NT283

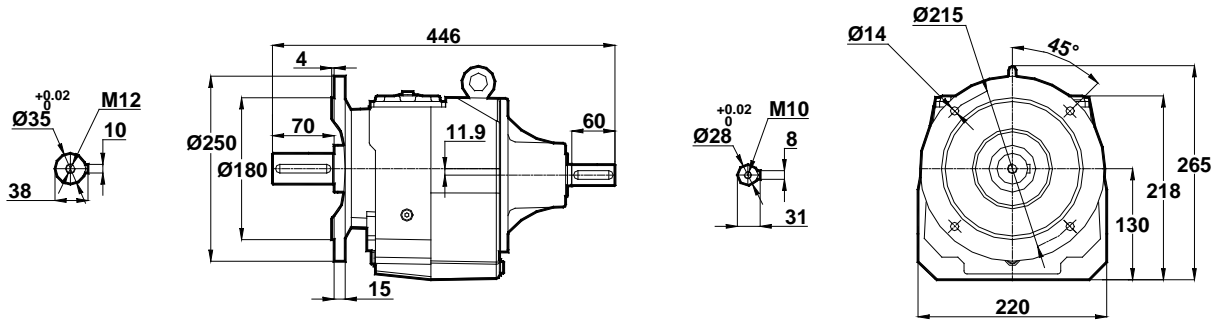

Opsiyonel Flanş Ölçüleri / Optional Flange Dimensions / Auswählbare Flanschabmessungen

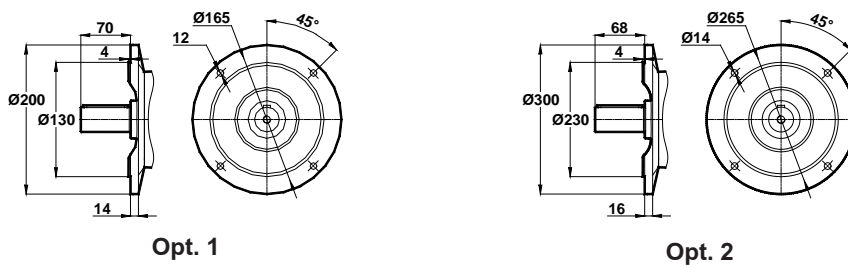

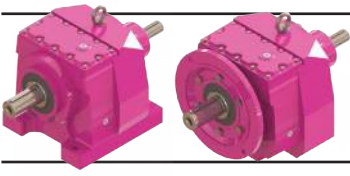

Ölçü Sayfaları Dimension Pages Abmessungenseiten



-Mil ucu çektirme deliği DIN 332 sayfa 2 / Tapped center hole to DIN 332, sheet 2 / Zentrierung mit gewinde DIN 332, Blatt 2

MT284

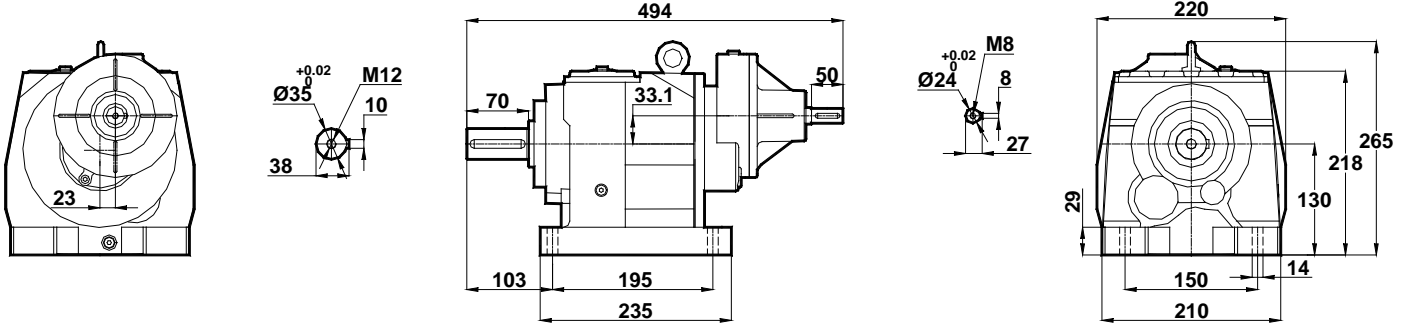

NT284

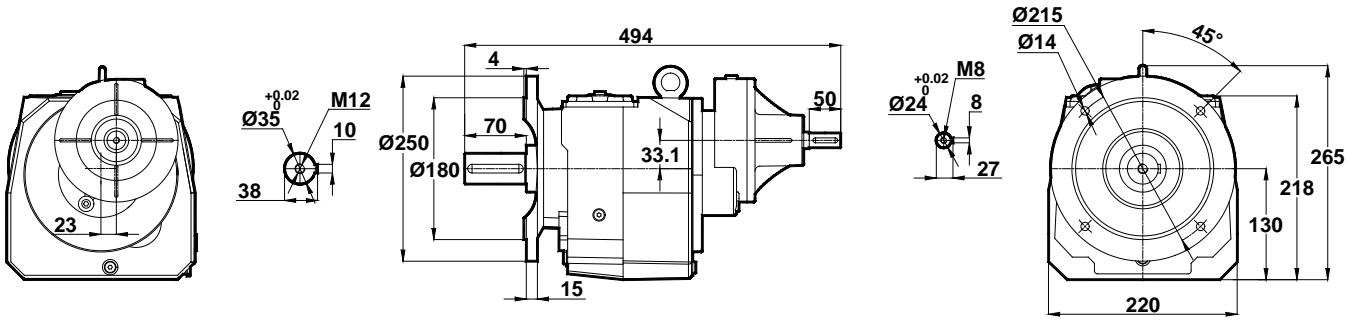

Opsiyonel Flanş Ölçüleri / Optional Flange Dimensions / Auswählbare Flanschabmessungen

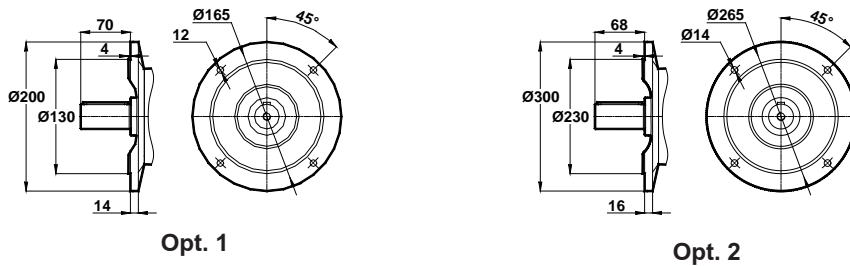

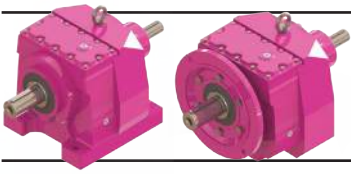

Ölçü Sayfaları Dimension Pages Abmessungsseiten



-Mil ucu çekirme deliği DIN 332 sayfa 2 / Tapped center hole to DIN 332, sheet 2 / Zentrierung mit gewinde DIN 332, Blatt 2

MT285 MT286

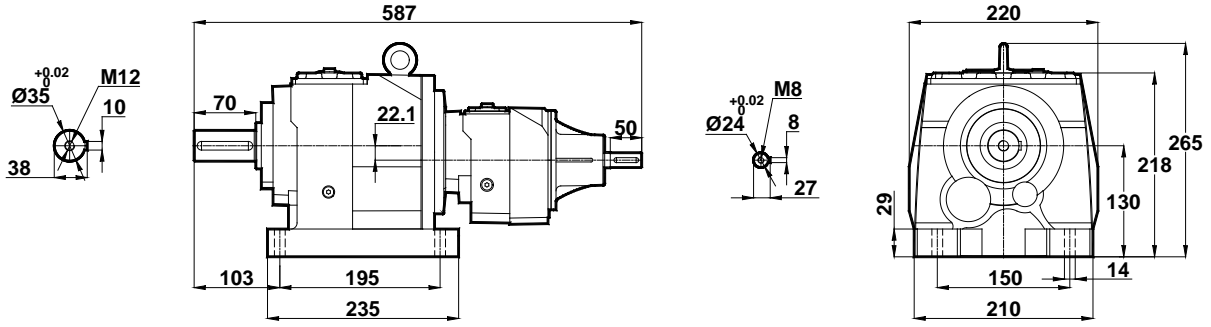

NT285 NT286

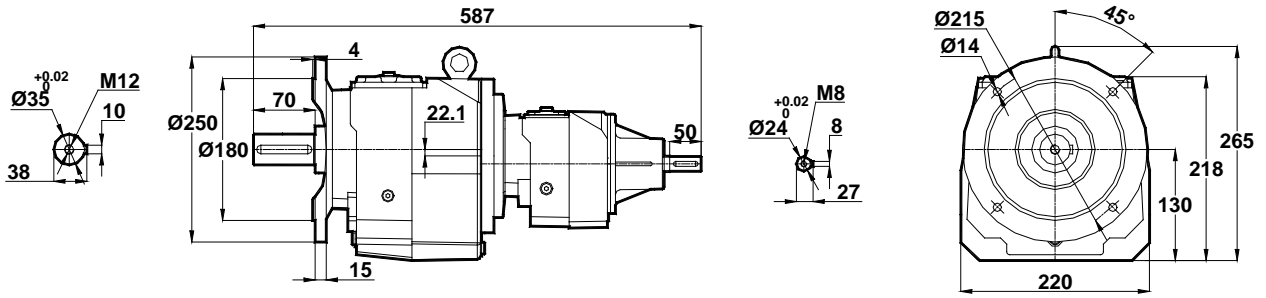

Opsiyonel Flanş Ölçüleri / Optional Flange Dimensions / Auswählbare Flanschabmessungen

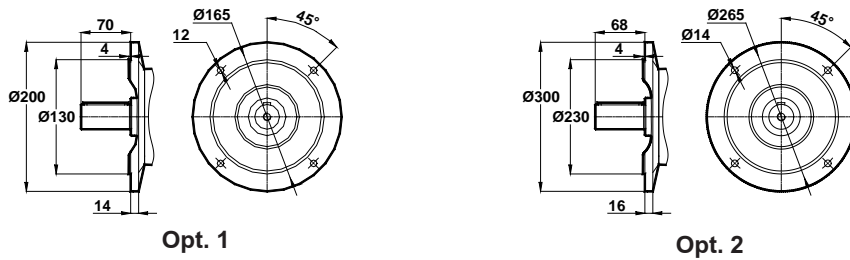

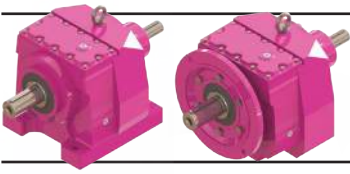

Ölçü Sayfaları Dimension Pages Abmessungenseiten



-Mil ucu çektirme deliği DIN 332 sayfa 2 / Tapped center hole to DIN 332, sheet 2 / Zentrierung mit gewinde DIN 332, Blatt 2

MT372 MT373

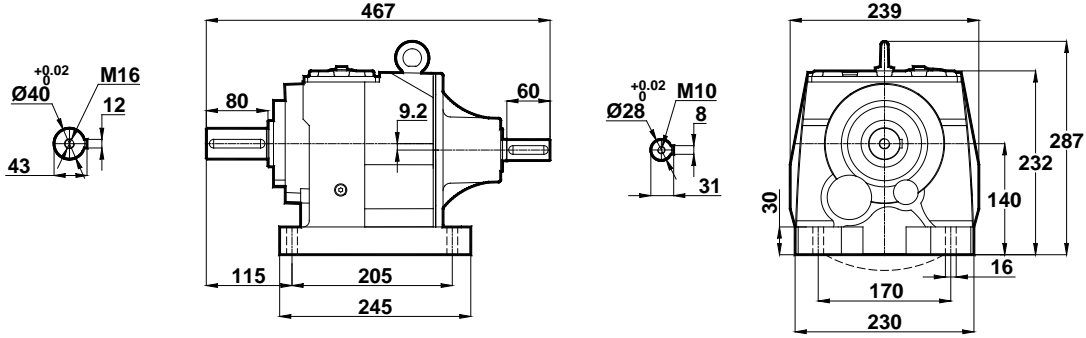

NT372 NT373

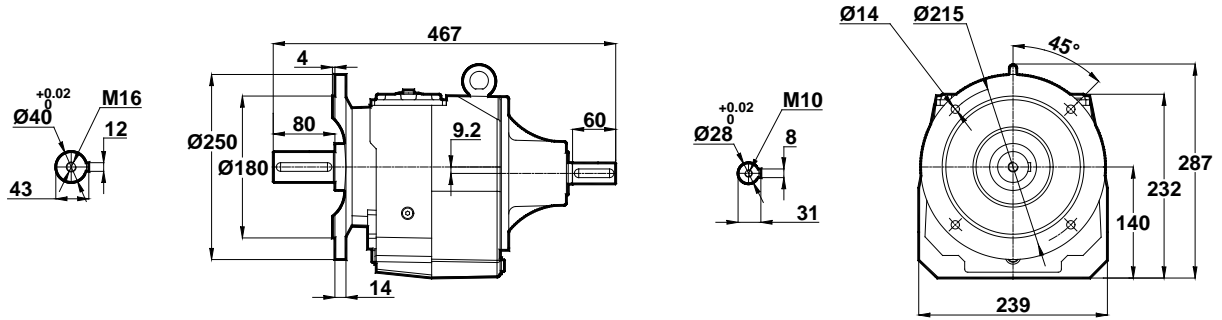

Opsiyonel Flanş Ölçüleri / Optional Flange Dimensions / Auswählbare Flanschabmessungen

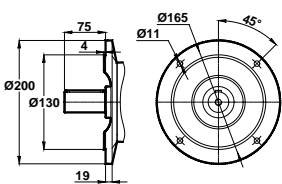

Opt. 1

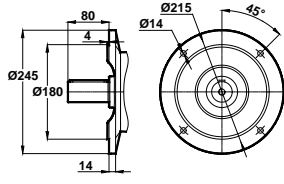

Opt. 2

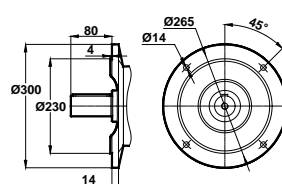

Opt. 3

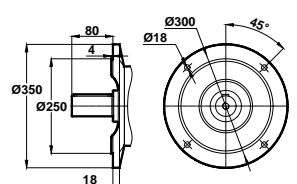

Opt. 4

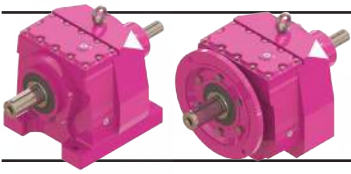

Ölçü Sayfaları Dimension Pages Abmessungsseiten



-Mil ucu çekirme deliği DIN 332 sayfa 2 / Tapped center hole to DIN 332, sheet 2 / Zentrierung mit gewinde DIN 332, Blatt 2

MT374

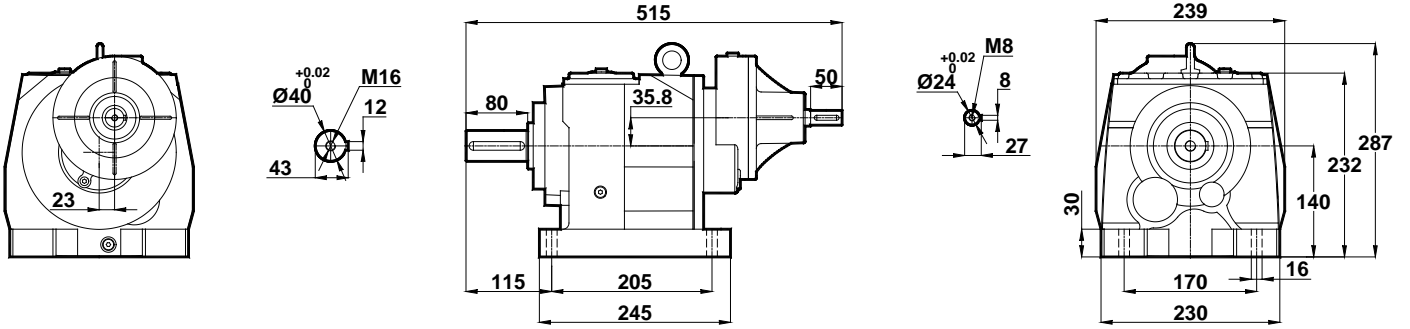

NT374

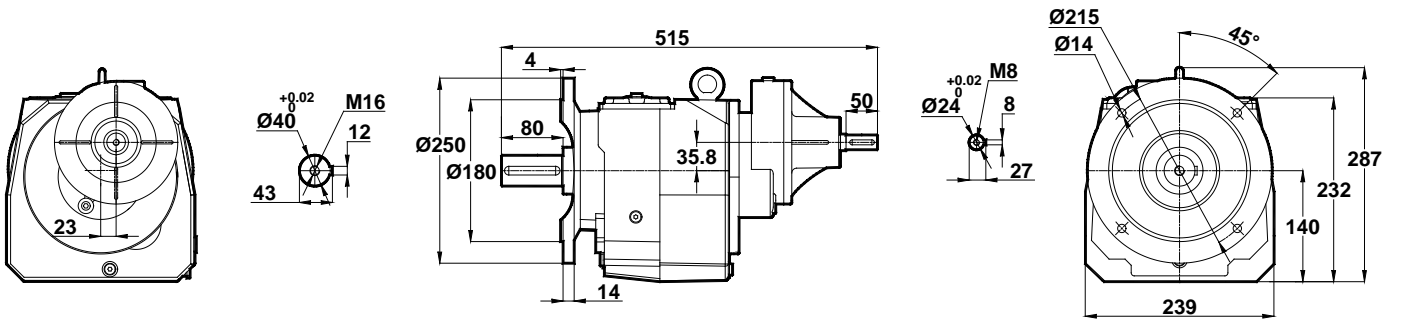

Opsiyonel Flanş Ölçüleri / Optional Flange Dimensions / Auswählbare Flanschabmessungen

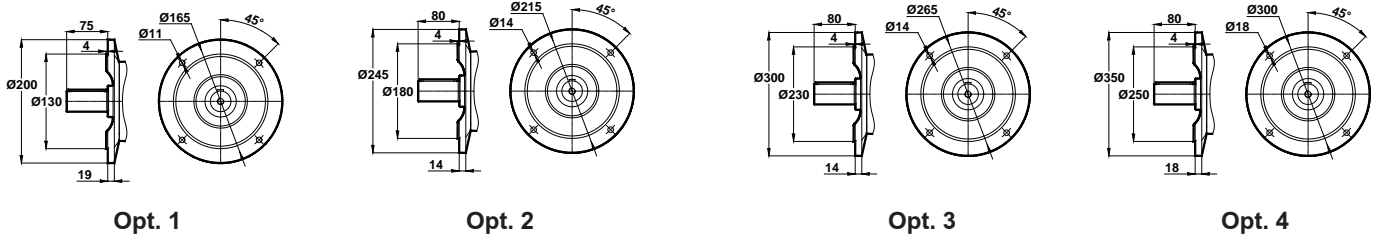

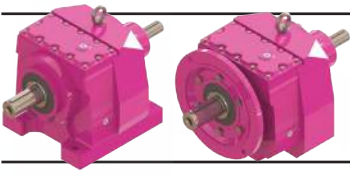

Ölçü Sayfaları Dimension Pages Abmessungenseiten



-Mil ucu çektirme deliği DIN 332 sayfa 2 / Tapped center hole to DIN 332, sheet 2 / Zentrierung mit gewinde DIN 332, Blatt 2

MT375 MT376

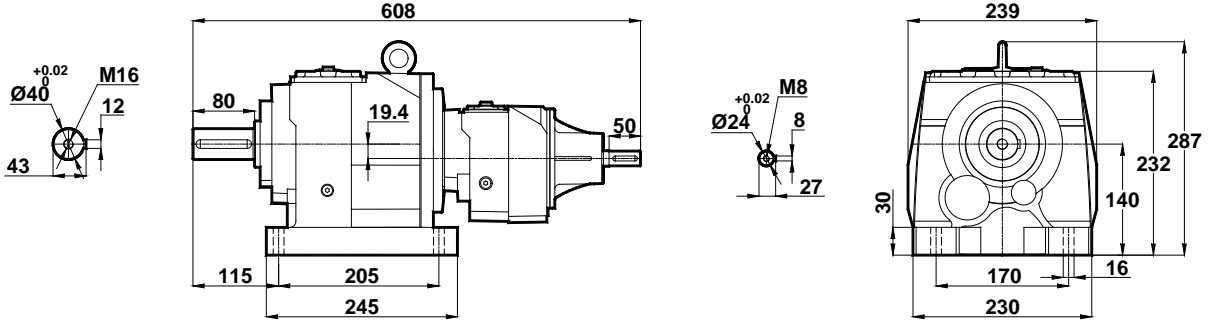

NT375 NT376

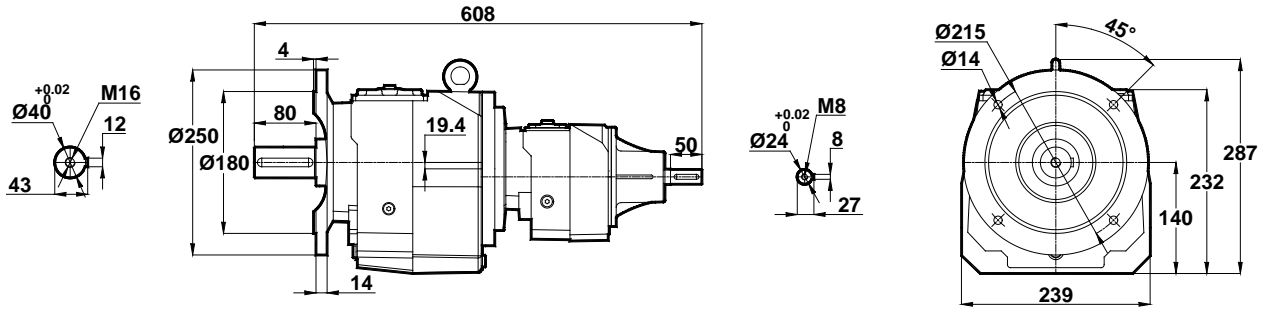

Opsiyonel Flanş Ölçüleri / Optional Flange Dimensions / Auswählbare Flanschabmessungen

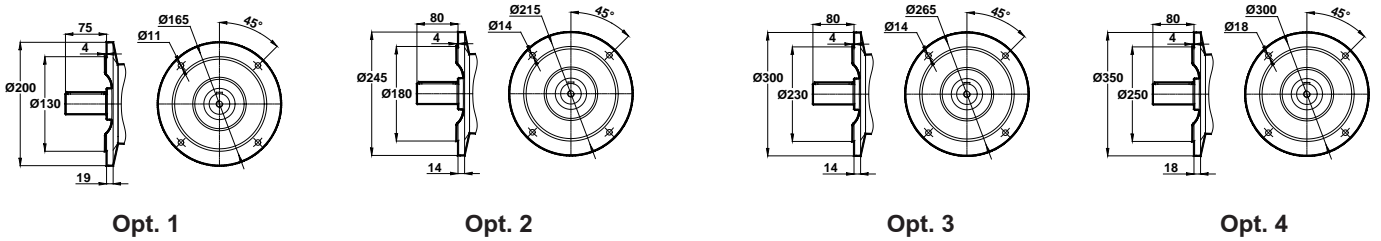

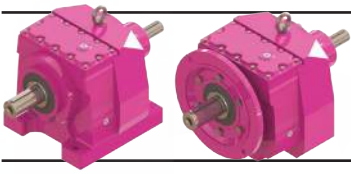

Ölçü Sayfaları Dimension Pages Abmessungenseiten



-Mil ucu çekirme deliği DIN 332 sayfa 2 / Tapped center hole to DIN 332, sheet 2 / Zentrierung mit gewinde DIN 332, Blatt 2

MT472 MT473

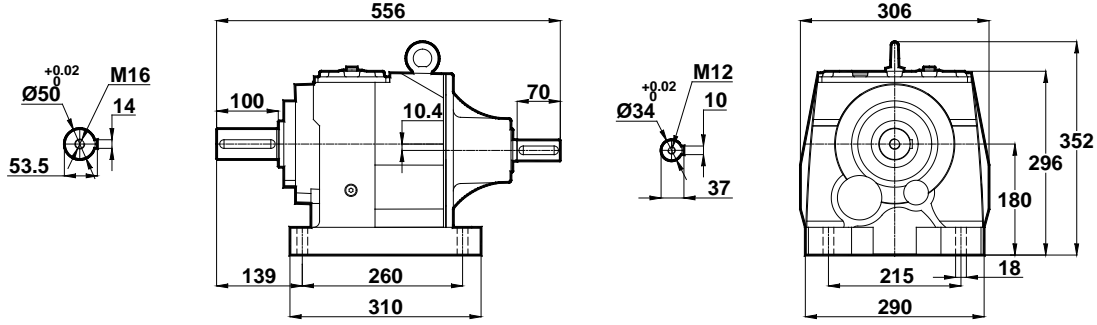

NT472 NT473

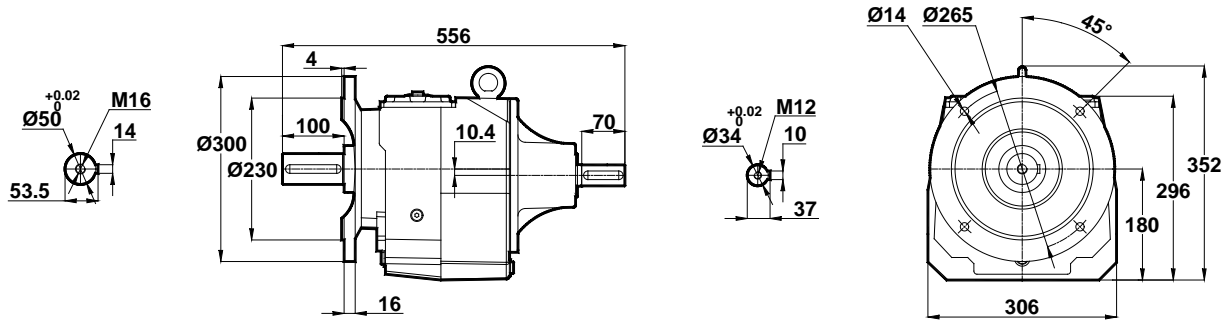

Opsiyonel Flanş Ölçüleri / Optional Flange Dimensions / Auswählbare Flanschabmessungen

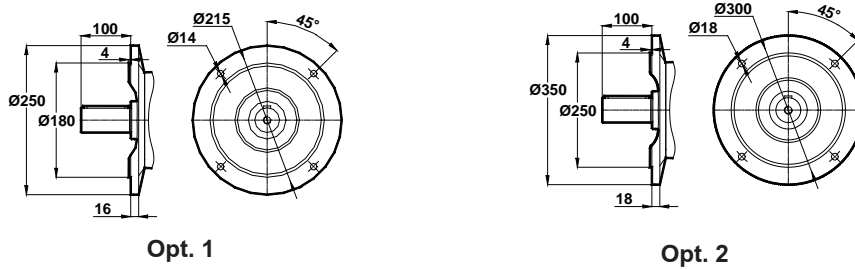

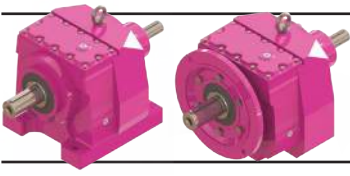

Ölçü Sayfaları Dimension Pages Abmessungenseiten



-Mil ucu çektirme deliği DIN 332 sayfa 2 / Tapped center hole to DIN 332, sheet 2 / Zentrierung mit gewinde DIN 332, Blatt 2

MT474

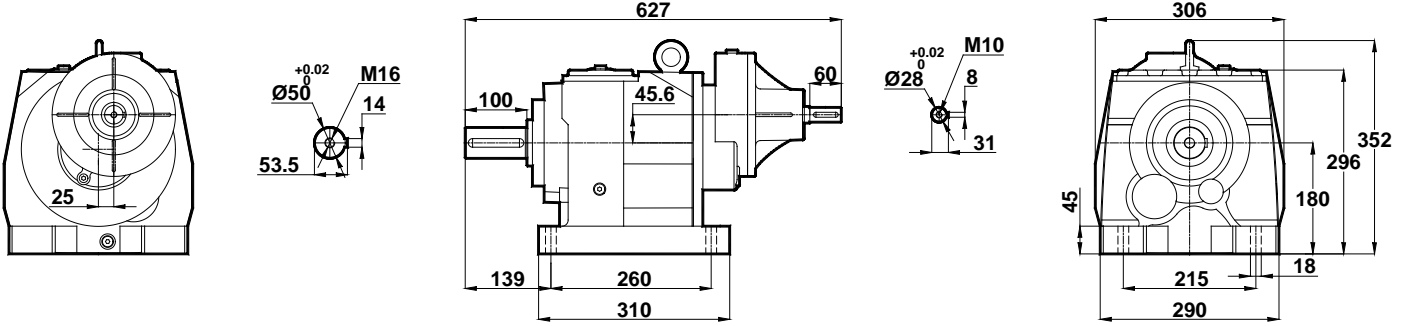

NT474

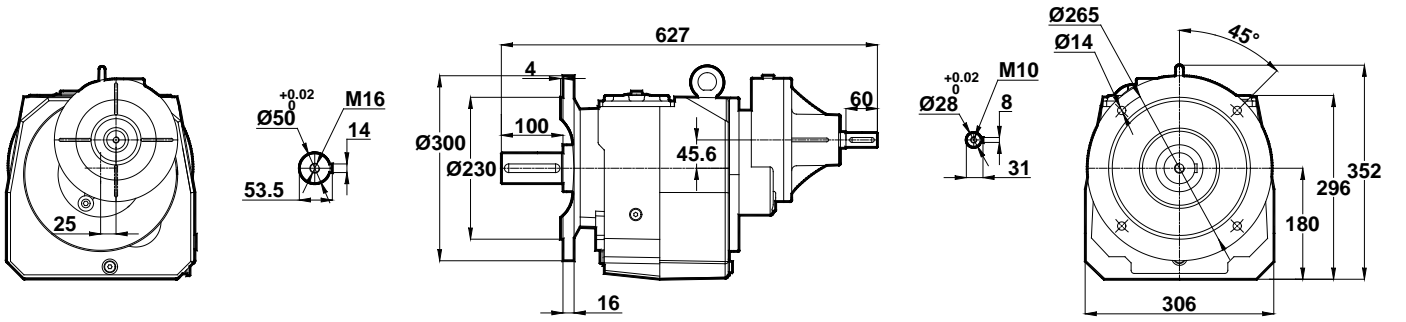

Opsiyonel Flanş Ölçüleri / Optional Flange Dimensions / Auswählbare Flanschabmessungen

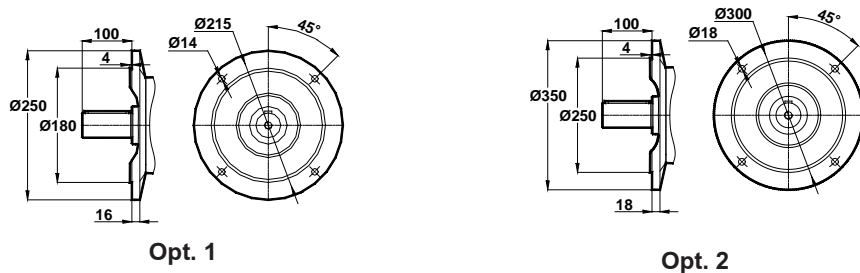

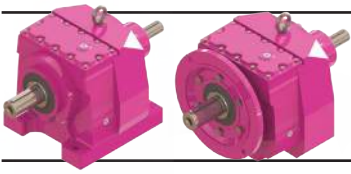

Ölçü Sayfaları Dimension Pages Abmessungsseiten



-Mil ucu çekirme deliği DIN 332 sayfa 2 / Tapped center hole to DIN 332, sheet 2 / Zentrierung mit gewinde DIN 332, Blatt 2

MT475 MT476

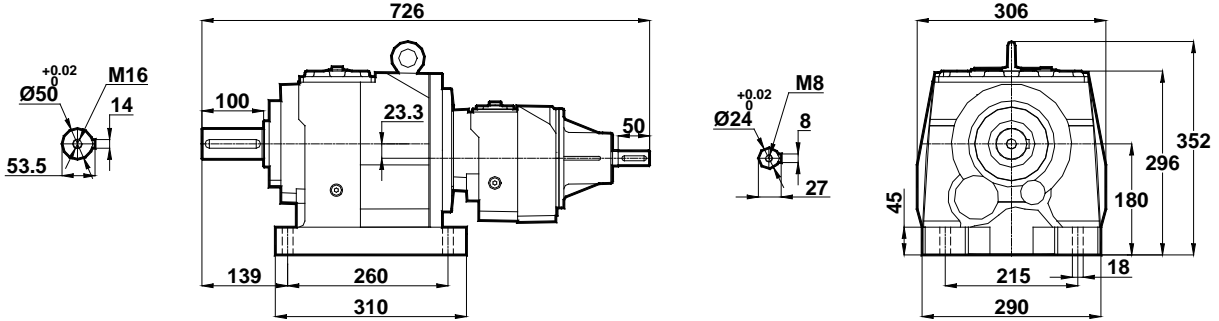

NT475 NT476

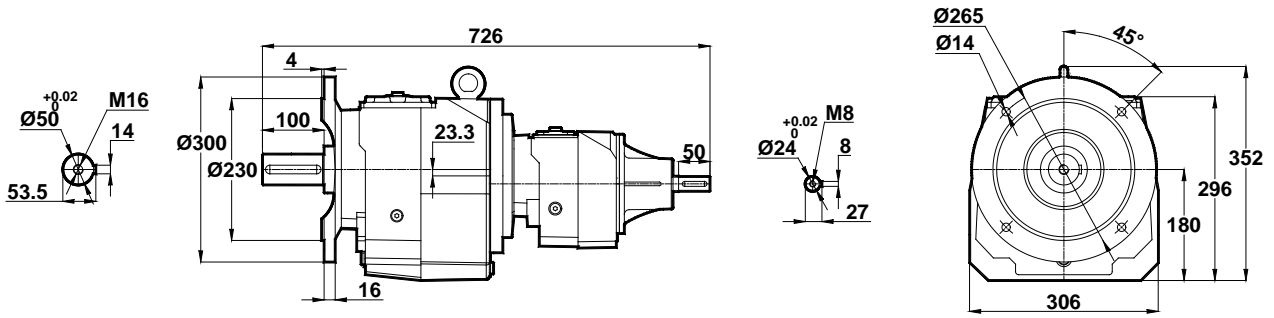

Opsiyonel Flanş Ölçüleri / Optional Flange Dimensions / Auswählbare Flanschabmessungen

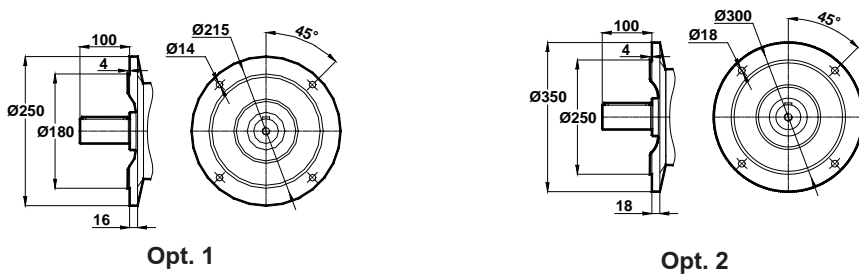

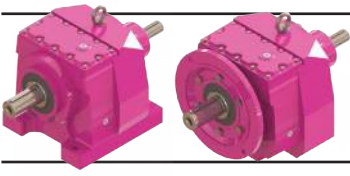

Ölçü Sayfaları Dimension Pages Abmessungenseiten



-Mil ucu çektirme deliği DIN 332 sayfa 2 / Tapped center hole to DIN 332, sheet 2 / Zentrierung mit gewinde DIN 332, Blatt 2

MT572 MT573

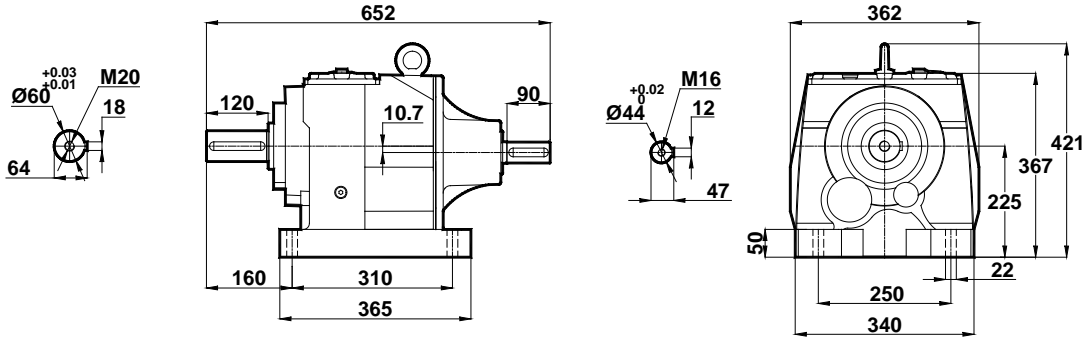

NT572 NT573

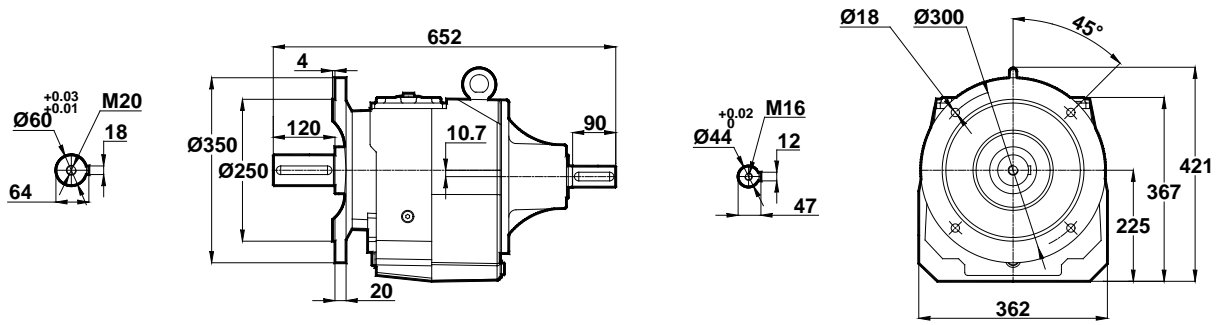

Opsiyonel Flanş Ölçüleri / Optional Flange Dimensions / Auswählbare Flanschabmessungen

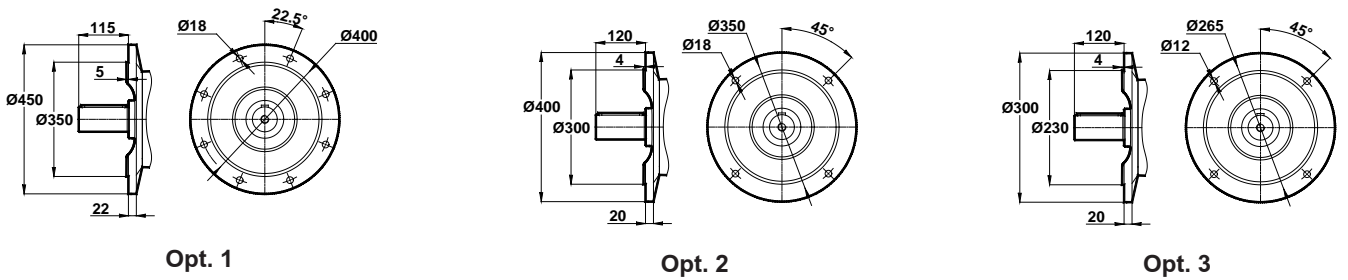

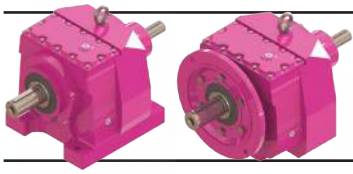

Ölçü Sayfaları Dimension Pages Abmessungsseiten



-Mil ucu çekirme deliği DIN 332 sayfa 2 / Tapped center hole to DIN 332, sheet 2 / Zentrierung mit gewinde DIN 332, Blatt 2

MT574

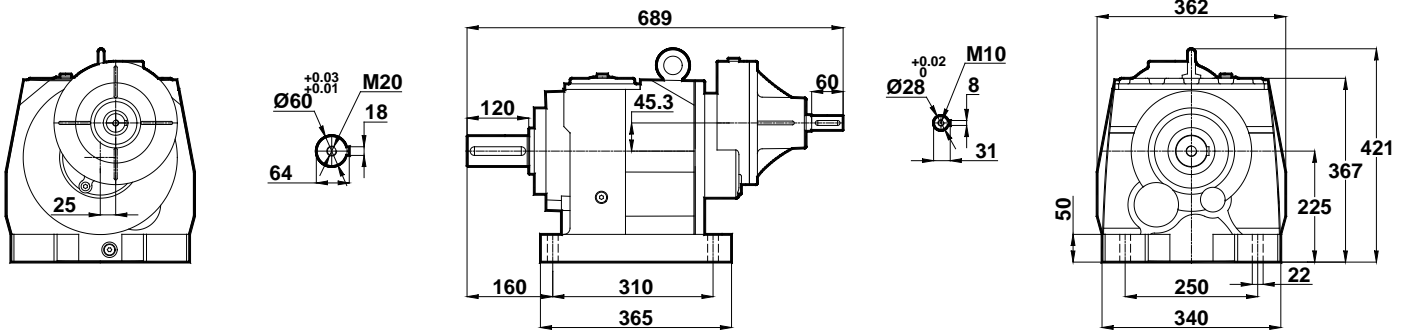

NT574

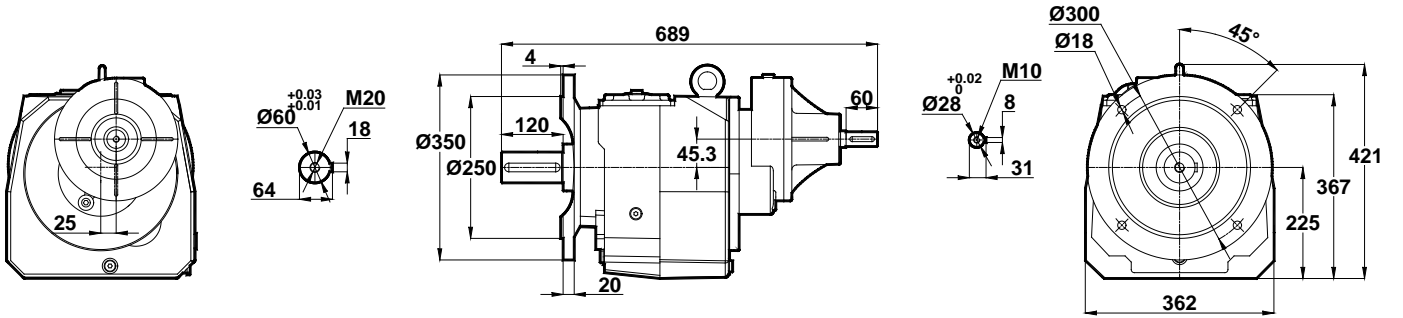

Opsiyonel Flanş Ölçüleri / Optional Flange Dimensions / Auswählbare Flanschabmessungen

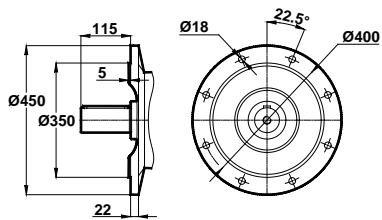

Opt. 1

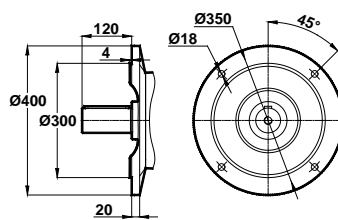

Opt. 2

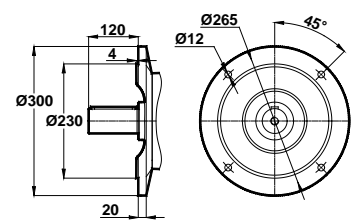

Opt. 3

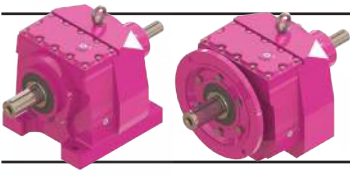

Ölçü Sayfaları Dimension Pages Abmessungenseiten



-Mil ucu çektirme deliği DIN 332 sayfa 2 / Tapped center hole to DIN 332, sheet 2 / Zentrierung mit gewinde DIN 332, Blatt 2

MT575 MT576

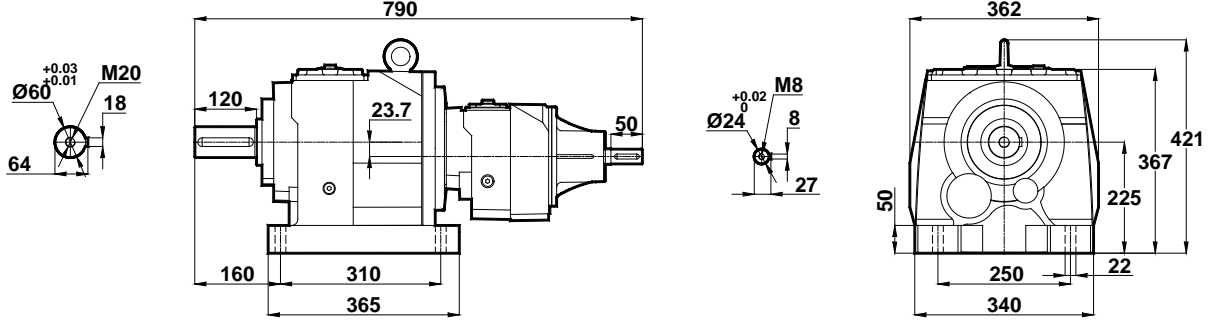

NT575 NT576

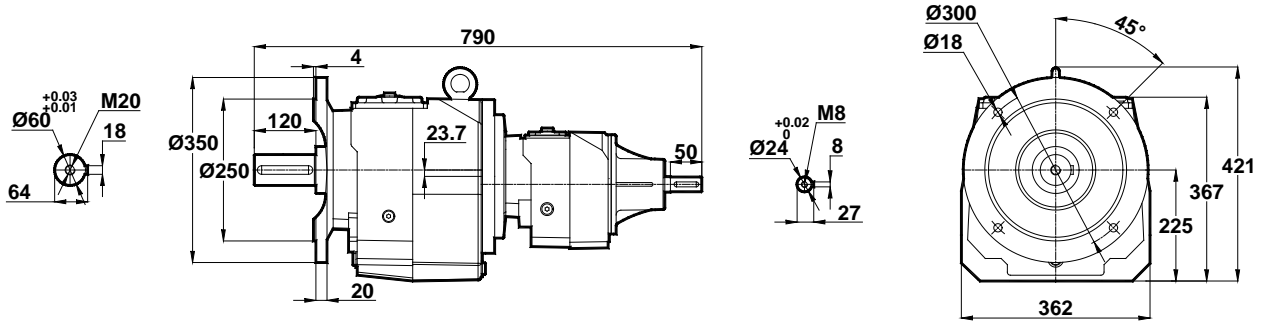

Opsiyonel Flanş Ölçüleri / Optional Flange Dimensions / Auswählbare Flanschabmessungen

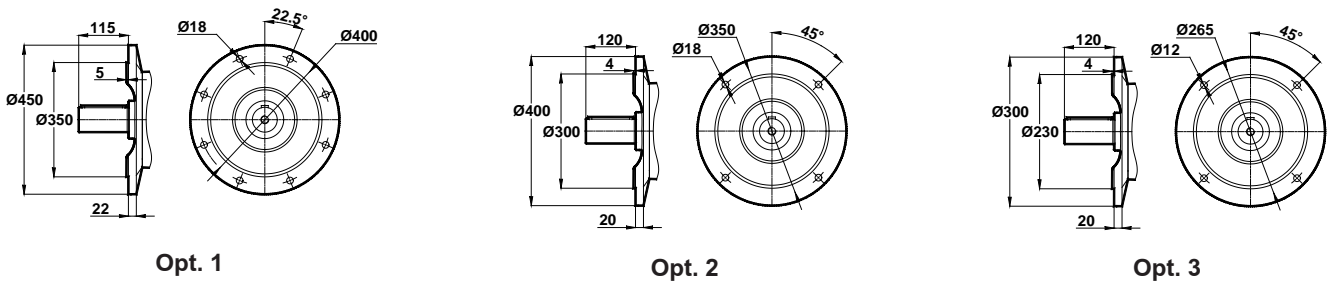

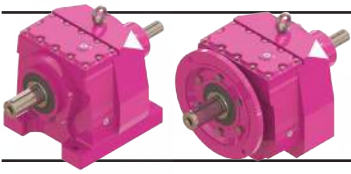

Ölçü Sayfaları Dimension Pages Abmessungenseiten



-Mil ucu çektirme deliği DIN 332 sayfa 2 / Tapped center hole to DIN 332, sheet 2 / Zentrierung mit gewinde DIN 332, Blatt 2

MT672 MT673

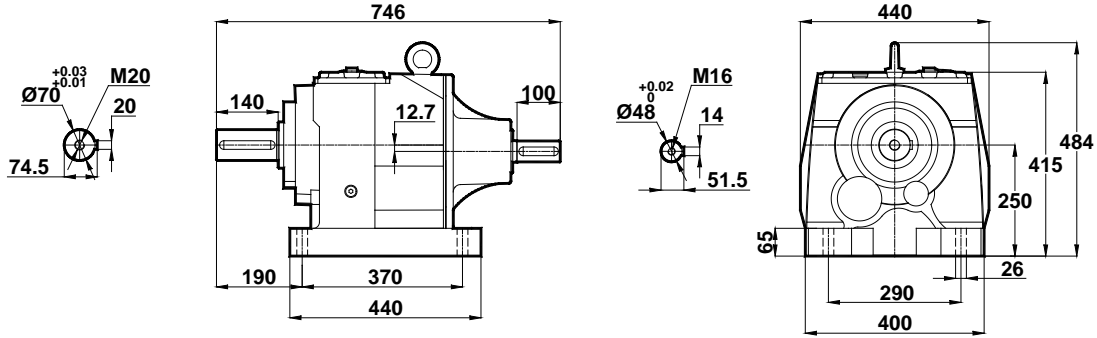

NT672 NT673

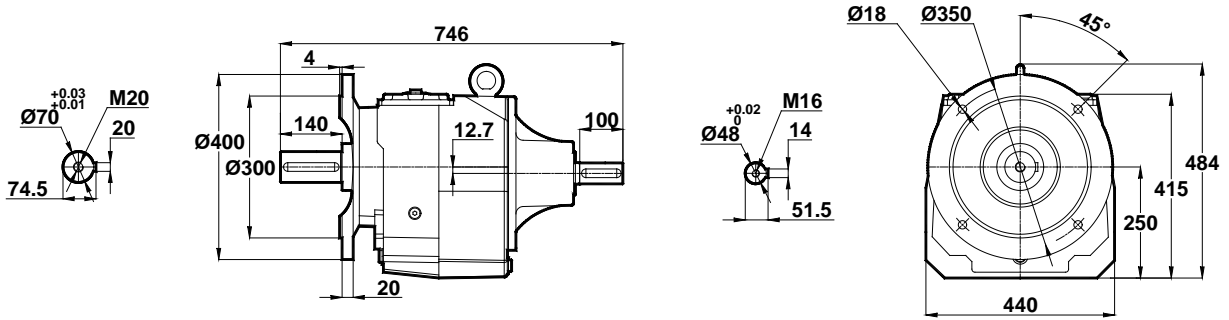

Opsiyonel Flanş Ölçüleri / Optional Flange Dimensions / Auswählbare Flanschabmessungen

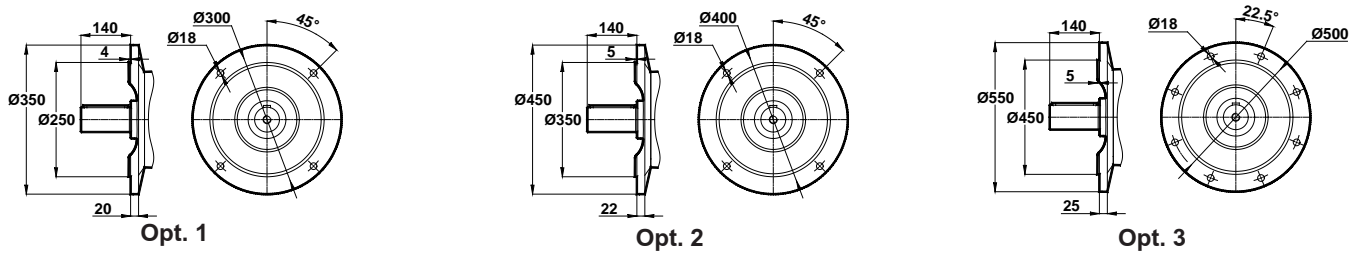

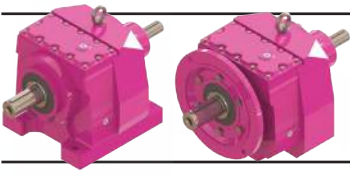

Ölçü Sayfaları Dimension Pages Abmessungsseiten



-Mil ucu çektirme deliği DIN 332 sayfa 2 / Tapped center hole to DIN 332, sheet 2 / Zentrierung mit gewinde DIN 332, Blatt 2

MT674

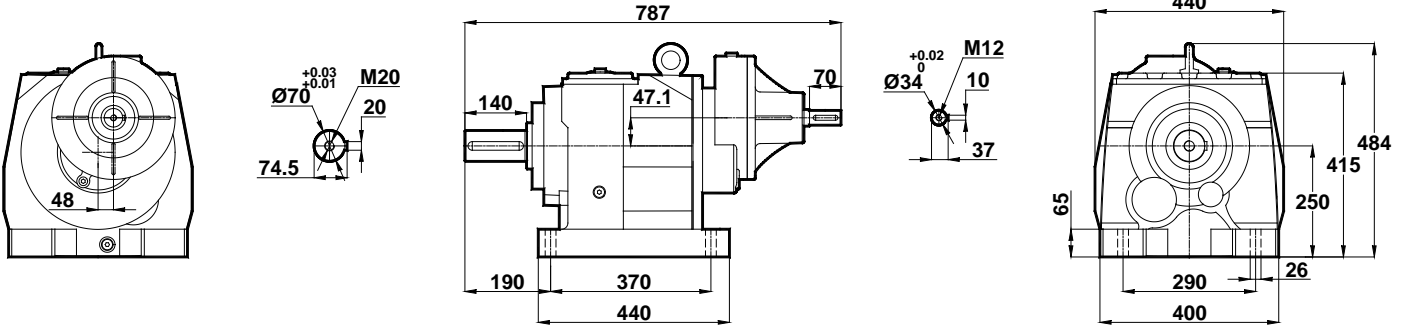

NT674

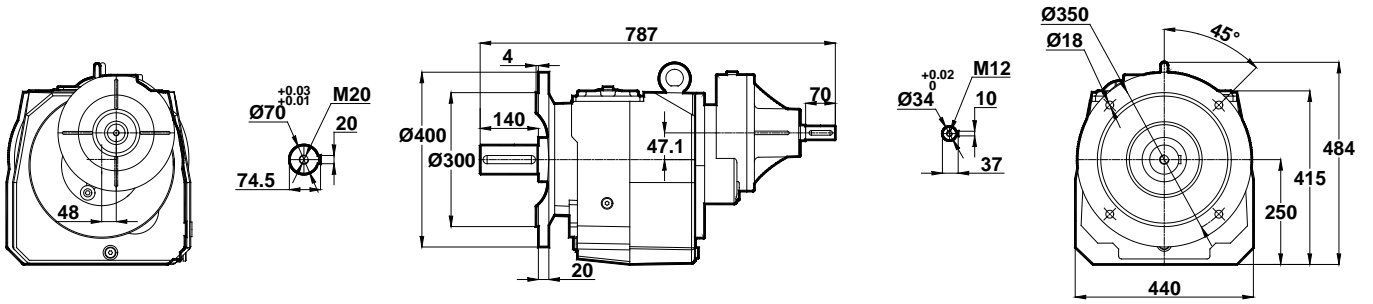

Opsiyonel Flanş Ölçüleri / Optional Flange Dimensions / Auswählbare Flanschabmessungen

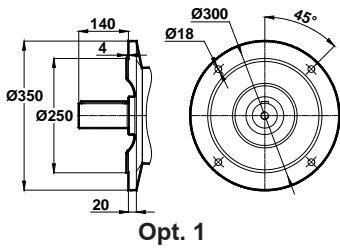

Opt. 1

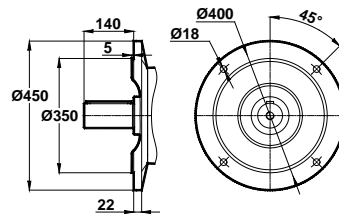

Opt. 2

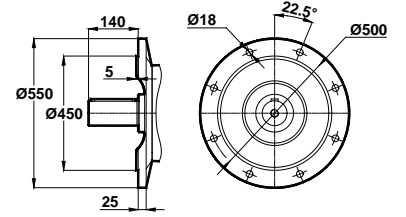

Opt. 3

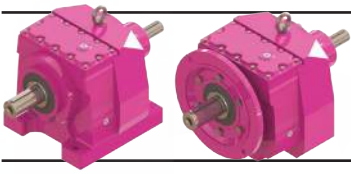

Ölçü Sayfaları Dimension Pages Abmessungsseiten



-Mil ucu çekirme deliği DIN 332 sayfa 2 / Tapped center hole to DIN 332, sheet 2 / Zentrierung mit gewinde DIN 332, Blatt 2

MT675 MT676

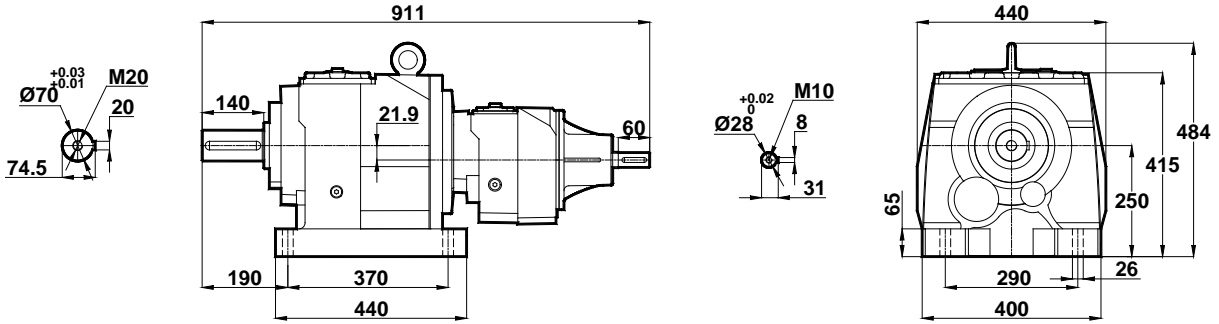

NT675 NT676

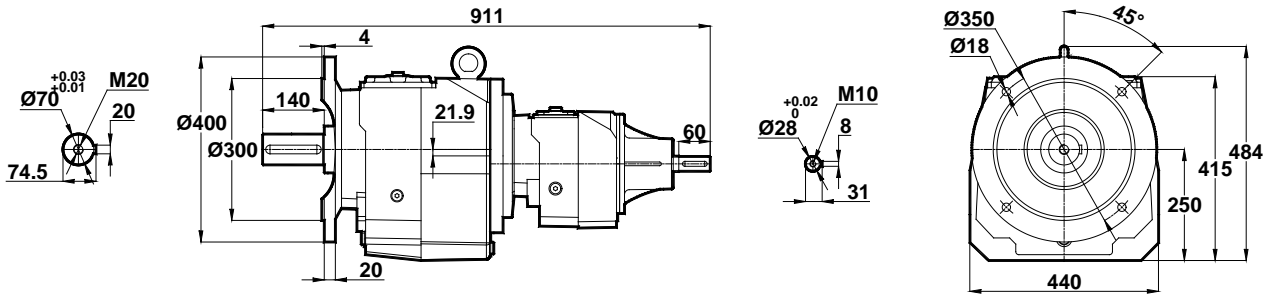

Opsiyonel Flanş Ölçüleri / Optional Flange Dimensions / Auswählbare Flanschabmessungen

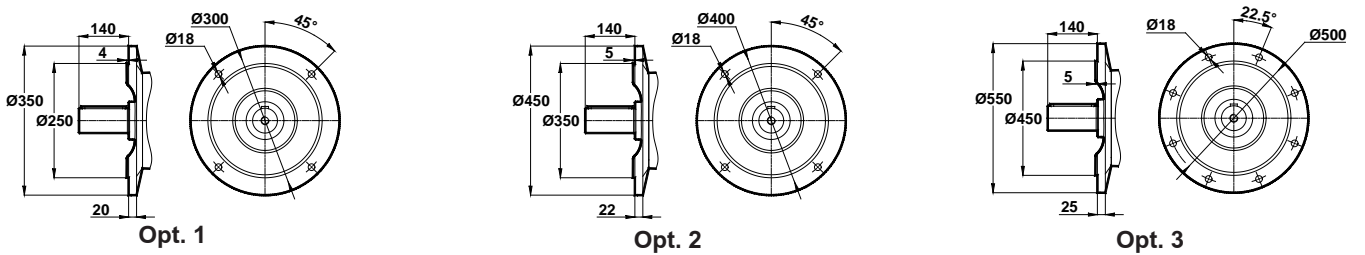

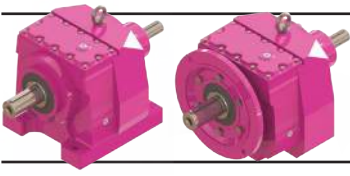

Ölçü Sayfaları Dimension Pages Abmessungsseiten



-Mil ucu çektirme deliği DIN 332 sayfa 2 / Tapped center hole to DIN 332, sheet 2 / Zentrierung mit gewinde DIN 332, Blatt 2

**MT772
MT773**

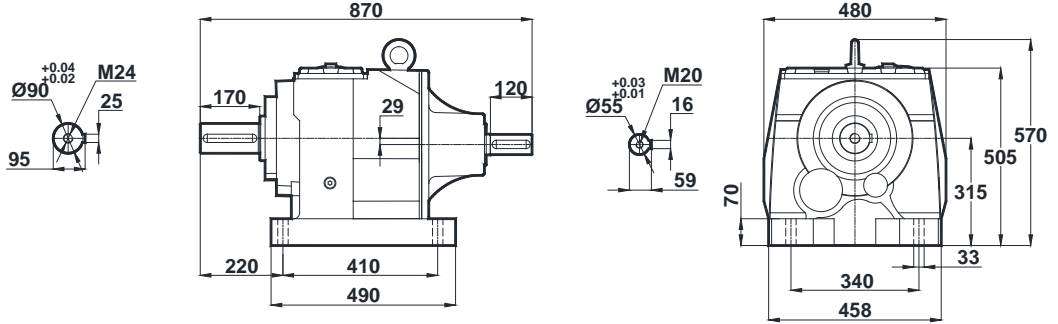

**NT772
NT773**

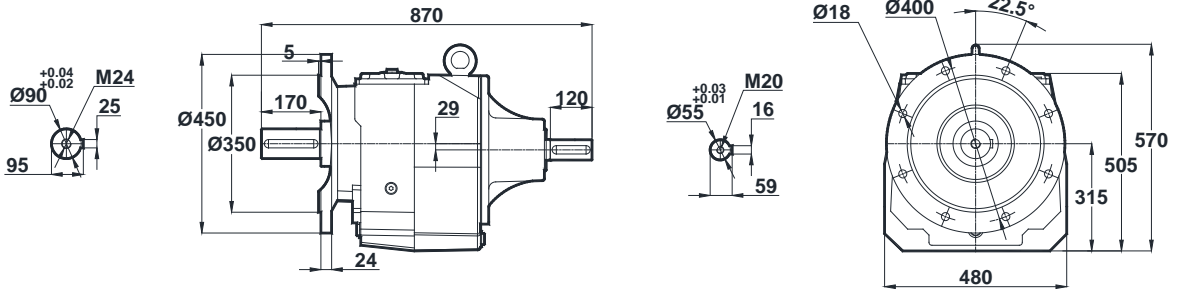

Opsiyonel Flanş Ölçüleri / Optional Flange Dimensions / Auswählbare Flanschabmessungen

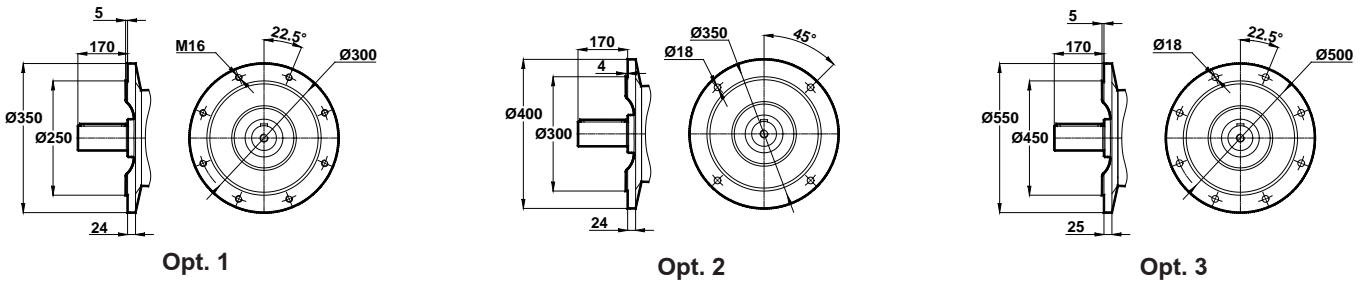

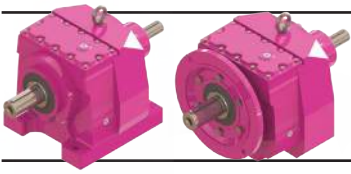

Ölçü Sayfaları Dimension Pages Abmessungsseiten



-Mil ucu çektirme deliği DIN 332 sayfa 2 / Tapped center hole to DIN 332, sheet 2 / Zentrierung mit gewinde DIN 332, Blatt 2

MT774

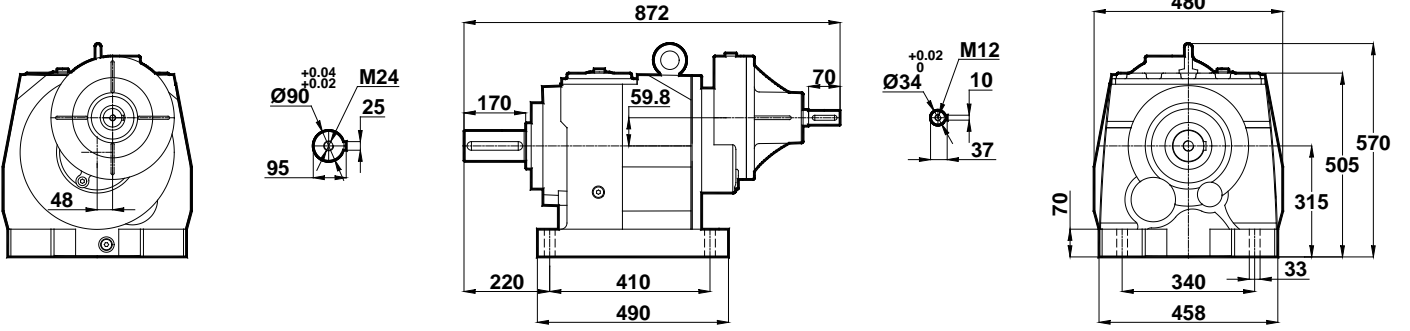

NT774

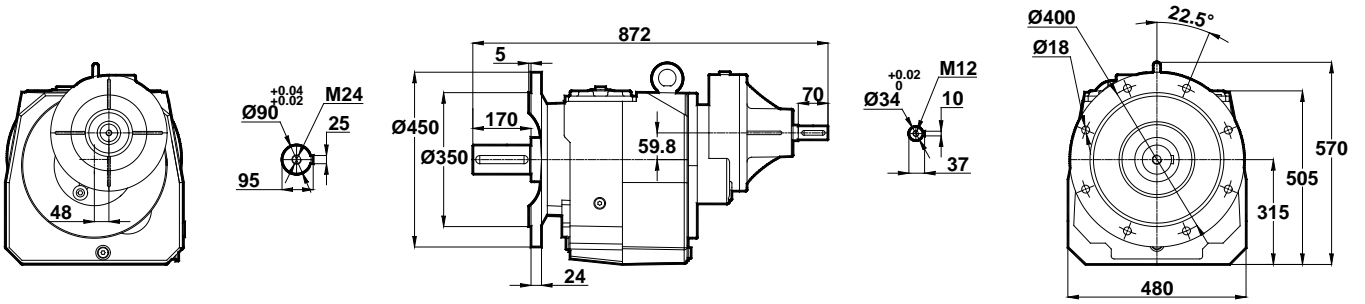

Opsiyonel Flanş Ölçüleri / Optional Flange Dimensions / Auswählbare Flanschabmessungen

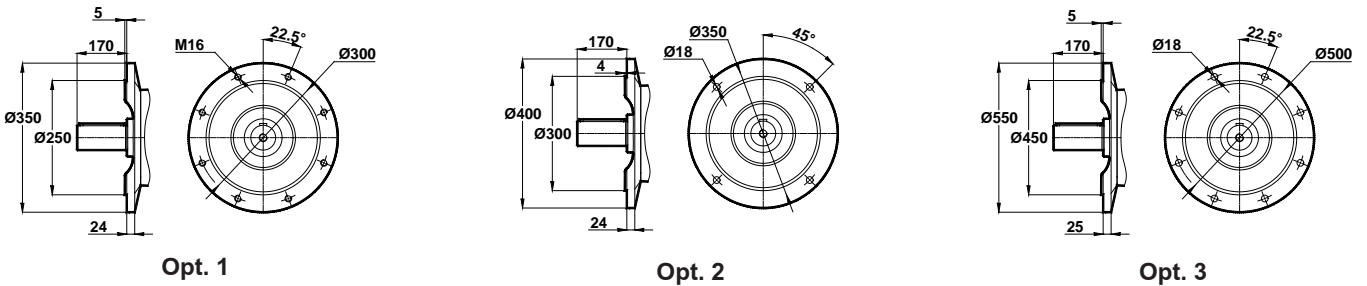

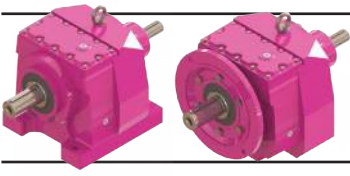

Ölçü Sayfaları Dimension Pages Abmessungenseiten



-Mil ucu çektirme deliği DIN 332 sayfa 2 / Tapped center hole to DIN 332, sheet 2 / Zentrierung mit gewinde DIN 332, Blatt 2

MT775 MT776

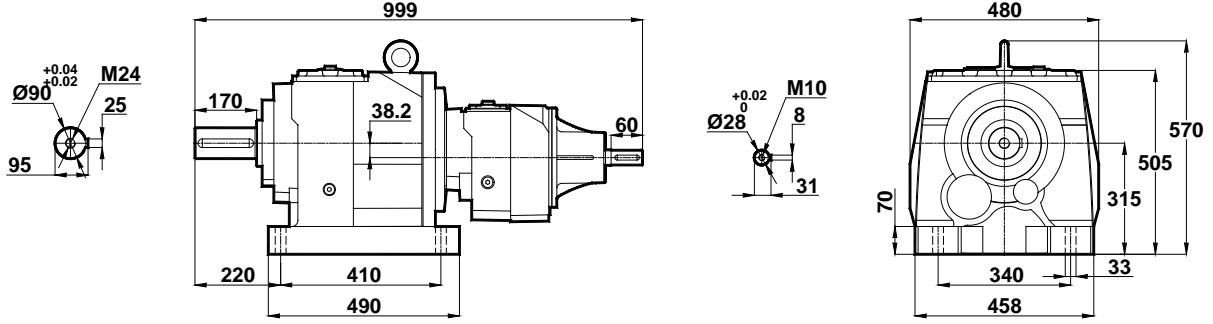

NT775 NT776

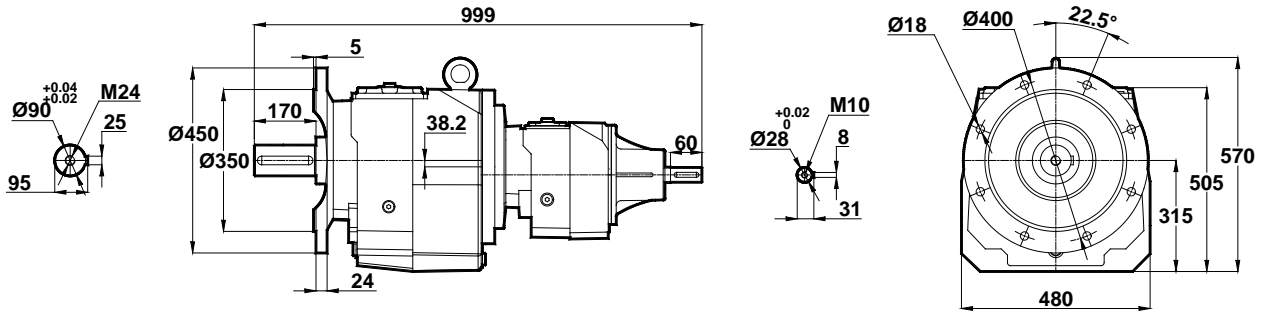

Opsiyonel Flanş Ölçüleri / Optional Flange Dimensions / Auswählbare Flanschabmessungen

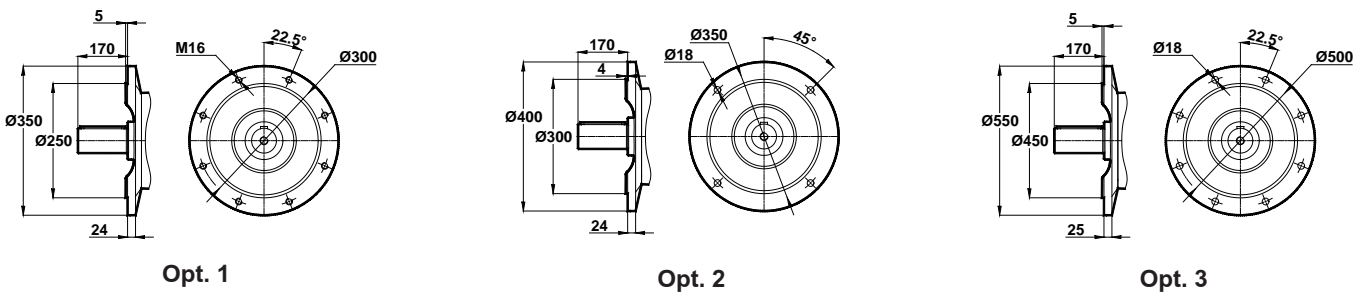

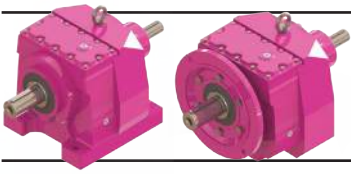

Ölçü Sayfaları Dimension Pages Abmessungenseiten



-Mil ucu çektirme deliği DIN 332 sayfa 2 / Tapped center hole to DIN 332, sheet 2 / Zentrierung mit gewinde DIN 332, Blatt 2

MT872 MT873

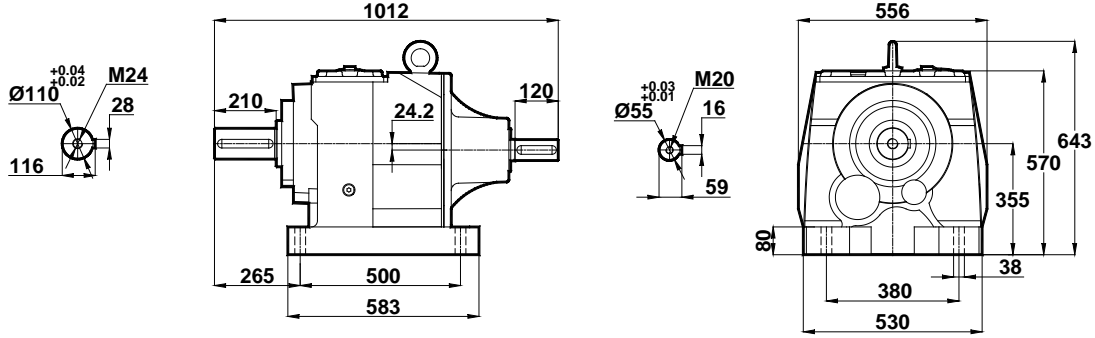

NT872 NT873

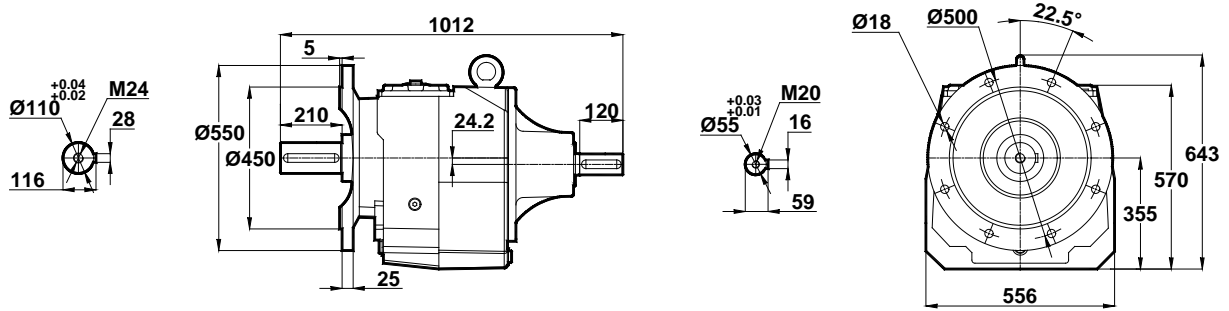

Opsiyonel Flanş Ölçüleri / Optional Flange Dimensions / Auswählbare Flanschabmessungen

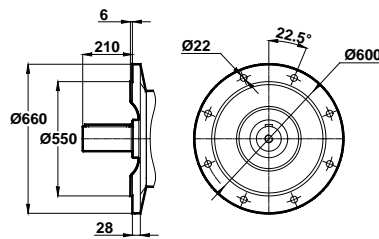

Opt. 1

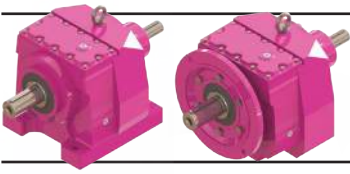

Ölçü Sayfaları Dimension Pages Abmessungsseiten



-Mil ucu çektirme deliği DIN 332 sayfa 2 / Tapped center hole to DIN 332, sheet 2 / Zentrierung mit gewinde DIN 332, Blatt 2

MT874

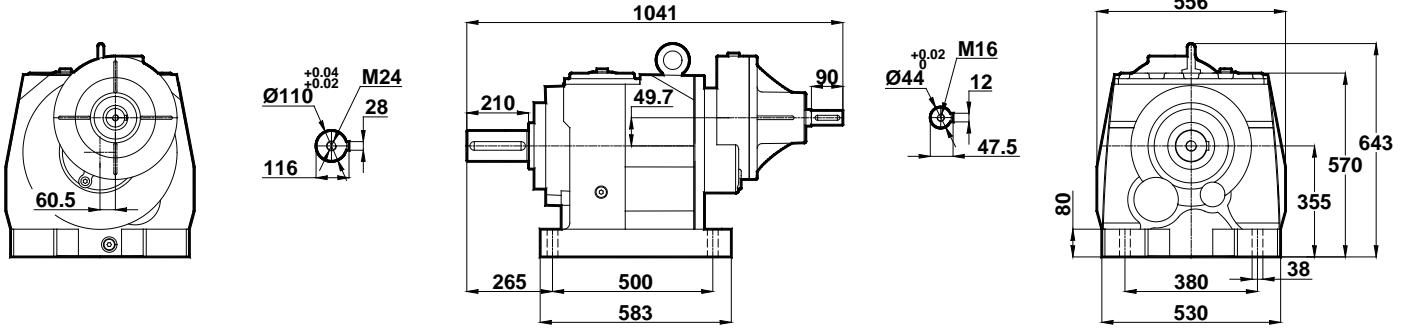

NT874

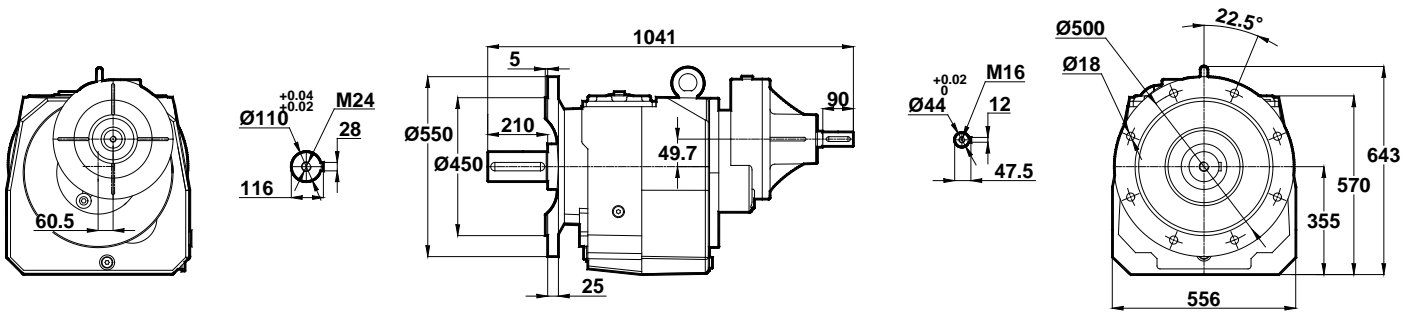

Opsiyonel Flanş Ölçüleri / Optional Flange Dimensions / Auswählbare Flanschabmessungen

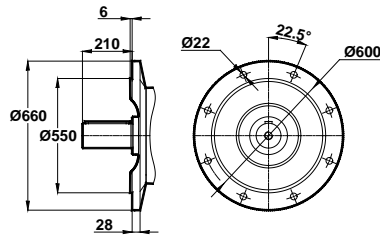

Opt. 1

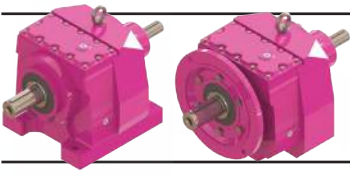

Ölçü Sayfaları

Dimension Pages

Abmessungsseiten



-Mil ucu çektirme deliği DIN 332 sayfa 2 / Tapped center hole to DIN 332, sheet 2 / Zentrierung mit gewinde DIN 332, Blatt 2

MT972

MT973

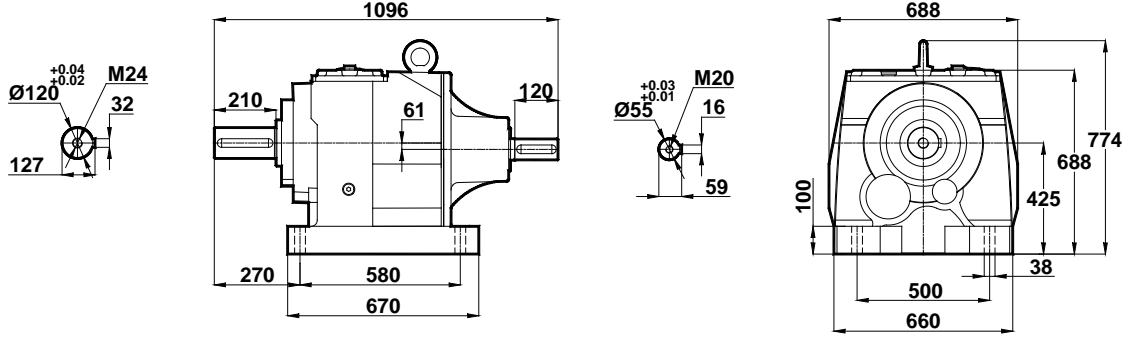

NT972

NT973

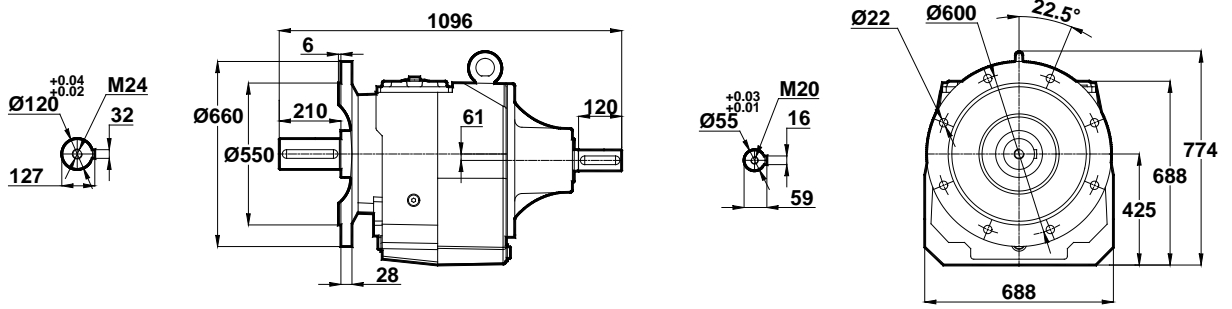

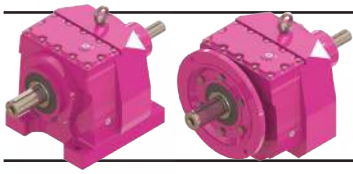

Ölçü Sayfaları

Dimension Pages

Abmessungsseiten



-Mil ucu çektirme deliği DIN 332 sayfa 2 / Tapped center hole to DIN 332, sheet 2 / Zentrierung mit gewinde DIN 332, Blatt 2

MT974

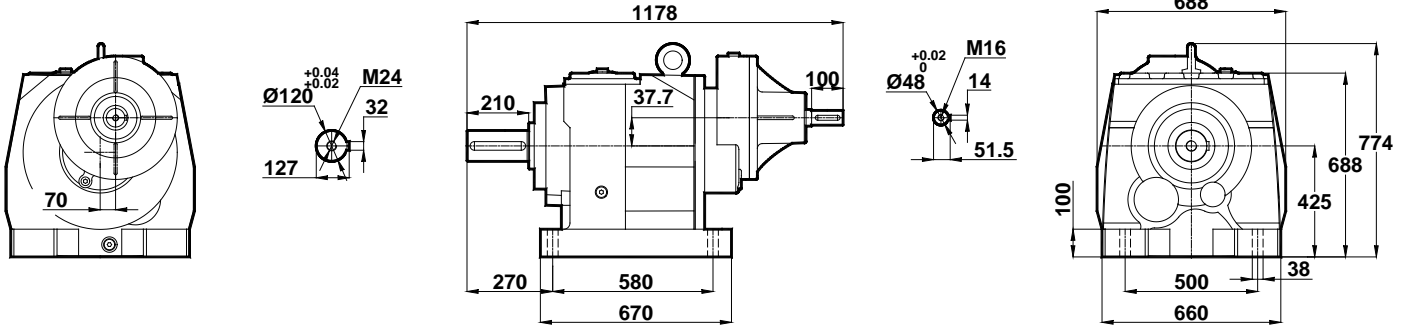

NT974

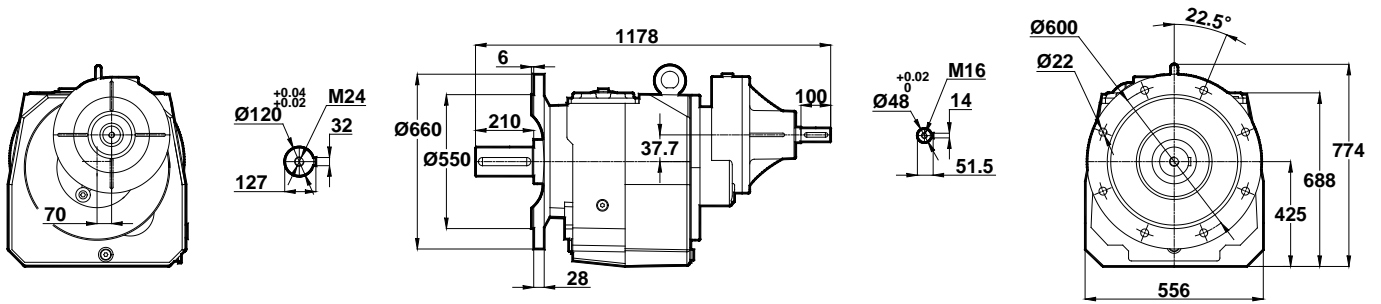

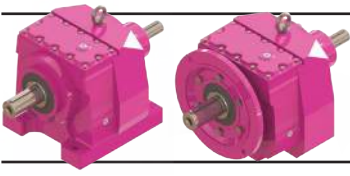

Ölçü Sayfaları

Dimension Pages

Abmessungsseiten



-Mil ucu çektirme deliği DIN 332 sayfa 2 / Tapped center hole to DIN 332, sheet 2 / Zentrierung mit gewinde DIN 332, Blatt 2

MT975

MT976

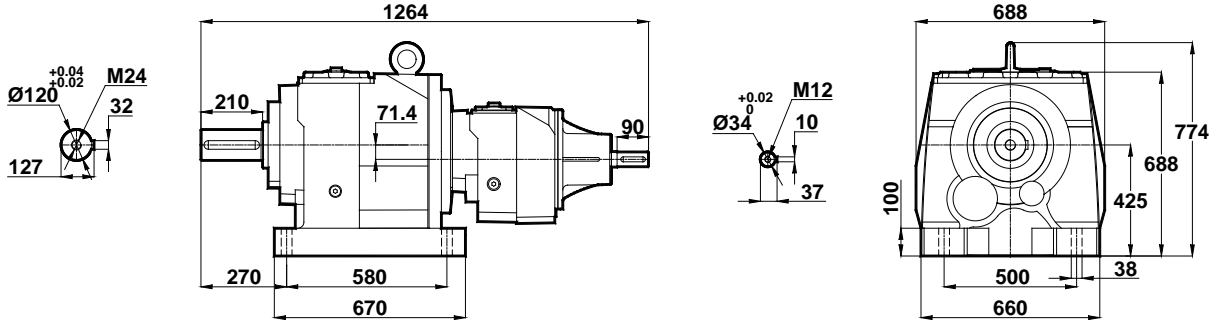

NT975

NT976

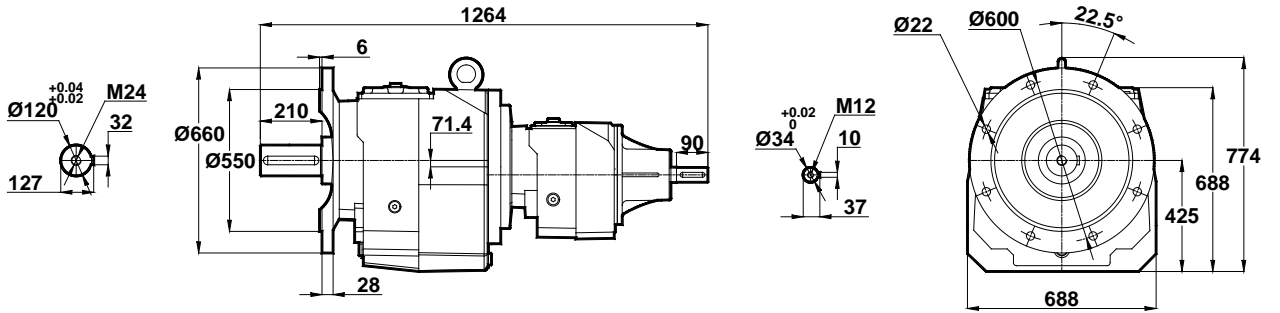



Ölçü Sayfaları Dimension Pages Abmessungsseiten



-Mil ucu çekirme deliği DIN 332 sayfa 2 / Tapped center hole to DIN 332, sheet 2 / Zentrierung mit gewinde DIN 332, Blatt 2

MTF002
MTF003

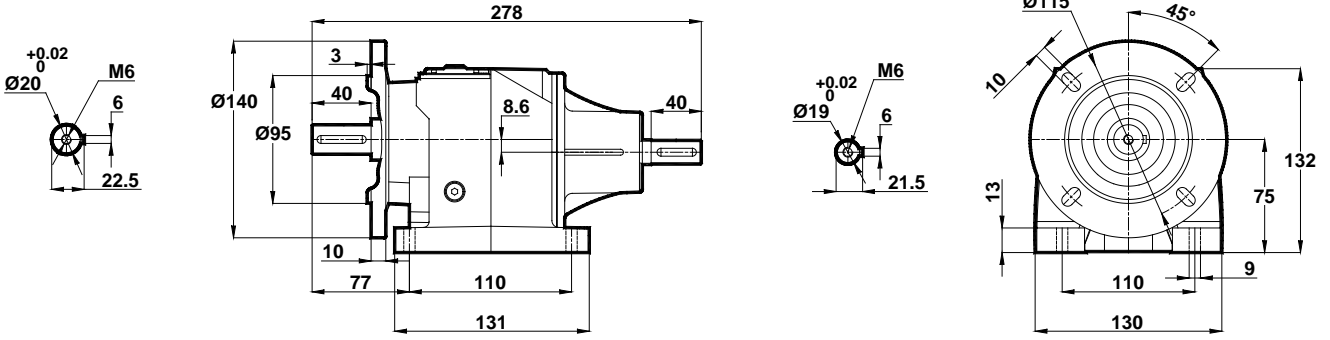

Opsiyonel Flanş Ölçüleri / Optional Flange Dimensions / Auswählbare Flanschabmessungen

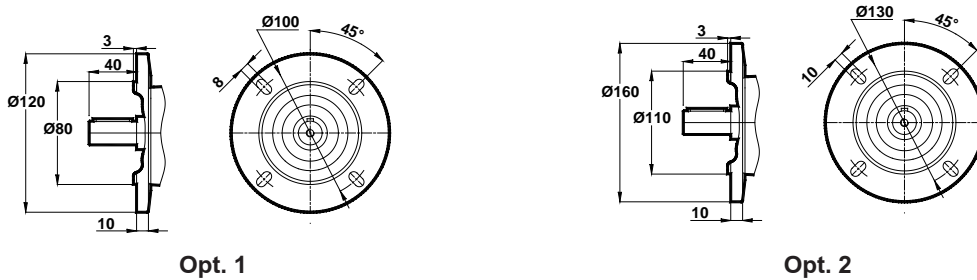



Ölçü Sayfaları Dimension Pages Abmessungsseiten



-Mil ucu çektirme deliği DIN 332 sayfa 2 / Tapped center hole to DIN 332, sheet 2 / Zentrierung mit gewinde DIN 332, Blatt 2

MTF102
MTF103

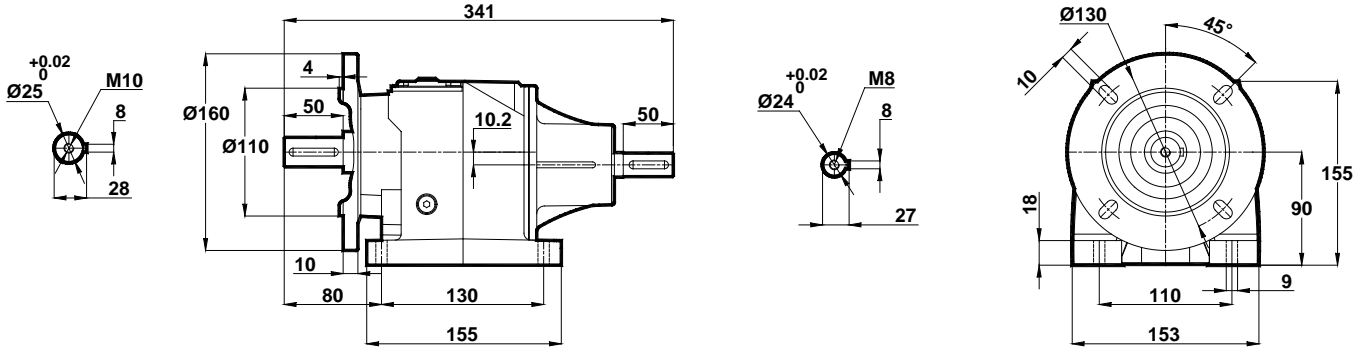

Opsiyonel Flanş Ölçüleri / Optional Flange Dimensions / Auswählbare Flanschabmessungen

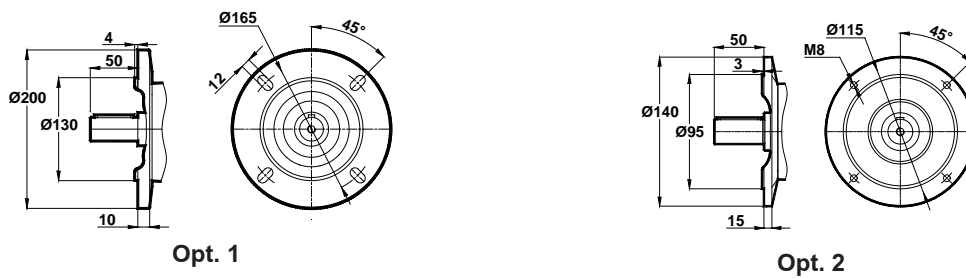



Ölçü Sayfaları Dimension Pages Abmessungenseiten



-Mil ucu çekirme deliği DIN 332 sayfa 2 / Tapped center hole to DIN 332, sheet 2 / Zentrierung mit gewinde DIN 332, Blatt 2

MTF172
MTF173

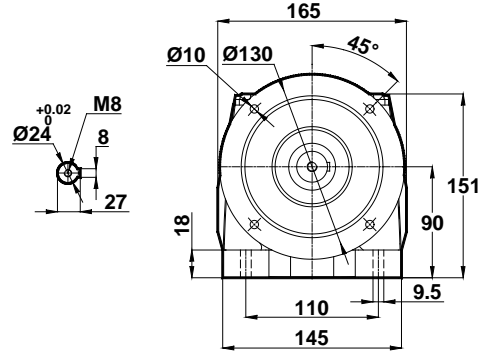
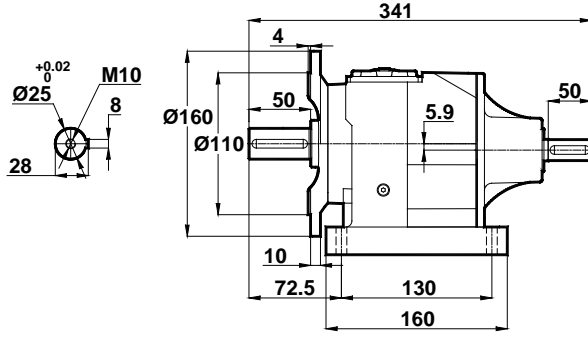

Opsiyonel Flanş Ölçüleri / Optional Flange Dimensions / Auswählbare Flanschabmessungen

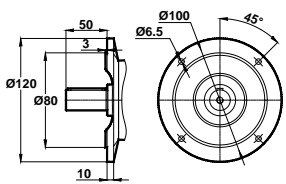

Opt. 1

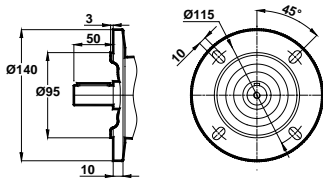

Opt. 2

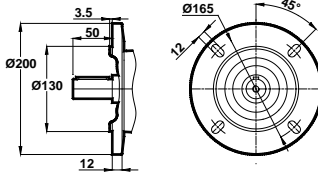

Opt. 3

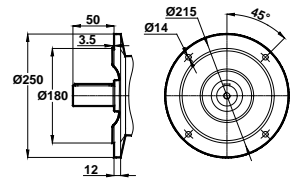

Opt. 4



Ölçü Sayfaları Dimension Pages Abmessungsseiten



-Mil ucu çektirme deliği DIN 332 sayfa 2 / Tapped center hole to DIN 332, sheet 2 / Zentrierung mit gewinde DIN 332, Blatt 2

MTF202
MTF203

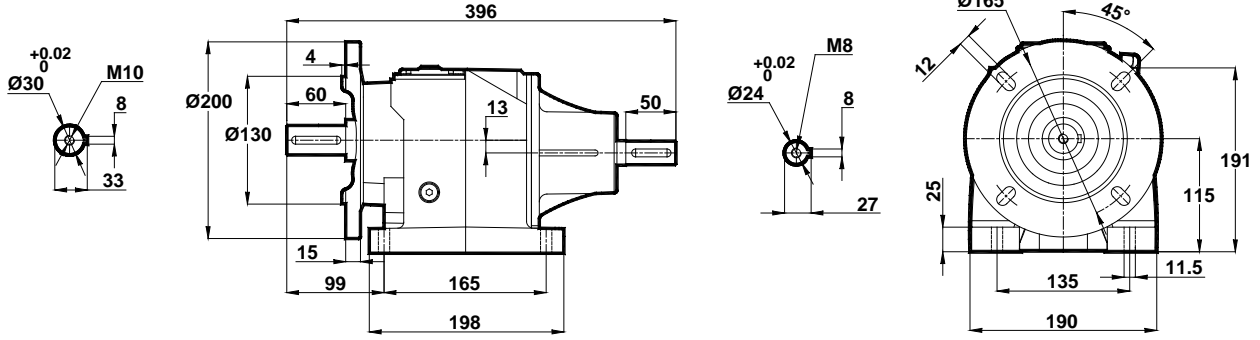

Opsiyonel Flanş Ölçüleri / Optional Flange Dimensions / Auswählbare Flanschabmessungen

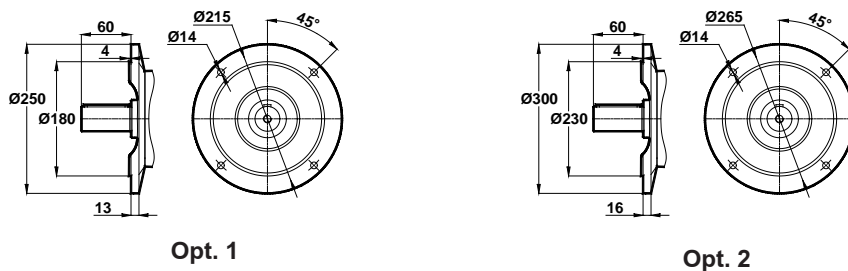



Ölçü Sayfaları Dimension Pages Abmessungenseiten



-Mil ucu çektirme deliği DIN 332 sayfa 2 / Tapped center hole to DIN 332, sheet 2 / Zentrierung mit gewinde DIN 332, Blatt 2

MTF272 MTF273

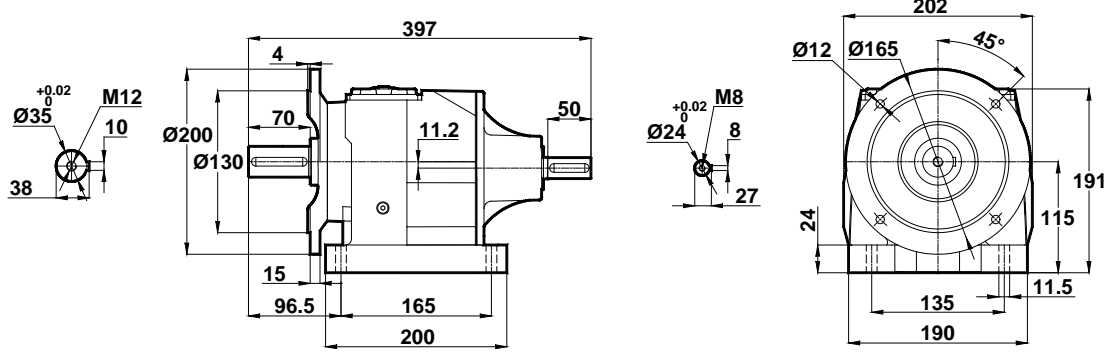

MTF275 MTF276

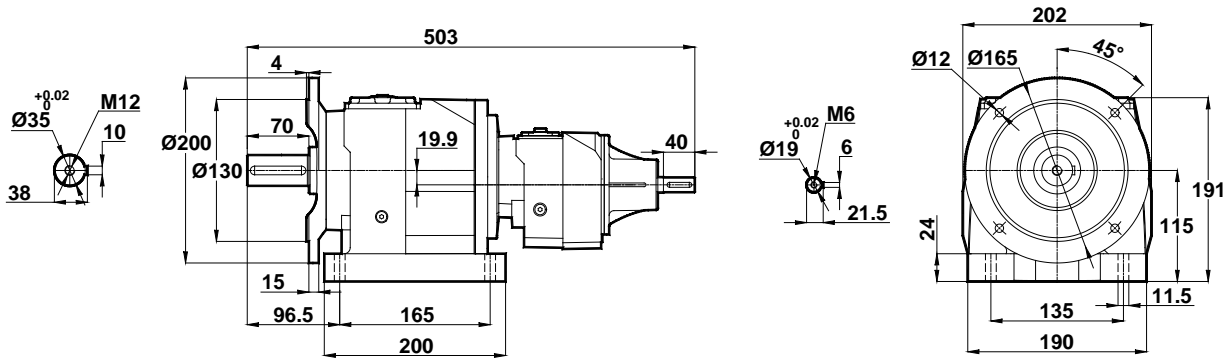

Opsiyonel Flanş Ölçüleri / Optional Flange Dimensions / Auswählbare Flanschabmessungen

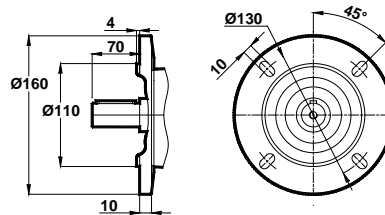

Opt. 1



Ölçü Sayfaları Dimension Pages Abmessungsseiten



-Mil ucu çektirme deliği DIN 332 sayfa 2 / Tapped center hole to DIN 332, sheet 2 / Zentrierung mit gewinde DIN 332, Blatt 2

MTF282 MTF283

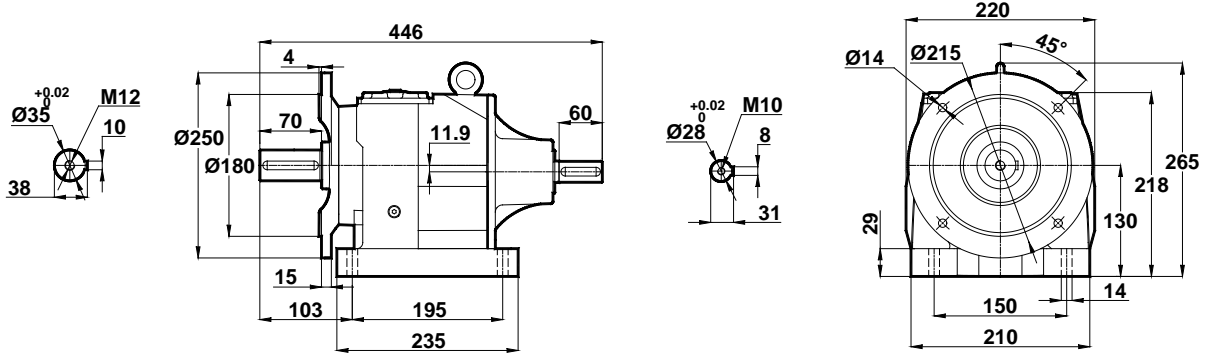

MTF284

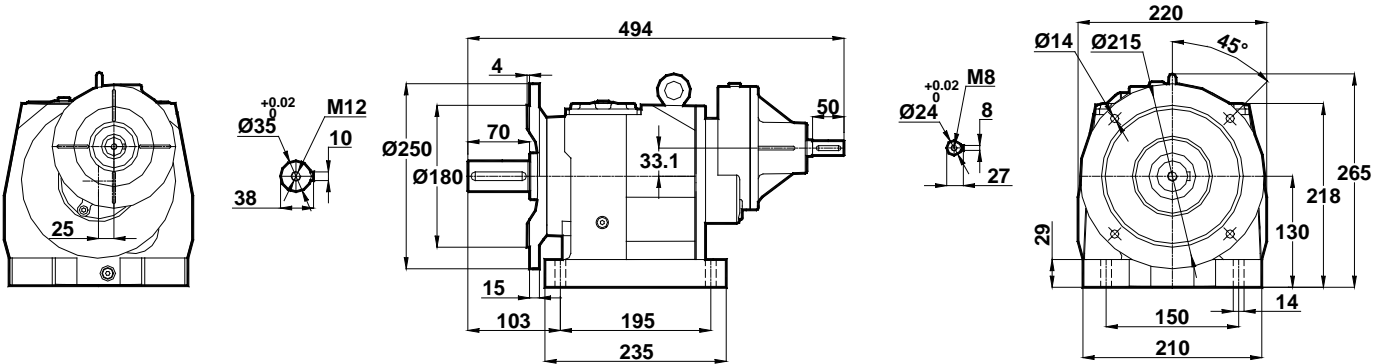

Opsiyonel Flanş Ölçüleri / Optional Flange Dimensions / Auswählbare Flanschabmessungen

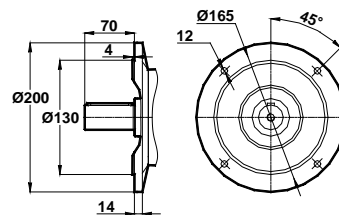

Opt. 1



Ölçü Sayfaları Dimension Pages Abmessungenseiten



-Mil ucu çekirme deliği DIN 332 sayfa 2 / Tapped center hole to DIN 332, sheet 2 / Zentrierung mit gewinde DIN 332, Blatt 2

MTF285
MTF286

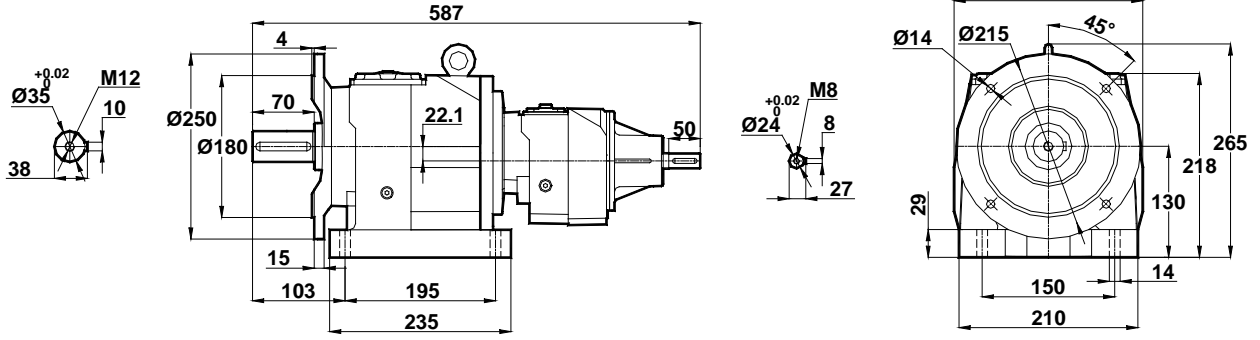

Opsiyonel Flanş Ölçüleri / Optional Flange Dimensions / Auswählbare Flanschabmessungen

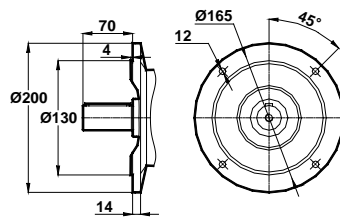

Opt. 1



Ölçü Sayfaları Dimension Pages Abmessungsseiten



-Mil ucu çektirme deliği DIN 332 sayfa 2 / Tapped center hole to DIN 332, sheet 2 / Zentrierung mit gewinde DIN 332, Blatt 2

MTF372 MTF373

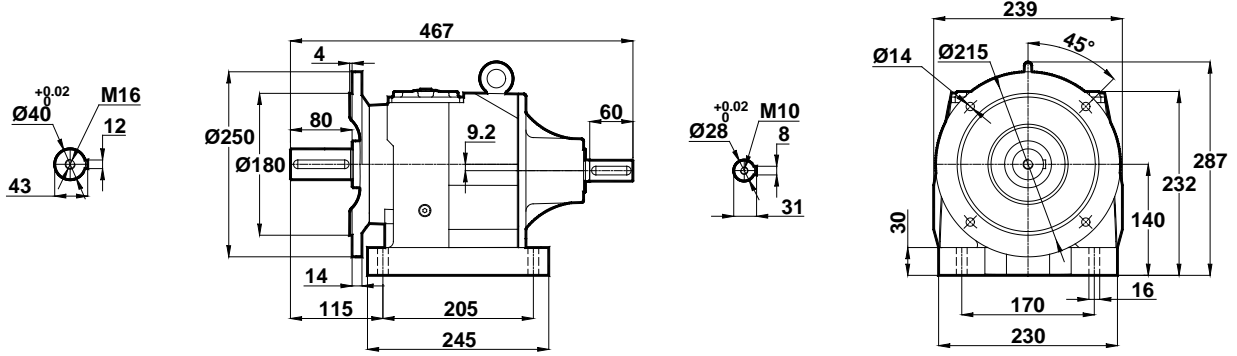

MTF374

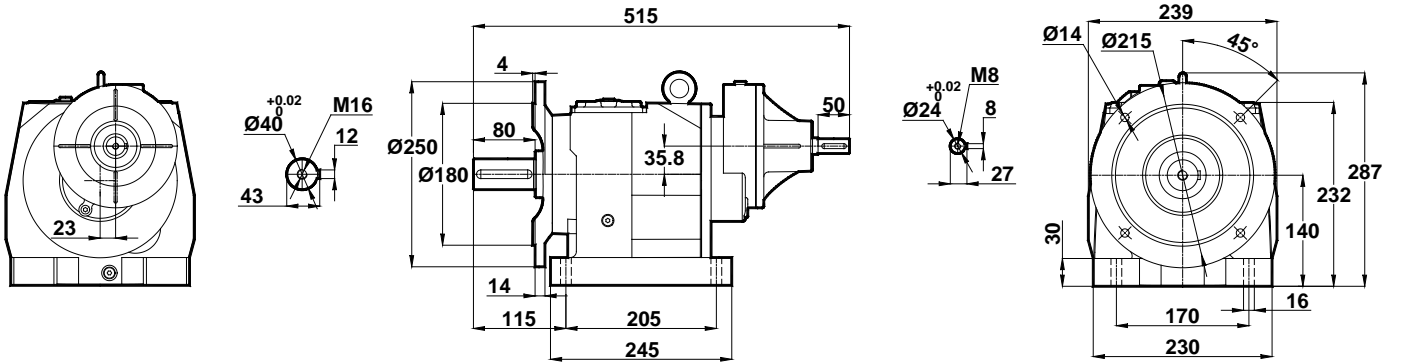

Opsiyonel Flanş Ölçüleri / Optional Flange Dimensions / Auswählbare Flanschabmessungen

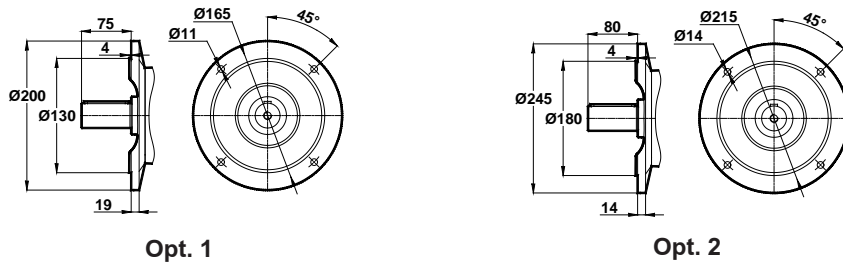



Ölçü Sayfaları Dimension Pages Abmessungsseiten



-Mil ucu çektirme deliği DIN 332 sayfa 2 / Tapped center hole to DIN 332, sheet 2 / Zentrierung mit gewinde DIN 332, Blatt 2

MTF375
MTF376

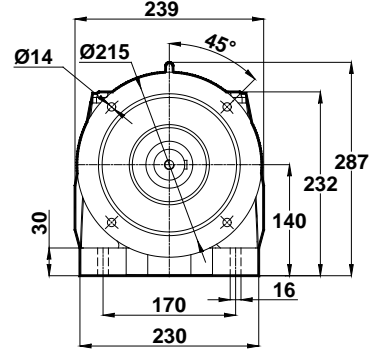
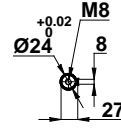
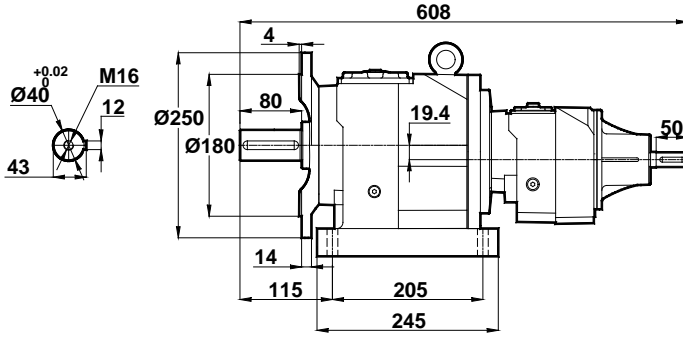

Opsiyonel Flanş Ölçüleri / Optional Flange Dimensions / Auswählbare Flanschabmessungen

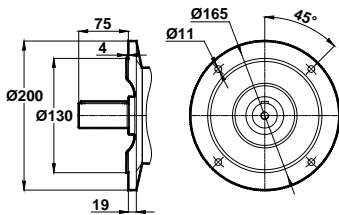

Opt. 1

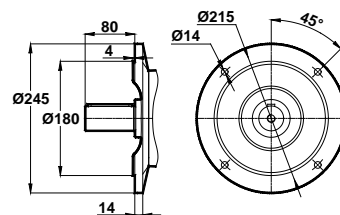

Opt. 2



Ölçü Sayfaları Dimension Pages Abmessungenseiten



-Mil ucu çektirme deliği DIN 332 sayfa 2 / Tapped center hole to DIN 332, sheet 2 / Zentrierung mit gewinde DIN 332, Blatt 2

MTF472
MTF473

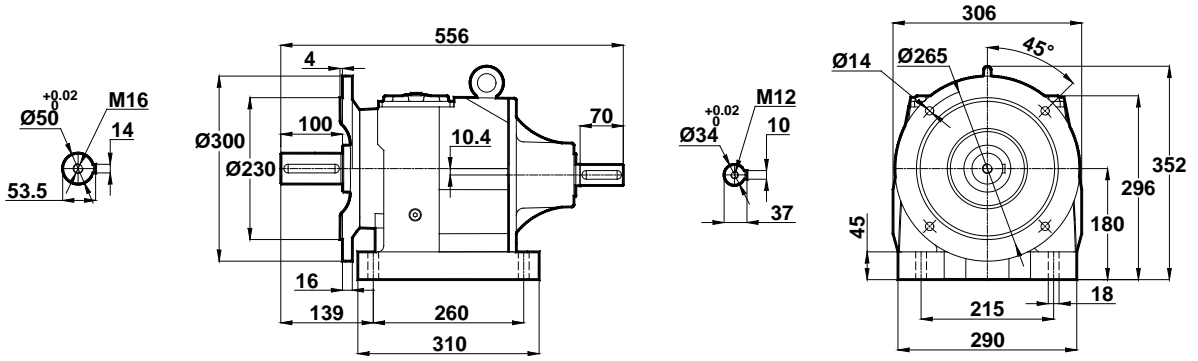

MTF474

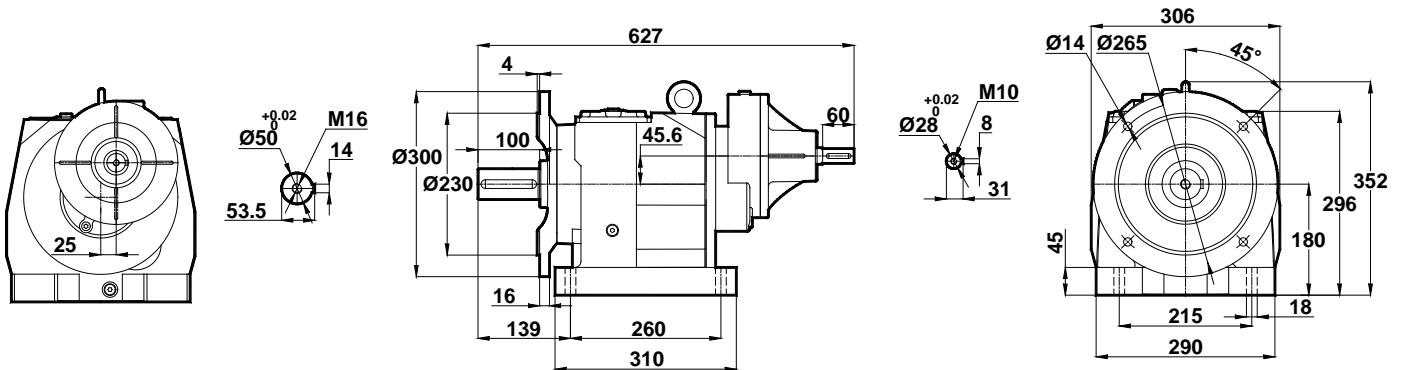

Opsiyonel Flanş Ölçüleri / Optional Flange Dimensions / Auswählbare Flanschabmessungen

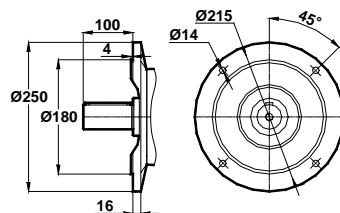

Opt. 1



Ölçü Sayfaları Dimension Pages Abmessungsseiten



-Mil ucu çekirme deliği DIN 332 sayfa 2 / Tapped center hole to DIN 332, sheet 2 / Zentrierung mit gewinde DIN 332, Blatt 2

MTF475
MTF476

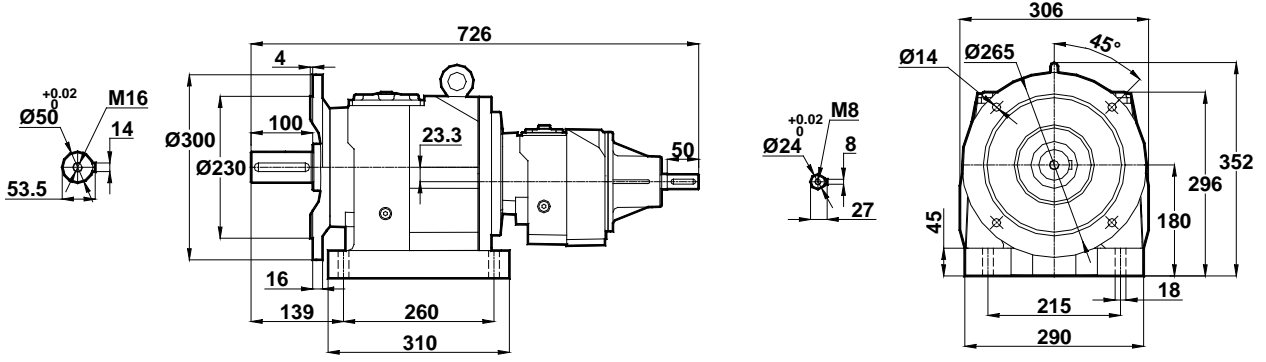

Opsiyonel Flanş Ölçüleri / Optional Flange Dimensions / Auswählbare Flanschabmessungen

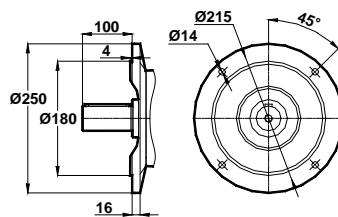

Opt. 1



Ölçü Sayfaları Dimension Pages Abmessungenseiten



-Mil ucu çekirme deliği DIN 332 sayfa 2 / Tapped center hole to DIN 332, sheet 2 / Zentrierung mit gewinde DIN 332, Blatt 2

NTB202
NTB203

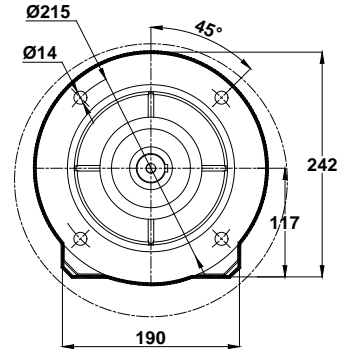
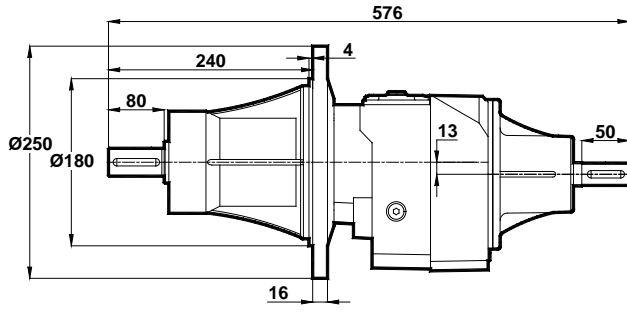
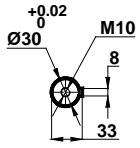



Ölçü Sayfaları Dimension Pages Abmessungsseiten



-Mil ucu çektirme deliği DIN 332 sayfa 2 / Tapped center hole to DIN 332, sheet 2 / Zentrierung mit gewinde DIN 332, Blatt 2

**NTB272
NTB273**

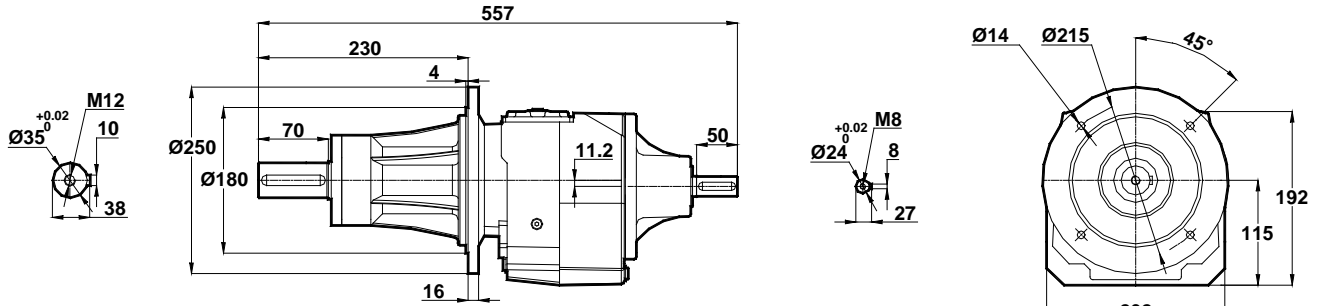

**NTB275
NTB276**

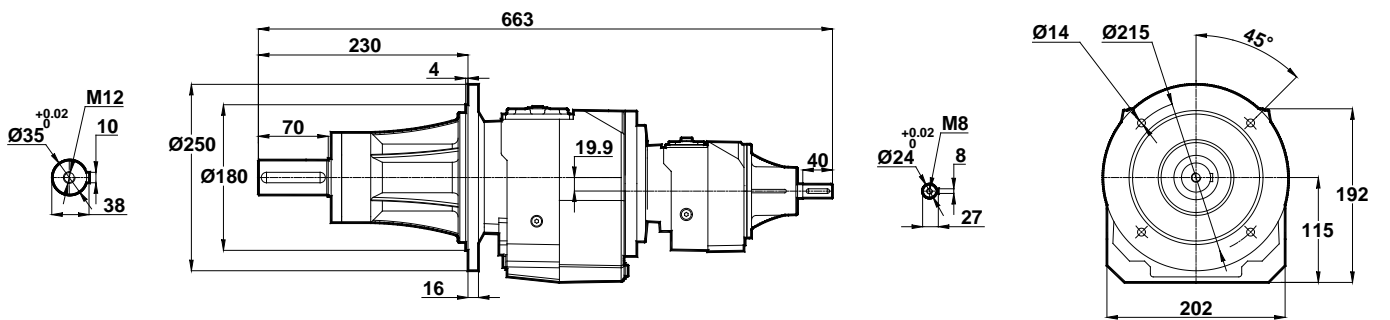



Ölçü Sayfaları

Dimension Pages

Abmessungsseiten



-Mil ucu çekirme deliği DIN 332 sayfa 2 / Tapped center hole to DIN 332, sheet 2 / Zentrierung mit gewinde DIN 332, Blatt 2

NTB282

NTB283

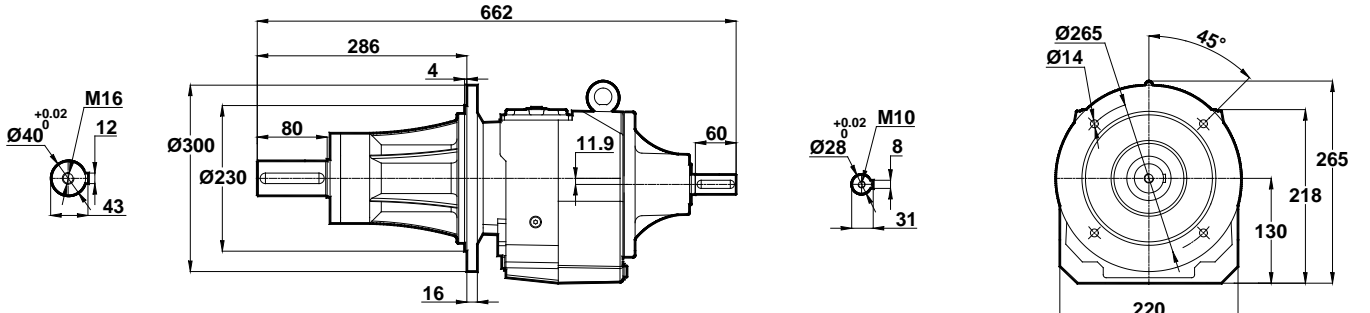

NTB284

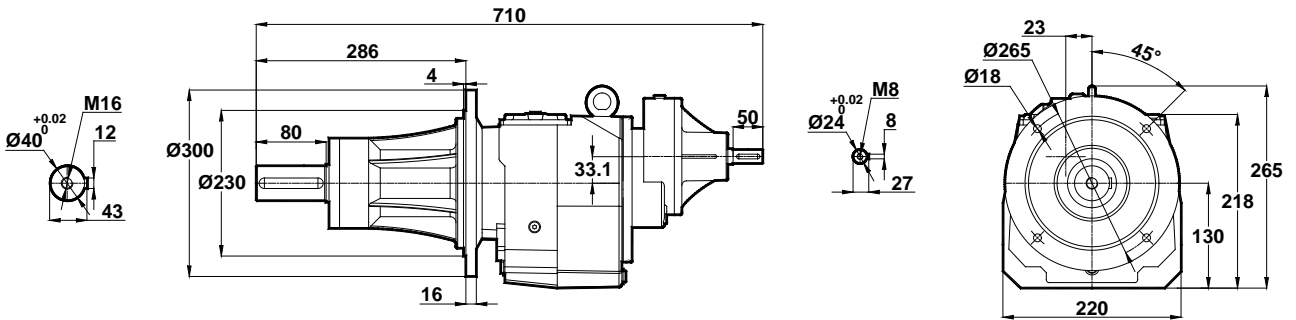



Ölçü Sayfaları Dimension Pages Abmessungenseiten



-Mil ucu çektirme deliği DIN 332 sayfa 2 / Tapped center hole to DIN 332, sheet 2 / Zentrierung mit gewinde DIN 332, Blatt 2

NTB285
NTB286

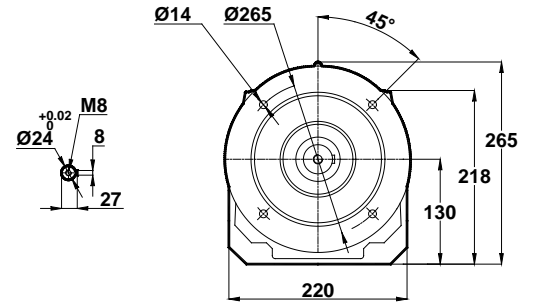
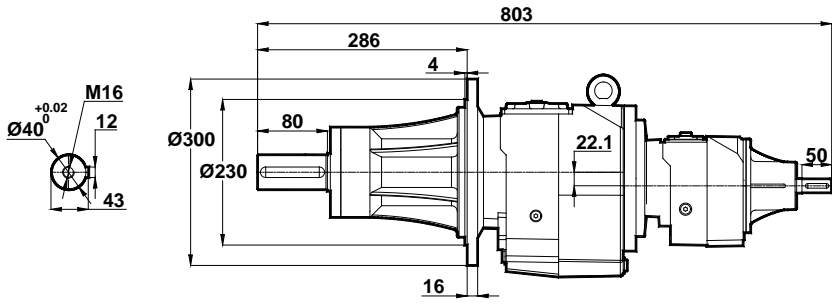



Ölçü Sayfaları

Dimension Pages

Abmessungsseiten



-Mil ucu çekirme deliği DIN 332 sayfa 2 / Tapped center hole to DIN 332, sheet 2 / Zentrierung mit gewinde DIN 332, Blatt 2

NTB372

NTB373

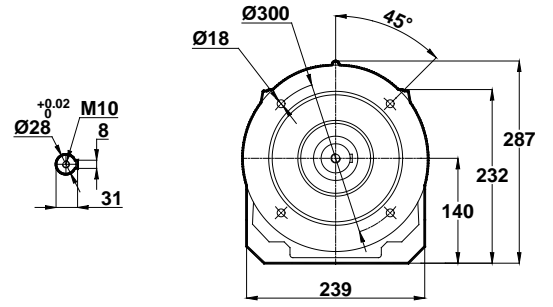
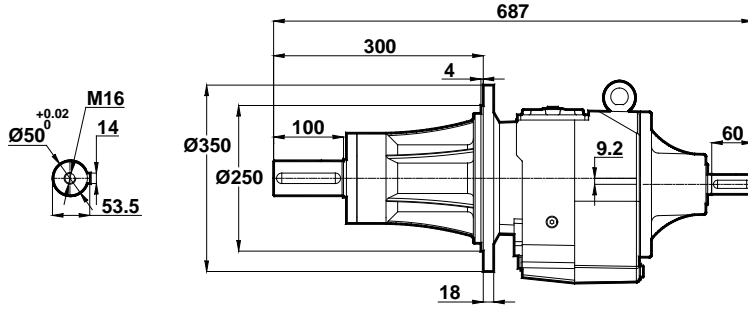

NTB374

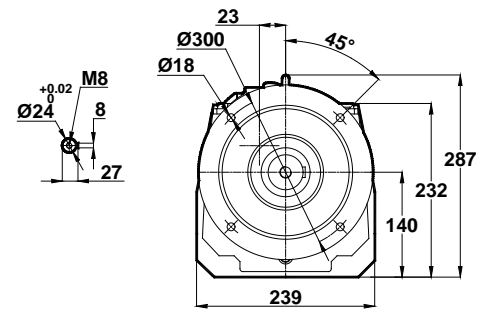
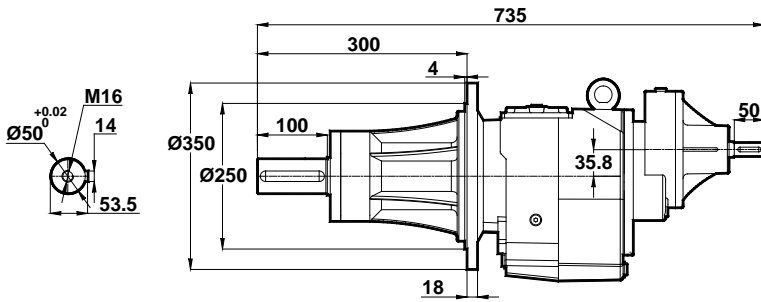



Ölçü Sayfaları Dimension Pages Abmessungsseiten



-Mil ucu çektirme deliği DIN 332 sayfa 2 / Tapped center hole to DIN 332, sheet 2 / Zentrierung mit gewinde DIN 332, Blatt 2

NTB375
NTB376

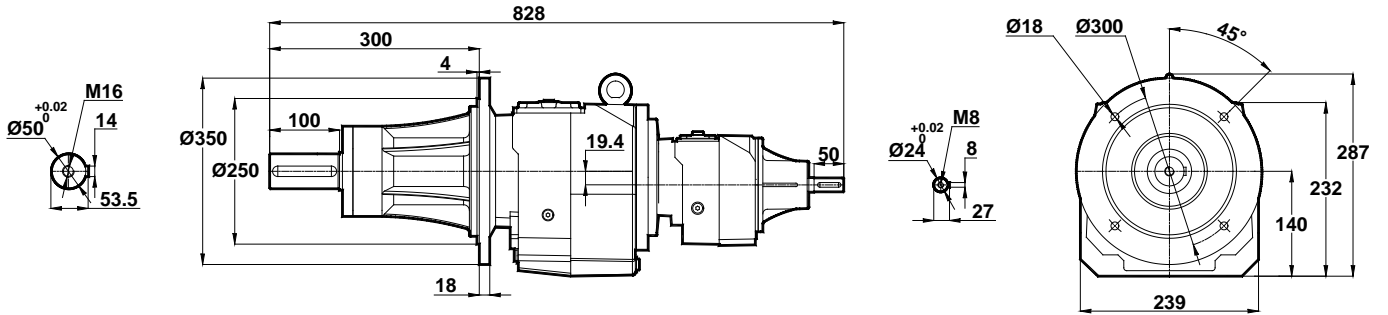



Ölçü Sayfaları Dimension Pages Abmessungsseiten



-Mil ucu çekirme deliği DIN 332 sayfa 2 / Tapped center hole to DIN 332, sheet 2 / Zentrierung mit gewinde DIN 332, Blatt 2

NTB472 NTB473

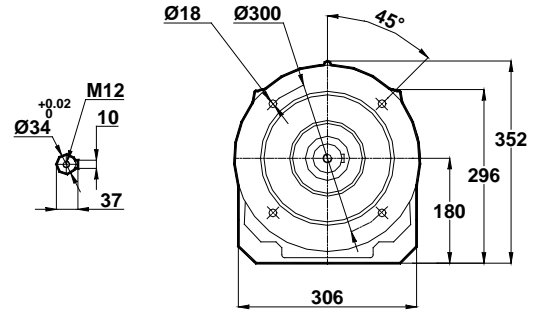
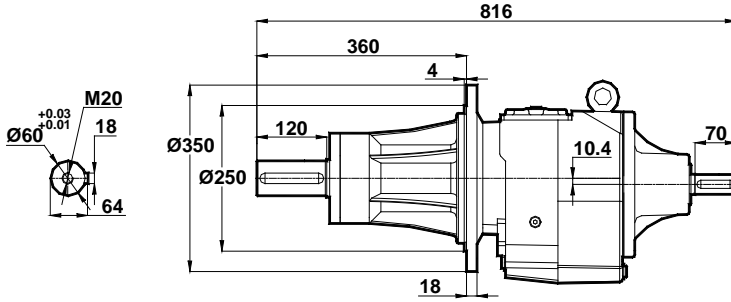

NTB474

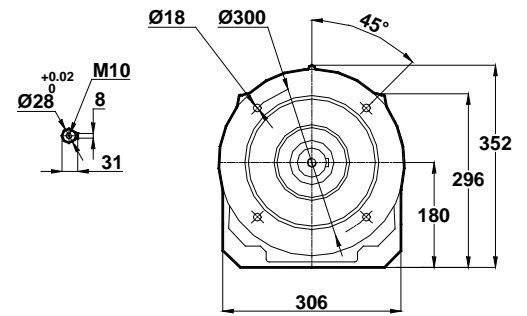
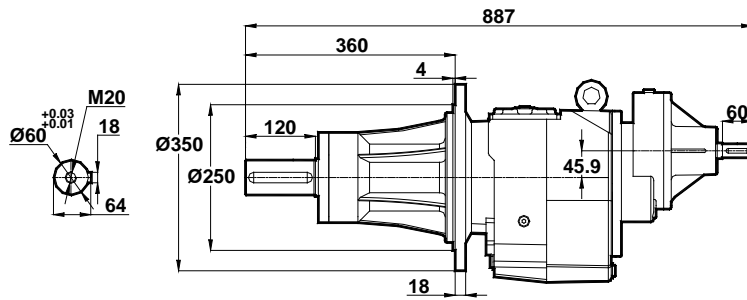



Ölçü Sayfaları Dimension Pages Abmessungsseiten



-Mil ucu çektirme deliği DIN 332 sayfa 2 / Tapped center hole to DIN 332, sheet 2 / Zentrierung mit gewinde DIN 332, Blatt 2

NTB475
NTB476

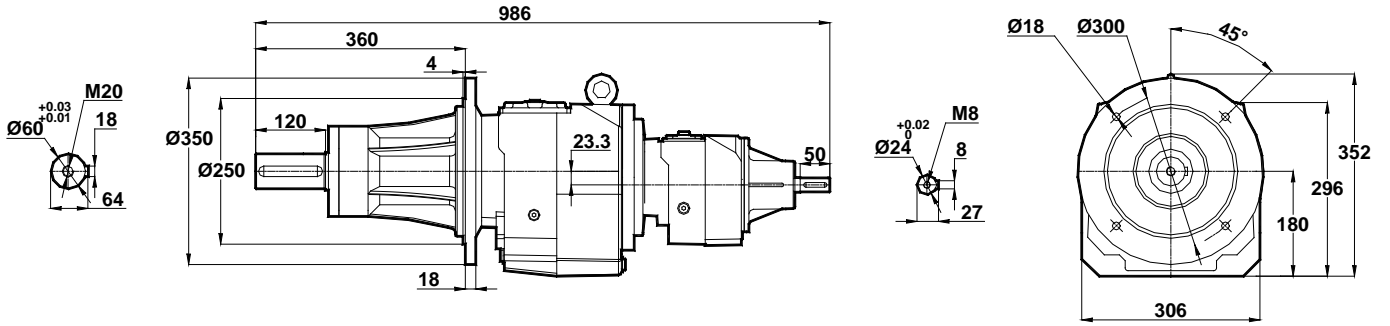



Ölçü Sayfaları Dimension Pages Abmessungenseiten



-Mil ucu çekirme deliği DIN 332 sayfa 2 / Tapped center hole to DIN 332, sheet 2 / Zentrierung mit gewinde DIN 332, Blatt 2

NTB572 NTB573

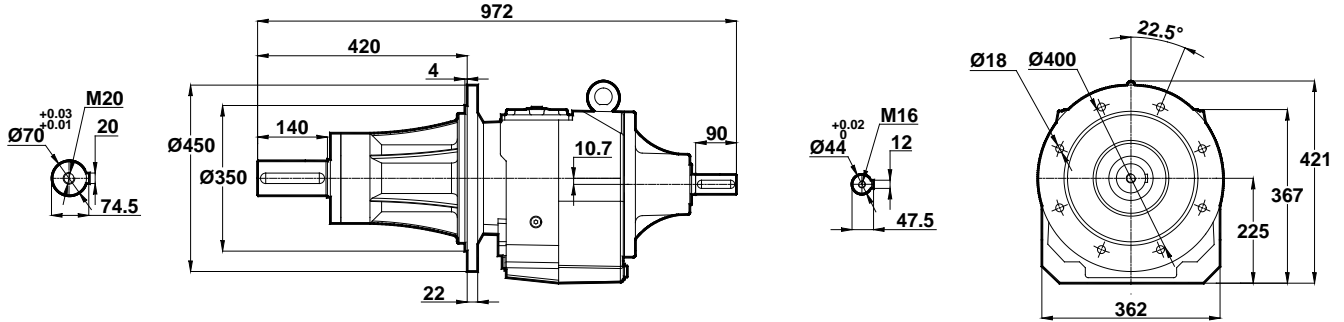

NTB574

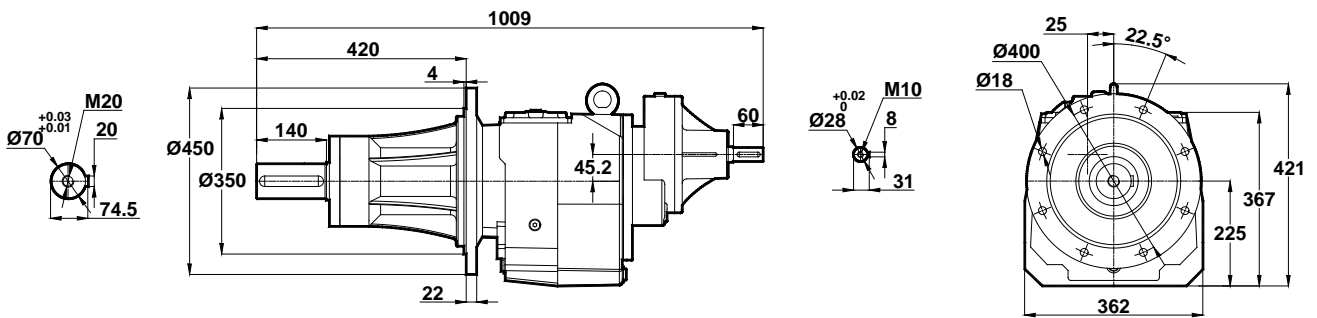



Ölçü Sayfaları Dimension Pages Abmessungsseiten



-Mil ucu çektirme deliği DIN 332 sayfa 2 / Tapped center hole to DIN 332, sheet 2 / Zentrierung mit gewinde DIN 332, Blatt 2

NTB575
NTB576

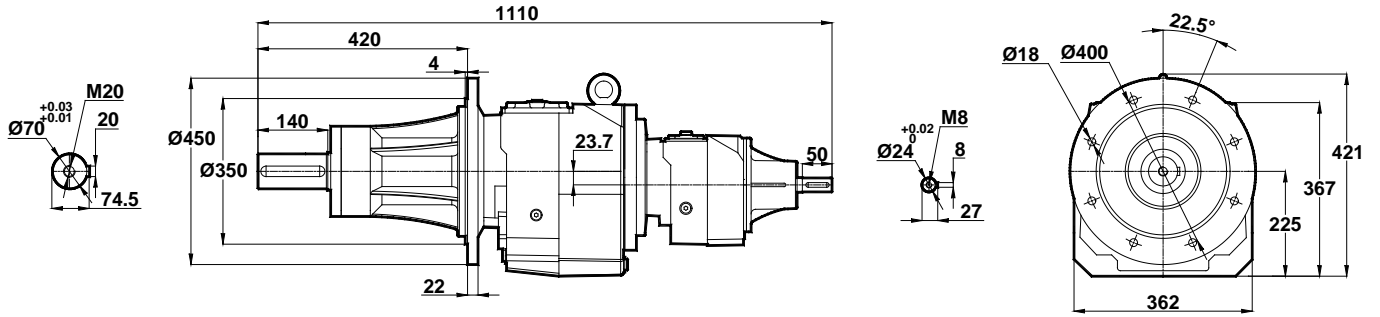



Ölçü Sayfaları Dimension Pages Abmessungsseiten



-Mil ucu çekirme deliği DIN 332 sayfa 2 / Tapped center hole to DIN 332, sheet 2 / Zentrierung mit gewinde DIN 332, Blatt 2

NTB672 NTB673

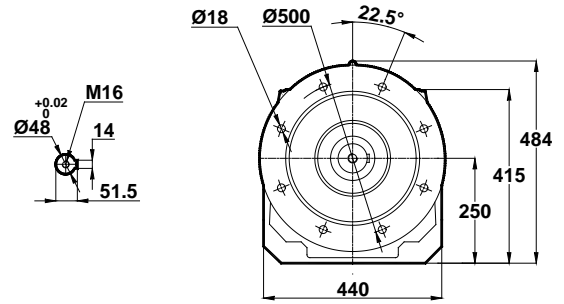
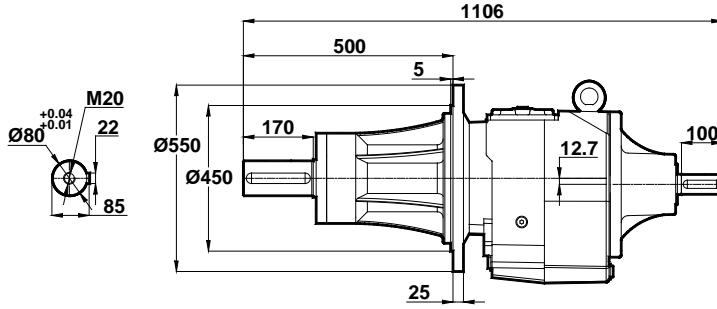

NTB674

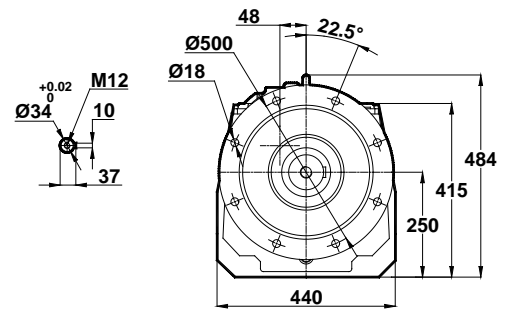
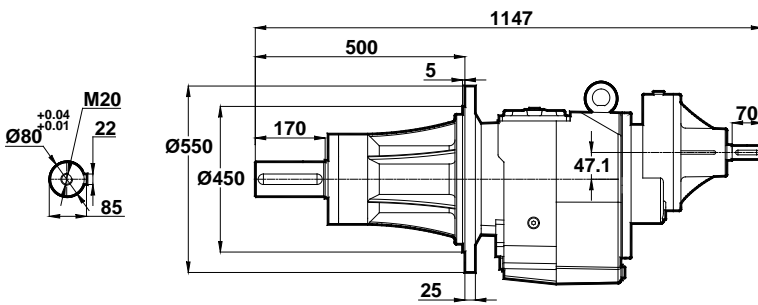



Ölçü Sayfaları Dimension Pages Abmessungsseiten



-Mil ucu çektirme deliği DIN 332 sayfa 2 / Tapped center hole to DIN 332, sheet 2 / Zentrierung mit gewinde DIN 332, Blatt 2

NTB675
NTB676

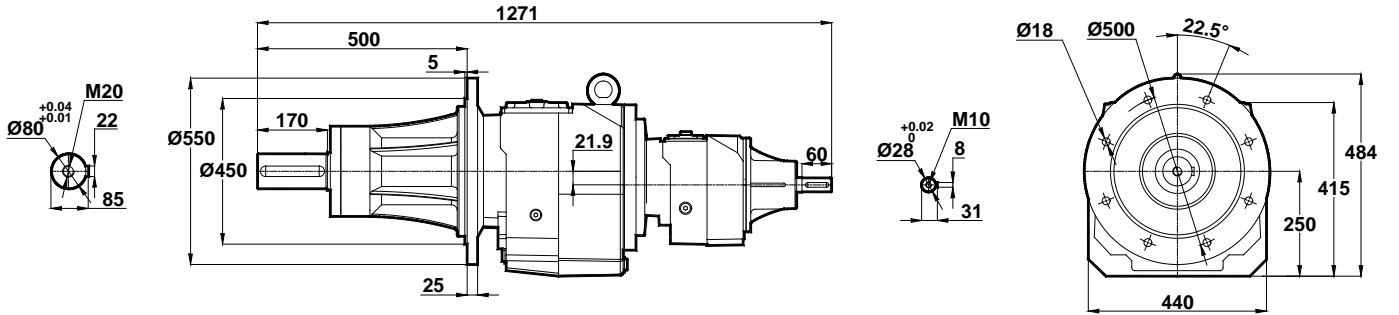



Ölçü Sayfaları Dimension Pages Abmessungsseiten



-Mil ucu çekirme deliği DIN 332 sayfa 2 / Tapped center hole to DIN 332, sheet 2 / Zentrierung mit gewinde DIN 332, Blatt 2

NTB772 NTB773

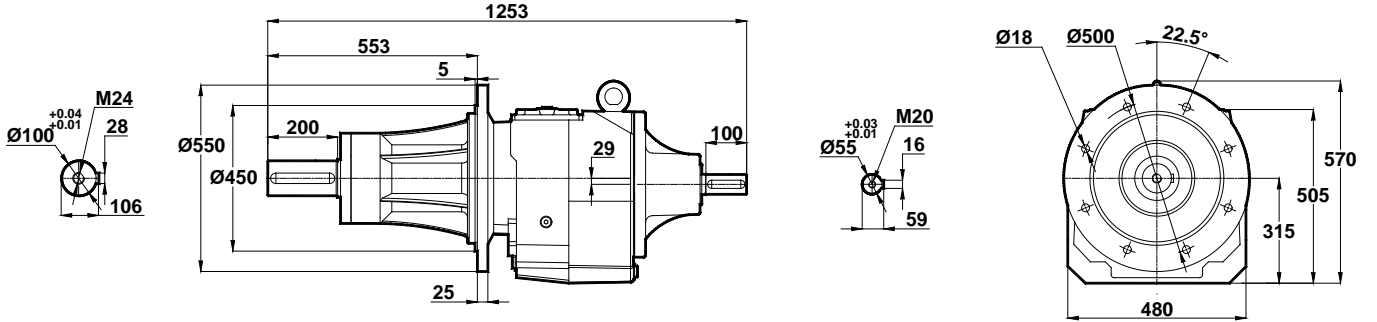

NTB774

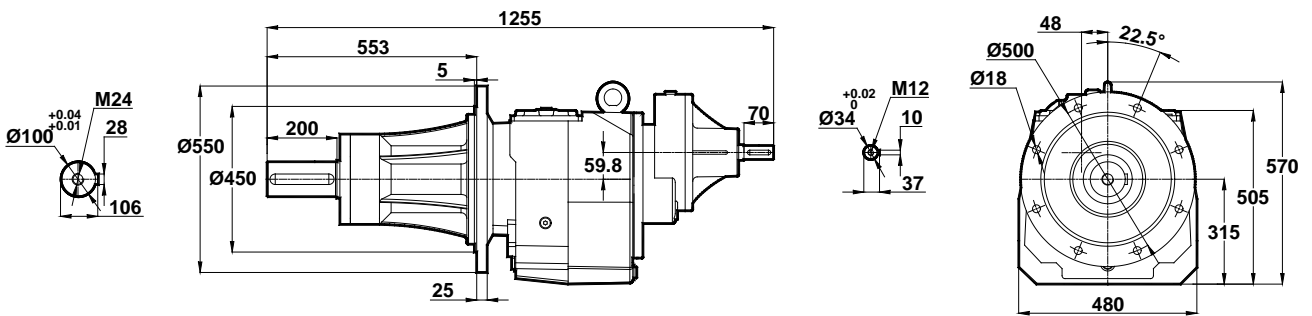



Ölçü Sayfaları Dimension Pages Abmessungsseiten



-Mil ucu çektirme deliği DIN 332 sayfa 2 / Tapped center hole to DIN 332, sheet 2 / Zentrierung mit gewinde DIN 332, Blatt 2

NTB775
NTB776

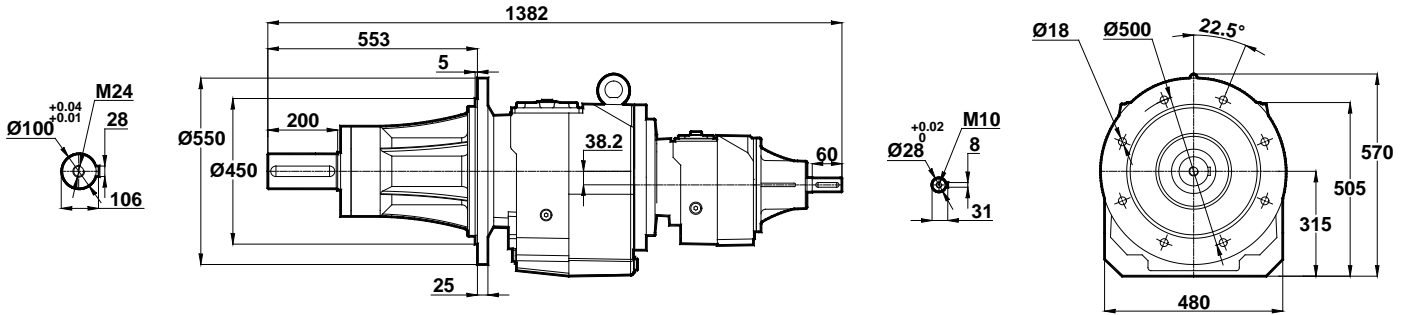



Ölçü Sayfaları Dimension Pages Abmessungsseiten



-Mil ucu çektirme deliği DIN 332 sayfa 2 / Tapped center hole to DIN 332, sheet 2 / Zentrierung mit gewinde DIN 332, Blatt 2

NTB872 NTB873

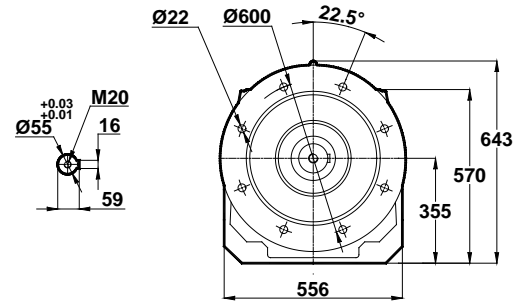
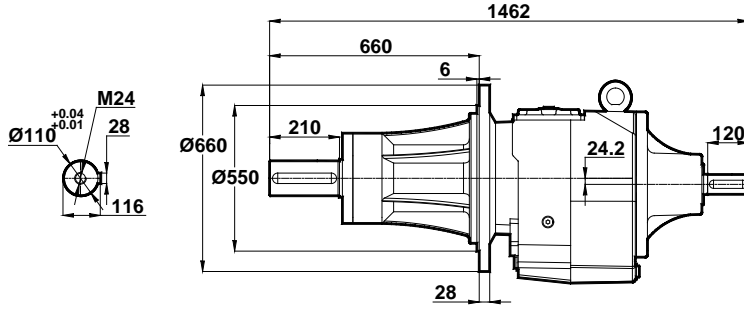

NTB874

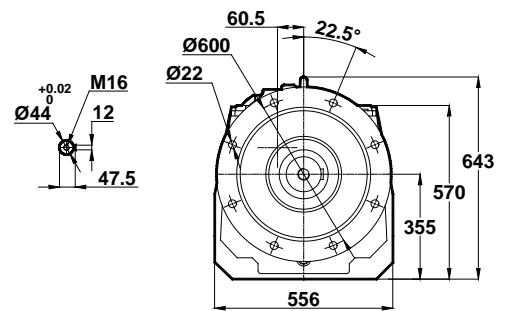
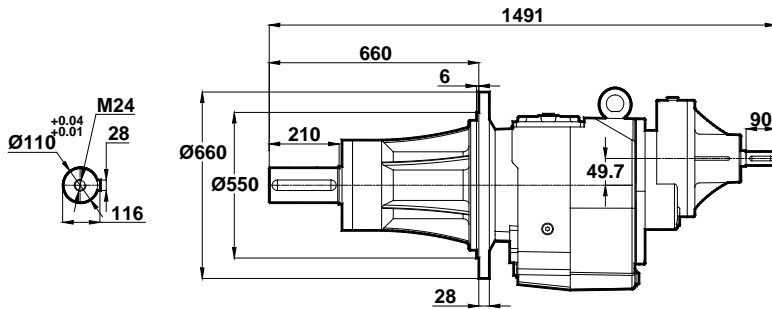



Ölçü Sayfaları Dimension Pages Abmessungsseiten



-Mil ucu çektirme deliği DIN 332 sayfa 2 / Tapped center hole to DIN 332, sheet 2 / Zentrierung mit gewinde DIN 332, Blatt 2

NTB875
NTB876

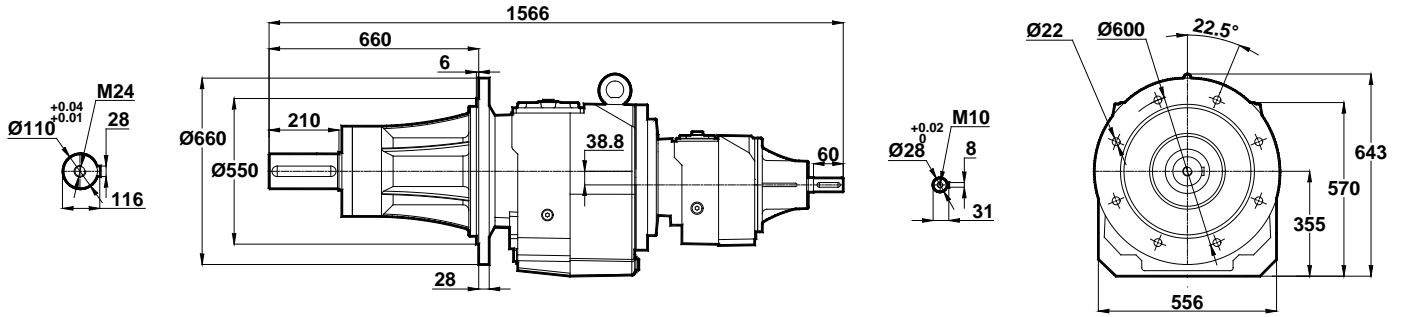



Ölçü Sayfaları Dimension Pages Abmessungsseiten



-Mil ucu çektirme deliği DIN 332 sayfa 2 / Tapped center hole to DIN 332, sheet 2 / Zentrierung mit gewinde DIN 332, Blatt 2

NTB972 NTB973

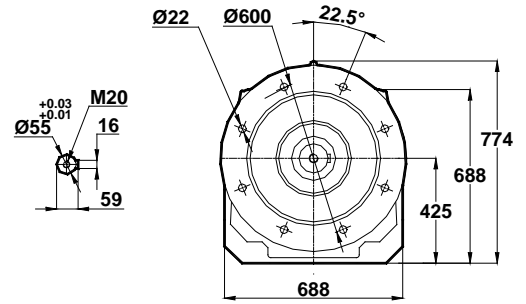
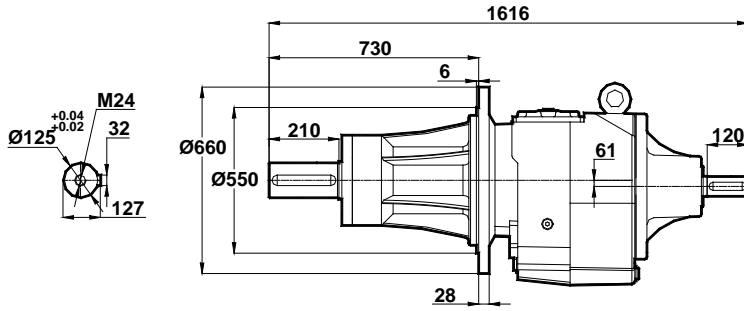

NTB974

